



INSTALL GUIDE

2016 AUDI S4 PTS WITH KEYPORT AUTOMATIC



DOCUMENT NUMBER

A558F12

REVISION DATE

20211223_151400

FIRMWARE

RSA-AUD2

HARDWARE

CMVWXA0

ACCESSORIES

ATTENTION: TO COMPLETE THIS INSTALLATION SOME ACCESSORIES MAY BE REQUIRED. VISIT OUR WEBSITE TO SEE ALL THE REQUIRED ACCESSORIES FOR YOUR VEHICLE.

TERMS OF USE

Automotive Data Solutions Inc. ("ADS") products are strictly intended for installation by Certified Technicians who are employed by a registered business specialized in the installation of automotive aftermarket electronics products. Prior to beginning installation of an ADS product in a vehicle, it is the Certified Technician's responsibility to review the most current Product Guide, Install Guide and vehicle-specific notes available in Weblink®. ADS is not responsible for any damages whatsoever, including but not limited to any consequential damages, incidental damages, damages for loss of time, loss of earnings, loss of profit, commercial loss, loss of economic opportunity and the like that may or may not have resulted from the use, misuse, improper installation or operation of its products. ADS reserves itself the right to suspend any Weblink® account without notice and decline to offer technical support to non-Certified Technicians, noncompliant Certified Technicians or end users.

REMOTE START	Supported
Data Immobilizer Bypass (no key required)	
Key Required for Immobilizer Bypass	
Takeover Available	
No Takeover Available (shutdown on unlock or door open)	
3x Lock Start from OEM Remotes	
Data / MUX Parking Light Control - Constant	
Data / MUX / Hazard Parking Light Control - Flashing	
Tach Monitoring	
Hood Status	
Brake Status	
E-Brake Status	
Glow Plug Status	
RAP Shutdown	

KEYLESS ENTRY	Supported
OEM Remotes Functional during RS	
OEM RFID Entry Sensors Functional during RS	
Door Lock	
Door Unlock	
Driver Door Priority Unlock	
Trunk/Hatch Release	
Power Liftgate	
Power Sliding Door (L)	
Power Sliding Door (R)	

SECURITY SYSTEM	Supported
Arm OEM Alarm	
Disarm OEM Alarm	
Aftermarket Alarm Control from OEM Remotes	
Aftermarket Alarm Control from OEM RFID Entry Sensors	
Door Status	
Trunk/Hatch Status	

COMFORT	Supported
Rear Defrost Activation	
Heated Mirror Activation	
Heated Seat Activation	
Cooled Seat Activation	
Heated Steering Wheel Activation	

MODULE CONNECTORS

CONNECTOR PINOUT

MODULE

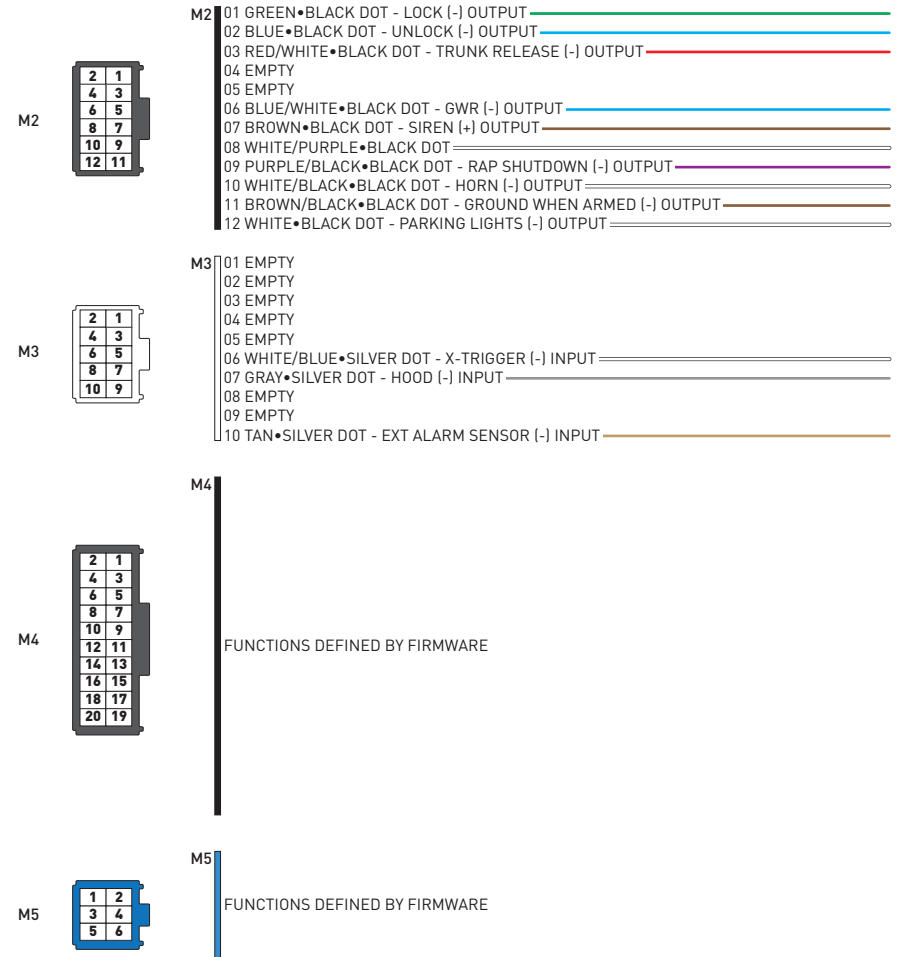
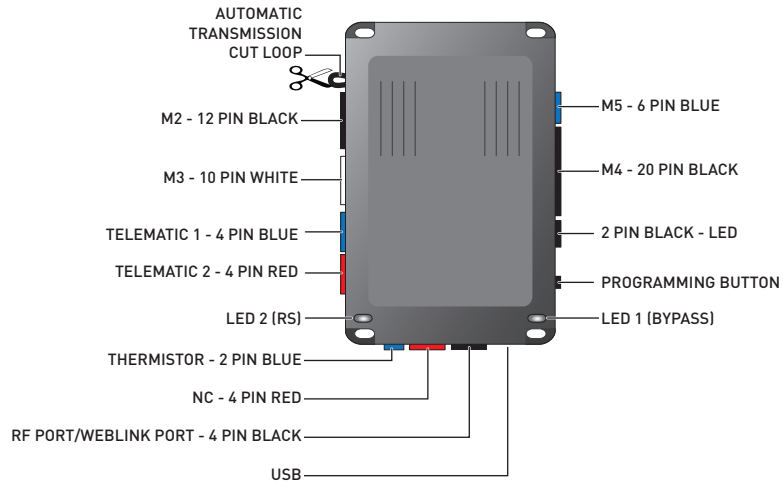

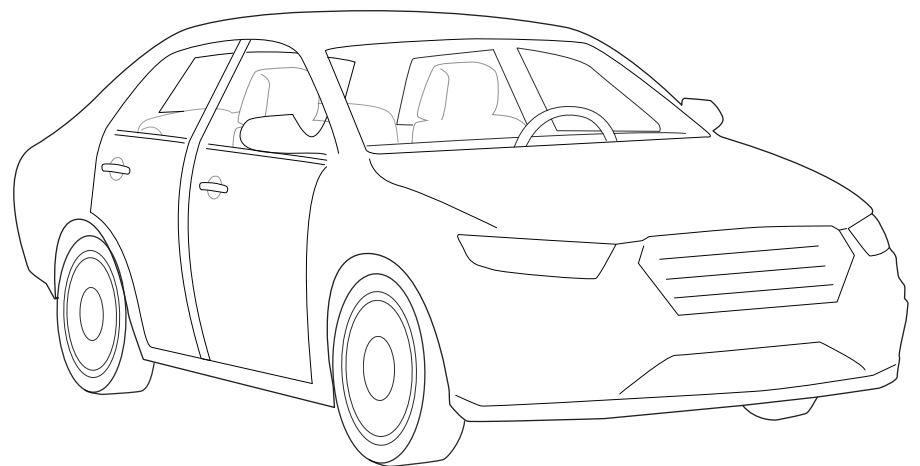
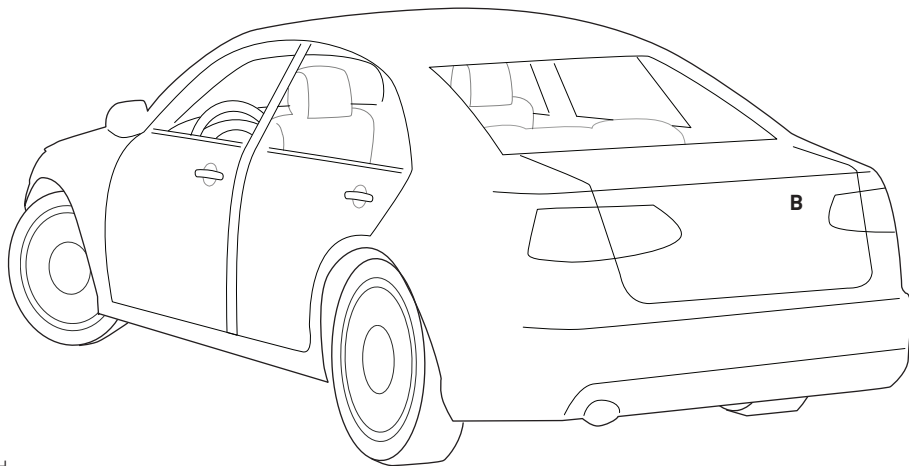
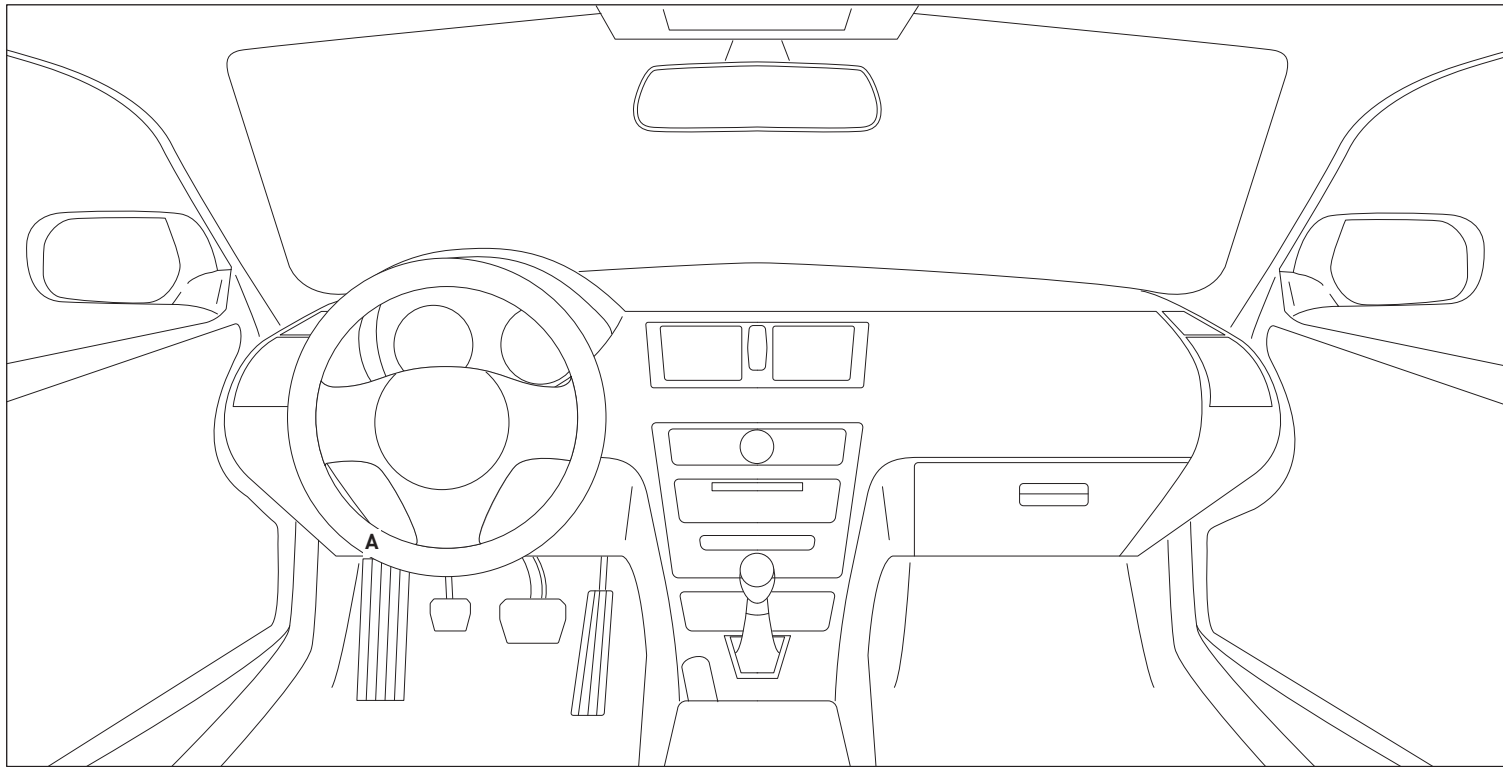

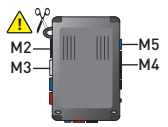

- CUT LOOP FOR AUTOMATIC TRANSMISSION ONLY
- USE OPTIONAL AUD-RF HARNESS TO EXTEND THE AFTERMARKET ANTENNA PLACEMENT IF NEEDED.

- M2**
- 01 GREEN•BLACK DOT
 - 02 BLUE•BLACK DOT
 - 03 RED/WHITE•BLACK DOT
 - 04 EMPTY
 - 05 EMPTY
 - 06 BLUE/WHITE•BLACK DOT
 - 07 BROWN•BLACK DOT
 - 08 WHITE/PURPLE•BLACK DOT
 - 09 PURPLE/BLACK•BLACK DOT
 - 10 WHITE/BLACK•BLACK DOT
 - 11 BROWN/BLACK•BLACK DOT
 - 12 WHITE•BLACK DOT

- M3**
- 01 EMPTY
 - 02 EMPTY
 - 03 EMPTY
 - 04 EMPTY
 - 05 EMPTY
 - 06 WHITE/BLUE•SILVER DOT
 - 07 GRAY•SILVER DOT
 - 08 EMPTY
 - 09 EMPTY
 - 10 TAN•SILVER DOT

- M4**
- 01
 - 02
 - 03
 - 04
 - 05
 - 06
 - 07
 - 08
 - 09
 - 10
 - 11
 - 12
 - 13
 - 14
 - 15
 - 16
 - 17
 - 18
 - 19
 - 20

- M5**
- 01
 - 02
 - 03
 - 04
 - 05
 - 06

PRE-INSTALLATION PROCEDURE

- 1- CONNECT ADS-AUD2-OB2 HARNESS AS SHOWN.
- 2- SET IGNITION TO ON POSITION.
- 3- LOOK IF MODULE LED FLASHED GREEN OR RED.
- 4- DISCONNECT ADS-AUD2-OB2 HARNESS AND TURN IGNITION TO OFF.

IF MODULE LED FLASHES GREEN:

DO NOT USE THE KEY BOX.

FOLLOW TYPE-1 (KLON) PROGRAMMING PROCEDURE.

IF MODULE LED FLASHES RED:

→ **REMOVE BATTERY FROM KEYFOB.**

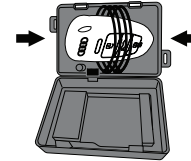

PUT KEYFOB IN KEY BOX (AS SHOWN).

CONNECT T-HARNESS TO KEY BOX BLACK CONNECTOR (SEE NEXT PAGE).

CONNECT T-HARNESS TO KEY BOX BLACK CONNECTOR (SEE NEXT PAGE).

FOLLOW TYPE-2 PROGRAMMING PROCEDURE.

IMPORTANT: KEYFOB WILL REMAIN PERMANENTLY IN THE VEHICLE.

ADS-AUD2-OB2

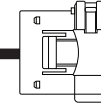

— OBDII, ABOVE DRIVER KICK PANEL (A) —

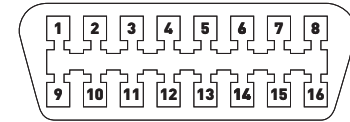

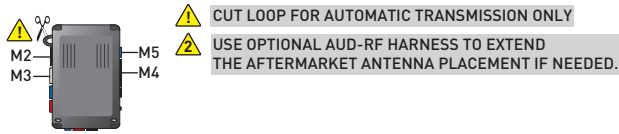

- M2**
- 01 GREEN•BLACK DOT- PTS 1 (-) OUTPUT
 - 02 BLUE•BLACK DOT- PTS 2 (-) OUTPUT
 - 03 RED/WHITE•BLACK DOT
 - 04 EMPTY
 - 05 EMPTY
 - 06 BLUE/WHITE•BLACK DOT
 - 07 BROWN•BLACK DOT
 - 08 WHITE/PURPLE•BLACK DOT
 - 09 PURPLE/BLACK•BLACK DOT
 - 10 WHITE/BLACK•BLACK DOT
 - 11 BROWN/BLACK•BLACK DOT
 - 12 WHITE•BLACK DOT

- M3**
- 01 EMPTY
 - 02 EMPTY
 - 03 EMPTY
 - 04 EMPTY
 - 05 EMPTY
 - 06 WHITE/BLUE•SILVER DOT
 - 07 GRAY•SILVER DOT - HOOD (-) INPUT
 - 08 EMPTY
 - 09 EMPTY
 - 10 TAN•SILVER DOT

- M4**
- 01
 - 02
 - 03
 - 04
 - 05
 - 06
 - 07
 - 08
 - 09
 - 10
 - 11
 - 12
 - 13
 - 14
 - 15
 - 16
 - 17
 - 18
 - 19
 - 20

- M5**
- 01
 - 02
 - 03
 - 04
 - 05
 - 06

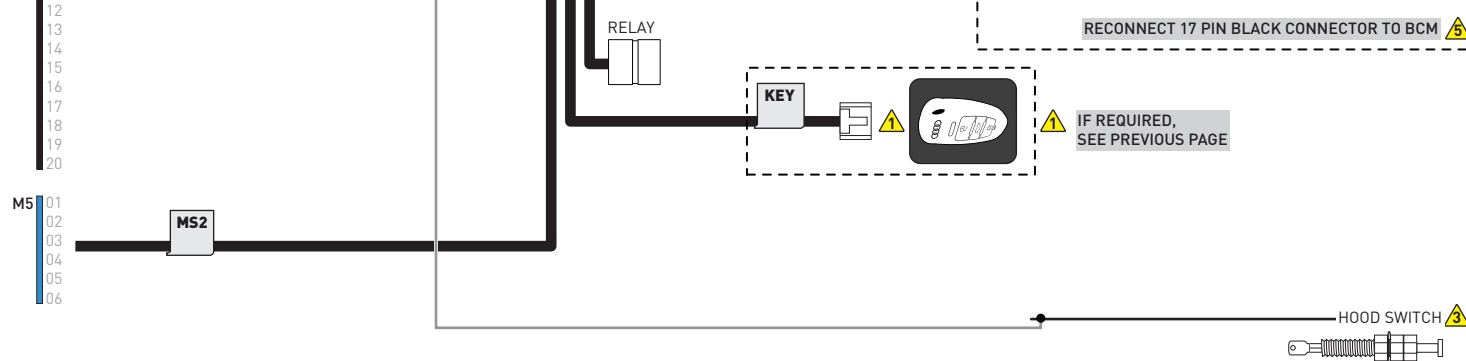
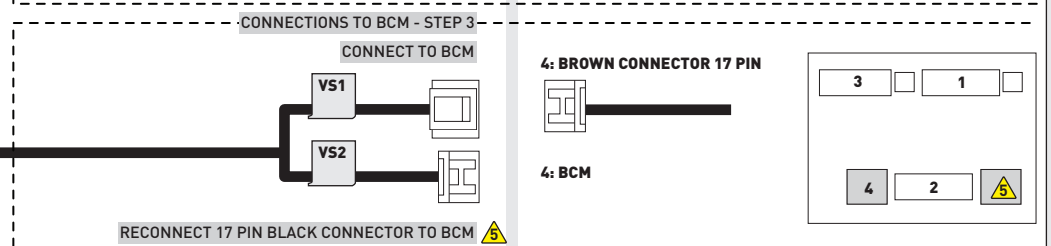
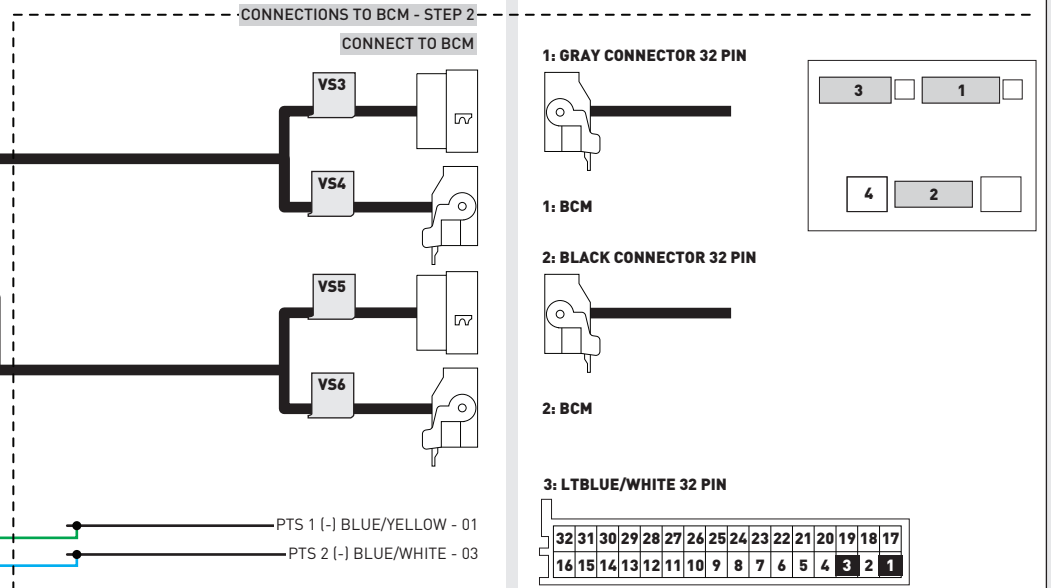
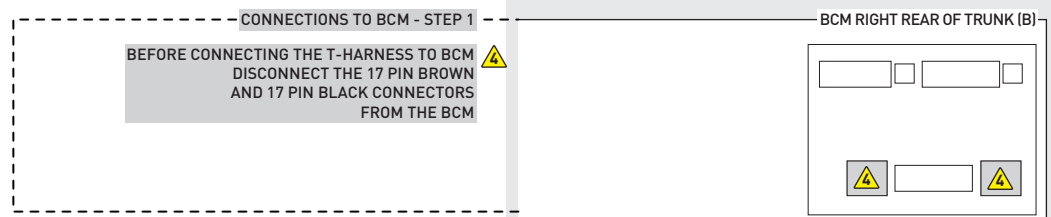



INSTALL THE SUPPLIED HOOD SWITCH IF THE VEHICLE IS NOT EQUIPPED WITH ONE.

01  When programming, only one OEM keyfob will be used. Place the other one at least 10 feet away from the vehicle.

02  Insert OEM keyfob 1 in keyport.

03  Set ignition to ON position.

04  Wait, the hazard lights will flash once [1x].

05  Wait, the ignition will turn OFF then will turn ON. (This may take up to 30 seconds)

06  Wait, the hazard lights will flash twice [2x].

07  Set ignition to OFF position.

08  Remove OEM keyfob 1 from keyport.

09  Wait, LED 1 will flash GREEN rapidly.

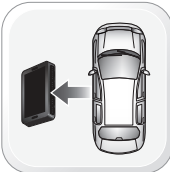
10  WARNING: Disconnect power last. Disconnect module from vehicle.

11  Connect module to computer and proceed with extended programming.

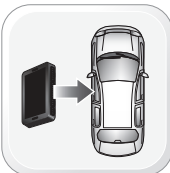
12  WARNING: Do not press module programming button. Connect power first. Connect module to vehicle.

13  Insert OEM keyfob 1 in keyport.

14  Set ignition to ON position.

15  Wait, the hazard lights will flash three times [3x].

16  Set ignition to OFF position.

17  Remove OEM keyfob 1 from keyport.

18  START vehicle for 15 seconds.

19



Press and hold the brake pedal.

20



Press the lock button of OEM keyfob 1 three times [3x].

21



Release the brake pedal.

22



Wait, the hazard lights will flash twice [2x].

23



Module Programming Procedure completed.

01 When programming, have an OEM keyfob on you. The other OEM keyfob (no battery) will remain permanently in the key box.



02 Insert OEM keyfob 1 in keyport.



03 Set ignition to ON position.



04 Wait, the hazard lights will flash once [1x].



05 Wait, the ignition will turn OFF then will turn ON. (This may take up to 30 seconds)



06 Wait, the hazard lights will flash four times [4x].



07 Set ignition to OFF position.



08 START vehicle for 15 seconds.



09 Press and hold the brake pedal.



10 Press the lock button of OEM keyfob 1 three times [3x].



11 Release the brake pedal.



12 Wait, the hazard lights will flash twice [2x].



13 Module Programming Procedure completed.

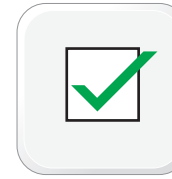

>>



All vehicle doors must be closed and locked prior to remote start sequence.

01



Time restriction. Complete steps 2 to 5 within 45 seconds.

02



Press unlock on OEM or aftermarket remote.

03



Open driver door and enter vehicle.

04



Close driver door.

05



Press and release BRAKE pedal.

06



Take over procedure completed.

>>



Failure to follow procedure will result in vehicle engine shutdown.

REMOTE STARTER ERROR CODES: NOTES	PARKING LIGHT FLASHES	DIAGNOSTIC
<p>I WARNING: The following applies only when the parking lights are connected and supported by the system.</p> <p>II After a remote starter failure, the parking lights will flash three [3x] times followed by the error code. See table.</p>	3 + 1	Tach is not programmed OR engine is already running.
	3 + 2	Key is in ignition ON position.
	3 + 3	Door is open.
	3 + 4	Trunk is open.
	3 + 5	Foot brake is ON.
	3 + 6	Hood is open.
	3 + 7	Loop is not cut.
	3 + 8	No tach detected.
	3 + 9	Vehicle movement detected (VSS).
	3 + 10	System is in Valet Mode.
	3 + 11	CAN communication failure
	3 + 12	RS not synchronized. Start vehicle with OEM key for 15 sec before trying a new RS sequence.
	3 + 13	Bypass problem.
	3 + 14	Idle mode or takeover is not available on this vehicle.
	3 + 15	Overheat protection.

REMOTE STARTER SHUTDOWN ERROR CODES: NOTES	PARKING LIGHT FLASHES	DIAGNOSTIC
<p>I WARNING: The following applies only when the parking lights are connected and supported by the system.</p> <p>II If the engine shuts down after a remote starter sequence use the query command from a compatible aftermarket remote to display the shutdown error code. The parking lights will flash four [4x] times followed by the error code. See table.</p>	4 + 1	Engine tach signal was lost.
	4 + 2	Emergency brake signal was lost.
	4 + 3	Foot brake ON detected.
	4 + 4	Hood open detected.
	4 + 5	Tach over rev detected.
	4 + 6	Glow plug timeout error.
	4 + 7	Vehicle movement detected (VSS).
	4 + 8	Check engine light ON.
	4 + 9	Low fuel level.
	4 + 10	Open door detected.
	4 + 11	CAN communication failure during RS sequence.
	4 + 12	RS not synchronized. Start vehicle with OEM key for 15 sec before trying a new RS sequence.
	4 + 13	Bypass problem.
	4 + 14	Idle mode or takeover is not available on this vehicle.
	4 + 15	Overheat protection.

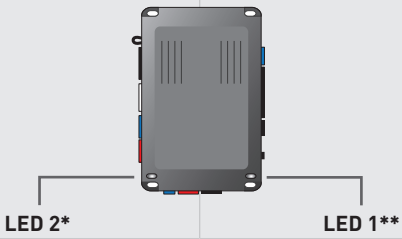
MODULE STATUS DURING:			LED STATUS	DIAGNOSTIC
	LED 2*	LED 1**		
MODULE PROGRAMMING		●	Flashing RED	Missing/wrong information from firmware or vehicle. See firmware specific diagnostics, or contact technical support.
		●	Solid RED	Module waiting for more vehicle information. Programming incomplete.
		●	Flashing GREEN	Additional steps required to complete programming. Refer to install guide.
		●	Solid GREEN then OFF	Module programming completed successfully.
		○	OFF	No activity or module already programmed.
	●		1 RED flash	No firmware on module. Connect to Weblink and flash device.
	●		2 ORANGE flashes	Contact technical support.
	●		3 ORANGE flashes	Module programming not completed.
	●		4 ORANGE flashes	Contact technical support.
	●		7 ORANGE flashes	Contact technical support.
	●		8 ORANGE flashes	Loop not cut. Ensure loop is cut for automatic transmission. Reset and re-learn.
●		9 ORANGE flashes	Loop not cut. Ensure loop is cut for automatic transmission. Reset and re-learn.	
●		10 ORANGE flashes	Boot loader update failed. Contact technical support.	
●		11 ORANGE flashes	T-harness detection does not match install type selection in Weblink.	
TACH PROGRAMMING	●		Solid RED	Tach learn in progress.
	●		1 GREEN flash	Tach signal programmed in analog.
	●		2 GREEN flashes	Tach signal programmed in data.
	●		3 RED flashes	No tach signal detected
	●		4 RED flashes	System is in valet mode. Turn off valet mode to program tach.
	●		6 RED flashes	Engine sensing set for 'assumed start'. No tach programming required.
	●		7 ORANGE flashes	Engine sensing not configured properly. Contact technical support.

* LED 2 (RS) displays generic diagnostic codes specific to the remote start module. Orange LED flashes may appear red.

** LED 1 (Bypass) displays diagnostic codes specific to the firmware loaded on the module.

Visit the programming diagnostics page for more information.

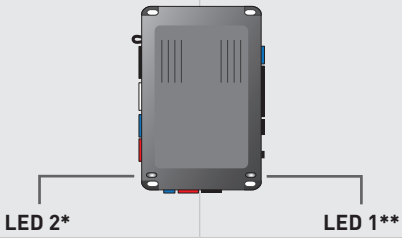

MODULE STATUS DURING:			LED STATUS	DIAGNOSTIC
	LED 2*	LED 1**		
REMOTE START SEQUENCE	●		Flashing rapid RED	Remote start shutdown sequence.
	●		Flashing slow RED	Remote start shutdown error code. Contact technical support.
	●		Solid RED	Remote start crank delay.
	●		Flashing rapid GREEN	Remote start cycle in progress. Working correctly.
	●		1 GREEN flash	Remote start initiated successfully.
	●		3 GREEN flashes	Idle mode cycle in progress.
	●		4 GREEN flashes	Turbo mode cycle in progress.
TRANSMITTER PROGRAMMING		●	Flashing GREEN	Remote start cycle in progress. Displays vehicle platform during runtime.
		●	Rapid GREEN flashing	Secure takeover initiated. Waiting to complete takeover after brake press.
	●		Solid RED	Remote programming in progress, waiting for remote pairing.
	●		1 GREEN flash	Remote programmed.
	●		4 RED flashes	Shutdown remote starter before attempting remote programming.
	●		5 RED flashes	Engine must be off before attempting remote programming.
	●		6 RED flashes	System must be unlocked/disarmed before attempting remote programming.
			7 RED flashes	Module must be learned to the vehicle before attempting remote programming.

* LED 2 (RS) displays generic diagnostic codes specific to the remote start module. Orange LED flashes may appear red.

** LED 1 (Bypass) displays diagnostic codes specific to the firmware loaded on the module.

Visit the programming diagnostics page for more information.

