



INSTALL GUIDE

2011 NISSAN ROGUE WITH INTELLI-KEY SUV AUTOMATIC



DOCUMENT NUMBER

A21376E

REVISION DATE

20200918_182500

FIRMWARE

RSA-NI4T

HARDWARE

CMHCXA0

ACCESSORIES

ATTENTION: TO COMPLETE THIS INSTALLATION SOME ACCESSORIES MAY BE REQUIRED. VISIT OUR WEBSITE TO SEE ALL THE REQUIRED ACCESSORIES FOR YOUR VEHICLE.

TERMS OF USE

Automotive Data Solutions Inc. ("ADS") products are strictly intended for installation by Certified Technicians who are employed by a registered business specialized in the installation of automotive aftermarket electronics products. Prior to beginning installation of an ADS product in a vehicle, it is the Certified Technician's responsibility to review the most current Product Guide, Install Guide and vehicle-specific notes available in Weblink®. ADS is not responsible for any damages whatsoever, including but not limited to any consequential damages, incidental damages, damages for loss of time, loss of earnings, loss of profit, commercial loss, loss of economic opportunity and the like that may or may not have resulted from the use, misuse, improper installation or operation of its products. ADS reserves itself the right to suspend any Weblink® account without notice and decline to offer technical support to non-Certified Technicians, noncompliant Certified Technicians or end users.

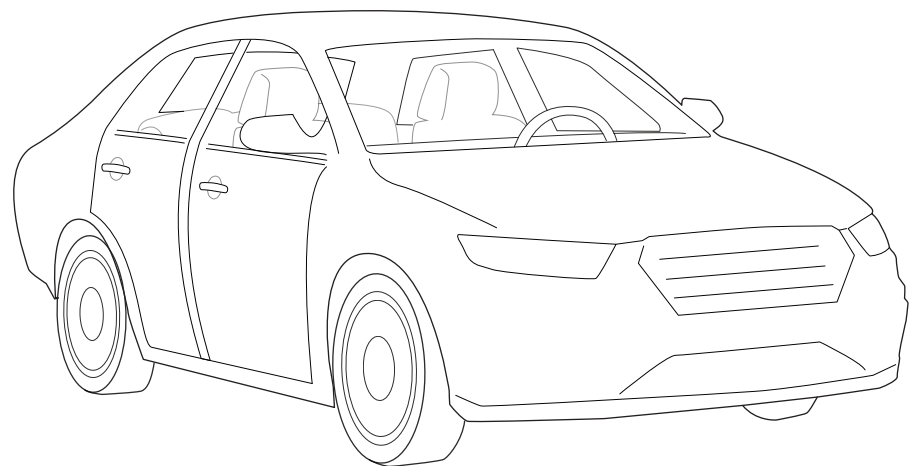
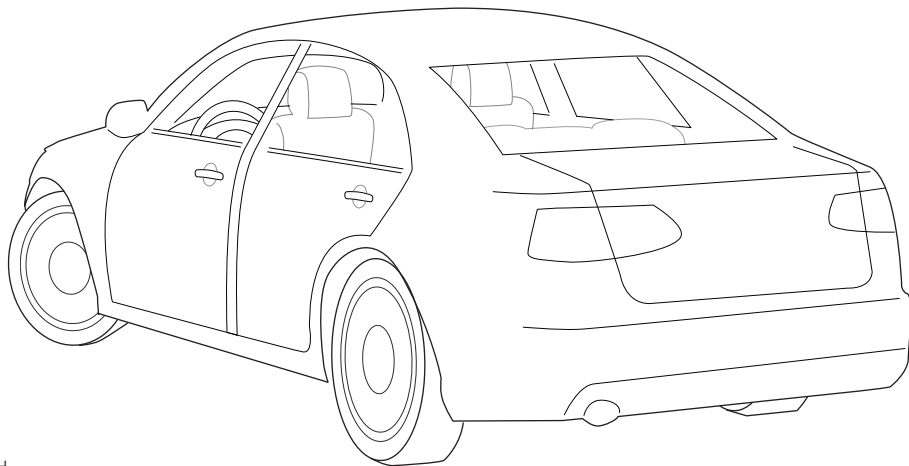
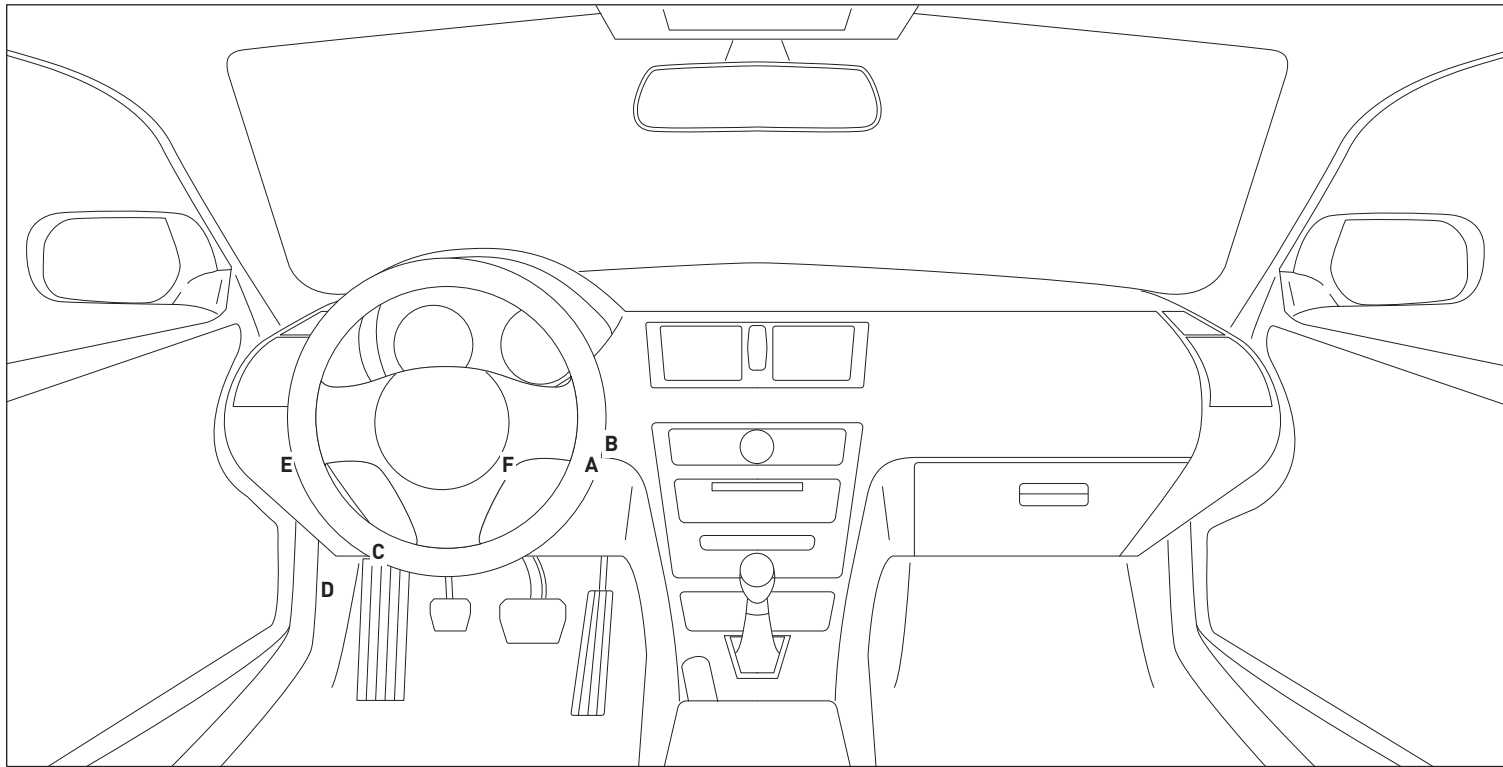

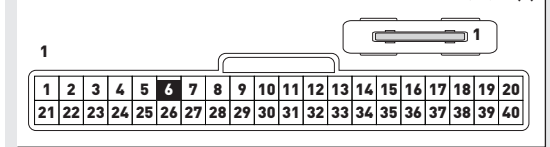
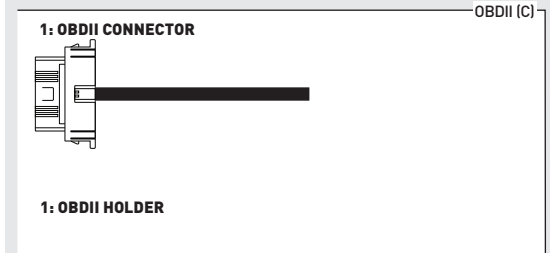
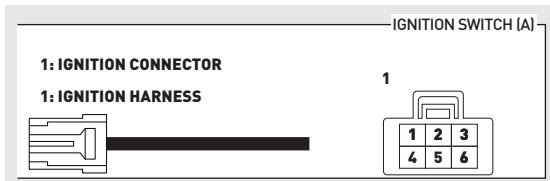
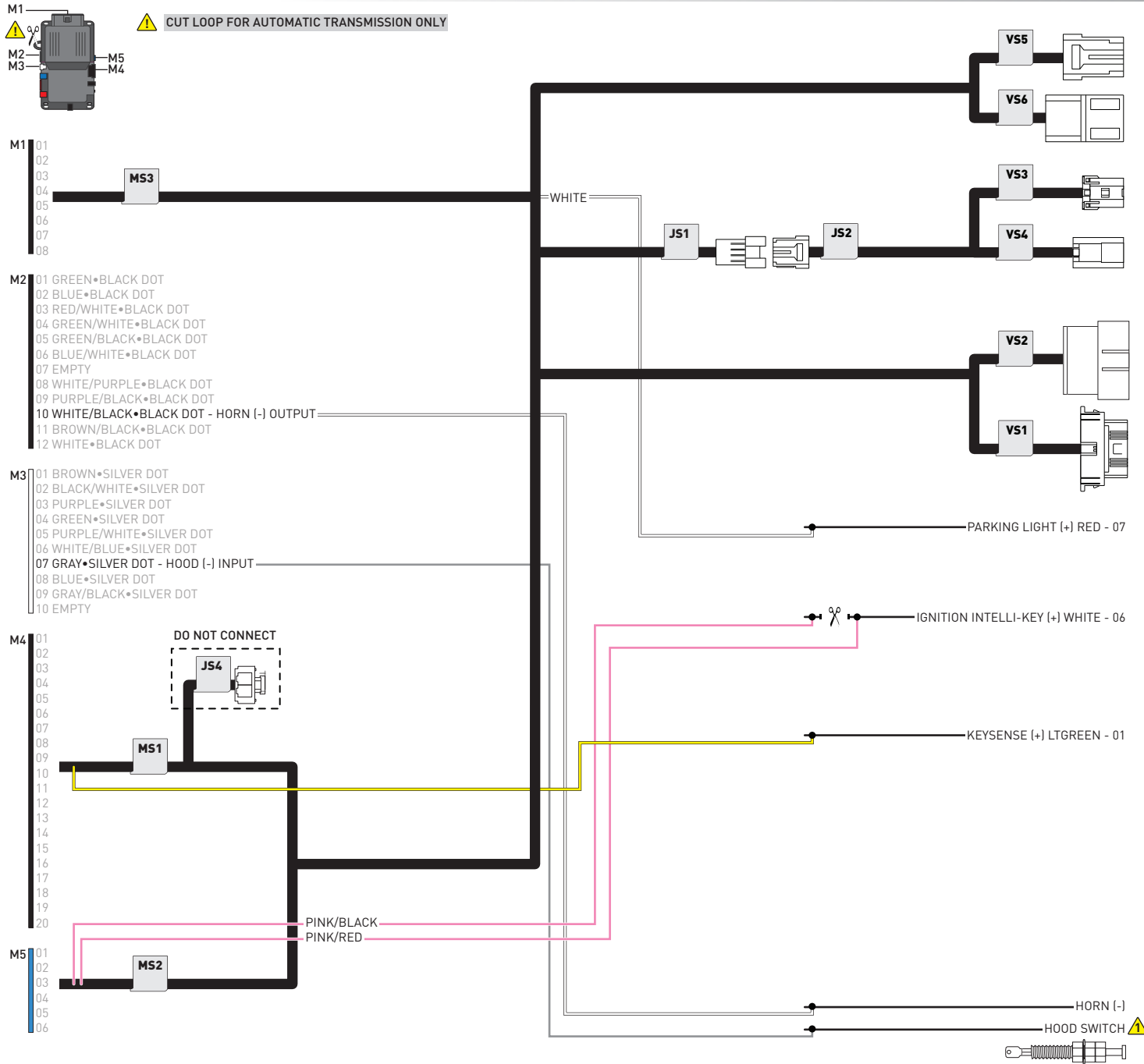

INSTALL THE SUPPLIED HOOD SWITCH IF THE VEHICLE IS NOT EQUIPPED WITH ONE.

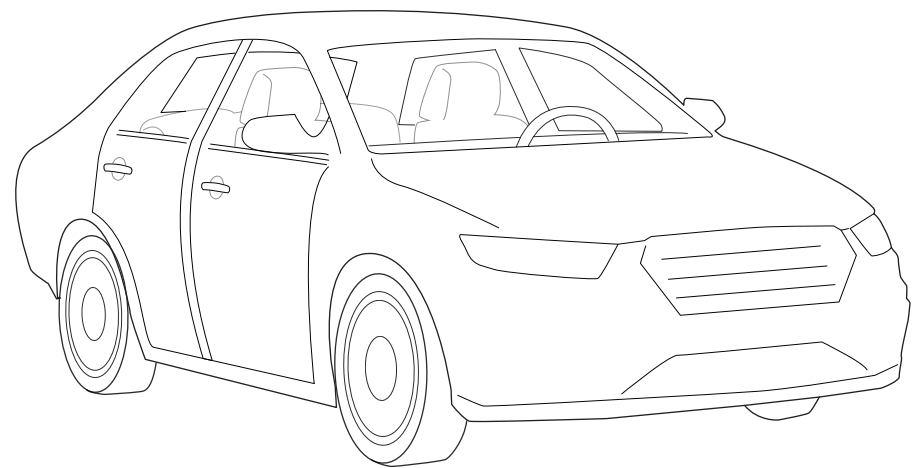
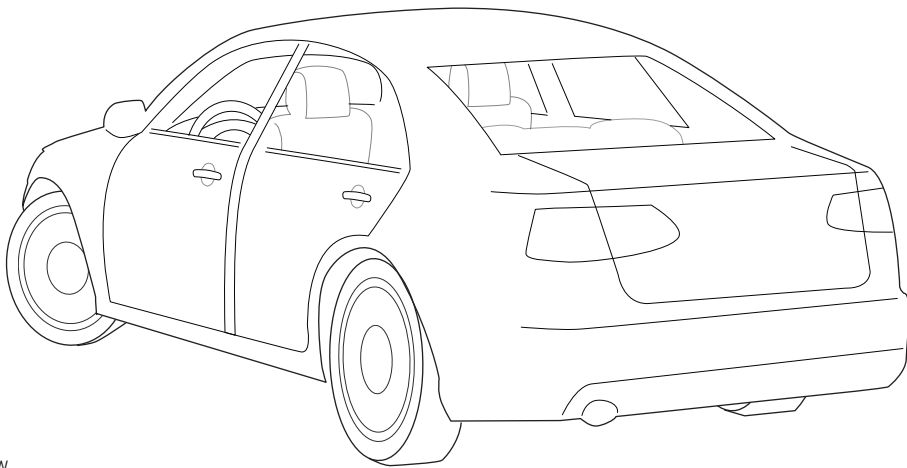
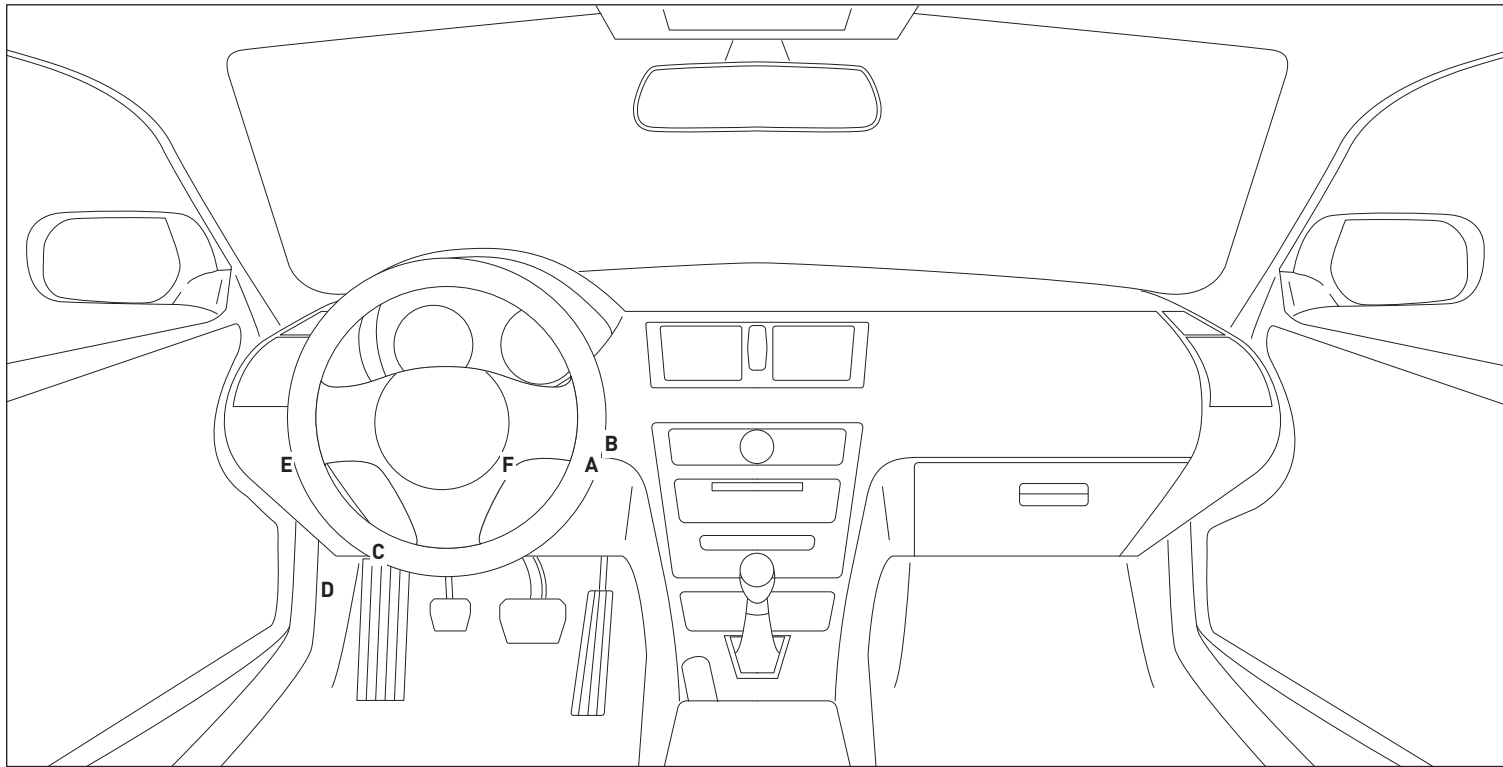

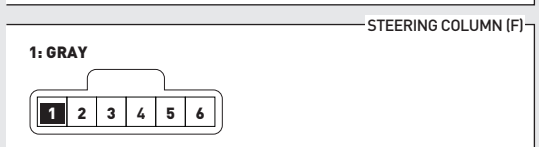
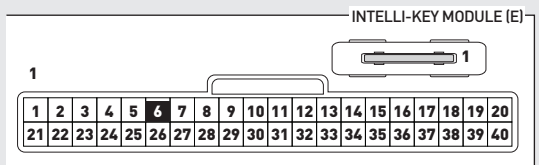
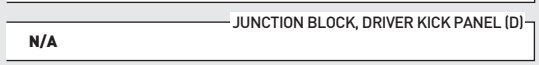
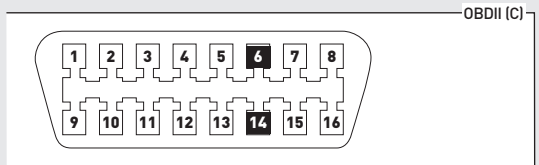
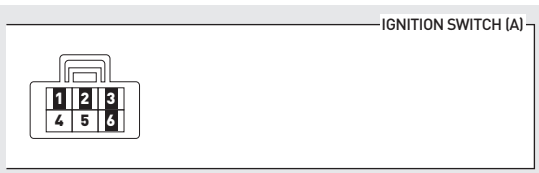
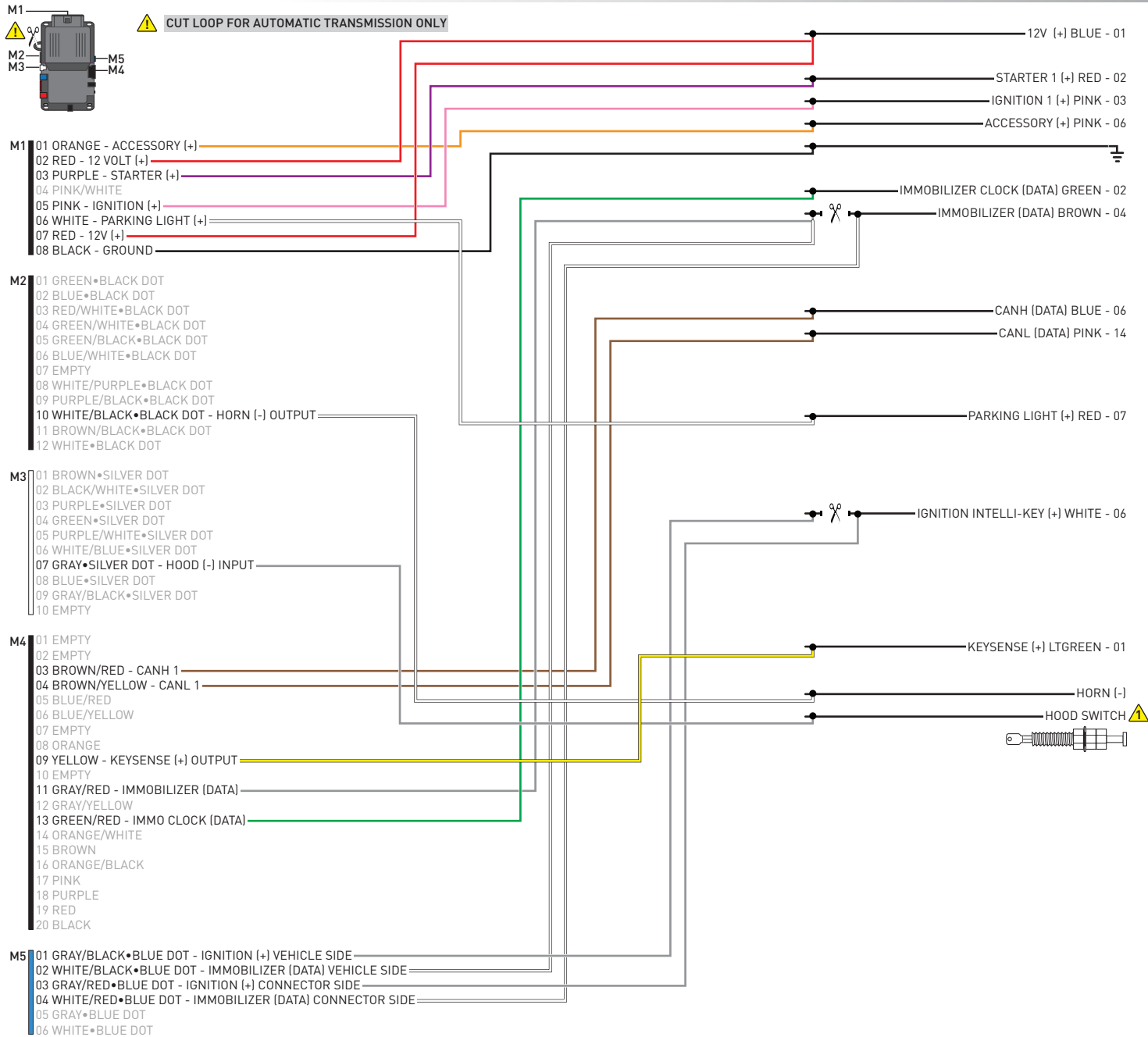

INSTALL THE SUPPLIED HOOD SWITCH IF THE VEHICLE IS NOT EQUIPPED WITH ONE.

01 To complete this procedure, use one valet key.

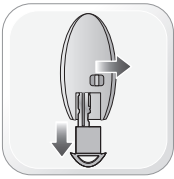

02 When programming, all key fobs must be located at least 10 feet away from the vehicle.



03 Set ignition to ON position.



04 Wait, LED 1 will turn solid GREEN for 2 seconds.



05 Set ignition to OFF position.



06 START vehicle for 15 seconds.



07 Press and hold the brake pedal.



08 Press and release the module's programming button.



09 Release the brake pedal.



10 Wait, LED 2 will flash GREEN.



11 Module Programming Procedure completed.



>>



All vehicle doors must be closed and locked prior to remote start sequence.

01



Press unlock on OEM or aftermarket remote or request switch.

02



DO NOT PRESS BRAKE PEDAL. Set ignition to ON position. Wait 2 seconds for key validation.

03



Press and release BRAKE pedal.

04



Take over procedure completed.

>>



Failure to follow procedure will result in vehicle engine shutdown.

CHECKLIST - WITH AFTERMARKET KEYFOB

1	WARNING: Vehicle engine will start many times. Test in a well ventilated area.
2	Close all vehicle doors, hood and trunk.
3	Press the LOCK button once [1x] on the aftermarket keyfob.
	Question 1: Do the doors lock?
<input type="checkbox"/>	YES: Go to next step.
<input type="checkbox"/>	NO: Verify the remote programming, the RF connections and the wired door lock/unlock connections as illustrated in the wiring diagram, if applicable. Repeat the test and call technical support, if the problem persists.
4	Press the UNLOCK button once [1x] on the aftermarket keyfob.
	Question 2: Do the doors unlock?
<input type="checkbox"/>	YES: Go to next step.
<input type="checkbox"/>	NO: Verify the remote programming, the RF connections and the wired door lock/unlock connections as illustrated in the wiring diagram, if applicable. Repeat the test and call technical support, if the problem persists.
5	Press the TRUNK release button once [1x] on the aftermarket keyfob if supported.
	Question 3: Does the trunk or hatch open/unlock?
<input type="checkbox"/>	YES: Close trunk or hatch and go to next step.
<input type="checkbox"/>	NO: Verify the remote programming, the RF connections and the wired trunk/hatch connections as illustrated in the wiring diagram, if applicable. Repeat the test and call technical support, if the problem persists.
6	Press the AUX 1 button once [1x] on the aftermarket keyfob if supported.
	Question 4: Does the driver side sliding door open?
<input type="checkbox"/>	YES: Press the AUX 1 button once [1x] to close the driver sliding door and go to next step.
<input type="checkbox"/>	NO: Verify the remote programming and the RF connections. Repeat the test and call technical support, if the problem persists.
7	Press the AUX 2 button once [1x] on the aftermarket keyfob if supported.
	Question 5: Does the passenger side sliding door open?
<input type="checkbox"/>	YES: Press the AUX 2 button once [1x] to close the passenger sliding door and go to next step.
<input type="checkbox"/>	NO: Verify the remote programming and the RF connections. Repeat the test and call technical support, if the problem persists.
8	Press the START/STOP button once [1x] on the aftermarket keyfob to remote start vehicle.
	Question 6: Does the vehicle remote start?
<input type="checkbox"/>	YES: Go to next step.
<input type="checkbox"/>	NO: Verify the remote programming, the RF connections and check the remote start error codes. Repeat the test and call technical support, if the problem persists.

9	Press the START/STOP button once [1x] on the aftermarket keyfob to shut down vehicle.
	Question 7: Does the vehicle shut down?
<input type="checkbox"/>	YES: Go to next step.
<input type="checkbox"/>	NO: Repeat step. If problem persists, press the brake pedal once [1x] to shut down the vehicle and call technical support.
10	RAP and auto light shutdown test
	Question 8: Did the radio, interior controls and headlights turn off within 60 seconds after remote start shutdown?
<input type="checkbox"/>	YES: Go to next step.
<input type="checkbox"/>	NO: Verify the RAP SHUTDOWN connections as illustrated in the wiring diagram. Repeat the test and call technical support if the problem persists.
11	Open hood.
12	If not already installed, affix the mandatory orange warning sticker under the hood and proceed to next step.
13	Press the START/STOP button once [1x] on the aftermarket keyfob to remote start vehicle.
	Question 9: Does the vehicle remote start?
<input type="checkbox"/>	YES: The vehicle is not equipped with a factory hood pin. Install a mandatory aftermarket hood switch, then repeat the test.
<input type="checkbox"/>	NO: Go to next step.
14	Close hood.
15	Enter vehicle and close the doors.
16	Press the START/STOP button once [1x] on the aftermarket keyfob to remote start vehicle.
17	Wait for the vehicle to start.
18	Press brake pedal.
	Question 10: Does the vehicle shut down?
<input type="checkbox"/>	YES: Go to next step.
<input type="checkbox"/>	NO: The module does NOT detect the brake pedal signal. Press the START/STOP button once [1x] on the aftermarket keyfob to shut down vehicle, check connection as illustrated in the wiring diagram, if applicable, and call technical support.
19	Exit vehicle.
20	Installation checklist completed.

CHECKLIST - WITH OEM KEYFOB

1	WARNING: Vehicle engine will start many times. Test in a well ventilated area.
2	Close all vehicle doors, hood and trunk.
3	Press LOCK button three times [3x] rapidly on the OEM keyfob to remote start vehicle.
	Question 1: Does the vehicle remote start?
<input type="checkbox"/>	YES: Go to next step.
<input type="checkbox"/>	NO: The module doesn't detect OEM remote lock button from the vehicle communication network. Check all connections, repeat the test and call technical support, if the problem persists.
4	Press LOCK button three times [3x] rapidly on the OEM keyfob to shut down vehicle.
	Question 2: Does the vehicle shut down?
<input type="checkbox"/>	YES: Go to next step.
<input type="checkbox"/>	NO: Repeat step. If the problem persists, press on the brake pedal once [1x] to shut down the vehicle and call technical support.
5	RAP Shutdown test
	Question 3: Did the radio, interior controls, and headlights turn off within 60 seconds after remote start shutdown?
<input type="checkbox"/>	YES: Go to next step.
<input type="checkbox"/>	NO: Verify the RAP SHUTDOWN connections as illustrated in the wiring diagram. Repeat the test and call technical support, if the problem persists.
6	Open hood.
7	If not already installed, affix the mandatory orange warning sticker under the hood and proceed to next step.
8	Press LOCK button three times [3x] rapidly on the OEM keyfob to remote start vehicle.
	Question 4: Does the vehicle remote start?
<input type="checkbox"/>	YES: The vehicle is not equipped with a factory hood pin. Install a mandatory aftermarket hood switch, then repeat the test.
<input type="checkbox"/>	NO: Go to next step.
9	Close hood.
10	Enter vehicle and close the doors.
11	Press LOCK button three times [3x] rapidly on the OEM keyfob to remote start vehicle.
12	Wait for the vehicle to start.
13	Press brake pedal.
	Question 5: Does the vehicle shut down?
<input type="checkbox"/>	YES: Go to next step.
<input type="checkbox"/>	NO: The module does NOT detect the brake pedal signal. Press LOCK button three times [3x] rapidly on the OEM keyfob to shut down, check the brake connection as illustrated in the wiring diagram, if applicable, and call technical support.
14	Exit vehicle.
15	Installation checklist completed.