



# FLRSBA



## MASTER GUIDE DIGITAL REMOTE STARTER + ALARM

**VOXX Electronics Corp**

150 Marcus Blvd

Hauppauge, NY 11788

Technical support: **VOXX** 800.225.6074

Technical support: **CODE ALARM** 800.421.3209

Please visit [www.flashlogic.com](http://www.flashlogic.com) for additional installation resources

REV 03042023

## Table of Contents

---

<b>Wiring Diagram</b>	<b>3</b>
<b>Introduction</b>	<b>4</b>
<b>Kit Contents</b>	<b>4</b>
<b>Installation Basics</b>	<b>4</b>
<b>BASEC Security Activation procedure</b>	<b>6</b>
<b>Remote Programming Routine (Prestige / Pursuit)</b>	<b>7</b>
<b>Remote Programming Routine (Code Alarm)</b>	<b>8</b>
<b>Valet Modes</b>	<b>9</b>
<b>Placement and Use of Components</b>	<b>15</b>
<b>Tach sensing &amp; learning</b>	<b>16</b>
<b>System reset</b>	<b>17</b>
<b>Wiring Descriptions</b>	<b>18</b>
<b>Option Programming Tables</b>	<b>23</b>
<b>Option Menu Descriptions</b>	<b>33</b>
<b>Troubleshooting</b>	<b>55</b>
<b>Frequently Asked Questions</b>	<b>57</b>
<b>Technical Support Contacts</b>	<b>59</b>

# Wiring diagram

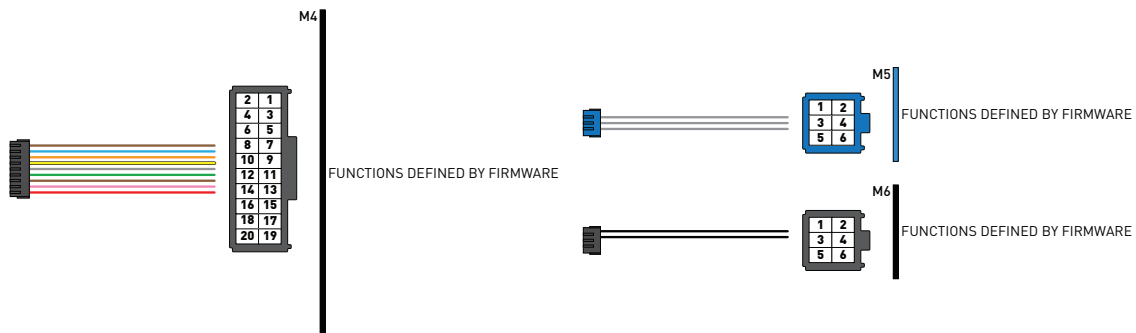
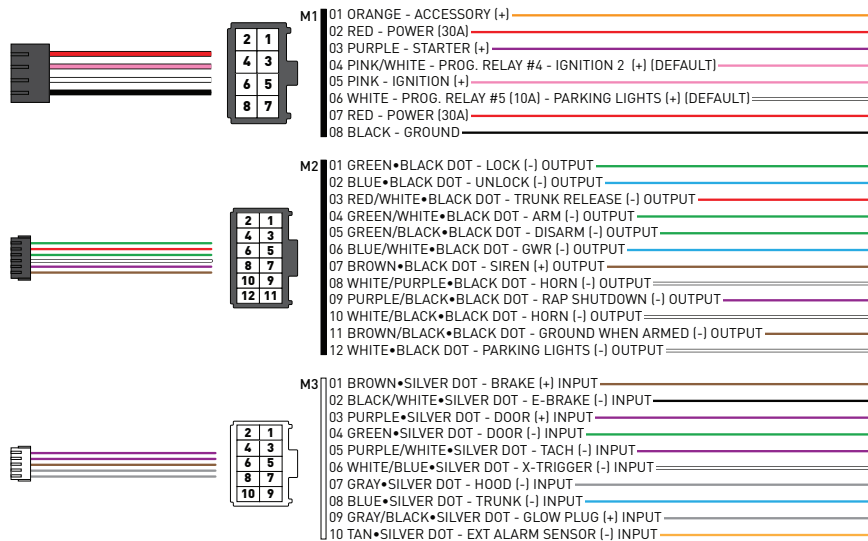
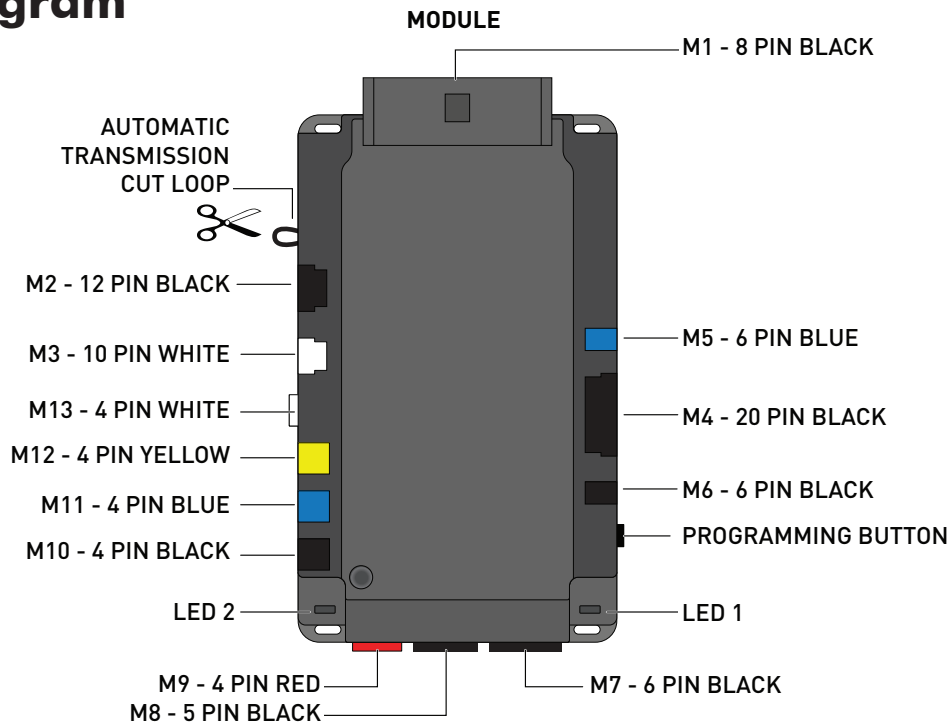

## Introduction

Thank you for purchasing this Voxx system for your vehicle. The following installation manual is intended for experienced and authorized Voxx technicians. We highly recommend that you contact your local Voxx dealer and seek professional installation. Call 800.225.6074 (Voxx) or 800.421.3209 (Code Alarm) or visit our website at [www.flashlogic.com](http://www.flashlogic.com) to locate your nearest dealer. If you need additional or replacement remotes and/or online support please visit [www.flashlogic.com](http://www.flashlogic.com).



Caution: The Manufacturer's warranty will be void if this product is installed by anyone other than an authorized Voxx dealer. Voxx provides installation support services to authorized dealers only. This manual may change frequently. Please check [www.flashlogic.com](http://www.flashlogic.com) for updates.

## Kit Contents

All Voxx FLRSBA controllers include the following:

- FLRSBA main control module with built-in shock/tilt sensor\*
- Low current ignition harness
- Wiring harnesses
- Hood pin

\* Internal shock/tilt sensor and siren output require activation. See '**BASEC security activation**' page.

RF Kits with remote(s), Antenna, and Antenna Cable are not included with the FLRSBA.

The following accessories are available but **not included** with every system:

- High-Current power harness **ADSAHRPWR**
- mSense manual transmission digital sensor **ACC-MTDS1**
- Digital tilt sensor **DUB1**
- Glass beak sensor **CAGBS**
- Field disturbance/movement sensor **MV3**
- Dual stage piezo shock sensor **AS9492**
- Dual stage infrasonic shock sensor **AS94954P**

The remote(s) and antenna are modular and are not specific to the control modules. You have the ability to pair most Voxx and Code Alarm remote(s) with a 4, 5, or 6-pin antenna receiver to the FLRSBA. Carlink telematic devices are also supported on the (M11) 4-pin Blue port. Any questions on contents please contact your distributor or us directly at 800.225.6074 (Voxx) or 800.421.3209 (Code Alarm)

## Installation Basics

If you are new to installing Voxx FLRSBA Series Remote Starts and/or Alarms, we highly recommended that you thoroughly review this manual to installing your first unit.



**BLACK loop must be cut for AUTOMATIC transmission vehicles.**

You must cut the loop to confirm installation into an automatic transmission vehicle. The module will not program to the vehicle or remote start if the loop is not cut.

## Installation Basics cont...

### **Flashing firmware to the FLRSBA on the web:**

Before you can use your FLRSBA, it must be connected to the internet and flashed with firmware tailored to the vehicle you are installing on. To connect to the module to your computer, you will need the Weblink USB PC programmer (available from your distributor). Then visit <http://www.flashlogic.com> to flash your module. You will need to create an account if you don't already have one. You can also program the FLRSBA using the Weblink Mobile adapter for iOS or Android. The Weblink Mobile RS app is available through iTunes or Google Play.

PLEASE NOTE: All FLRSBA's are shipped without any firmware loaded at the factory.

### **Configuring options:**

During or after flashing the module online (see above) you can configure programmable options for remote start/Doorlocks/Alarm and more (See Option Programming Tables). PLEASE NOTE: These options can only be configured online or with our mobile apps.

### **System programming:**

Make sure the CM has been flashed on the web, and that all the required connections have been made. Plug in all the connectors starting with M1. Cycle the vehicle's ignition ON, the CM led's will go solid GREEN, then out. Programming is complete - Perform the Tach learning procedure.

### **Tach learning procedure:**

Learn tach by: (1.) Starting the vehicle with the key, (2.) Press and hold the foot brake, then (3.) Press and release the programming button on the FLRSBA - one or two GREEN flashes (module led) indicates that the vehicle tach signal has been successfully learned. Release the foot brake. Three or more RED flashes (module led) indicates that the control module failed to see a proper tach signal. Consult the 'Tach sensing and learning' section for more info and parklight flash diagnostics. (These units also have the option for assumed start).

### **Remote Programming:**

If you are adding Voxx or Code Alarm transmitters to your installation, you must code the remotes to the system before they will operate. The procedure for programming different brands of transmitters is detailed in the '**Remote programming routine**' section of this guide.

IMPORTANT: Remote can only be learned once the main module has been programmed to the vehicle.

### **Built-in shock/tilt Sensor (BASEC activation required):**

The FLRSBA features a dual stage impact, and auto adjusting tilt sensor. See the 'BASEC security activation' page for instructions on use and adjustment.

### **High Current 2nd Ignition Output (M1 Pink/White Wire) (Web Programmable)**

### **High Current Parking Light Output (M1 White Wire) (Web Programmable)**

### **Carlink data port (Blue M11) for use with Carlink ASCL6, ASCLBTLR.**

## BASEC security activation

To activate full security features such as Siren output and Shock sensor, you will need an activation card with an unlock code.

Activations are linked to the device, so you can flash the device multiple times for different vehicles without affecting the activation status.

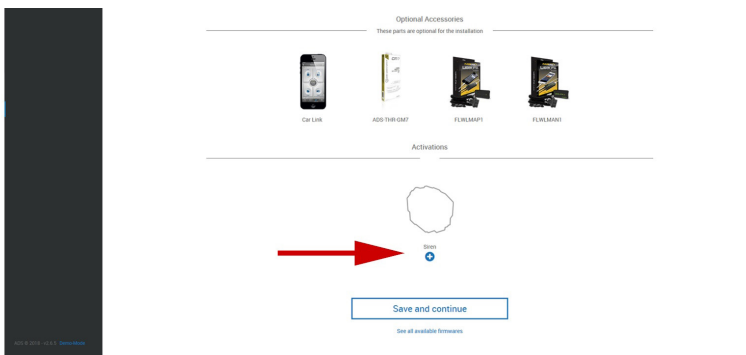

Connect your FLRSBA to weblink. When you reach the firmware selection page in the flash process, you will see the siren button in the 'Activations' section below the optional accessories.

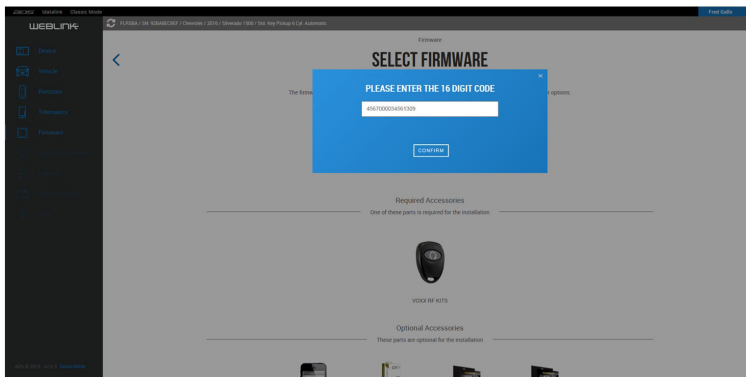

Click the '+' sign to enter the 16-digit code found on your BASEC activation card. Then click 'CONFIRM'.

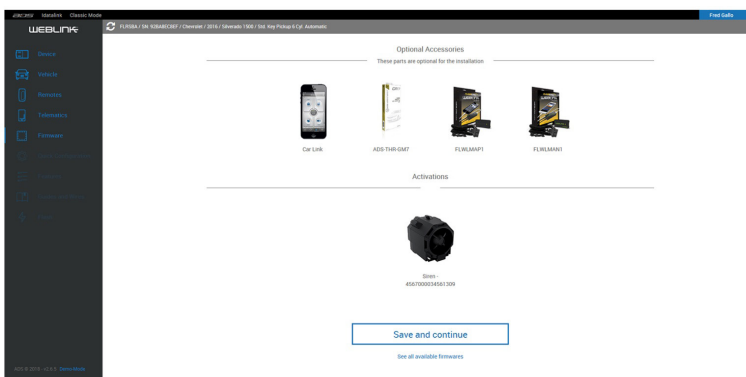

A siren image will appear in the 'Activations' section of the screen confirming your code. When you complete your flash, the FLRSBA will be activated with full security features.

## Remote Programming Routine - PRESTIGE / PURSUIT

**IMPORTANT:** The FLRSBA must be flashed with the appropriate firmware (see 'Installation Basics' section) and programmed to the vehicle before transmitters can be learned to the system.

A maximum of (4) transmitters can be learned to the system.

01 Set ignition to ON position.



02 Press and release the antenna button three times [3x].



03 The parking lights will flash once [1x], the horn will chirp once [1x].



04 The remote starter LED will turn RED and the antenna LED will flash.



05 Press once [1x] on LOCK button of aftermarket remote.



06 The remote starter LED will flash GREEN once [1x] then will turn RED.



07 To program additional remotes: repeat steps 5 to 6 using each additional remote.



08 Set ignition to OFF position.



09 The remote starter LED will turn OFF and the antenna LED will turn OFF.

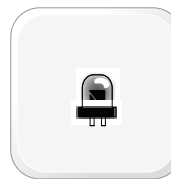

10 The parking lights will flash twice [2x], the horn will chirp twice [2x].

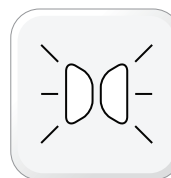

11 Remote Programming completed.

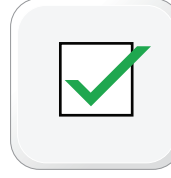











>> TO DELETE ALL REMOTES: repeat steps 1 to 4 then press and hold the antenna button for 6 seconds. The parking lights will flash twice [2x], the horn will chirp twice [2x].



## Remote Programming Routine - CODE ALARM

**IMPORTANT:** The FLRSBA must be flashed with the appropriate firmware (see 'Installation Basics' section) and programmed to the vehicle before transmitters can be learned to the system.

A maximum of (4) transmitters can be learned to the system.

- 01  Set ignition to ON position.
- 02  Press and hold the antenna button for 10 seconds.
- 03  The parking lights will flash three times [3x], the horn will chirp three times [3x].
- 04  The remote starter LED will turn RED and the antenna LED will flash.
- 05  Press once [1x] on LOCK button of aftermarket remote.
- 06  The remote starter LED will flash GREEN once [1x] then will turn RED.
- 07  To program additional remotes: repeat steps 5 to 6 using each additional remote.
- 08  Set ignition to OFF position.
- 09  The remote starter LED will turn OFF and the antenna LED will turn OFF.
- 10  The parking lights will flash three times [3x].
- 11  Remote Programming completed.

## Valet Mode

Valet Mode disables all or some of the system's features. Use Valet when servicing or loaning your vehicle to others to avoid any inconvenience or mishap when operating the vehicle. There is a parking light indication when attempting remote starting in Valet Mode: (3 flashes followed by 10 flashes). Also when in Valet Mode, the keyless entry feature will still operate. There are multiple options available for setting valet mode (see menu option 1-17). Below is the most popular as it does not require a transmitter or antenna, and it is best adapted to PTS vehicles.

>>  The following procedure is valid for PRESTIGE and PURSUIT RF kits. It triggers the Valet Mode for remote start and alarm if the alarm override option is set to valet switch (Menu 3, Option 22).

01  NOTE: In Valet Mode, the Remote starter is not functional. Keyless entry, Lock and Unlock will remain functional.

02  Cycle ignition ON twice [2x OFF/ON] rapidly.

03  Press and release the BRAKE pedal three times [3x].

04  The parking lights will flash once [1x], the horn will chirp once [1x], the antenna LED will turn ON.

05  Set ignition to OFF position.

06  Valet Mode completed.

07  To exit valet mode, repeat steps 2 to 3. The parking lights will flash twice [2x], the horn will chirp twice [2x], the antenna LED will turn OFF.

## Valet Mode (remote start only) for Prestige or Pursuit RF kits

Disables only the remote start function of the system. Alarm and keyless entry remains active. Menu option 3-22 must be set for 'Valet switch' (default).

>>

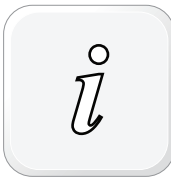

The following procedure is valid for PRESTIGE and PURSUIT RF kits. It triggers the Valet Mode for remote start only.

01



NOTE: In Valet Mode, the Remote starter is not functional. Keyless entry, Lock and Unlock will remain functional.

02



Set ignition to OFF position.

03



Press and hold the antenna button.

04



Cycle ignition ON three times [3x ON/OFF] rapidly.

05



The parking lights will flash once [1x], the horn will chirp once [1x], the antenna LED will flash twice [2x] rapidly then once [1x].

06



Valet Mode completed.

07



To exit valet mode, repeat steps 2 to 4. The parking lights will flash twice [2x], the horn will chirp twice [2x], the antenna LED will turn OFF.

## Valet Mode (alarm only) for Prestige or Pursuit RF kits

Disables only the alarm functions of the system. Remote start and keyless entry remains active. Menu option 3-22 must be set for 'Valet switch' (default).

>>



The following procedure is valid for PRESTIGE and PURSUIT RF kits. It triggers the Valet Mode for alarm only.

01



NOTE: In Valet Mode, the alarm is disabled and the Remote starter is functional. Keyless entry, Lock and Unlock will remain functional.

02



Set ignition to ON position.

03



Press and hold the antenna button for 5 seconds.

04



The parking lights will flash once [1x], the horn will chirp once [1x], the antenna LED will turn ON.

05



Set ignition to OFF position.

06



Valet Mode completed.

07



To exit valet mode, repeat steps 2 to 3. The parking lights will flash twice [2x], the horn will chirp twice [2x], the antenna LED will turn OFF.

## Valet Mode (custom code option) for Prestige or Pursuit RF kits

Disables the entire system using a custom code override (**default code is 11**).

Keyless entry remains active.

Menu option 3-22 must be set for 'Custom code option'.

>>



The following procedure is valid for PRESTIGE and PURSUIT RF kits. It triggers the Valet Mode with a custom code override. The default override code is 11.

01



NOTE: In Valet Mode, the Remote starter is not functional. Keyless entry, Lock and Unlock will remain functional.

02



Set ignition to ON position.

03



Press the antenna programming button once [1x].

04



Cycle ignition ON once [1x OFF/ON] rapidly.

05



Press the antenna programming button once [1x].

06



Cycle ignition ON once [1x ON/OFF] rapidly.

07



Set ignition to START position. (Engine running.)

08



Set ignition to OFF position.

09

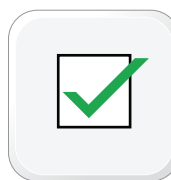

Valet Mode completed.

## Valet Mode (set new custom code) for Prestige or Pursuit RF kits

This procedure lets you set a new custom code override (**default code is 11**) to set valet mode. Keyless entry remains active. Menu option 3-22 must be set for 'Custom code option'.

>>



The following procedure is valid for PRESTIGE and PURSUIT RF kits. It sets a new custom code override to trigger the Valet Mode.

01



Press once [1x] on the unlock button of the aftermarket remote.

02



Set ignition to ON position.

03



TIME RESTRICTION. Complete steps 4 to 9 within 45 seconds.

04



Press the antenna programming button three times [3x].

05



Cycle ignition ON three times [3x OFF/ON] rapidly.

06



Press the antenna programming button up to 9 times, to set the tenths digit from 1 to 9. Each button press increments the digit by one.

07



Cycle ignition ON once [1x OFF/ON] rapidly.

08



Press the antenna programming button up to 9 times, to set the tenths digit from 1 to 9. Each button press increments the digit by one.

09



Set ignition to OFF position.

10



LED will flash as many times as the tenths digit, then will flash as many times as the units digit.

11



Valet Mode completed.

## Valet Mode (alarm & remote start) for CODE ALARM RF kits

Disables the alarm and remote start functions of the system. Keyless entry remains active. Menu option 3-22 must be set for 'Valet switch' (default).

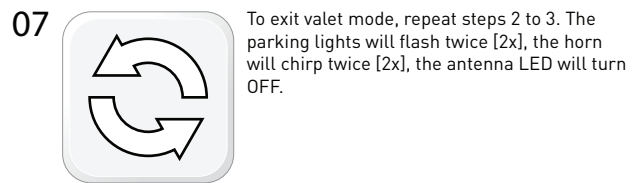
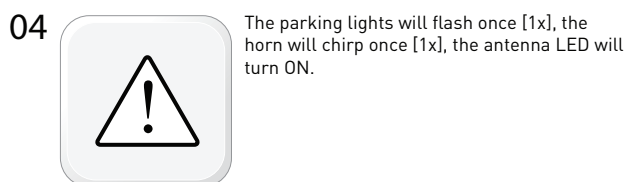
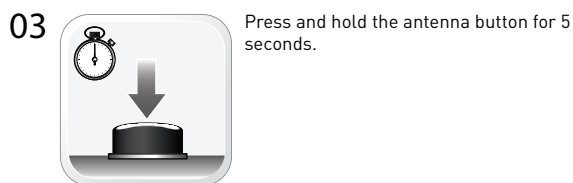
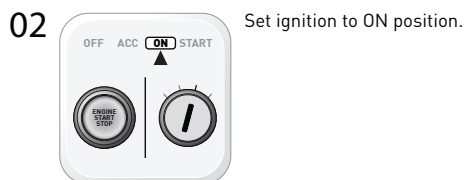
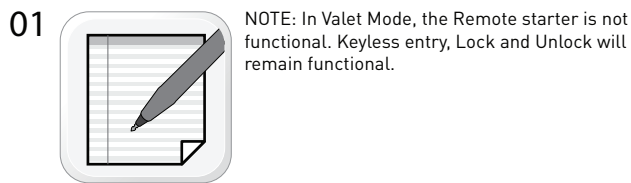
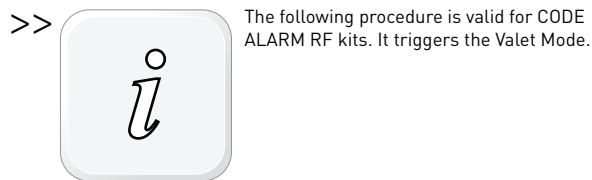

## Placement and Use of Components

**IMPORTANT:** The placement and use of components are critical to the performance of this system.

### Antenna and Cable

Voxx antennas are calibrated for vertical installation at the top of the windshield. The cable that connects the antenna to the control module must be free from any pinches or kinks. Installing the antenna in areas other than the windshield may adversely affect the effective transmitting distance of the remotes.

### FLRSBA main module

Installation flexibility with the main module depends on if you are using the BASEC security features (built-in shock/tilt sensor).

#### Without BASEC

The module should be properly secured to avoid exposure to rattles, moisture, excessive heat, or moving parts. Use the module's built-in tie-wrap holes when possible.

#### With BASEC

A suitable location should be chosen that allows for the best overall performance of the built-in shock sensor. The tilt feature is auto setting, so orientation is not a factor. The module should be properly secured to avoid exposure to rattles, moisture, excessive heat, or moving parts. Use the module's built-in tie-wrap holes when possible.







### Siren

The optional siren is mounted under the hood, or another location that provides a path for sound to the outside of the vehicle. The siren should be properly secured to avoid exposure to rattles, moisture, excessive heat, or moving parts. The FLRSBA siren output is only functional when the BASEC security features have been activated. (See 'BASEC security activation' section)

### Hood Pin

The hood pin switch triggers the alarm in the event the hood is opened while the alarm is armed. The hood pin doubles as an important safety feature that prevents the remote start from engaging while the hood is open.

## Tach sensing & learning

- 01  START vehicle for 15 seconds. Proceed to step 2 within 60 secondsd
- 02  Press and hold the brake pedal.
- 03  Press and release the module's programming button. (OR if the remotes are already programmed to the vehicle, press and hold the start button of the remote for 2.5 seconds.)
- 04  Wait, LED 2 will flash GREEN. (See the Module Diagnostics page)
- 05  Release the brake pedal.
- 06  Module Programming Procedure completed.

### Tach Sensing

The default engine sensing mode is tach. In cold weather climates we recommend using an injector wire verses a computer "data" signal, or a coil wire for tachometer sense. Voxx recommends using a digital multimeter when testing for tach.

**STEP 1:** Start the vehicle with the key. Allow time for the engine to idle down. (If you do not want to wait for the vehicle to idle down, you can shift the vehicle into reverse while holding your foot on the brake.)

**STEP 2:** Test wire and make connection. At idle, the tach wire should test between 1 to 4 Volts AC.

As the vehicle RPM's increase the voltage on the meter will also increase. Always make a wire to wire connection for tach.

**STEP 3:** Learn tach: Start the vehicle, press and hold the foot brake. Press and release the module's programming button. (OR if the remotes are already programmed to the vehicle, press and hold the start button of the remote for 2.5 seconds.) Wait, LED 2 will flash GREEN. (See the Module Diagnostics page)

Number of Parking Light Flashes	Tach Error
3	No tach signal detected
4	System is in Valet mode
5	N/A
6	Tach set for 'assumed start'. No tach programming required

### Assumed Timed Crank - (Automatic Transmission Vehicles Only)

Assumed Time Crank is intended for vehicles with built-in anti-grind feature or vehicles that do not have a 12V Positive starter wire at the ignition harness. This option will send a crank signal to the vehicle for the length of time selected in menu option 1-2. This option can be used on vehicles with built in anti-grind systems or Push To Start (PTS) systems.

## System reset

A system reset will clear any programming performed in the vehicle including tach learn. Following a reset, the module will need to be programmed to the vehicle again, and you will need to complete the tach learn procedure. **SYSTEM RESET DOES NOT CLEAR ANY FIRMWARE PROGRAMMED TO THE MODULE, OR ALTER ANY SETTINGS IN THE OPTION MENUS. ANY FIRMWARE OR OPTION CHANGES REQUIRE YOU TO CONNECT TO THE WEB OR MOBILE USING A WEBLINK PROGRAMMER.**

>>



The following procedure resets the module programming to the vehicle. It does not reset any settings configured online.

01

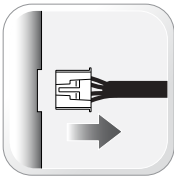

Disconnect all connectors from module except the M1 BLACK 8-pin connector and the M4 BLACK 20-pin connector.

02

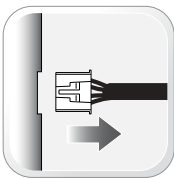

Disconnect the M1 BLACK 8-pin connector and the M4 BLACK 20-pin connector.

03



PRESS AND HOLD the module's programming button while connecting the M1 BLACK 8-pin connector and the M4 BLACK 20-pin connector.

04



Wait, LED 1 will flash RED. RELEASE programming button.

05

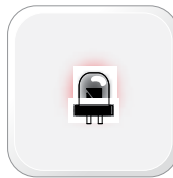

LED 1 will turn RED for 2 seconds.

06



Module RESET completed.

07

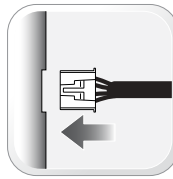

Reconnect all connectors.

08



Repeat programming procedure.

>>



Failure to follow procedure may result with a DTC or a CHECK ENGINE error message.

## Wiring Descriptions

---

### Connector M1, 8-Pin Black

Pin 1 **ORANGE** - Accessory 12V positive (+) output. This wire must be connected to the vehicle accessory / HVAC blower motor wire. The proper wire will test 0V with the key in the off position, (+) 12V while key is in the on position, 0V while cranking and back to (+) 12V when the key is returned to the on position.

Pin 2 **RED** - Constant 12V positive (+) power input. This wire must be connected as it provides power for the starter (PURPLE), Accessory (ORANGE), and the module's microprocessor. The proper wire will test (+) 12V at all times, even when the key is in the off position, on position, and during crank.

Pin 3 **PURPLE** - Starter 12V positive (+) output. This wire must be connected for remote start. The proper wire will test 0V with the key in the off position, 0V while the key is in the on position and (+) 12V during crank.

Pin 4 **PINK/WHITE (Programmable Output)** - Positive 12V (+) output that powers up during remote start. The default setting for this wire is (+) 2nd ignition. To change this setting, go to menu option 1-4

Pin 5 **PINK** - Ignition 12V positive (+) output and input. This wire must be connected to the vehicle's ignition for remote start and valet / remote programming. The proper wire will test 0V with the key in the off position, 12 V (+) while the key is in the on position and 12V (+) during crank.

Pin 6 **WHITE (Programmable Output)** - This positive (+) parking light wire triggers when you lock, unlock, remote start, or during troubleshooting diagnostics. To change this setting, go to menu option 1-5.

Pin 7 **RED** - Constant 12V positive (+) power input. This wire must be connected as it provides power for the ignition (PINK) and 2nd ignition (PINK/WHITE) outputs. The proper vehicle wire will test (+) 12V at all times - while the key is in the off position, the on position and during crank.

Pin 8 **BLACK** - Ground negative (-) input. This wire must be connected to the vehicle's chassis ground. Make sure no paint or rust is on the mounting surface. We recommend connecting this wire before the others.

## Connector M2, 12-Pin Black

Pin 1 **GREEN•BLACK DOT** - Lock 250mA (-) negative output: This is an output that will provide a (-) pulse for locking doors. System will lock doors and arm alarm.

Pin 2 **BLUE•BLACK DOT** - Unlock 250mA negative (-) output: This is an output that will provide a (-) pulse for unlocking doors. System will unlock doors and disarm alarm.

Pin 3 **RED/WHITE•BLACK DOT** - Trunk release 250mA negative (-) output: This is an optional output that will release the trunk. Use M1, Pin 4 if the vehicle is equipped with a (+) trunk release.

Pin 4 **GREEN/WHITE•BLACK DOT** - Factory Alarm Arm (FAA) 250mA negative (-) output: This is an optional output that will provide a (-) pulse during lock, after crank and again after the ignition shuts down. The FAA output can be configured using menu option 2-15

Pin 5 **GREEN/BLACK•BLACK DOT** - Factory Alarm Disarm (FAD) 250mA negative (-) output: This output will provide a (-) pulse during unlock and every time prior to the GWR (ground when running) turning on during the remote start sequence. It is typically used to disarm factory security systems.

Pin 6 **BLUE/WHITE•BLACK DOT** - Ground while running (GWR) 250mA negative (-) output: This is an optional output that will provide a negative (-) output 250mS before the ignition turns on, stays on throughout the remote start duration and will be the last to shut off.

Pin 7 **BROWN•BLACK DOT** - Siren: 1A (+) output can be connected to the positive lead of an aftermarket siren.

Pin 8 **WHITE/PURPLE•BLACK DOT** - (POC1) Programmable output. Default setting is 'Unlock other doors' 250mA negative (-) output. The output control is based on feature 5-01 option setting.  
**Note:** There are 21 additional POC setting options for this POC.

Pin 9 **PURPLE/BLACK•BLACK DOT** - (POC2) Programmable output. Default setting is 'RAP shutdown' 250mA negative (-) output. The output control is based on feature 5-02 option setting.  
**Note:** There are 21 additional POC setting options for this POC.

Pin 10 **WHITE/BLACK•BLACK DOT** - (POC3) Programmable output. Default setting is 'HORN' 250mA negative (-) output. The output control is based on feature 5-03 option setting.  
**Note:** There are 21 additional POC setting options for this POC.

Pin 11 **BROWN/BLACK•BLACK DOT** - (POC4) Programmable output. Default setting is 'Starter-Kill' 250mA negative (-) output. The output control is based on feature 5-04 option setting.  
**Note:** There are 21 additional POC setting options for this POC.

Pin 12 **WHITE•BLACK DOT** - Parking light 250mA negative (-) output. This will provide output whenever the parking lights are activated for lock, unlock, remote start, diagnostics, and programming. The proper wire in the vehicle will test (-) when the parking light switch is in the on.

### Connector M3, 10-Pin White

Pin 1 **BROWN•SILVER DOT** - Brake 12V positive (+) input: This wire must be connected as it provides a shut down for the remote start. It is also required for various programming options. The proper wire will test (+) 12V while the foot brake is pressed.

Pin 2 **BLACK/WHITE•SILVER DOT** - Parking / Emergency brake negative (-) input: This input is required for manual transmission/reservation and Turbo Timer mode. The proper e-brake wire will provide a (-) trigger when parking / emergency brake is set and the key is in the ignition or "on" position. This wire or input is required for manual transmission and turbo timer mode.

Pin 3 **PURPLE•SILVER DOT** - Door zone input (+). This wire monitors positive (+) trigger door-pins. The proper wire will provide a (+) trigger only when the doors are opened. You will need to test the wire for proper polarity. **IMPORTANT: A doorpin connection is required for manual transmission remote starts.**

Pin 4 **GREEN•SILVER DOT** - Door zone input (-). This wire monitors negative (-) trigger door-pins. The proper wire will provide a (-) trigger only when the doors are opened. You will need to test the wire for proper polarity. **IMPORTANT: A doorpin connection is required for manual transmission remote starts.**

Pin 5 **PURPLE/WHITE•SILVER DOT** - Engine sensing input (A/C): This wire is connected to the vehicle's Tach wire and is required when using the tach sense setting.

**IMPORTANT: To change engine-sensing modes, you must change Option 1-02; Default option is set for tach input.**

Pin 6 **WHITE/BLUE•SILVER DOT** - External RS trigger input (-) programmable input. This is an input (-) that can be used to activate the start sequence when triggered 1, 2, or 3 times based on option selected on feature 1-16. This can be done with a door lock motor output being operated by a factory keyless entry or another external source; Default option is 'disabled'.

Pin 7 **GRAY•SILVER DOT** - Hood Pin negative (-) input: This input is a safety shut down and alarm trigger. It prevents the vehicle from remote starting while the hood is open and triggers the alarm if the hood is opened while the alarm is armed. You can connect this wire to the hood pin supplied with this kit, or to a wire in the vehicle that shows (-) only while the hood is open.

Pin 8 **BLUE•SILVER DOT** - Trunk zone input (-): This is an optional input that will monitor when the vehicle's trunk has been opened. The proper wire will provide a (-) trigger while the trunk is open.

Pin 9 **GRAY/BLACK•SILVER DOT** - Glow plug input (+): Reads any positive input as a glow plug or wait to start input. This is recommended for diesel vehicles that may have a positive analog glow plug output available.

Pin 10 **TAN•SILVER DOT** - : External Alarm trigger input (-): This input will trigger the alarm with any negative (-) input while the system is armed. There are different options for the behavior of this input in menu 3-14.

**Connector M4, 20-Pin Black**

This connector is reserved for use with vehicle specific applications. If any connections to M4 are required, they will be indicated in the vehicle specific install diagram after flashing the FLRSBA.

**Connector M5, 6-Pin Blue**

This connector is reserved for use with vehicle specific applications. If any connections to M5 are required, they will be indicated in the vehicle specific install diagram after flashing the FLRSBA.

**Connector M6, 6-Pin Black**

This connector is reserved for use with vehicle specific applications. If any connections to M6 are required, they will be indicated in the vehicle specific install diagram after flashing the FLRSBA.

**Connector M7, 6-Pin Black**

Connect select Prestige or Pursuit antennas directly to the FLRSBA (requires proper RF selection during web programming. Follow the proper 'Remote Programming' instructions in this guide.

Pin 1 (B+) - Constant 5V positive (+) output

Pin 2 (RX) - Input, this wire receives data

Pin 3 (B-) - Ground (-) output

Pin 4 ( - ) - Button input

Pin 5 ( - ) - Output to LED

Pin 6 (TX) - Output, this wire transmits data

**Connector M8, 5-Pin Black**

Connect select Code Alarm antennas directly to the FLRSBA (requires proper RF selection during web programming. Follow the proper 'Remote Programming' instructions in this guide.

Pin 1 (B+) - Constant 12V positive (+) output

Pin 2 (RX/TX) - This wire send and receives data

Pin 3 (B-) - Ground (-) output

Pin 4 ( - ) - Button input

Pin 5 ( - ) - Output to LED

**Connector M9, 4-pin Red**

Connect select Code Alarm antennas directly to the FLRSBA (requires proper RF selection during web programming. Follow the proper 'Remote Programming' instructions in this guide.

Pin 1 (B+) - Constant 12V positive (+) output

Pin 2 (RX/TX) - This wire send and receives data

Pin 3 (B-) - Ground (-) output

Pin 4 ( - ) - Button input / Output to LED

**Connector M10, 4-Pin Black (Weblink)**

Used for programming and configuration of features and options. Connect the WEBLINK-USB programmer to interface with a compatible PC (not included). Also used to connect WEBLINK MOBILE RS programmers for Android or iOS (not included).

**Connector M11, 4-pin Blue (Carlink)**

Used for pairing with Carlink Telematic devices. Supported devices will appear during the flash/configuration procedure.

- Pin 1 (B+) - Constant 12V positive (+) output
- Pin 2 (B-) - Ground (-) output
- Pin 3 (RX) - Input, this wire receives data
- Pin 4 (TX) - Output, this wire transmits data

**Connector M12, 4-pin Yellow (BLE)**

This is an expansion port for adding optional accessories such as a Bluetooth receiver or MTDS Manual Transmission sensor.

- Pin 1 (B+) - Constant 12V positive (+) output
- Pin 2 (B-) - Ground (-) output
- Pin 3 (RX) - Input, this wire receives data
- Pin 4 (TX) - Output, this wire transmits data

**Connector M13, 4-pin White (Optional sensors)**

This is an expansion port for adding optional accessories such as a Bluetooth receiver or MTDS Manual Transmission sensor. Pin numbers are left to right.

- Pin 1 - (1st Shock) first stage shock (-) input
- Pin 2 - (2nd Shock) Second stage shock (-) input
- Pin 3 - (B-) Ground (-) output when armed
- Pin 4 - (B+) Constant 12V positive (+) output

**Automatic transmission loop, Black**

By default, the units come in MANUAL transmission mode. You will need to cut the black loop on the side of the control module if you are installing the unit in a AUTOMATIC transmission.

## Option Programming Tables

### Configured on the web or with Weblink Mobile RS

To access and configure options, you will need to be connected to the web using a Weblink USB interface or using the Weblink Mobile RS app for iOS or Android. The **BOLD** text marks the default settings for each menu item. See the 'OPTION MENU DESCRIPTIONS' section for a breakdown of each option.

<b>MENU 1 - Remote Starter</b>									
#	Feature	option 1	option 2	option 3	option 4	option 5	option 6	option 7	option 8
1-1	Engine/Wait to start	<b>Gas</b>	Diesel (Glow plug)	3 sec	5 sec	10 sec	15 sec	25 sec	45 sec
1-2	Engine sensing	<b>Tach</b>	N/A	assume start (2)	assume start (2.5)	assume start (3)	assume start (4)	assume start (5)	
1-3	Run time	3 min	5 min	10 min	<b>15 min</b>	25 min	30 min	35	
1-4	Programmable Relay 1 (4th relay)	<b>Ignition</b>	Accessories	Starter	Trunk	Parking Lights			
1-5	Programmable Relay 2 (5th relay)	Ignition	Accessories	Starter	Trunk	<b>Parking Lights</b>			
1-8	Weather mode	<b>Disable</b>	every 2 hour	every 3 hour	every 4 hour	with temp sensor			
1-9	Temp sensor for cold weather start	<b>Disable</b>	-20C/-4F	-15C/5F	-10C/14F	-5C/23F			
1-10	Temp sensor for hot weather start	<b>Disable</b>	25C/77F	30C/86F	35C/85F	40C/104F			
1-11	Idle mode	Disable	<b>Enable</b>						
1-12	Turbo timer	<b>Disable</b>	30 sec	1 min	2 min	4 min			
1-13	Take over behavior	<b>Enable</b>	Shutdown with Door	Shutdown with Unlock					
1-14	Secure take over delay	<b>45 sec</b>	90 sec	3 min	4 min				

## Option Programming Tables cont...

### Configured on the web or with Weblink Mobile RS

To access and configure options, you will need to be connected to the web using a Weblink USB interface or using the Weblink Mobile RS app for iOS or Android. The **BOLD** text marks the default settings for each menu item. See the 'OPTION MENU DESCRIPTIONS' section for a breakdown of each option.

MENU 1 - Remote Starter Continued									
#	Feature	option 1	option 2	option 3	option 4	option 5	option 6	option 7	option 8
1-15	Factory keyless RS sequence	Disable	Hold lock 3 sec (not always available)	Lock, Unlock, Lock	<b>Lock, Lock, Lock</b>				
1-16	External RS input trigger (X-trig input)	<b>Disable</b>	"single pulse (-)"	"double pulse (-)(-)"	"triple pulse (-)(-)(-)"	"Analog Factory Keyless X-Trigger = lock input Door(+) = unlock input"			
1-17	Valet mode	"Remote or 5 x ignition ON or 2 x ign. ON + 3 brake"	Remote or Antenna button only	"Remote or Antenna or 5 x ignition ON or 2 x ign. ON + 3 brake"	"Remote or 5 x ignition ON"	<b>"Antenna or Remote or 2 x ign. ON + 3 brake"</b>	"5 x ignition ON or 2 x ign. ON + 3 brake"	Antenna button only	"Antenna or 5 x ignition ON or 2 x ign. ON + 3 brake"
1-18	Heated ACC control	AUX trigger only	Always on	-10C/14F	-5C/24F	0C/32F	4C/40F	8C/46F	<b>12C/54F</b>
1-19	Cooled seats control	AUX trigger only	Always on	<b>20C/68F</b>	24C/76F	28C/82F	32C/90F	36C/96F	
1-20	RS Parking lights confirmation	Disable	<b>constant</b>	Flashing					
1-21	Crank time adjustment (tach)	<b>Disable</b>	+0.2 Second to crank	+0.6 Second to crank	-0.2 Second to crank				
1-22	Remote Starter	Disable	<b>Enable</b>						
1-23	Defrost Trigger	Aux trigger only	<b>Always on</b>	0C / 32F	-10/14F				
1-24	Defrost control	<b>1 sec</b>	5 min	10 min	15 min				
1-25	Shutdown on Trunk	<b>Disable</b>	Enable						

## Option Programming Tables cont...

### Configured on the web or with Weblink Mobile RS

To access and configure options, you will need to be connected to the web using a Weblink USB interface or using the Weblink Mobile RS app for iOS or Android. The **BOLD** text marks the default settings for each menu item. See the 'OPTION MENU DESCRIPTIONS' section for a breakdown of each option.

MENU 2 - Doorlocks									
#	Feature	Option 1	option 2	option 3	option 4	option 5	option 6	option 7	option 8
2-1	Doorlock analog output Duration	0.4 sec	<b>0.8 sec</b>	2 sec	4 sec				
2-2	Trunk analog output Duration	0.4 sec	<b>0.8 sec</b>	2 sec	4 sec				
2-3	Priority Unlock	<b>Disable</b>	Enable						
2-4	Double pulse Lock	<b>Disable</b>	Enable						
2-5	Double pulse unlock	<b>Disable</b>	Enable						
2-6	Auto re-lock	<b>Disable</b>	Enable						
2-7	Unlock before start	<b>Disable</b>	Enable						
2-8	Re-Lock after start	<b>Disable</b>	Enable	Smart re-lock					
2-9	Re-Lock after RS shutdown	<b>Disable</b>	Enable	Smart re-lock					
2-10	Lock after MT shutdown sequence	<b>Disable</b>	Enable	Smart re-lock					
2-11	Lock after turbo mode	<b>Disable</b>	Enable						
2-12	Ignition controlled doorlock	<b>Disable</b>	Enable	Enable 2000 RPM					
2-13	Ignition controlled doorlock setting	<b>Lock + unlock</b>	Lock only	Unlock only					
2-14	Trunk sequence	<b>Disarm, unlock and trunk</b>	disarm and trunk	trunk only	Disarm, unlock all and trunk				

## Option Programming Tables cont...

### Configured on the web or with Weblink Mobile RS

To access and configure options, you will need to be connected to the web using a Weblink USB interface or using the Weblink Mobile RS app for iOS or Android. The **BOLD** text marks the default settings for each menu item. See the 'OPTION MENU DESCRIPTIONS' section for a breakdown of each option.

MENU 2 - Doorlocks Continued									
#	Feature	option 1	option 2	option 3	option 4	option 5	option 6	option 7	option 8
2-15	Analog Rearm Trigger	after start, shutdown and first lock	<b>after shut down and first lock</b>	after start only	after shut-down only				
2-16	Analog Disarm Sequence	<b>Disarm only</b>	Disarm with Ign cycle						
2-17	DL Parking lights confirmation	Disable	<b>Enable</b>	Enable with Ignition Only	Enable without ignition				
2-18	Headlight output (POC)	<b>Lock and Unlock</b>	Lock only	Unlock only					

## Option Programming Tables cont...

### Configured on the web or with Weblink Mobile RS

To access and configure options, you will need to be connected to the web using a Weblink USB interface or using the Weblink Mobile RS app for iOS or Android. The **BOLD** text marks the default settings for each menu item. See the 'OPTION MENU DESCRIPTIONS' section for a breakdown of each option.

MENU 3 - Security									
#	Feature	option 1	option 2	option 3	option 4	option 5	option 6	option 7	option 8
3-1	Alarm	<b>Disable</b>	Enable						
3-2	Alarm duration	30 sec	<b>60 sec</b>	120 sec					
3-3	Alarm Triggered behavior	<b>No Delay</b>	Delay with parking lights	Delay with parking lights and chirps					
3-4	Passive alarm/locks	<b>Active only</b>	Alarm & Locks	Alarm only	Locks only				
3-5	Passive alarm/ auto-relock notification	<b>Disable</b>	Alarm & Locks	Alarm only	Locks only				
3-6	Passive alarm/ auto-relock timing	<b>30 sec</b>	60 sec	5 min	10 min				
3-7	Passive open zone bypass (Force rearm)	<b>Disable</b>	Enable						
3-8	Open zone notification	Disable	<b>Enable</b>	15 sec delay	20 sec delay	25 sec delay	30 sec delay	35 sec delay	
3-9	Confirmation chirp (Horn Output)	Disable	Lock only	<b>Double lock only</b>	Lock and unlock	unlock only	Lock, Unlock, Start	Double Lock, Start	
3-10	Confirmation chirp (Siren Output)	Disable	Lock only	Double lock only	<b>Lock and unlock</b>	unlock only	Lock, Unlock, Start	Double Lock, Start	
3-11	Siren notification from OEM keyless	Disable	<b>Enable</b>						
3-12	Horn chirp pulse duration	20 ms	<b>30 ms</b>	40 ms	45 ms	50 ms	60 ms	100 ms	
3-13	Shock Sensor input behavior	Disable	<b>Enable</b>	Warn away only	Shock only				
3-14	Analog sensor (-) input behavior	<b>Disable</b>	Warn away only (-)	Shock(-)	Normally Closed Alarm(+)	Zone 2 passive 15(-)	Zone 2 passive 30(-)		

## Option Programming Tables cont...

### Configured on the web or with Weblink Mobile RS

To access and configure options, you will need to be connected to the web using a Weblink USB interface or using the Weblink Mobile RS app for iOS or Android. The **BOLD** text marks the default settings for each menu item. See the 'OPTION MENU DESCRIPTIONS' section for a breakdown of each option.

MENU 3 - Security Continued									
#	Feature	option 1	option 2	option 3	option 4	option 5	option 6	option 7	option 8
3-15	Alarm control from OEM keyless	Disable	<b>Enable with no-tification on after-market remotes</b>	Enable without notification on aftermarket remotes					
3-16	LED flashing	Disable	<b>Follow alarm status</b>						
3-17	alarm/panic with Parking lights	Disable	<b>Enable</b>						
3-18	Car finder duration	<b>5 sec</b>	10 sec	15 sec	60 sec				
3-19	Starter kill/anti-grind	<b>Anti-grind + active SK</b>	Anti-grind only	Anti-grind + passive SK 30 seconds	Anti-grind + passive SK 60 seconds				
3-20	Alarm event on remote	Disable	<b>Enable</b>						
3-21	Alarm first disarm behavior	<b>Disarm, Unlock, Silence</b>	Silence only						
3-22	Alarm and keyless override option	Custom code option	<b>Valet switch</b>						
3-23	Real Panic Sound (Random pulse length)	Disable	<b>Enable</b>						
3-24	Siren Chirp pulse duration	20 ms	<b>30 ms</b>	40 ms	45 ms	50 ms	60 ms	100 ms	

## Option Programming Tables cont...

### Configured on the web or with Weblink Mobile RS

To access and configure options, you will need to be connected to the web using a Weblink USB interface or using the Weblink Mobile RS app for iOS or Android. The **BOLD** text marks the default settings for each menu item. See the 'OPTION MENU DESCRIPTIONS' section for a breakdown of each option.

<b>MENU 4 - AUX function assignment</b>									
#	Feature	option 1	option 2	option 3	option 4	option 5	option 6	option 7	option 8
4-1	Transmitter AUX 1	Left slide door	<b>Right slide door</b>	PTO 1	PTO 2	PTO 3	PTO 4	Car Finder	Gas cap
4-2	Transmitter AUX 2	<b>Left slide door</b>	Right slide door	PTO 1	PTO 2	PTO 3	PTO 4	Car Finder	Gas cap
4-3	Transmitter AUX 3	Left slide door	Right slide door	<b>PTO 1</b>	PTO 2	PTO 3	PTO 4	Car Finder	Gas cap
4-4	Transmitter AUX 4	Left slide door	Right slide door	PTO 1	<b>PTO 2</b>	PTO 3	PTO 4	Car Finder	Gas cap
4-5	Transmitter AUX 5	Left slide door	Right slide door	PTO 1	PTO 2	PTO 3	PTO 4	<b>Car Finder</b>	Gas cap
4-6	Secure Auxiliaries	<b>Disable</b>	Enable	Enable while armed					
<b>MENU 4 - AUX function assignment continued</b>									
#	Feature	option 9	option 10	option11	option 12	option13			
4-1	Transmitter AUX 1	Rear glass	Heated Seats	Cooled Seats	Panic	Defrost			
4-2	Transmitter AUX 2	Rear glass	Heated Seats	Cooled Seats	Panic	Defrost			
4-3	Transmitter AUX 3	Rear glass	Heated Seats	Cooled Seats	Panic	Defrost			
4-4	Transmitter AUX 4	Rear glass	Heated Seats	Cooled Seats	Panic	Defrost			
4-5	Transmitter AUX 5	Rear glass	Heated Seats	Cooled Seats	Panic	Defrost			

## Option Programming Tables cont...

### Configured on the web or with Weblink Mobile RS

To access and configure options, you will need to be connected to the web using a Weblink USB interface or using the Weblink Mobile RS app for iOS or Android. The **BOLD** text marks the default settings for each menu item. See the 'OPTION MENU DESCRIPTIONS' section for a breakdown of each option.

MENU 5 - Programmable outputs (POC)									
#	Feature	option 1	option 2	option 3	option 4	option 5	option 6	option 7	option 8
5-1	POC 1	<b>Unlock Others</b>	Defrost	Horn	IGN	ACC	Start	Parking Lights	Pulse Timer Output 1
5-2	POC 2	Unlock Others	Defrost	Horn	IGN	ACC	Start	Parking Lights	Pulse Timer Output 2
5-3	POC 3	Unlock Others	Defrost	<b>Horn</b>	IGN	ACC	Start	Parking Lights	Pulse Timer Output 3
5-4	POC 4	<b>Starter kill</b>	Defrost	Horn	IGN	ACC	Start	Parking Lights	Pulse Timer Output 4
MENU 5 - Programmable outputs (POC) continued									
#	Feature	option 9	option 10	option 11	option 12	option 13	option 14	option 15	option 16
5-1	POC 1	PTO1	PTO2	PTO3	PTO4	Future use	Arm	Disarm	Lock
5-2	POC 2	PTO1	PTO2	PTO3	PTO4	Future use	Arm	Disarm	Lock
5-3	POC 3	PTO1	PTO2	PTO3	PTO4	Future use	Arm	Disarm	Lock
5-4	POC 4	PTO1	PTO2	PTO3	PTO4	Future use	Arm	Disarm	Lock
MENU 5 - Programmable outputs (POC) continued									
#	Feature	option 17	option 18	option 19	option 20	option 21	option 22	option 23	option 24
5-1	POC 1	Unlock	Trunk	GWR	Left sliding door	Right sliding door	<b>Rap Shut-down</b>	Siren	GND when Engine ON
5-2	POC 2	Unlock	Trunk	GWR	Left sliding door	Right sliding door	Rap Shut-down	Siren	GND when Engine ON
5-3	POC 3	Unlock	Trunk	GWR	Left sliding door	Right sliding door	Rap Shut-down	Siren	GND when Engine ON
5-4	POC 4	Unlock	Trunk	GWR	Left sliding door	Right sliding door	Rap Shut-down	Siren	GND when Engine ON
MENU 5 - Programmable outputs (POC) continued									
#	Feature	option 25	option 26	option 27	option 28				
5-1	POC 1	Ground when disarm	Domelight	GND Headlight output	RS/Alarm LED				
5-2	POC 2	Ground when disarm	Domelight	GND Headlight output	RS/Alarm LED				
5-3	POC 3	Ground when disarm	Domelight	GND Headlight output	RS/Alarm LED				
5-4	POC 4	Ground when disarm	Domelight	GND Headlight output	RS/Alarm LED				

## Option Programming Tables cont...

### Configured on the web or with Weblink Mobile RS

To access and configure options, you will need to be connected to the web using a Weblink USB interface or using the Weblink Mobile RS app for iOS or Android. The **BOLD** text marks the default settings for each menu item. See the 'OPTION MENU DESCRIPTIONS' section for a breakdown of each option.

MENU 6 - Pulse timer output configurations (PTO)									
#	Feature	option 1	option 2	option 3	option 4	option 5	option 6	option 7	option 8
6-1	PTO 1 duration	<b>1 second pulse</b>	latched 10 sec	latched 15 sec	latched 20 sec	latched 30 sec	latched 5 min	latched 10 min	Run time latch
6-2	PTO 2 duration	<b>1 second pulse</b>	latched 10 sec	latched 15 sec	latched 20 sec	latched 30 sec	latched 5 min	latched 10 min	Run time latch
6-3	PTO 3 duration	<b>1 second pulse</b>	latched 10 sec	latched 15 sec	latched 20 sec	latched 30 sec	latched 5 min	latched 10 min	Run time latch
6-4	PTO 4 duration	<b>1 second pulse</b>	latched 10 sec	latched 15 sec	latched 20 sec	latched 30 sec	latched 5 min	latched 10 min	Run time latch

MENU 7 - Input source configurations									
#	Feature	option 1	option 2	option 3	option 4	option 5	option 6	option 7	option 8
7-1	Brake	Analog	Data	<b>AUTO</b>					
7-2	Door	Analog	Data	<b>AUTO</b>					
7-3	Tach	Analog	Data	<b>AUTO</b>					
7-4	Hood	Analog	Data	<b>AUTO</b>	Analog Inv.				
7-5	Trunk	Analog	Data	<b>AUTO</b>					
7-6	Glow plug	Analog	Data	<b>AUTO</b>					
7-7	E-brake	Analog	Data	<b>AUTO</b>					
7-8	Thermistor/temp sensor	Analog	Data	<b>AUTO</b>					
7-9	VSS	Disable	<b>Data (Auto)</b>						
7-10	T-Harness firmware support	Disable	Enable	<b>AUTO</b>					
7-11	Digital shock sensor	Disable	<b>Internal</b>	N/A	MTDS				
7-12	Digital tilt sensor	Disable	<b>Internal</b>	N/A	MTDS				
7-20	Temperature sensor adjustment	Select value on weblink/Diagnostic tool : (-15 to 15 deg C), Default 0 Deg.C							
7-21	Digital shock sensor trigger adjustment	Select value on weblink/Diagnostic tool : (0.5-10), Default 1 (less sensitive). 0 = OFF, 0.5 = min, 10 = max.							
7-22	Digital shock sensor warn away adjustment	Select value on weblink/Diagnostic tool : (0.5-10), Default 1 (less sensitive). 0 = OFF, 0.5 = min, 10 = max.							
7-23	Digital tilt adjustment	Select value on weblink/Diagnostic tool : (OFF, 1.0 to 4.0 deg), Default 2.5 Deg							

## Option Programming Tables cont...

### Configured on the web or with Weblink Mobile RS

To access and configure options, you will need to be connected to the web using a Weblink USB interface or using the Weblink Mobile RS app for iOS or Android. The **BOLD** text marks the default settings for each menu item. See the 'OPTION MENU DESCRIPTIONS' section for a breakdown of each option.

MENU 8 - Output source configurations									
#	Feature	option 1	option 2	option 3	option 4	option 5	option 6	option 7	option 8
8-1	Arm	Analog	<b>Analog/Data</b>						
8-2	Disarm	Analog	<b>Analog/Data</b>						
8-3	Lock	Analog	<b>Analog/Data</b>						
8-4	Unlock all	Analog	<b>Analog/Data</b>						
8-5	Unlock driver door	Analog	<b>Analog/Data</b>						
8-6	Trunk	Analog	<b>Analog/Data</b>						
8-7	Left sliding door	Analog	<b>Analog/Data</b>						
8-8	Right sliding door	Analog	<b>Analog/Data</b>						
8-9	Parking lights	Analog	<b>Analog/Data</b>						
8-10	Rap shut down	Analog	<b>Analog/Data</b>						
8-11	Panic and alarm	Analog	<b>Analog/Data</b>						
8-12	Car finder	Analog	<b>Analog/Data</b>						
8-13	Defrost	Analog	<b>Analog/Data</b>						
8-14	Horn chirp (notification)	Analog	<b>Analog/Data</b>						
8-15	Sleep status on LED	<b>Disable</b>	Enable						
8-16	Siren chirp (notification)	Analog	<b>Analog/Data</b>						

## Option Menu Descriptions

### **FO = Default Feature Option**

1-01 Engine type: Every FLRSBA is shipped in manual transmission mode. Tach sensing is our default engine sense option.

**FO1 - Gas:** Suitable for all gas powered vehicles. This option relies on the input specified in 1-02.

**FO2 - Diesel (with glow plug signal):** This option uses the hardwired glow plug input (gray/black M3 white connector) to read the (+) glow plug status from the vehicle. This is usually connected to the signal going to the light in the dash. Once the light goes out and the signal is lost, the vehicle will crank. This option relies on the input specified in 1-02.

**FO3 to FO8 - Wait to start delay:** Any of these settings will force the remote starter to wait (with ignition on) for the selected time before cranking the engine. Determine the maximum time required to insure the vehicle's gloplug are ready, and set the delay accordingly. This option relies on the input specified in 1-02.

1-02 Engine tach detection: Method used to determine when we need to release start signal.

**FO1 - Tach input/data:** This option uses a hard wired input (purple/white on the M3 white connector) to read the vehicles RPM's in order to release the starter during the remote start process and determine that the engine is running. In some vehicle specific solutions, this signal may be obtained through the vehicle's databus (no connection required).

**FO3 to FO7 - Assumed start (for hybrid):** The vehicle will crank for the time specified by your selection. The remote starter will then 'run' for the selected runtime. It does not require a connection to the vehicle other than the main ignition harness.

1-03 Runtime: This feature consists of four different settings for the remote start run time.

**FO1 - Runtime of 3min:** The remote starter will run for a period of 3 minutes.

**FO2 - Runtime of 5min:** The remote starter will run for a period of 5 minutes.

**FO3 - Runtime of 10min:** The remote starter will run for a period of 10 minutes.

**FO4 - Runtime of 15min:** The remote starter will run for a period of 15 minutes.

**FO5 - Runtime of 25min:** The remote starter will run for a period of 25 minutes.

**FO6 - Runtime of 30min:** The remote starter will run for a period of 30 minutes.

**FO7 - Runtime of 35min:** The remote starter will run for a period of 35 minutes.

## Option Menu Descriptions cont...

### **FO = Default Feature Option**

1-04 Programmable high power relay #4 (M1 - Pink/White): Controls the function of this wire.

**FO1 - Ignition:** Follows the behavior of the primary (+) Ignition wire.

**FO2 - Accessory:** Follows the behavior of the primary (+) Accessory wire.

**FO3 - Starter:** Follows the behavior of the primary (+) Starter wire.

**FO4 - Trunk:** Provides a high-current (+) output for trunk release.

**FO5 - Parking Lights:** Provides a high-current (+) output for parking lights.

1-05 Programmable high power relay #5 (M1 - White): Controls the function of this wire.

**FO1 - Ignition:** Follows the behavior of the primary (+) Ignition wire.

**FO2 - Accessory:** Follows the behavior of the primary (+) Accessory wire.

**FO3 - Starter:** Follows the behavior of the primary (+) Starter wire.

**FO4 - Trunk:** Provides a high-current (+) output for trunk release.

**FO5 - Parking Lights:** Provides a high-current (+) output for parking lights.

1-08 Weather mode: This feature is designed to allow the user to have the FLRSBA automatically remote start at the end of a selected timed cycle. It also be controlled by the thermistor so it will start at a specified temperature at the end of the timed cycle. Weather mode must also be activated each time between vehicle uses. *Weather mode is cancelled automatically after 24 hours or if the vehicle is started by key or RS.*

**FO1 - Disable:** Weather mode is disabled.

**FO2 - Every 2 hours:** Will activate every 2 hours and run for the programmed runtime.

**FO3 - Every 3 hours:** Will activate every 3 hours and run for the programmed runtime.

**FO4 - Every 4 hours:** Will activate every 4 hours and run for the programmed runtime.

**FO5 - With temp sensor:** Will activate based on the selected temp settings in menu 1-09, 1-10 and run for the programmed runtime.

1-09 Temperature option for cold weather start: Use this option to set the temperature to automatically start the vehicle in cold weather. This option uses the internal temperature sensor, or an external sensor if one is connected. *Requires that menu option 1-08 be set for 'Enable with temp sensor'.* Weather mode must also be activated each time between vehicle uses. *Weather mode is cancelled automatically after 24 hours or if the vehicle is started by key or RS.*

**FO1 - Disable**

**FO2 - Below -20C / -4F**

**FO3 - Below -15C / 5F**

**FO4 - Below -10C / 14F**

**FO5 - Below -5C / 23F**

## Option Menu Descriptions cont...

### **FO = Default Feature Option**

1-10 Temperature option for hot weather start: Use this option to set the temperature to automatically start the vehicle in hot weather. This option uses the internal temperature sensor, or an external sensor if one is connected. *Requires that menu option 1-08 be set for 'Enable with temp sensor'.* Weather mode must also be activated each time between vehicle uses. *Weather mode is cancelled automatically after 24 hours or if the vehicle is started by key or RS.*

**FO1 - Disable**

**FO2 - Above 26C / 77F**

**FO3 - Above 30C / 86F**

**FO4 - Above 35C / 95F**

**FO5 - Above 40C / 104F**

1-11 Idle mode (also known as pit stop mode): Allows the remote starter to be activated while the vehicle is running under key. When activated, the user can exit the vehicle with the key or fob and the vehicle will continue to run for the programmed runtime. NOTE: This option is not available on all vehicles.

**FO1 - Disable**

**FO2 - Enable**

1-12 Turbo Timer: (This feature requires door and e-brake input) This feature allows the user to activate Turbo Timer Mode with their Voxx remote or accessory. This will keep the engine running after removing the key for the specified time selected below. (Please check specific remote or accessory user's manual for steps to activate Turbo Timer Mode).

**FO1 - Disable:** Weather mode is disabled.

**FO2 - Enable for 30sec:** Vehicle with continue to run for 30 seconds.

**FO3 - Enable for 1min:** Vehicle with continue to run for 1 minute.

**FO4 - Enable for 2min:** Vehicle with continue to run for 2 minutes.

**FO5 - Enable for 4min:** Vehicle with continue to run for 4 minutes.

1-13 Takeover: Controls what happens when the user enters the vehicle which is running under remote start. NOTE Not all options are available for all vehicles.

**FO1 - Enable:** Vehicle will stay running as the user takes control of the vehicle during remote start.

**FO2 - Disable and shut down on door open:** Vehicle will shutdown as soon as a door is opened. Vehicle must be restarted manually.

**FO3 - Disable and shutdown on unlock:** Vehicle will shutdown as soon as an unlock command is received. Vehicle must be restarted manually.

## Option Menu Descriptions cont...

### **FO = Default Feature Option**

1-14 Secure take over delay: This feature only applies to specific PTS vehicle solutions. Consult the vehicle specific info on our website. This menu controls the amount of time the user has to complete takeover once they have entered a remote started vehicle. If the user has not completed all the steps for takeover in the given time, the process will be cancelled and the vehicle will shut down when the brake is pressed.

**FO1 - Timeout of 45 seconds**

**FO2 - Timeout of 1.5 minutes**

**FO3 - Timeout of 3 minutes**

**FO4 - Timeout of 4 minutes**

1-15 Factory keyless remote start activation: Allows the remote starter to be engaged using the vehicles OEM remote or keyfob. NOTE: This feature is not available on all vehicles. Consult our website for more information.

**FO1 - Disable**

**FO2 - Hold Lock 3 sec:** Activates remote start 3sec hold on Lock from OEM remote. (Not available with all firmware).

**FO3 - Lock, Unlock, Lock:** Activates remote start when a sequence of lock/unlock/lock is received from the OEM remote.

**FO4 - Lock, Lock, Lock:** Activates remote start when a sequence of lock/lock/lock is received from the OEM remote.

1-16 External RS trigger input: Allows the remote starter to be triggered using an external negative signal connected to M3-06 WHITE/BLUE. Choose from these different options to control how this input works;

**FO1 - Disable:** Input is disabled

**FO2 - Single pulse:** A single pulse to the wire will activate remote start.

**FO3 - Double pulse:** A double pulse to the wire will activate remote start.

**FO4 - Triple pulse:** A triple pulse to the wire will activate remote start.

**FO5 - Analog factory keyless (lock input):** This option is only required if you are setting menu option 1-15 for option F02 (lock/unlock/lock). M3-06 will act as a (-) lock input. Use M3-03 PURPLE/silver dot as a (+) unlock input.

1-17 Valet: In Valet mode, the remote starter and alarm(if activated) are disabled. Only keyless entry is functional. This option is used when an emergency disarm is required (lost remote) or the vehicle is brought in for service. NOTE: For a comprehensive explanation of each option, see the VALET section of this guide.

**FO1 - Remote / 5x Ignition / 2x Ignition+3x Brake**

**FO2 - Remote / Antenna**

**FO3 - Remote / Antenna / 5x Ignition / 2x Ignition+3x Brake**

**FO4 - Remote / 5x Ignition**

**FO5 - Remote / Antenna / 2x Ignition+3x Brake**

**FO6 - 5x Ignition / 2x Ignition+3x Brake**

**FO7 - Antenna button only**

**FO8 - Remote / Antenna / 5x Ignition / 2x Ignition+3x Brake**

## Option Menu Descriptions cont...

### **FO = Default Feature Option**

1-18 Heated accessory control: This feature controls the activation of heated accessories. This option is NOT associated with an analog output, and is available only when a vehicle specific firmware supports it. For an analog output to control defrost or heated seats, use menu options 1-23 and 1-24 in conjunction with an POC output set for 'Defrost'.

**FO1 - Aux trigger only:** Will only activate when an auxiliary programmed to 'heated seats' is activated.

**FO2 - Always on:** Activates on each remote start.

**FO3 - Activate at -10C/14F:** Activates at the preset temperature.

**FO4 - Activate at -5C/24F:** Activates at the preset temperature.

**FO5 - Activate at 0C/32F:** Activates at the preset temperature.

**FO6 - Activate at 4C/40F:** Activates at the preset temperature.

**FO7 - Activate at 8C/46F:** Activates at the preset temperature.

**FO8 - Activate at 12C/54F:** Activates at the preset temperature.

1-19 Cooled seats control: This feature controls the activation of cooled seats feature. This option is NOT associated with an analog output, and is available only when a vehicle specific firmware supports it. For an analog output to control this type of feature, use menu options 1-23 and 1-24 in conjunction with an POC output set for 'Defrost'.

**FO1 - Aux trigger only:** Will only activate for an auxiliary programmed to 'cooled seats' is activated.

**FO2 - Always on:** Activates on each remote start.

**FO3 - Activate at 20C/68F:** Activates at the preset temperature.

**FO4 - Activate at 24C/76F:** Activates at the preset temperature.

**FO5 - Activate at 28C/82F:** Activates at the preset temperature.

**FO6 - Activate at 32C/90F:** Activates at the preset temperature.

**FO7 - Activate at 36C/96F:** Activates at the preset temperature.

1-20 Parking light confirmation: Controls the behavior of the parking lights feature during remote start.

**FO1 - Disable:** All parking light outputs are disabled during remote start.

**FO2 - Constant ON:** Parklights will output steady the entire duration of runtime.

**FO3 - Flashing:** Parklights will flash once every 5 seconds for the duration of the runtime.

1-21 Crank time adjustment: Allows fine adjustments to the default crank time for remote start. *NOTE: Only use this feature to correct start issues related to crank time.*

**FO1 - Disable:** The remote starter will crank for the default crank time.

**FO2 - Add 200ms to crank:** The remote starter will crank for 200ms longer than the default.

**FO3 - Add 600ms to crank:** The remote starter will crank for 200ms longer than the default.

**FO4 - Subtract 200ms from crank:** The remote starter will crank for 200ms less than the default.

## Option Menu Descriptions cont...

### **FO = Default Feature Option**

1-22 Remote Starter: This feature turns the remote starter function on/off.

**FO1 - Disable**

**FO2 - Enable**

1-23 Defrost trigger: This option controls the activation of the defrost feature. A POC must be programmed associated with an analog output (menu 5). The duration of the output is controlled in menu 1-24.

**FO1 - Aux trigger only:** Activates only when an aux is activated. Requires you to configure an aux for one of the POC's in menu 4.

**FO2 - Always on:** Activates automatically on remote start. A POC must be programmed associated with an analog output (menu 5)

**FO3 - Activate at 0C/32F:** Activates at the preset temperature. A POC must be programmed associated with an analog output (menu 5)

**FO4 - Activate at -10C/14F:** Activates at the preset temperature. A POC must be programmed associated with an analog output (menu 5)

1-24 Defrost control: Controls the duration of the defrost output when engaged. A POC must be programmed associated with an analog output (menu 5)

**FO1 - 1 second:** Output will pulse for 1 second upon activation based on setting in menu 1-23.

**FO2 - 5 minutes:** Output will latch for 5 min. upon activation based on setting in menu 1-23.

**FO3 - 10 minutes:** Output will latch for 10 min. upon activation based on setting in menu 1-23.

**FO4 - 15 minutes:** Output will latch for 15 min. upon activation based on setting in menu 1-23.

1-25 Shutdown on trunk: Controls if the remote starter shuts down when the trunk is opened during runtime.

**FO1 - Disable**

**FO2 - Enable**

## Option Menu Descriptions cont...

### **FO = Default Feature Option**

**2-1 Lock & Unlock analog pulse length:** This does not affect the behavior of the factory arm output (green/white/silver dot) or factory alarm disarm output (green/black/silver dot) wires.

**FO1 - 0.4 seconds:** (-) Negative lock and unlock output time. This option may be helpful when using lock/unlock to arm/disarm vehicles that may roll windows down with factory Arm/Disarm wires when the standard output is too long.

**FO2 - 0.8 seconds:** (-) Negative lock and unlock output time.

**FO3 - 2 seconds:** (-) Negative lock and unlock output time.

**FO4 - 4 seconds:** (-) Negative lock and unlock output time.

**2-2 Trunk analog pulse length:** Controls the length of the analog trunk release output.

**FO1 - 0.4 seconds:** Trunk release output time.

**FO2 - 0.8 seconds:** Trunk release output time.

**FO3 - 2 seconds:** Trunk release output time.

**FO4 - 4 seconds:** Trunk release output time.

**2-3 Priority unlock:** When enabled, provides a dual stage unlock for driver's door priority. For analog doorlocks you must program a POC for 'Unlock others' in menu 5. For vehicle specific firmware solutions, this option may not be available.

**FO1 - Disable**

**FO2 - Enable**

**2-4 Double pulse lock:** This option will provide a double pulse when the lock command is executed by the CM. The length of output time will be determined by menu option 2-1

**FO1 - Disable**

**FO2 - Enable**

**2-5 Double pulse unlock:** This option will provide a double pulse when the unlock command is executed by the CM. The length of output time will be determined by menu option 2-1

**FO1 - Disable**

**FO2 - Enable**

**2-6 Auto relock:** This option will relock the doors 30 seconds after they have been unlocked by the CM, if no doors have been opened. The length of output time will be determined by menu option 2-1

**FO1 - Disable**

**FO2 - Enable**

**FO = Default Feature Option**

2-7 Unlock before remote start: Sends an unlock command when the remote start sequence is triggered.

**FO1 - Disable**

**FO2 - Enable**

2-8 Re-lock after start: Sends a lock command as soon as the CM has confirmed remote start success.

**FO1 - Disable**

**FO2 - Enable**

**FO3 - Enable with smart re-lock:** Doors will only re-lock if they were locked by the CM before remote start.

2-9 Re-lock after remote start shutdown: Sends a lock command after the remote start shuts down.

**FO1 - Disable**

**FO2 - Enable**

**FO3 - Enable with smart re-lock:** Doors will only re-lock if they were NOT unlocked by the CM during remote start.

2-10 Lock after manual transmission shutdown sequence: Upon successful completion of reservation mode (vehicle shuts down), the CM will send a lock command.

**FO1 - Disable**

**FO2 - Enable**

**FO3 - Enable with smart re-lock:** Doors will only re-lock if they were NOT unlocked by the CM during the reservation sequence.

2-11 Lock after turbo timer shutdown: If Turbo mode is engaged in menu 1-12, the CM will send a lock command after the vehicle shuts down.

**FO1 - Disable**

**FO2 - Enable**

2-12 Ignition controlled doorlock: This option will provide a door lock output when the vehicle's ignition is turned on by the user, or once the vehicle's RPM reaches a pre-determined value while driving. This setting also depends on menu option 2-13.

**FO1 - Disable**

**FO2 - Enable**

**FO3 - Enable at 2000 RPM (only is tach input is selected in menu 1-2)**

2-13 Ignition controlled doorlock setting: Determines if the ignition on/off controls lock, unlock, or both. For lock, the CM will provide a door lock output when the vehicle's ignition is turned on. For unlock, CM will provide a door unlock output as soon as the key is turned off or 12v ignition is removed.

**FO1 - Lock & Unlock**

**FO2 - Lock only**

**FO3 - Unlock only**

## Option Menu Descriptions cont...

### **FO = Default Feature Option**

2-14 Trunk activation sequence: Controls what occurs when a trunk release command is sent to the CM.

**FO1 - Disarm, then unlock, then trunk release**

**FO2 - Disarm, then trunk release**

**FO3 - Trunk release only**

**FO4 - Disarm, then unlock all, then trunk release**

2-15 Analog rearm trigger output: Sets the behavior for the analog arm wire (M2-04 GREEN/WHITE/BLACK DOT).

**FO1 - After start & after shutdown & on first lock press**

**FO2 - After shutdown & on first lock press**

**FO3 - After start only**

**FO4 - After shutdown only**

2-16 Analog disarm sequence: Controls how disarm occurs when the CM receives an unlock command or remote start command.

**FO1 - Disarm only:** The CM will send an pulse output to the analog disarm (M2-05 GREEN/BLACK/BLACK DOT).

**FO2 - Disarm with ignition cycle:** The CM will send an pulse output to the analog disarm (M2-05 GREEN/BLACK/BLACK DOT) AND pulse the ignition (+) output wire simultaneously.

2-17 Doorlock parking lights confirmation : Controls the behavior of the parking light output as doolock commands are executed. These settings are generally reserved for vehicle specific applications and will be set by the firmware. For general purposes, the default is always 'enable'

**FO1 - Disable**

**FO2 - Enable**

**FO3 - Enable with ignition ON only**

**FO4 - Enable with ignition OFF only**

2-18 Headlight output: This feature can serve to turn on the headlights for courtesy illumination when the keyless entry is used. This option works in conjunction with a POC programmed as 'GND headlight output' in menu 5

**FO1 - Lock and unlock**

**FO2 - Lock only**

**FO3 - Unlock only**

## Option Menu Descriptions cont...

### **FO = Default Feature Option**

3-1 Alarm: Activates or deactivates the ALARM features of the FLRSBA.

**FO1 - Disable**

**FO2 - Enable**

3-2 Alarm duration: Sets the length of time the alarm will sound if triggered.

**FO1 - 30 seconds**

**FO2 - 60 seconds**

**FO3 - 120 seconds**

3-3 Alarm triggered behavior: Controls the delay between an alarm infraction and the system triggering the lights/horn/siren.

**FO1 - Alarm will sound right after the trigger:** The alarm system will activate lights and siren/horn instantly when a trigger is detected.

**FO2 - Delay with parking lights, then alarm:** When the alarm is triggered, the CM will flash the parking lights for 5 seconds before sounding the alarm.

**FO3 - Delay with parking lights and chirps, then alarm:** When the alarm is triggered, the CM will chirp the siren and flash the parking lights for 5 seconds before sounding the alarm.

3-4 Passive alarm / Passive lock : This feature is used to control automatic (passive) arming or locking of the system. When ignition is turned off, and a door is opened then closed, it will activate the passive delay. If activated, the timing for this feature is controlled in menu option 3-6

**FO1 - Off:** Only commands from the user will arm and/or lock the system.

**FO2 - Passive arming with passive locking:** The alarm will arm and the doors will lock automatically based on the timing in menu option 3-6.

**FO3 - Passive arming only:** The alarm will arm automatically based on the timing in menu option 3-6. The doors will NOT lock.

**FO4 - Passive locking only:** The doors will lock automatically based on the timing in menu option 3-6. The alarm will NOT arm.

3-5 Passive alarm and/or doorlock notification : When alarm or doorlocks are set for passive arming, you can control the notifications that occur.

**FO1 - Disable**

**FO2 - Notification of passive arming & locking:** The siren/horn will chirp when the system locks the doors and arms the alarm passively.

**FO3 - Notification of passive arming only:** The siren/horn will chirp only when the system arms passively.

**FO4 - Notification of passive locking only:** The siren/horn will chirp only when the system locks the doors passively.

## Option Menu Descriptions cont...

### **FO = Default Feature Option**

3-6 Passive alarm and/or doorlock timing: Controls the delay before the passive arm and/or lock features are activated.

**FO1 - Delay of 30 seconds:** The passive features will activate after the selected time.

**FO2 - Delay of 60 seconds:** The passive features will activate after the selected time.

**FO3 - Delay of 5 minutes:** The passive features will activate after the selected time.

**FO4 - Delay of 10 minutes:** The passive features will activate after the selected time.

3-7 Passive open zone bypass (Force rearm): When enabled, passive arming will still occur even if a protected zone such as a door or trunk is still open. Passive arming/locking will still respect the delay selected in menu 3-6.

**FO1 - Disable**

**FO2 - Enable**

3-8 Open zone notification: If a protected zone such as a door or trunk is detected during the arming of the alarm, you can control if there is any notification. You can also delay the notifications which can be useful when you want to allow time for a zone to close.

**FO1 - Disable:** There will be no audible/visual notifications.

**FO2 - Enable (no delay):** 3 chirps/ashes immediately.

**FO3 - Enable with 15 sec delay:** 3 chirps/ashes 15 seconds after arming if a zone is still open.

**FO4 - Enable with 20 sec delay:** 3 chirps/ashes 20 seconds after arming if a zone is still open.

**FO5 - Enable with 25 sec delay:** 3 chirps/ashes 25 seconds after arming if a zone is still open.

**FO6 - Enable with 30 sec delay:** 3 chirps/ashes 30 seconds after arming if a zone is still open.

**FO7 - Enable with 35 sec delay:** 3 chirps/ashes 55 seconds after arming if a zone is still open.

3-9 Confirmation chirp (Horn output): Controls the output for the horn when commands are executed. This does not effect the sounding of the horn when the alarm is triggered. These options do NOT effect the siren output either.

**FO1 - Disable:** No command confirmations to the horn output.

**FO2 - Lock only:** The horn will sound with a lock command only.

**FO3 - Second lock only:** The horn will sound if a second lock command is received within 10 seconds of the first lock command.

**FO4 - Lock and unlock:** The horn will sound with a lock and unlock commands.

**FO5 - Unlock only:** The horn will sound with a unlock command only.

**FO6 - Lock, unlock, start:** The horn will sound with a lock, unlock, and start commands.

**FO7 - Second lock and start:** The horn will sound if a second lock command is received within 10 seconds of the first lock command, as well a start.

## Option Menu Descriptions cont...

### **FO = Default Feature Option**

**3-10 Confirmation chirp (Siren output):** Controls the output for the siren when commands are executed. This does not affect the sounding of the siren when the alarm is triggered. These options do NOT affect the horn output either. **IMPORTANT:** BASEC security activation required for siren output!

**FO1 - Disable:** No command confirmations to the siren output.

**FO2 - Lock only:** The siren will sound with a lock command only.

**FO3 - Second lock only:** The siren will sound if a second lock command is received within 10 seconds of the first lock command.

**FO4 - Lock and unlock:** The siren will sound with a lock and unlock commands.

**FO5 - Unlock only:** The siren will sound with a unlock command only.

**FO6 - Lock, unlock, start:** The siren will sound with a lock, unlock, and start commands.

**FO7 - Second lock and start:** The siren will sound if a second lock command is received within 10 seconds of the first lock command, as well a start.

**3-11 Siren notification from OEM keyless:** Controls if the siren will chirp to confirm arming if the OEM remote is used to lock/unlock. This option requires that OEM keyless detection is supported in the vehicle specific firmware. This feature is NOT available on analog firmware.

**IMPORTANT:** BASEC security activation required for siren output!

**FO1 - Disable**

**FO2 - Enable**

**3-12 Confirmation horn chirp pulse duration:** Used to control the length of the pulse sent to the horn for command confirmations. This is useful if the horn chirps are either too long or too short.

**FO1 - Pulse of 20ms**

**FO2 - Pulse of 30ms**

**FO3 - Pulse of 40ms**

**FO4 - Pulse of 45ms**

**FO5 - Pulse of 50ms**

**FO6 - Pulse of 60ms**

**FO7 - Pulse of 100ms**

**3-13 Shock sensor input behavior:** Controls the shock sensor input behavior for both the internal shock, and external sensor ports. **IMPORTANT:** BASEC security activation required for sensor operation!

**FO1 - Disable:** Both ports are disabled

**FO2 - Enabled:** Both ports are enabled for warn-away and full shock.

**FO3 - Warn away only:** Only the warn-away triggers will be enabled.

**FO4 - Full shock only:** Only the full shock triggers will be enabled.

## Option Menu Descriptions cont...

### **FO = Default Feature Option**

3-14 Analog sensor (-) input behavior: Controls M3 pin-10 (Tan/silver dot) wire. This input can be configured for a variety of different special applications. Read the different option descriptions carefully before making your selection.

**FO1 - Disable**

**FO2 - Warn-away only:** A (-) input will trigger a warn-away notification similar to that of the shock sensor.

**FO3 - Full shock only:** A (-) input will trigger a full alarm similar to that of the shock sensor.

**FO4 - Normally closed alarm:** The input will expect to see (-) constant while the system is armed. If the (-) signal is lost, the alarm will trigger.

**FO5 - Zone 2 passive 15:** This input will always passively arm 15 seconds after zone 2 is closed if the vehicle is not running under key start or in valet mode. Zone 2 will disarm with the system but will ALWAYS passively arm itself regardless if the alarm is in active arming mode. A (-) input is needed to trigger Zone 2.

**FO6 - Zone 2 passive 30:** This input will always passively arm 30 seconds after zone 2 is closed if the vehicle is not running under key start or in valet mode. Zone 2 will disarm with the system but will ALWAYS passively arm itself regardless if the alarm is in active arming mode. A (-) input is needed to trigger Zone 2.

3-15 Alarm & Starter kill control from OEM keyless: When enabled, lock and unlock commands sent from the vehicle's OEM fob will also arm/disarm the FLRSBA alarm and/or starter-kill (if enabled).

**FO1 - Disable**

**FO2 - Enable with remote notification:** OEM commands will control CM alarm and arm/disarm and notifications will be sent to Voxx 2-way transmitters (if installed).

**FO3 - Enable without remote notification:** OEM commands will control CM alarm and arm/disarm but notifications will NOT be sent to Voxx 2-way transmitters (if installed).

3-16 Antenna/External LED: Controls the behavior of the external LED or LED built in to an RF antenna. If enabled, the LED will follow the alarm status.

**FO1 - Disable**

**FO2 - Enable**

3-17 Alarm and panic with parking lights: Controls if the parklights flash during alarm and panic states.

**FO1 - Disable:** No parking lights

**FO2 - Enable:** Parking light during alarm and panic states

## Option Menu Descriptions cont...

### **FO = Default Feature Option**

3-18 Car finder duration: Activating the car finder feature will flash the parklights and sound the horn or siren for the selected time. This feature is activated from an RF transmitter (see transmitter instructions for using this feature. You may need to set an auxiliary output in menu 4).

**FO1 - Duration of 5 seconds**

**FO2 - Duration of 10 seconds**

**FO3 - Duration of 15 seconds**

**FO4 - Duration of 60 seconds**

3-19 Starter-kill / Anti-grind: Controls the behavior of M3 pin-11 BROWN/BLACK (POC4) when configured for starter-kill in menu 5-4.

**FO1 - Anti-Grind + Active Starter-kill:** The output will be active during Remote start and when the system has been armed/locked manually.

**FO2 - Anti-Grind only:** The output will be active during Remote start only.

**FO3 - Anti-Grind + Passive Starter-kill 30 sec:** The output will be active during Remote start and 30 seconds after ignition OFF, or if system has been armed/locked manually.

**FO4 - Anti-Grind + Passive Starter-kill 60 sec:** The output will be active during Remote start and 60 seconds after ignition OFF, or if system has been armed/locked manually.

3-20 Alarm trigger notifications on 2 way transmitters: Controls if alarm trigger notifications are sent to 2-way transmitter programmed to the system. Turning off trigger notifications can increase transmitter battery life.

**FO1 - Disable:** No alarm trigger notifications. Command notifications such as lock/unlock/start always confirm.

**FO2 - Enable:** Full alarm trigger notifications. Command notifications such as lock/unlock/start always confirm as well.

3-21 Alarm first disarm behavior: Controls what happens when you send unlock during an alarm trigger.

**FO1 - Disarm, unlock, silence:** On first unlock command, the system will stop ringing, disarm, unlock the doors.

**FO2 - Silence only:** On first unlock command, the system will stop ringing (silence) but remain armed with the door locked. A second unlock command will disarm and unlock.

3-23 Real panic sound: When enabled, the horn pulses sent during a panic trigger will vary in length (unlike an OEM panic feature) to better draw attention.

**FO1 - Disable**

**FO2 - Enable**

## Option Menu Descriptions cont...

### **FO = Default Feature Option**

3-24 Confirmation siren chirp pulse duration: Controls the pulse duration for the siren on confirmations chirps. **IMPORTANT:** BASEC security activation required for siren output!

**FO1 - Pulse of 20ms**

**FO2 - Pulse of 30ms**

**FO3 - Pulse of 40ms**

**FO4 - Pulse of 45ms**

**FO5 - Pulse of 50ms**

**FO6 - Pulse of 60ms**

**FO7 - Pulse of 100ms**

## Menu #4 : AUX function assignment

**Auxiliary functions can be assigned to button combinations on Voxx RF transmitters, or to command buttons in the Carlink Mobile app. Not all transmitters can support the same numbers of auxiliaries - see the transmitter's guide for more information.**

4-1 Transmitter AUX 1: Sets the action when activating AUX 1 from an RF transmitter

4-2 Transmitter AUX 2: Sets the action when activating AUX 2 from an RF transmitter

4-3 Transmitter AUX 3: Sets the action when activating AUX 3 from an RF transmitter

4-4 Transmitter AUX 4: Sets the action when activating AUX 4 from an RF transmitter

4-5 Transmitter AUX 5: Sets the action when activating AUX 5 from an RF transmitter

Auxiliaries 1 through 5 can be configured for any of the following functions:

**FO1 - Left sliding door:** If supported in vehicle specific firmware, you can assign this feature to any auxiliary to trigger the left sliding door. In analog, assign this feature to an auxiliary, and configure one of the POC's in menu 5 to activate the matching feature.

**FO2 - Right sliding door:** If supported in vehicle specific firmware, you can assign this feature to any auxiliary to trigger the Right sliding door. In analog, assign this feature to an auxiliary, and configure one of the POC's in menu 5 to activate the matching feature.

**FO3 - Pulse Timer Output (PTO1):** A PTO can be set to come on for as little as 1 seconds, or up to 10 minutes. It can also stay on for the entire duration of a remote start cycle. Assign this feature to an auxiliary, and configure one of the POC's in menu 5 to activate the matching feature.

**FO4 - Pulse Timer Output (PTO2):** A PTO can be set to come on for as little as 1 seconds, or up to 10 minutes. It can also stay on for the entire duration of a remote start cycle. Assign this feature to an auxiliary, and configure one of the POC's in menu 5 to activate the matching feature.

**FO5 - Pulse Timer Output (PTO3):** A PTO can be set to come on for as little as 1 seconds, or up to 10 minutes. It can also stay on for the entire duration of a remote start cycle. Assign this feature to an auxiliary, and configure one of the POC's in menu 5 to activate the matching feature.

## Option Menu Descriptions cont...

### **FO = Default Feature Option**

**FO6 - Pulse Timer Output (PTO4):** A PTO can be set to come on for as little as 1 seconds, or up to 10 minutes. It can also stay on for the entire duration of a remote start cycle. Assign this feature to an auxiliary, and configure one of the POC's in menu 5 to activate the matching feature.

**FO7 - Car finder:** Activates the car finder feature of the system. Car finder settings are controlled in menu 3-18.

**FO8 - Gas cap:** If supported in vehicle specific firmware, you can assign this feature to any auxiliary to trigger the gas cap release. In analog, assign this feature to an auxiliary, and configure one of the POC's in menu 5 to activate the matching feature.

**FO9 - Rear glass release:** If supported in vehicle specific firmware, you can assign this feature to any auxiliary to trigger the rear glass release. To trigger a similar feature in analog, use a PTO (3-3 to 3-6).

**FO10 - Heated seats:** If supported in vehicle specific firmware, you can assign this feature to any auxiliary to trigger the heated seats. To trigger a similar feature in analog, use a PTO (3-3 to 3-6).

**FO11 - Cooled seats:** If supported in vehicle specific firmware, you can assign this feature to any auxiliary to trigger the heated seats. To trigger a similar feature in analog, use a PTO (3-3 to 3-6).

**FO12 - Panic:** Activates the panic feature of the system. Panic settings are controlled in menu 3-23.

**FO13 - Defrost:** If supported in vehicle specific firmware, you can assign this feature to any auxiliary to trigger the defrost. In analog, assign this feature to an auxiliary, and configure one of the POC's in menu 5 to activate the matching feature.

## Menu #5 : Programmable Outputs (POC)

**These programmable outputs can be configured to trigger from an Auxiliary as set in menu 4, or can follow a variety of other commands and events.**

5-1 POC 1 negative output (M2 - WHITE/PURPLE/BLACK DOT)

5-2 POC 2 negative output (M2 - PURPLE/BLACK/BLACK DOT)

5-1 POC 3 negative output (M2 - WHITE/BLACK/BLACK DOT)

5-1 POC 1 negative output (M2 - BROWN/BLACK/BLACK DOT)

POC 1 through 4 can be configured for any of the following functions:

**FO1 - Unlock other doors:** Follows the unlock command - This output will trigger on a second unlock press within 10 seconds of the first. Use this to achieve 2 stage unlock when driver's door priority is desired.

**FO2 - Defrost:** This feature is dependent on menu settings 1-23, 1-24. This output will trigger on a successful remote start for the time selected in menu 1-24.

**FO3 - Horn:** Follows the horn output settings in menu settings 3-9, 3-12.

## Option Menu Descriptions cont...

### **FO = Default Feature Option**

**FO4 - Ignition:** Follows the primary ignition wire (M1-05 PINK) output behavior.

**FO5 - Accessory:** Follows the primary accessory wire (M1-01 ORANGE) output behavior.

**FO6 - Starter:** Follows the primary starter wire (M1-03 PURPLE) output behavior.

**FO7 - Parking lights:** Follows the parking light output behavior. Also dependant on the settings in menu 1-20.

**FO9 - Pulse timer output 1 (PTO):** An auxiliary must be assigned to PTO1. The time adjustment for this out is controlled in menu 6-1.

**FO10 - Pulse timer output 2 (PTO):** An auxiliary must be assigned to PTO2. The time adjustment for this out is controlled in menu 6-2.

**FO11 - Pulse timer output 3 (PTO):** An auxiliary must be assigned to PTO3. The time adjustment for this out is controlled in menu 6-3.

**FO12 - Pulse timer output 4 (PTO):** An auxiliary must be assigned to PTO4. The time adjustment for this out is controlled in menu 6-4.

**FO14 - Arm:** Follows the primary arm wire (M2-04 GREEN/WHITE/BLACK DOT) output behavior. Also dependant on the settings in menu 1-15.

**FO15 - Disarm:** Follows the primary disarm wire (M2-05 GREEN/BLACK/BLACK DOT) output behavior. Also dependant on the settings in menu 1-16.

**FO16 - Lock:** Follows the primary lock wire output behavior. Also dependant on the settings in menu 2-1 and 2-4.

**FO17 - Unlock:** Follows the primary unlock wire output behavior. Also dependant on the settings in menu 2-1, 2-3 and 2-5.

**FO18 - Trunk release:** Follows the primary trunk release wire (M2-03 RED/WHITE/BLACK DOT) output behavior. Also dependant on the settings in menu 2-2.

**FO19 - Ground when running (GWR):** Follows the primary GWR wire (M2-06 BLUE/WHITE/BLACK DOT) output behavior.

**FO20 - Left sliding door:** An auxiliary must be assigned to this option in menu 4. The output will pulse 1 sec upon activation of the auxiliary.

**FO21 - Right sliding door:** An auxiliary must be assigned to this option in menu 4. The output will pulse 1 sec upon activation of the auxiliary.

**FO22 - RAP shutdown:** provides a 1 second pulse after remote start shutdown which is often used to shutdown the radio or autolights.

**FO23 - Siren:** Follows the primary siren wire (M2-07 BROWN/BLACK/BLACK DOT) output behavior. Also dependant on the settings in menu 3-10, 3-11 and 3-24.

**FO24 - GND when engine running:** The output will come on after the crank cycle on a successful remote start, and stay on until the runtime expires.

**FO25 - GND when disarmed:** The output will follow the status of the alarm (when activated in menu 3-1) or the doorlocks if the alarm is disabled. The output is on anytime the alarm is in the disarmed state and stays on until the alarm is armed again. If the alarm is disabled, the output is on when the doorlock state us 'unlocked'.

## Option Menu Descriptions cont...

### **FO = Default Feature Option**

**FO26 - Domelight:** The output will come on when the system is disarmed/unlocked and shut off after 30 seconds, or if the doors are re-locked or ignition is turned ON.

**FO27 - GND Headlight output:** This option can be used to activate the headlights for up to 30 seconds following a command from an RF transmitter or Telematic device (Carlink). To control what activates this option see menu 2-18. NOTE: This option will NOT activate from the vehicle's OEM keyless.

**FO28 - RS/Alarm LED:** This option can be used to provide ground (-) to an external LED for RS and alarm status. If using a LED rated for less than 12v, a resistor may be required.

## Menu #6 : Pulse timer output configuration (PTO)

**If any of the POC in menu 5 are set to Pulse Timer output (PTO), you can set the output time using the options below.**

- 6-1 PTO 1 duration (M2 - WHITE/PURPLE/BLACK DOT)
- 6-2 PTO 2 duration (M2 - PURPLE/BLACK/BLACK DOT)
- 6-3 PTO 3 duration (M2 - WHITE/BLACK/BLACK DOT)
- 6-4 PTO 4 duration (M2 - BROWN/BLACK/BLACK DOT)

PTO 1 through 4 can be configured for any of the following durations:

**FO1 - 1 second pulse:** The output will come on for 1 second when activated, regardless if the vehicle is running or not.

**FO2 - Latched 10 seconds:** The output will come on for 1 second when activated, regardless if the vehicle is running or not.

**FO3 - Latched 15 seconds**

**FO4 - Latched 20 seconds**

**FO5 - Latched 30 seconds**

**FO6 - Latched 5 minutes**

**FO7 - Latched 10 minutes**

**FO8 - Latched for runtime:** The output will come on when activated ONLY if the vehicle is running under remote start, and stay on until the runtime expires.

## Option Menu Descriptions cont...

**FO** = Default Feature Option

### Menu #7 : Inputs configuration

**These settings specify the source the system uses for various inputs. The vehicle databus is only used in vehicle specific firmware. When using analog firmware, only analog inputs are used. The default setting for each input is 'Auto' which will automatically take the analog input when no databus input is detected.**

#### 7-1 Brake input source

**FO1 - Analog:** Only the analog input will be used.

**FO2 - Vehicle databus:** The vehicle databus will provide the input when available. Only applies to digital firmware solutions (vehicle specific).

**FO3 - Auto by firmware** The system will look for an input on the vehicle's databus. If the input is not available, or there is no databus connection, the analog input will be used.

#### 7-2 Door input source

**FO1 - Analog:** Only the analog input will be used.

**FO2 - Vehicle databus:** The vehicle databus will provide the input when available. Only applies to digital firmware solutions (vehicle specific).

**FO3 - Auto by firmware** The system will look for an input on the vehicle's databus. If the input is not available, or there is no databus connection, the analog input will be used.

#### 7-3 Tach input source

**FO1 - Analog:** Only the analog input will be used.

**FO2 - Vehicle databus:** The vehicle databus will provide the input when available. Only applies to digital firmware solutions (vehicle specific).

**FO3 - Auto by firmware** The system will look for an input on the vehicle's databus. If the input is not available, or there is no databus connection, the analog input will be used.

#### 7-4 Hood input source

**FO1 - Analog:** Only the analog input will be used.

**FO2 - Vehicle databus:** The vehicle databus will provide the input when available. Only applies to digital firmware solutions (vehicle specific).

**FO3 - Auto by firmware** The system will look for an input on the vehicle's databus. If the input is not available, or there is no databus connection, the analog input will be used.

#### 7-5 Trunk input source

**FO1 - Analog:** Only the analog input will be used.

**FO2 - Vehicle databus:** The vehicle databus will provide the input when available. Only applies to digital firmware solutions (vehicle specific).

**FO3 - Auto by firmware** The system will look for an input on the vehicle's databus. If the input is not available, or there is no databus connection, the analog input will be used.

## Option Menu Descriptions cont...

### **FO = Default Feature Option**

#### 7-6 Glo-plug input source

**FO1 - Analog:** Only the analog input will be used.

**FO2 - Vehicle databus:** The vehicle databus will provide the input when available. Only applies to digital firmware solutions (vehicle specific).

**FO3 - Auto by firmware** The system will look for an input on the vehicle's databus. If the input is not available, or there is no databus connection, the analog input will be used.

#### 7-7 Emergency brake input source

**FO1 - Analog:** Only the analog input will be used.

**FO2 - Vehicle databus:** The vehicle databus will provide the input when available. Only applies to digital firmware solutions (vehicle specific).

**FO3 - Auto by firmware** The system will look for an input on the vehicle's databus. If the input is not available, or there is no databus connection, the analog input will be used.

#### 7-8 Temp sensor input source

**FO1 - Analog:** Only the analog input will be used.

**FO2 - Vehicle databus:** The vehicle databus will provide the input when available. Only applies to digital firmware solutions (vehicle specific).

**FO3 - Auto by firmware** The system will look for an input on the vehicle's databus. If the input is not available, or there is no databus connection, the analog input will be used.

#### 7-9 Speed sensor input source

**FO1 - Analog:** Only the analog input will be used.

**FO2 - Vehicle databus:** The vehicle databus will provide the input when available. Only applies to digital firmware solutions (vehicle specific).

**FO3 - Auto by firmware** The system will look for an input on the vehicle's databus. If the input is not available, or there is no databus connection, the analog input will be used.

#### 7-10 T-harness firmware support

**FO1 - Disable:** No t-harness support (future use)

**FO2 - Enable:** T-harness support (future use)

**FO3 - Auto by firmware** The system will automatically determine if a T-harness is supported. Only applies to digital firmware solutions (vehicle specific).

#### 7-11 Digital shock sensor

**FO2 - Internal:** specifies the default source for the shock sensor.

#### 7-12 Digital tilt sensor

**FO2 - Internal:** specifies the default source for the tilt sensor.

#### 7-20 Temperature sensor adjustment

**FO1 to FO30:** If the temperature reported by the CM does not match the actual temperature outside, you can use this setting to adjust the reported temp up or down +/- 30 degrees.

## Option Menu Descriptions cont...

**FO = Default Feature Option**

### Menu #8 : Outputs configuration

**These settings specify how the system treats various outputs. The vehicle databus is only used in vehicle specific firmware. When using analog firmware, only analog outputs are used. The default setting for each output is 'Auto' which will automatically use the analog output when no databus interface is available.**

#### 8-1 Arm output source

**FO1 - Analog output only:** Only the analog output will be used.

**FO2 - Analog output and on Databus when available:** If using a digital firmware solutions (vehicle specific) the output may be sent in data. The output is always sent in analog as well.

#### 8-2 Disarm output source

**FO1 - Analog output only:** Only the analog output will be used.

**FO2 - Analog output and on Databus when available:** If using a digital firmware solutions (vehicle specific) the output may be sent in data. The output is always sent in analog as well.

#### 8-3 Lock output source

**FO1 - Analog output only:** Only the analog output will be used.

**FO2 - Analog output and on Databus when available:** If using a digital firmware solutions (vehicle specific) the output may be sent in data. The output is always sent in analog as well.

#### 8-4 Unlock driver's door output source

**FO1 - Analog output only:** Only the analog output will be used.

**FO2 - Analog output and on Databus when available:** If using a digital firmware solutions (vehicle specific) the output may be sent in data. The output is always sent in analog as well.

#### 8-5 Unlock others output source

**FO1 - Analog output only:** Only the analog output will be used.

**FO2 - Analog output and on Databus when available:** If using a digital firmware solutions (vehicle specific) the output may be sent in data. The output is always sent in analog as well.

#### 8-6 Trunk release output source

**FO1 - Analog output only:** Only the analog output will be used.

**FO2 - Analog output and on Databus when available:** If using a digital firmware solutions (vehicle specific) the output may be sent in data. The output is always sent in analog as well.

#### 8-7 Left sliding door output source

**FO1 - Analog output only:** Only the analog output will be used.

**FO2 - Analog output and on Databus when available:** If using a digital firmware solutions (vehicle specific) the output may be sent in data. The output is always sent in analog as well.

#### 8-8 Right sliding door output source

**FO1 - Analog output only:** Only the analog output will be used.

**FO2 - Analog output and on Databus when available:** If using a digital firmware solutions (vehicle specific) the output may be sent in data. The output is always sent in analog as well.

**FO = Feature Option**

## 8-9 Parking light output source

**FO1 - Analog output only:** Only the analog output will be used.

**FO2 - Analog output and on Databus when available:** If using a digital firmware solutions (vehicle specific) the output may be sent in data. The output is always sent in analog as well.

## 8-10 RAP shutdown output source

**FO1 - Analog output only:** Only the analog output will be used.

**FO2 - Analog output and on Databus when available:** If using a digital firmware solutions (vehicle specific) the output may be sent in data. The output is always sent in analog as well.

## 8-11 Panic and alarm output source

**FO1 - Analog output only:** Only the analog output will be used.

**FO2 - Analog output and on Databus when available:** If using a digital firmware solutions (vehicle specific) the output may be sent in data. The output is always sent in analog as well.

## 8-12 Car finder output source

**FO1 - Analog output only:** Only the analog output will be used.

**FO2 - Analog output and on Databus when available:** If using a digital firmware solutions (vehicle specific) the output may be sent in data. The output is always sent in analog as well.

## 8-13 Defrost output source

**FO1 - Analog output only:** Only the analog output will be used.

**FO2 - Analog output and on Databus when available:** If using a digital firmware solutions (vehicle specific) the output may be sent in data. The output is always sent in analog as well.

## 8-14 Horn chirp output source

**FO1 - Analog output only:** Only the analog output will be used.

**FO2 - Analog output and on Databus when available:** If using a digital firmware solutions (vehicle specific) the output may be sent in data. The output is always sent in analog as well.

## 8-15 Sleep status on module LED

**FO1 - Disable**

**FO2 - Enable**

## 8-16 Siren chirp output source

**FO1 - Analog output only:** Only the analog output will be used.

**FO2 - Analog output and on Databus when available:** If using a digital firmware solutions (vehicle specific) the output may be sent in data. The output is always sent in analog as well.

## Troubleshooting

### Module diagnostic codes

The following chart illustrates the different diagnostic flashes you may see during the setup and programming of the CM. If you are using a vehicle specific firmware, there may be additional diagnostic codes.

If so, contact technical support for assistance.

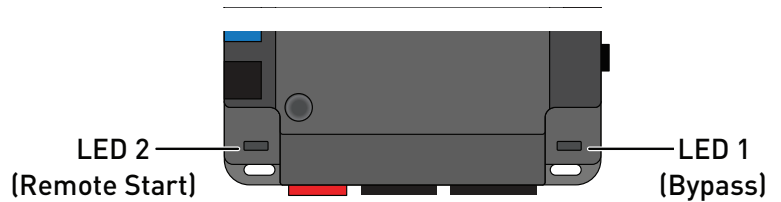

Module testing		LED 1	LED 2	LED status	Diagnostic
1	DURING MODULE PROGRAMMING	•		Flashing RED	Missing/wrong information from firmware or vehicle. See firmware specific diagnostics or contact technical support.
		•		Solid RED	Module waiting for more vehicle information. Programming incomplete.
		•		Flashing GREEN	Additional steps required to complete programming. Refer to install guide.
		•		Solid GREEN then OFF	Module programming completed successfully.
		•		OFF	No activity or module already programmed.
			•	1 RED flash	No firmware on module. Connect to weblink and flash device.
			•	3 ORANGE flashes	Module programming not completed.
			•	8 ORANGE flashes	Loop not cut. Ensure loop is cut for Automatic transmission. Reset and re-learn.
2	DURING TACH PROGRAMMING		•	1 GREEN flash	Tach signal programmed in Analog
			•	2 GREEN flashes	Tach signal programmed in Data
			•	3 RED flashes	No tach signal detected
			•	4 RED flashes	System is in valet mode
			•	5 RED flashes	N/A
			•	6 RED flashes	Tach set for 'assumed start'. No tach programming required
3	DURING REMOTE START		•	Flashing RED	Module incorrectly programmed.
			•	Solid RED	Module incorrectly programmed.
			•	Flashing GREEN	Remote start cycle in progress. Working correctly.
		•		Flashing GREEN	Remote start cycle in progress. Displays vehicle platform during runtime.
		•		Rapid GREEN flashing	Secure takeover initiated. Waiting to complete takeover after brake press.

## Troubleshooting cont...

### Remote Start Error Codes

If the remote start fails to start the vehicle, the parking lights will flash three times immediately. Following those two flashes the parking lights will flash again corresponding to the error table below:

3x flashes followed by...	Remote Start Error
1	Motor running or must program tach before 1st remote start
2	Key in ignition on position
3	Door open
5	Foot brake on
6	Hood open
7	Reservation off (manual transmission only)
8	Tach sensing failure
9	VSS detected
10	System is in Valet Mode
11	Lost communication with vehicle (CAN, J1850...)
12	Need to resync with vehicle, do a key cycle...
13	Bypass error code

2 Way remotes will display the error number "Strt Er##" on the LCD.

### Remote Start Shutdown Error Codes

If the remote start sequence has been completed and the vehicle shuts down, the vehicle's parking lights will flash 4 times, pause then flash again with the error code. Tap button 4 on 2 Way remotes to initiate the shutdown error codes. On 1 Way remotes hold the Trunk and Start buttons together for 2.5 seconds.

4x flashes followed by...	Remote Start Shutdown Error
1	Engine tach signal is lost.
2	Emergency brake is lost.
3	Foot brake is ON.
4	Hood is open
5	Engine RPM limit engaged
6	Glow plug timeout error
7	Vehicle is moving (VSS)
8	N/A
9	N/A
10	Door is open
12	CAN communication failure during RS sequence.
13	RS out of sync. Start vehicle with OEM key for 15 sec before a new RS sequence.
14	Takeover is not allowed
15	Shutdown error, board overheat protection

## Troubleshooting cont...

### Alarm LED Diagnostics

When the alarm is triggered the LED on the RPS (if installed), and the LED (if installed) will flash a certain amount of times as shown in the table below. The error code will only flash on the LED until unlock is pressed and then the error code will be repeated by the pk lights upon unlock.

5x flashes followed by...	Alarm trigger codes
1	Shock detected
2	Door opened
3	Trunk opened
4	Hood opened
5	Zone 2
6	Brake detected
7	Ignition detected
8	Motion detected
9	Tilt detected
10	Warnaway detected

## Frequently Asked Questions

### **I have everything hooked up and the system will not respond.**

A: The module must first be flashed on the web before it can be used in a vehicle. If you have already flashed and programmed your control module, you must also program any transmitters to the system before they can be used. See 'Installation Basics'.

### **When remote starting, the parking lights flash 3 then 1 time.**

A: You must program tach before remote starting. This requires that the foot brake and ignition inputs connected and working properly. See the 'Tach sensing & learning' section.

### **When remote starting, the parking lights flash 3 then 7 times.**

A: The system is in Manual Transmission mode. If installing on an automatic vehicle, you must cut the BLACK loop on the control module. If you have already completed programming, you must cut the loop, then perform a system reset and repeat the programming and tach learn.

### **Does the FLRSBA series have hybrid mode?**

A: Yes. For details, review the "Tach sensing and learning" section of this manual.

### **All my connections are made and remotes programmed, how do I program the tach?**

A: Review the "Tach sensing and learning" section of this manual.

## Frequently Asked Questions cont...

### **Whenever I try to arm the vehicle, it chirps the siren 3 times instead of just once.**

A: Open zone detected. Check the hood and trunk, and door trigger inputs.

### **Do the door locks flip flop in polarity?**

A: No. You can use the DLVI harness used for low current 1000mA positive (+) locks.

### **The vehicle starts and shuts down 3 times in a row.**

A: This usually means that the engine sensing mode is not working correctly. If you are using a coil, change to an injector.

B: Does your vehicle have an immobilizer system which will need to be bypassed for remote start? If using analog firmware, you will be required to take extra steps to complete your installation. Please contact technical support.

### **The vehicle cranks but will not start (armed or disarmed).**

A: Check ignition switch wiring including starter-kill relay (if installed).

B: Does your vehicle have an immobilizer system which will need to be bypassed for remote start? If using analog firmware, you will be required to take extra steps to complete your installation. Please contact technical support.

### **The vehicle remote starts when disarmed, but not when armed.**

A: Did you install a starter kill relay? If so, check to make sure the M1 Violet wire is connected wire is going to the engine side of your vehicle's starter wire.

### **On the brain, how do I set the auxiliaries?**

A: You must connect the FLRSBA to Weblink via your PC or Weblink Mobile app. Go to menus 4, 5, 6 in the options settings. You can program up to 4 outputs for a variety of applications. See the "menu Option Descriptions" section for details.

### **Do I need to use a decoder with my RF kit?**

A: The FLRSBA has a built-in decoder. Compatible Voxx RF kits plug directly into either the 6-pin (Prestige/Pursuit) or the 5-pin (Code Alarm) RF ports. See the wiring diagram on page 2.

### **How do I make the alarm work?**

A: The FLRSBA's alarm must be turned on and configured using configuration menu 3-1. See the 'Option programming tables' section for details. To activate full security features such as Siren output and Shock sensor, you will need a BASEC security activation card with an unlock code.

Activations are linked to the device, so you can flash the device multiple times for different vehicles without affecting the activation status.

## Frequently Asked Questions cont...

### **Can I use the wires in the blue 6 pin M5 connector? Is it user programmable?**

A: The wires in M6 are controlled in firmware for vehicle specific applications. In full analog, these outputs are disabled.

### **I don't have access to the module, how do I learn tach?**

A: If you have a transmitter programmed to the system, it can be used to perform a tach learn. Start the vehicle with the key, apply the foot brake, then initiate a start sequence from the transmitter. The parklights will flash 1 or 2 times to confirm learn. See the 'Tach sensing and learning' section for more information.

### **How do I activate turbo mode?**

A: Set menu option 1-12 to enable Turbo mode. Refer to your transmitter's manual for instructions on activating this feature when you exit the vehicle.

## Technical Support Contacts

Voxx technical support is reserved for authorized dealers only.

Monday - Friday:           **VOXX** 800.225.6074  
   **CODE ALARM** 800.421.3209

Web:                           www.flashlogic.com

### **Wiring Diagrams**

Diagrams for most vehicles are available when you flash your module at flashlogic.com. If you are an authorized dealer and unable to access this site please contact your sales rep or call technical support.