



HOW TO USE THIS INSTALL GUIDE

- 1** Open the Bookmarks menu and find your vehicle OR scroll down until you find the install guide for your vehicle.
- 2** Print only the pages for your vehicle using the advanced options in the Print menu.
- 3** Install your Maestro RR according to the guide for your vehicle.

WARNING

Pressing the printer icon or “quick printing” this document will print all of the guides in this compilation.

RETAINS STEERING WHEEL CONTROLS, FACTORY AMPLIFIER, AND MORE!



PRODUCTS REQUIRED

iDatalink Maestro RR or RR2 Radio Replacement Interface
iDatalink Maestro HRR-T01 Installation Harness

PROGRAMMED FIRMWARE

ADS-RR(SR)-TOY01-DS

ADDITIONAL RESOURCES

[Maestro RR2 Programmable Outputs Guide](#)

OPTIONAL ACCESSORIES

K40[™]
ELECTRONICS
ESCORT

Click here for:
[Radar Installation Guides](#)

HEAD UNIT ADAPTER:
ACC-HU-PI01, SON1, KEN1, KEN2, ALP1

WELCOME

Congratulations on the purchase of your iDatalink Maestro RR Radio replacement solution. You are now a few simple steps away from enjoying your new car radio with enhanced features.

Before starting your installation, please ensure that your iDatalink Maestro module is programmed with the correct firmware for your vehicle and that you carefully review the install guide.

Please note that Maestro RR will only retain functionalities that were originally available in the vehicle.

NEED HELP?

 1 866 427-2999

 maestro.support@idatalink.com

TABLE OF CONTENTS

Installation Instructions	3
Wiring Diagram	4
Radio Wire Reference Chart	5
Module Diagnostics	6
Troubleshooting Table	7

INSTALLATION INSTRUCTIONS P1/1

STEP 1

Remove the factory radio

If using head unit adapter (sold separately), connect HRR-T01 harness to adapter and skip to step 2.

- Unbox the aftermarket radio and locate its main harness.
- Cut and remove the black 20 pin connector from the HRR-T01 T-harness and connect the wires, shown in the wiring diagram, from aftermarket radio main harness to the HRR-T01 T-harness and match the wire functions.

Note: only connect purple/white wire to radio reverse input or module damage will occur.

STEP 2

- If the vehicle is equipped with an OEM backup camera, connect the HRR-T01 harness to appropriate HRR adapter cable (D, E or F) then connect to the backup camera harness.

STEP 3

- Identify if your vehicle has a 20 or 28 pin secondary connector.
- Assemble T01 T-harness as shown on wiring diagram.
- Connect the factory harness to the HRR-T01 harness.

STEP 4

- Connect HRR-T01 3-pin black connector to black connector of OBDII extension harness.
- Plug the OBDII connector into the OBDII of the vehicle.

STEP 5

- Plug the harnesses into the aftermarket radio.
- Connect the backup camera RCA cable into the aftermarket radio (if equipped).
- Plug the Data cable to the data port of the aftermarket radio.
- Insert the Audio cable into the iDatalink 3.5 mm audio jack of the aftermarket radio (if there is no iDatalink audio input, connect to AUX).

Note: On Pioneer radio, ensure that there is nothing plugged into the W/R port.

STEP 6

- Connect all the harnesses to the Maestro RR module then test your installation.

WIRING DIAGRAM *without an Amplifier*

STEP 1

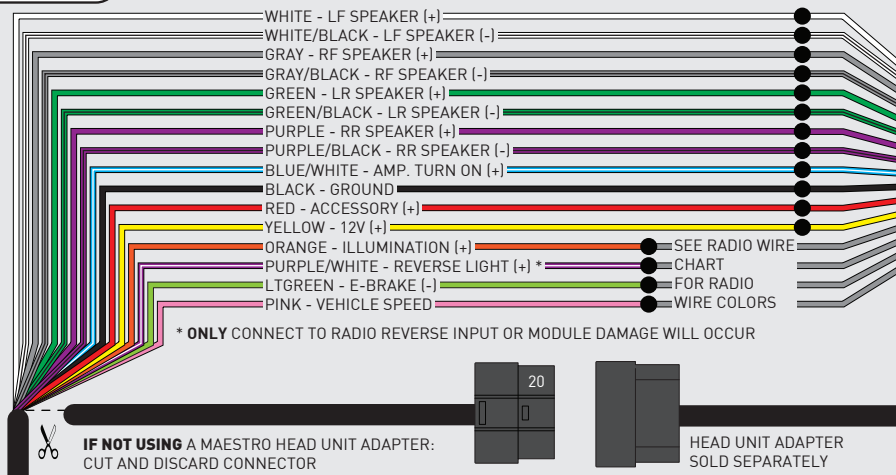

STEP 5

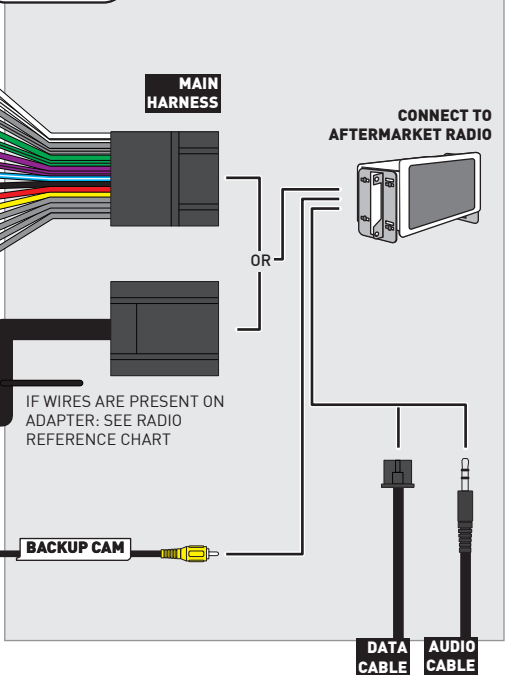

STEP 2

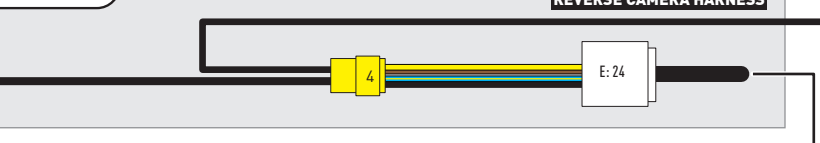

STEP 3

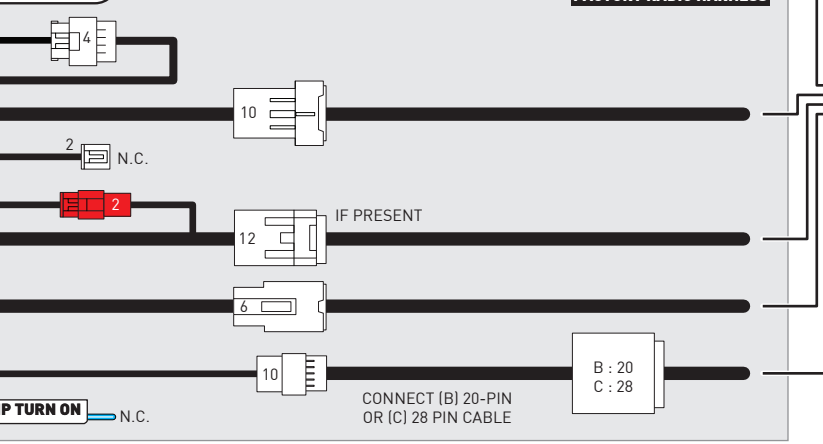

STEP 4



STEP 6

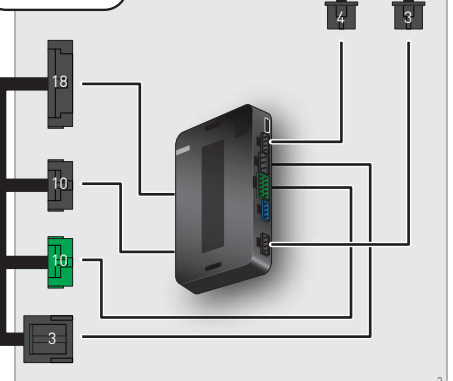

NOT REQUIRED

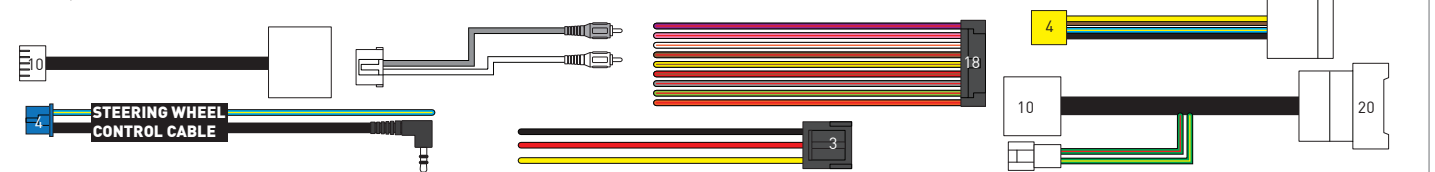

RADIO WIRE REFERENCE CHART

T01 T-harness Wire Description	Polarity	Wire Color on Maestro T-Harness	Wire Color on Alpine cable	Wire Color on Kenwood/JVC cable	Wire Color on Pioneer cable	Wire Color on Sony cable
Illumination	(+)	Orange	N/A	Orange/White	Orange/White	Orange
Reverse Light*	(+)	Purple/White	Orange/White	Purple/White	Purple/White	Purple/White
E-Brake	(-)	Lt Green	Yellow/Blue	Lt Green	Lt Green	Lt Green
VSS (vehicle speed sensor)	(DATA)	Pink	Green/White	Pink	Pink	N/A

Head unit adapter wiring (optional accessory, sold separately)

ACC-HU-ALP1 Wire Description	Polarity	Wire Color on Adapter	Alpine Radio
VSS (vehicle speed sensor)	(DATA)	Green/White	Green/White

ACC-HU-KEN1 Wire Description	Polarity	Wire Color on Adapter	Kenwood Radio
CAM	(+)	Green/Red	Refer to camera/radio manual
CAM	(-)	Green/White	Refer to camera/radio manual
Steering Wheel Controls	(DATA)	Blue/Yellow	n/a

ACC-HU-KEN2 Wire Description	Polarity	Wire Color on Adapter	Kenwood Radio
E-Brake	(-)	LtGreen	LtGreen
Reverse Light*	(+)	Purple/White	Purple/White
Steering Wheel Controls	(DATA)	Blue/Yellow	n/a

* Reverse light wire: Only connect to radio or module damage will occur.

MODULE DIAGNOSTICS



LED 1 Module/Firmware status	LED 2 (RR2) Bluetooth activity	LED STATUS	DIAGNOSTIC
or		RED or GREEN flashing	LED flashes 1 or more times, either red or green, when a steering wheel button is pressed : normal operation.
		1 RED flash	Module has no firmware. Flash module using Weblink Desktop and log in. Do <u>NOT</u> use DEMO MODE.
		2 RED flashes	Problem detected. Consult troubleshooting table.
		1 GREEN flash	After radio boots up : Normal operation.
		3 GREEN flashes	Bluetooth is activated. Turns off after one minute: Normal operation.
		OFF	Normal operation (inactive).

VIDEO HELP		Installation, product information, vehicle specific videos.
VERIFY FLASH		Last flash information, steering control configuration, vehicle information.
WEBLINK		Software to program module.

TROUBLESHOOTING TABLE

PROBLEM	SOLUTION
Gauges do not work, radio shows OBD2 Error 1 or Error 2.	<p>Ensure OBDII connector is securely attached to the OBDII connector of the vehicle.</p> <p>If you hardwired connections at the OBDII, check connections at the OBDII connector. Make sure the RED/BROWN wire is on PIN 6 and the YELLOW/BROWN wire is connected to PIN 14 of the OBDII connector. Do not use T-Taps. Soldering or military splicing methods are recommended.</p> <p>If anything else is connected to the OBD2 or CAN wires of vehicle (programmer, throttle controller, insurance tracker, etc.) try unplugging it to see if gauges work. If gauges work without it installed, call tech support for options.</p> <p>Reset the RR.</p>
The light on the Maestro is blinking RED TWICE and the radio IS turning on.	<p>Ensure the 4-pin data cable is connected between the radio and the RR, and that it is plugged into the black port on the Maestro RR. The red and blue ports on the RR should be empty.</p> <p>Make sure the correct radio model and serial number were entered during the flash. Verify the radio's serial number entered during the flash matches what is listed on the radio screen. This can be found in the settings of the radio, listed as Device Id, Device Number, or Serial Number.</p>
The light on the Maestro is blinking RED TWICE but the radio is NOT turning on.	<p>If installing a modular radio and it is not turning on, ensure the screen is secured and any trim pieces on the radio have been installed fully. Not installing these fully will prevent radio from powering up and show a 2x red error as well.</p> <p>Test red and yellow wires for DC voltage at radio using a multimeter. Contact support if no voltage on red or yellow.</p>
The steering wheel controls are not working, the Maestro RR does not blink when they are pressed.	<p>Ensure the 20 or 28-pin connector is plugged to the vehicle and to the T01 T-harness, as shown in step 3 (this is where the RR gets the steering wheel signal from the vehicle).</p>
(Prius only) After the car is turned off, the radio stays on. The car stays in accessory mode and will not turn off.	<p>Locate the white 12-pin connector of the T01 harness, it is connected to the vehicle harness.</p> <p>Then, cut and isolate the red wire located at pin 11. The radio will shut off when the vehicle is turned off.</p>

MAESTRO RR RESET PROCEDURE:

Turn the key to the OFF position, then disconnect all connectors from the module.

Press and hold the module's programming button and connect all the connectors back to the module. Wait, the module's LED will flash RED rapidly (this may take up to 10 seconds).

Release the programming button. Wait, the LED will turn solid GREEN for 2 seconds to show the reset was successful.

TECHNICAL ASSISTANCE

Phone: 1-866-427-2999

Email: maestro.support@idatalink.com

IMPORTANT: To ensure proper operation, the aftermarket radio needs to have the latest firmware from the manufacturer. Please visit the radio manufacturer's website and look for any updates pertaining to your radio.

RETAINS STEERING WHEEL CONTROLS, FACTORY AMPLIFIER, AND MORE!



PRODUCTS REQUIRED

iDatalink Maestro RR or RR2 Radio Replacement Interface
iDatalink Maestro HRR-T01 Installation Harness

PROGRAMMED FIRMWARE

ADS-RR(SR)-TOY01-DS

ADDITIONAL RESOURCES

[Maestro RR2 Programmable Outputs Guide](#)

OPTIONAL ACCESSORIES

K40[™]
ELECTRONICS
ESCORT

Click here for:
[Radar Installation Guides](#)

HEAD UNIT ADAPTER:
ACC-HU-PI01, SON1, KEN1, KEN2, ALP1

WELCOME

Congratulations on the purchase of your iDatalink Maestro RR Radio replacement solution. You are now a few simple steps away from enjoying your new car radio with enhanced features.

Before starting your installation, please ensure that your iDatalink Maestro module is programmed with the correct firmware for your vehicle and that you carefully review the install guide.

Please note that Maestro RR will only retain functionalities that were originally available in the vehicle.

NEED HELP?

 1 866 427-2999

 maestro.support@idatalink.com

TABLE OF CONTENTS

Installation Instructions	3
Wiring Diagram	4
Radio Wire Reference Chart	5
Module Diagnostics	6
Troubleshooting Table	7

INSTALLATION INSTRUCTIONS P1/1

STEP 1

Remove the factory radio

If using head unit adapter (sold separately), connect HRR-T01 harness to adapter and skip to step 2.

- Unbox the aftermarket radio and locate its main harness.
- Cut and remove the black 20 pin connector from the HRR-T01 T-harness and connect the wires, shown in the wiring diagram, from aftermarket radio main harness to the HRR-T01 T-harness and match the wire functions.

Note: only connect purple/white wire to radio reverse input or module damage will occur.

STEP 2

- Identify if your vehicle has a 20 or 28 pin secondary connector.
- Assemble T01 T-harness as shown on wiring diagram.
- Connect the factory harness to the HRR-T01 harness.

STEP 3

- Connect HRR-T01 3-pin black connector to black connector of OBDII extension harness.
- Plug the OBDII connector into the OBDII of the vehicle.

STEP 4

- Plug the harnesses into the aftermarket radio.
- Plug the Data cable to the data port of the aftermarket radio.
- Insert the Audio cable into the iDatalink 3.5 mm audio jack of the aftermarket radio (if there is no iDatalink audio input, connect to AUX).

Note: On Pioneer radio, ensure that there is nothing plugged into the W/R port.

STEP 5

- Connect all the harnesses to the Maestro RR module then test your installation.

WIRING DIAGRAM *without an Amplifier*

STEP 1

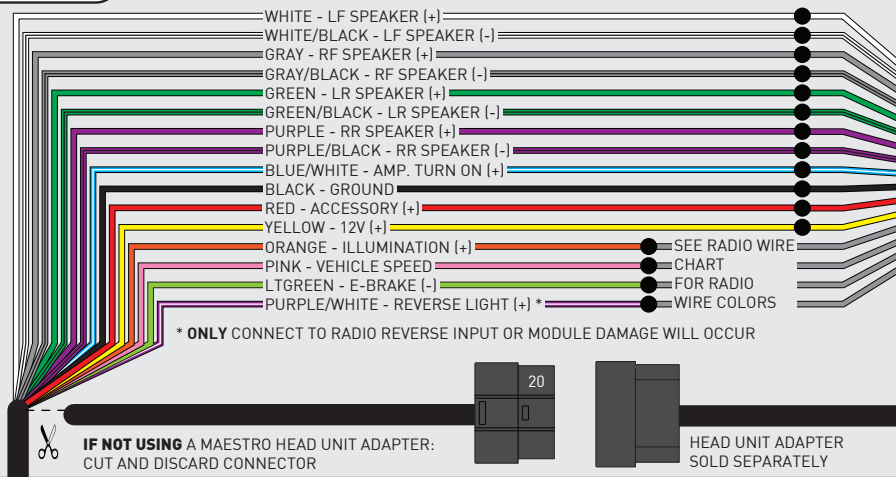

STEP 4

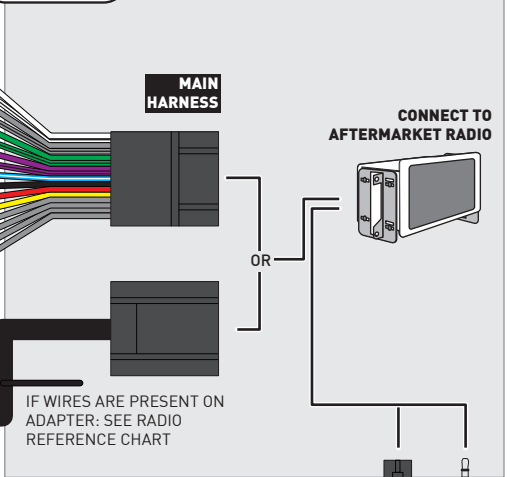

STEP 2

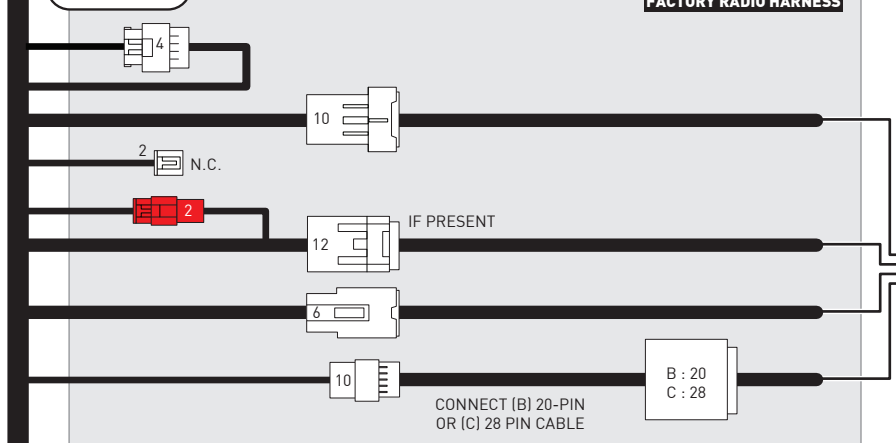

STEP 3

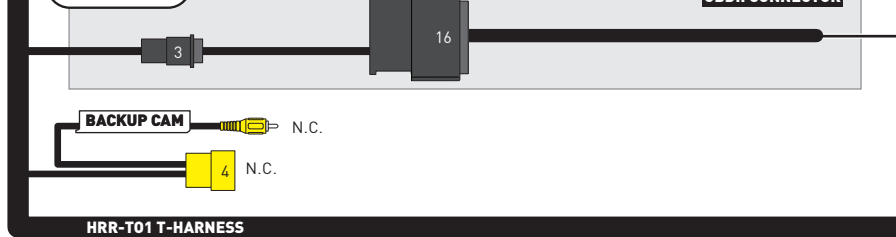

STEP 5

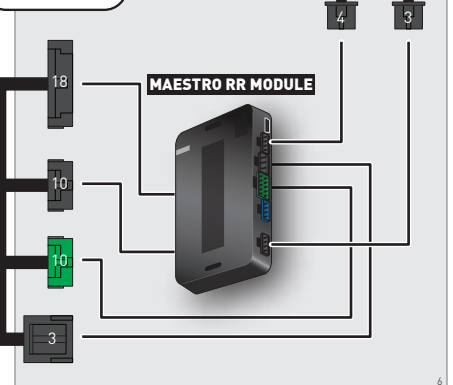

NOT REQUIRED

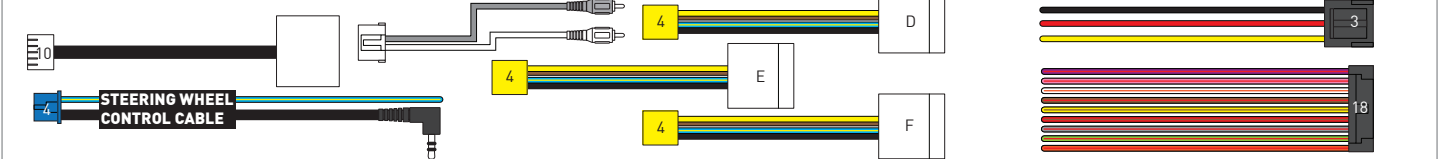

RADIO WIRE REFERENCE CHART

T01 T-harness Wire Description	Polarity	Wire Color on Maestro T-Harness	Wire Color on Alpine cable	Wire Color on Kenwood/ JVC cable	Wire Color on Pioneer cable	Wire Color on Sony cable
Illumination	(+)	Orange	N/A	Orange/White	Orange/White	Orange
Reverse Light*	(+)	Purple/White	Orange/White	Purple/White	Purple/White	Purple/White
E-Brake	(-)	Lt Green	Yellow/Blue	Lt Green	Lt Green	Lt Green
VSS (vehicle speed sensor)	(DATA)	Pink	Green/White	Pink	Pink	N/A

Head unit adapter wiring (optional accessory, sold separately)

ACC-HU-ALP1 Wire Description	Polarity	Wire Color on Adapter	Alpine Radio
VSS (vehicle speed sensor)	(DATA)	Green/White	Green/White

ACC-HU-KEN1 Wire Description	Polarity	Wire Color on Adapter	Kenwood Radio
CAM	(+)	Green/Red	Refer to camera/radio manual
CAM	(-)	Green/White	Refer to camera/radio manual
Steering Wheel Controls	(DATA)	Blue/Yellow	n/a

ACC-HU-KEN2 Wire Description	Polarity	Wire Color on Adapter	Kenwood Radio
E-Brake	(-)	LtGreen	LtGreen
Reverse Light*	(+)	Purple/White	Purple/White
Steering Wheel Controls	(DATA)	Blue/Yellow	n/a

* Reverse light wire: Only connect to radio or module damage will occur.

MODULE DIAGNOSTICS



LED 1 Module/Firmware status	LED 2 (RR2) Bluetooth activity	LED STATUS	DIAGNOSTIC
or		RED or GREEN flashing	LED flashes 1 or more times, either red or green, when a steering wheel button is pressed : normal operation.
		1 RED flash	Module has no firmware. Flash module using Weblink Desktop and log in. Do <u>NOT</u> use DEMO MODE.
		2 RED flashes	Problem detected. Consult troubleshooting table.
		1 GREEN flash	After radio boots up : Normal operation.
		3 GREEN flashes	Bluetooth is activated. Turns off after one minute: Normal operation.
		OFF	Normal operation (inactive).

VIDEO HELP		Installation, product information, vehicle specific videos.
VERIFY FLASH		Last flash information, steering control configuration, vehicle information.
WEBLINK		Software to program module.

TROUBLESHOOTING TABLE

PROBLEM	SOLUTION
Gauges do not work, radio shows OBD2 Error 1 or Error 2.	Ensure OBDII connector is securely attached to the OBDII connector of the vehicle. If you hardwired connections at the OBDII, check connections at the OBDII connector. Make sure the RED/BROWN wire is on PIN 6 and the YELLOW/BROWN wire is connected to PIN 14 of the OBDII connector. Do not use T-Taps. Soldering or military splicing methods are recommended. If anything else is connected to the OBD2 or CAN wires of vehicle (programmer, throttle controller, insurance tracker, etc.) try unplugging it to see if gauges work. If gauges work without it installed, call tech support for options. Reset the RR.
The light on the Maestro is blinking RED TWICE and the radio IS turning on.	Ensure the 4-pin data cable is connected between the radio and the RR, and that it is plugged into the black port on the Maestro RR. The red and blue ports on the RR should be empty. Make sure the correct radio model and serial number were entered during the flash. Verify the radio's serial number entered during the flash matches what is listed on the radio screen. This can be found in the settings of the radio, listed as Device Id, Device Number, or Serial Number.
The light on the Maestro is blinking RED TWICE but the radio is NOT turning on.	If installing a modular radio and it is not turning on, ensure the screen is secured and any trim pieces on the radio have been installed fully. Not installing these fully will prevent radio from powering up and show a 2x red error as well. Test red and yellow wires for DC voltage at radio using a multimeter. Contact support if no voltage on red or yellow.
The steering wheel controls are not working, the Maestro RR does not blink when they are pressed.	Ensure the 20 or 28-pin connector is plugged to the vehicle and to the T01 T-harness, as shown in step 3 (this is where the RR gets the steering wheel signal from the vehicle).
(Prius only) After the car is turned off, the radio stays on. The car stays in accessory mode and will not turn off.	Locate the white 12-pin connector of the T01 harness, it is connected to the vehicle harness. Then, cut and isolate the red wire located at pin 11. The radio will shut off when the vehicle is turned off.

MAESTRO RR RESET PROCEDURE:

Turn the key to the OFF position, then disconnect all connectors from the module.

Press and hold the module's programming button and connect all the connectors back to the module. Wait, the module's LED will flash RED rapidly (this may take up to 10 seconds).

Release the programming button. Wait, the LED will turn solid GREEN for 2 seconds to show the reset was successful.

TECHNICAL ASSISTANCE

Phone: 1-866-427-2999

Email: maestro.support@idatalink.com

IMPORTANT: To ensure proper operation, the aftermarket radio needs to have the latest firmware from the manufacturer. Please visit the radio manufacturer's website and look for any updates pertaining to your radio.

RETAINS STEERING WHEEL CONTROLS, FACTORY AMPLIFIER, AND MORE!



PRODUCTS REQUIRED

iDatalink Maestro RR or RR2 Radio Replacement Interface
iDatalink Maestro HRR-T01 Installation Harness

PROGRAMMED FIRMWARE

ADS-RR(SR)-TOY01-DS

ADDITIONAL RESOURCES

[Maestro RR2 Programmable Outputs Guide](#)

OPTIONAL ACCESSORIES

K40
ELECTRONICS
ESCORT

Click here for:
[Radar Installation Guides](#)

HEAD UNIT ADAPTER:
ACC-HU-PI01, SON1, KEN1, KEN2, ALP1

WELCOME

Congratulations on the purchase of your iDatalink Maestro RR Radio replacement solution. You are now a few simple steps away from enjoying your new car radio with enhanced features.

Before starting your installation, please ensure that your iDatalink Maestro module is programmed with the correct firmware for your vehicle and that you carefully review the install guide.

Please note that Maestro RR will only retain functionalities that were originally available in the vehicle.

TABLE OF CONTENTS

Installation Instructions	3
Wiring Diagram	4
Radio Wire Reference Chart	5
Module Diagnostics	6
Troubleshooting Table	7

NEED HELP?

 1 866 427-2999

 maestro.support@idatalink.com

INSTALLATION INSTRUCTIONS P1/1

STEP 1

Remove the factory radio

If using head unit adapter (sold separately), connect HRR-T01 harness to adapter and skip to step 2.

- Unbox the aftermarket radio and locate its main harness.
- Cut and remove the black 20 pin connector from the HRR-T01 T-harness and connect the wires, shown in the wiring diagram, from aftermarket radio main harness to the HRR-T01 T-harness and match the wire functions.

Note: only connect purple/white wire to radio reverse input or module damage will occur.

STEP 2

- Identify if your vehicle has a 20 or 28 pin secondary connector.
- Assemble T01 T-harness as shown on wiring diagram.
- Connect the factory harness to the HRR-T01 harness.

STEP 3

- Connect HRR-T01 3-pin black connector to black connector of OBDII extension harness.
- Plug the OBDII connector into the OBDII of the vehicle.

STEP 4

- Plug the harnesses into the aftermarket radio.
- Plug the Data cable to the data port of the aftermarket radio.
- Insert the Audio cable into the iDatalink 3.5 mm audio jack of the aftermarket radio (if there is no iDatalink audio input, connect to AUX).

Note: On Pioneer radio, ensure that there is nothing plugged into the W/R port.

STEP 5

- Connect all the harnesses to the Maestro RR module then test your installation.

WIRING DIAGRAM *without an Amplifier*

STEP 1

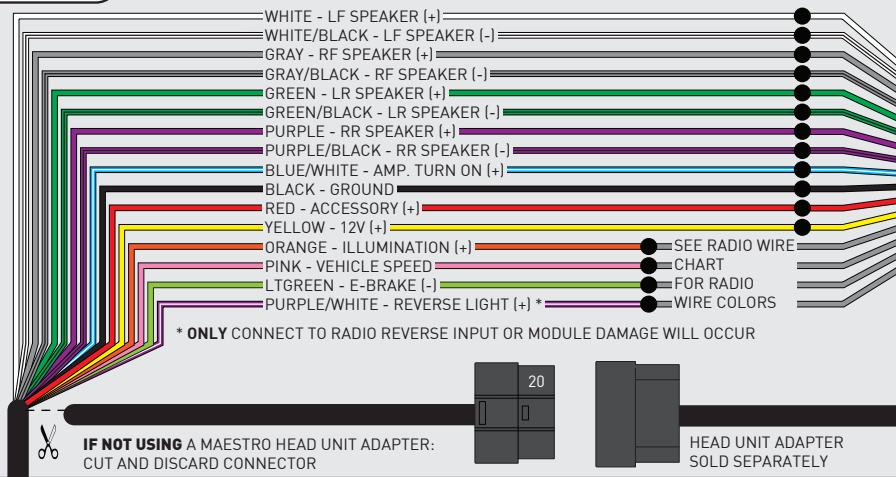

STEP 4

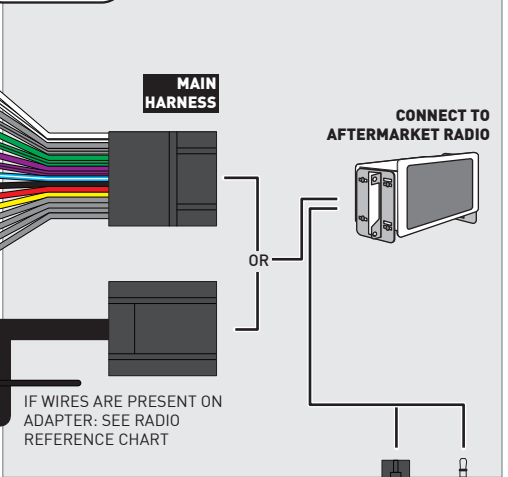

STEP 2

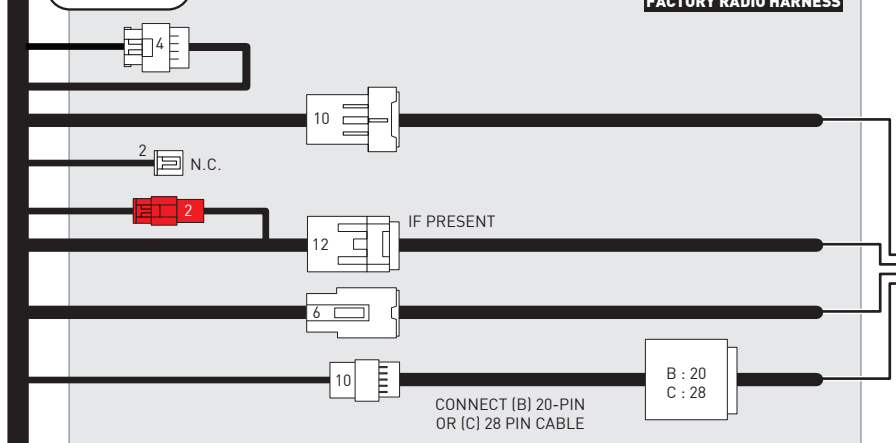

STEP 3

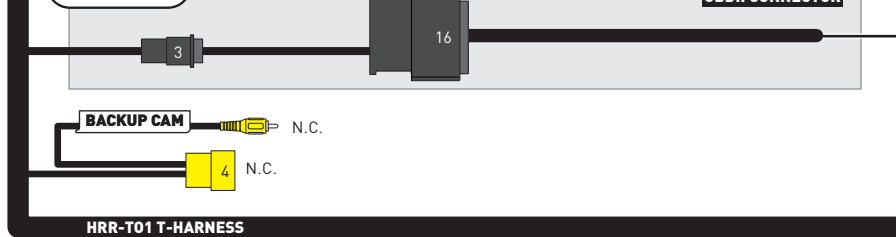

STEP 5

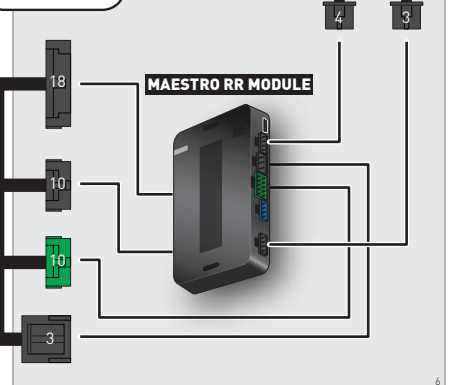

NOT REQUIRED

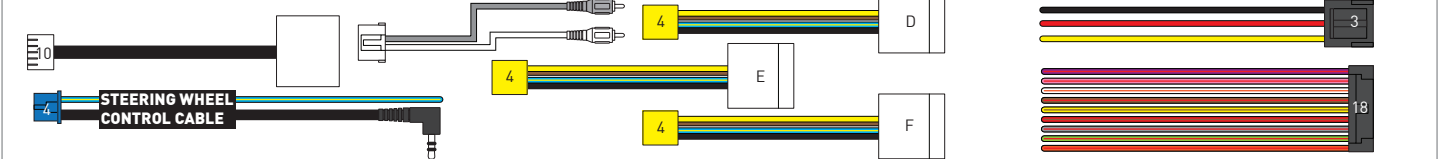

RADIO WIRE REFERENCE CHART

T01 T-harness Wire Description	Polarity	Wire Color on Maestro T-Harness	Wire Color on Alpine cable	Wire Color on Kenwood/JVC cable	Wire Color on Pioneer cable	Wire Color on Sony cable
Illumination	(+)	Orange	N/A	Orange/White	Orange/White	Orange
Reverse Light*	(+)	Purple/White	Orange/White	Purple/White	Purple/White	Purple/White
E-Brake	(-)	Lt Green	Yellow/Blue	Lt Green	Lt Green	Lt Green
VSS (vehicle speed sensor)	(DATA)	Pink	Green/White	Pink	Pink	N/A

Head unit adapter wiring (optional accessory, sold separately)

ACC-HU-ALP1 Wire Description	Polarity	Wire Color on Adapter	Alpine Radio
VSS (vehicle speed sensor)	(DATA)	Green/White	Green/White

ACC-HU-KEN1 Wire Description	Polarity	Wire Color on Adapter	Kenwood Radio
CAM	(+)	Green/Red	Refer to camera/radio manual
CAM	(-)	Green/White	Refer to camera/radio manual
Steering Wheel Controls	(DATA)	Blue/Yellow	n/a

ACC-HU-KEN2 Wire Description	Polarity	Wire Color on Adapter	Kenwood Radio
E-Brake	(-)	LtGreen	LtGreen
Reverse Light*	(+)	Purple/White	Purple/White
Steering Wheel Controls	(DATA)	Blue/Yellow	n/a

* Reverse light wire: Only connect to radio or module damage will occur.

MODULE DIAGNOSTICS



LED 1 Module/Firmware status	LED 2 (RR2) Bluetooth activity	LED STATUS	DIAGNOSTIC
or		RED or GREEN flashing	LED flashes 1 or more times, either red or green, when a steering wheel button is pressed : normal operation.
		1 RED flash	Module has no firmware. Flash module using Weblink Desktop and log in. Do <u>NOT</u> use DEMO MODE.
		2 RED flashes	Problem detected. Consult troubleshooting table.
		1 GREEN flash	After radio boots up : Normal operation.
		3 GREEN flashes	Bluetooth is activated. Turns off after one minute: Normal operation.
		OFF	Normal operation (inactive).

VIDEO HELP		Installation, product information, vehicle specific videos.
VERIFY FLASH		Last flash information, steering control configuration, vehicle information.
WEBLINK		Software to program module.

TROUBLESHOOTING TABLE

PROBLEM	SOLUTION
Gauges do not work, radio shows OBD2 Error 1 or Error 2.	<p>Ensure OBDII connector is securely attached to the OBDII connector of the vehicle.</p> <p>If you hardwired connections at the OBDII, check connections at the OBDII connector. Make sure the RED/BROWN wire is on PIN 6 and the YELLOW/BROWN wire is connected to PIN 14 of the OBDII connector. Do not use T-Taps. Soldering or military splicing methods are recommended.</p> <p>If anything else is connected to the OBD2 or CAN wires of vehicle (programmer, throttle controller, insurance tracker, etc.) try unplugging it to see if gauges work. If gauges work without it installed, call tech support for options.</p> <p>Reset the RR.</p>
The light on the Maestro is blinking RED TWICE and the radio IS turning on.	<p>Ensure the 4-pin data cable is connected between the radio and the RR, and that it is plugged into the black port on the Maestro RR. The red and blue ports on the RR should be empty.</p> <p>Make sure the correct radio model and serial number were entered during the flash. Verify the radio's serial number entered during the flash matches what is listed on the radio screen. This can be found in the settings of the radio, listed as Device Id, Device Number, or Serial Number.</p>
The light on the Maestro is blinking RED TWICE but the radio is NOT turning on.	<p>If installing a modular radio and it is not turning on, ensure the screen is secured and any trim pieces on the radio have been installed fully. Not installing these fully will prevent radio from powering up and show a 2x red error as well.</p> <p>Test red and yellow wires for DC voltage at radio using a multimeter. Contact support if no voltage on red or yellow.</p>
The steering wheel controls are not working, the Maestro RR does not blink when they are pressed.	<p>Ensure the 20 or 28-pin connector is plugged to the vehicle and to the T01 T-harness, as shown in step 3 (this is where the RR gets the steering wheel signal from the vehicle).</p>
(Prius only) After the car is turned off, the radio stays on. The car stays in accessory mode and will not turn off.	<p>Locate the white 12-pin connector of the T01 harness, it is connected to the vehicle harness.</p> <p>Then, cut and isolate the red wire located at pin 11. The radio will shut off when the vehicle is turned off.</p>

MAESTRO RR RESET PROCEDURE:

Turn the key to the OFF position, then disconnect all connectors from the module.

Press and hold the module's programming button and connect all the connectors back to the module. Wait, the module's LED will flash RED rapidly (this may take up to 10 seconds).

Release the programming button. Wait, the LED will turn solid GREEN for 2 seconds to show the reset was successful.

TECHNICAL ASSISTANCE

Phone: 1-866-427-2999

Email: maestro.support@idatalink.com

IMPORTANT: To ensure proper operation, the aftermarket radio needs to have the latest firmware from the manufacturer. Please visit the radio manufacturer's website and look for any updates pertaining to your radio.

RETAINS STEERING WHEEL CONTROLS, FACTORY AMPLIFIER, AND MORE!



PRODUCTS REQUIRED

iDataLink Maestro RR or RR2 Radio Replacement Interface
iDataLink Maestro HRR-T01 Installation Harness

PROGRAMMED FIRMWARE

ADS-RR(SR)-TOY01-DS

ADDITIONAL RESOURCES

[Maestro RR2 Programmable Outputs Guide](#)

OPTIONAL ACCESSORIES

K40[™]
ELECTRONICS
ESCORT

Click here for:
[Radar Installation Guides](#)

HEAD UNIT ADAPTER:
ACC-HU-PI01, SON1, KEN1, KEN2, ALP1

WELCOME

Congratulations on the purchase of your iDatalink Maestro RR Radio replacement solution. You are now a few simple steps away from enjoying your new car radio with enhanced features.

Before starting your installation, please ensure that your iDatalink Maestro module is programmed with the correct firmware for your vehicle and that you carefully review the install guide.

Please note that Maestro RR will only retain functionalities that were originally available in the vehicle.

NEED HELP?

 1 866 427-2999

 maestro.support@idatalink.com

TABLE OF CONTENTS

Installation Instructions	3
Wiring Diagram	4
Radio Wire Reference Chart	5
Module Diagnostics	6
Troubleshooting Table	7

INSTALLATION INSTRUCTIONS P1/1

STEP 1

Remove the factory radio

If using head unit adapter (sold separately), connect HRR-T01 harness to adapter and skip to step 2.

- Unbox the aftermarket radio and locate its main harness.
- Cut and remove the black 20 pin connector from the HRR-T01 T-harness and connect the wires, shown in the wiring diagram, from aftermarket radio main harness to the HRR-T01 T-harness and match the wire functions.

Note: only connect purple/white wire to radio reverse input or module damage will occur.

STEP 2

- Identify if your vehicle has a 20 or 28 pin secondary connector.
- Assemble T01 T-harness as shown on wiring diagram.
- Connect the factory harness to the HRR-T01 harness.

STEP 3

- Connect HRR-T01 3-pin black connector to black connector of OBDII extension harness.
- Plug the OBDII connector into the OBDII of the vehicle.

STEP 4

- Plug the harnesses into the aftermarket radio.
- Plug the Data cable to the data port of the aftermarket radio.
- Insert the Audio cable into the iDatalink 3.5 mm audio jack of the aftermarket radio (if there is no iDatalink audio input, connect to AUX).

Note: On Pioneer radio, ensure that there is nothing plugged into the W/R port.

STEP 5

- Connect all the harnesses to the Maestro RR module then test your installation.

WIRING DIAGRAM *without an Amplifier*

STEP 1

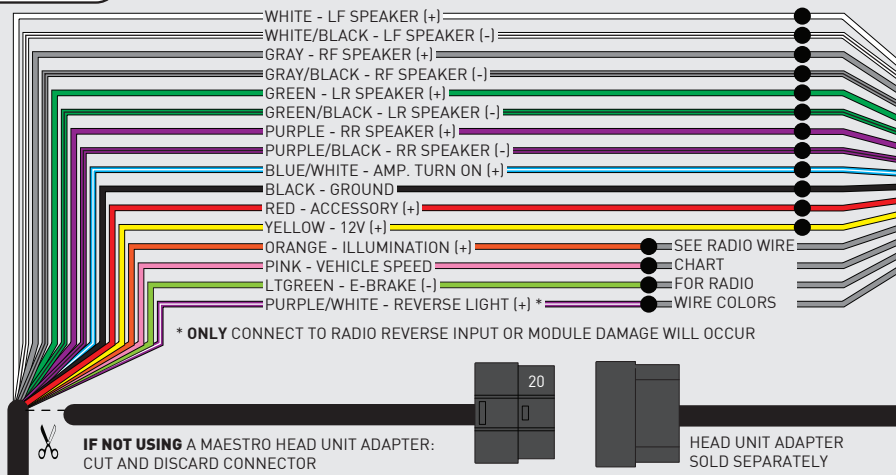

STEP 4

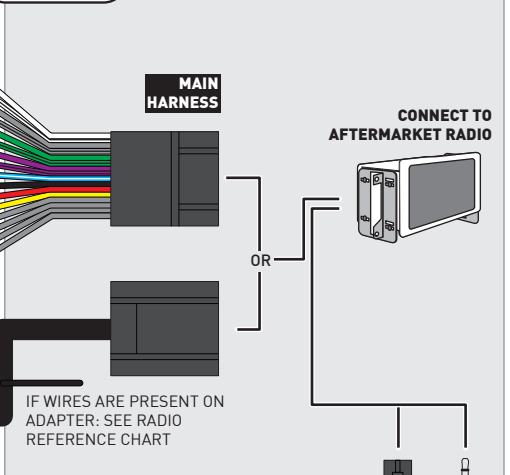

STEP 2

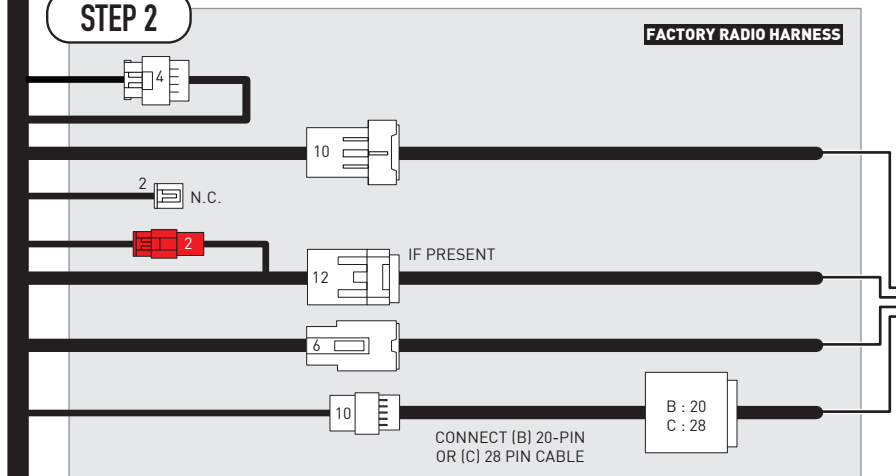

STEP 3

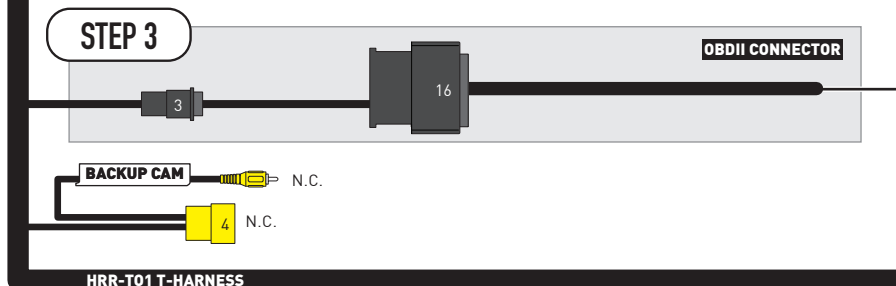

STEP 5

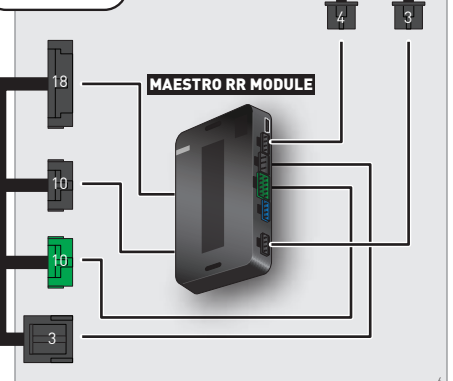

NOT REQUIRED

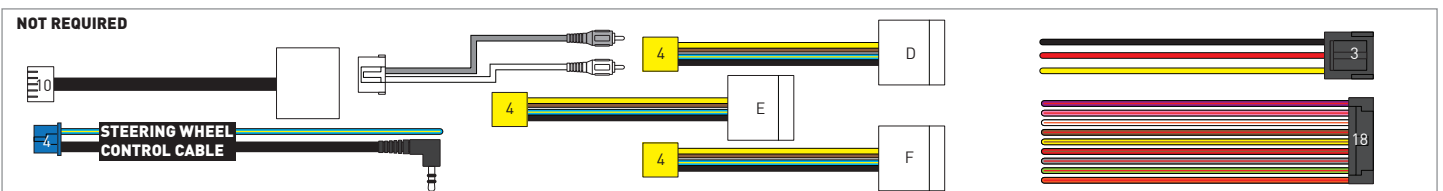

RADIO WIRE REFERENCE CHART

T01 T-harness Wire Description	Polarity	Wire Color on Maestro T-Harness	Wire Color on Alpine cable	Wire Color on Kenwood/ JVC cable	Wire Color on Pioneer cable	Wire Color on Sony cable
Illumination	(+)	Orange	N/A	Orange/White	Orange/White	Orange
Reverse Light*	(+)	Purple/White	Orange/White	Purple/White	Purple/White	Purple/White
E-Brake	(-)	Lt Green	Yellow/Blue	Lt Green	Lt Green	Lt Green
VSS (vehicle speed sensor)	(DATA)	Pink	Green/White	Pink	Pink	N/A

Head unit adapter wiring (optional accessory, sold separately)

ACC-HU-ALP1 Wire Description	Polarity	Wire Color on Adapter	Alpine Radio
VSS (vehicle speed sensor)	(DATA)	Green/White	Green/White

ACC-HU-KEN1 Wire Description	Polarity	Wire Color on Adapter	Kenwood Radio
CAM	(+)	Green/Red	Refer to camera/radio manual
CAM	(-)	Green/White	Refer to camera/radio manual
Steering Wheel Controls	(DATA)	Blue/Yellow	n/a

ACC-HU-KEN2 Wire Description	Polarity	Wire Color on Adapter	Kenwood Radio
E-Brake	(-)	LtGreen	LtGreen
Reverse Light*	(+)	Purple/White	Purple/White
Steering Wheel Controls	(DATA)	Blue/Yellow	n/a

* Reverse light wire: Only connect to radio or module damage will occur.

MODULE DIAGNOSTICS



LED 1 Module/Firmware status	LED 2 (RR2) Bluetooth activity	LED STATUS	DIAGNOSTIC
or		RED or GREEN flashing	LED flashes 1 or more times, either red or green, when a steering wheel button is pressed : normal operation.
		1 RED flash	Module has no firmware. Flash module using Weblink Desktop and log in. Do <u>NOT</u> use DEMO MODE.
		2 RED flashes	Problem detected. Consult troubleshooting table.
		1 GREEN flash	After radio boots up : Normal operation.
		3 GREEN flashes	Bluetooth is activated. Turns off after one minute: Normal operation.
		OFF	Normal operation (inactive).

VIDEO HELP		Installation, product information, vehicle specific videos.
VERIFY FLASH		Last flash information, steering control configuration, vehicle information.
WEBLINK		Software to program module.

TROUBLESHOOTING TABLE

PROBLEM	SOLUTION
Gauges do not work, radio shows OBD2 Error 1 or Error 2.	<p>Ensure OBDII connector is securely attached to the OBDII connector of the vehicle.</p> <p>If you hardwired connections at the OBDII, check connections at the OBDII connector. Make sure the RED/BROWN wire is on PIN 6 and the YELLOW/BROWN wire is connected to PIN 14 of the OBDII connector. Do not use T-Taps. Soldering or military splicing methods are recommended.</p> <p>If anything else is connected to the OBD2 or CAN wires of vehicle (programmer, throttle controller, insurance tracker, etc.) try unplugging it to see if gauges work. If gauges work without it installed, call tech support for options.</p> <p>Reset the RR.</p>
The light on the Maestro is blinking RED TWICE and the radio IS turning on.	<p>Ensure the 4-pin data cable is connected between the radio and the RR, and that it is plugged into the black port on the Maestro RR. The red and blue ports on the RR should be empty.</p> <p>Make sure the correct radio model and serial number were entered during the flash. Verify the radio's serial number entered during the flash matches what is listed on the radio screen. This can be found in the settings of the radio, listed as Device Id, Device Number, or Serial Number.</p>
The light on the Maestro is blinking RED TWICE but the radio is NOT turning on.	<p>If installing a modular radio and it is not turning on, ensure the screen is secured and any trim pieces on the radio have been installed fully. Not installing these fully will prevent radio from powering up and show a 2x red error as well.</p> <p>Test red and yellow wires for DC voltage at radio using a multimeter. Contact support if no voltage on red or yellow.</p>
The steering wheel controls are not working, the Maestro RR does not blink when they are pressed.	<p>Ensure the 20 or 28-pin connector is plugged to the vehicle and to the T01 T-harness, as shown in step 3 (this is where the RR gets the steering wheel signal from the vehicle).</p>
(Prius only) After the car is turned off, the radio stays on. The car stays in accessory mode and will not turn off.	<p>Locate the white 12-pin connector of the T01 harness, it is connected to the vehicle harness.</p> <p>Then, cut and isolate the red wire located at pin 11. The radio will shut off when the vehicle is turned off.</p>

MAESTRO RR RESET PROCEDURE:

Turn the key to the OFF position, then disconnect all connectors from the module.

Press and hold the module's programming button and connect all the connectors back to the module. Wait, the module's LED will flash RED rapidly (this may take up to 10 seconds).

Release the programming button. Wait, the LED will turn solid GREEN for 2 seconds to show the reset was successful.

TECHNICAL ASSISTANCE

Phone: 1-866-427-2999

Email: maestro.support@idatalink.com

IMPORTANT: To ensure proper operation, the aftermarket radio needs to have the latest firmware from the manufacturer. Please visit the radio manufacturer's website and look for any updates pertaining to your radio.

RETAINS STEERING WHEEL CONTROLS, FACTORY AMPLIFIER, AND MORE!



PRODUCTS REQUIRED

iDatalink Maestro RR or RR2 Radio Replacement Interface
iDatalink Maestro HRR-T01 Installation Harness

PROGRAMMED FIRMWARE

ADS-RR(SR)-TOY01-DS

ADDITIONAL RESOURCES

[Maestro RR2 Programmable Outputs Guide](#)

OPTIONAL ACCESSORIES

K40[™]
ELECTRONICS
ESCORT

Click here for:
[Radar Installation Guides](#)

HEAD UNIT ADAPTER:
ACC-HU-PI01, SON1, KEN1, KEN2, ALP1

WELCOME

Congratulations on the purchase of your iDatalink Maestro RR Radio replacement solution. You are now a few simple steps away from enjoying your new car radio with enhanced features.

Before starting your installation, please ensure that your iDatalink Maestro module is programmed with the correct firmware for your vehicle and that you carefully review the install guide.

Please note that Maestro RR will only retain functionalities that were originally available in the vehicle.

NEED HELP?

 1 866 427-2999

 maestro.support@idatalink.com

TABLE OF CONTENTS

Installation Instructions	3
Wiring Diagram	4
Radio Wire Reference Chart	5
Module Diagnostics	6
Troubleshooting Table	7

INSTALLATION INSTRUCTIONS P1/1

STEP 1

Remove the factory radio

If using head unit adapter (sold separately), connect HRR-T01 harness to adapter and skip to step 2.

- Unbox the aftermarket radio and locate its main harness.
- Cut and remove the black 20 pin connector from the HRR-T01 T-harness and connect the wires, shown in the wiring diagram, from aftermarket radio main harness to the HRR-T01 T-harness and match the wire functions.

Note: only connect purple/white wire to radio reverse input or module damage will occur.

STEP 2

- Identify if your vehicle has a 20 or 28 pin secondary connector.
- Assemble T01 T-harness as shown on wiring diagram.
- Connect the factory harness to the HRR-T01 harness.

STEP 3

- Connect HRR-T01 3-pin black connector to black connector of OBDII extension harness.
- Plug the OBDII connector into the OBDII of the vehicle.

STEP 4

- Plug the harnesses into the aftermarket radio.
- Plug the Data cable to the data port of the aftermarket radio.
- Insert the Audio cable into the iDatalink 3.5 mm audio jack of the aftermarket radio (if there is no iDatalink audio input, connect to AUX).

Note: On Pioneer radio, ensure that there is nothing plugged into the W/R port.

STEP 5

- Connect all the harnesses to the Maestro RR module then test your installation.

WIRING DIAGRAM *without an Amplifier*

STEP 1

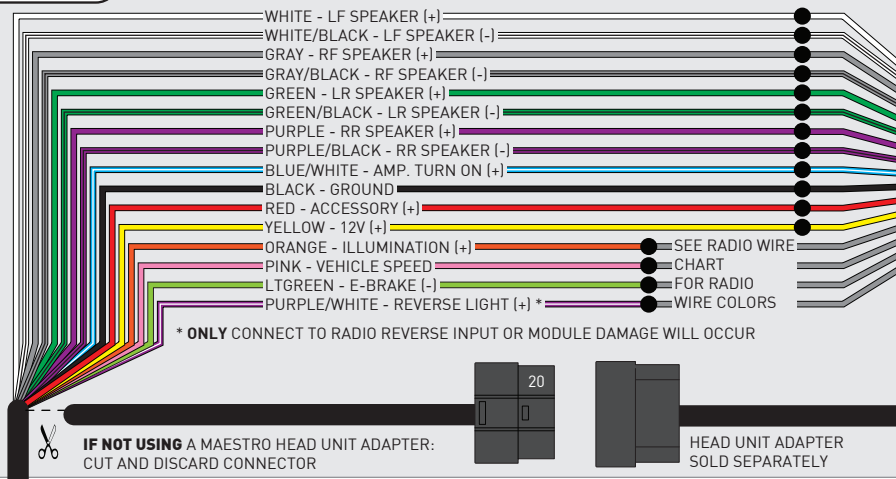

STEP 4

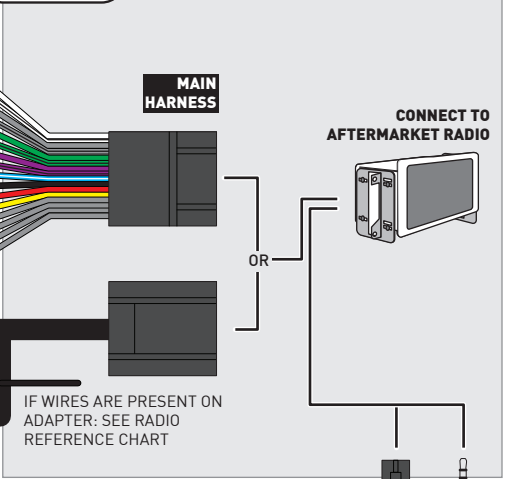

STEP 2

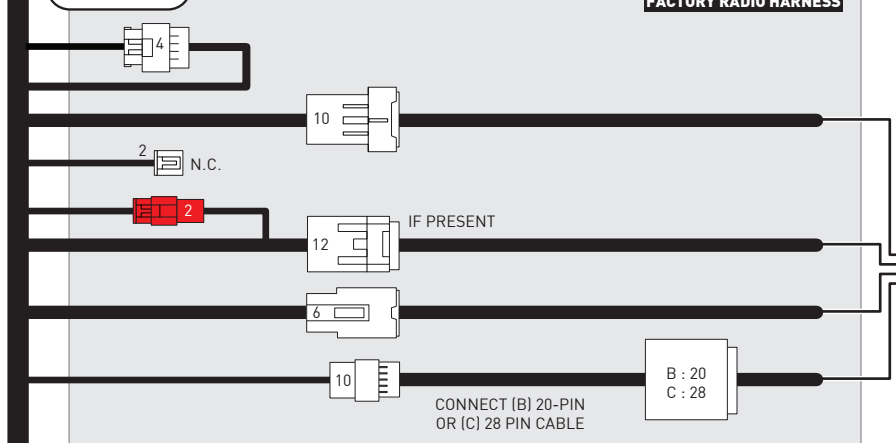

STEP 3

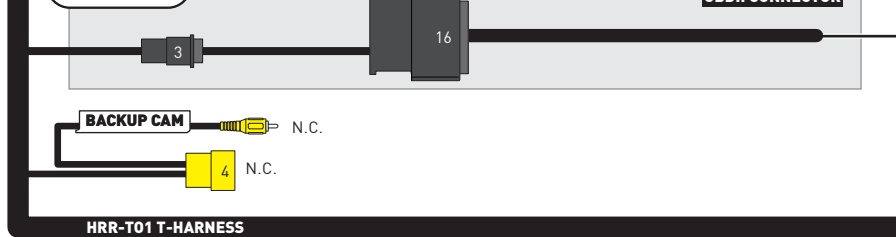

STEP 5

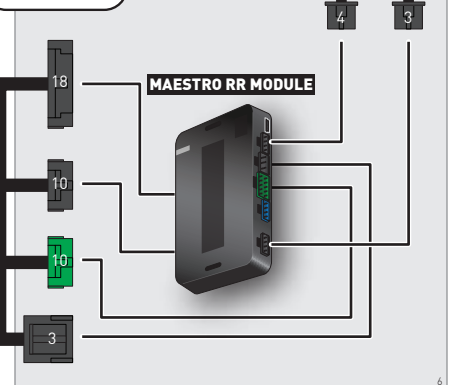

NOT REQUIRED

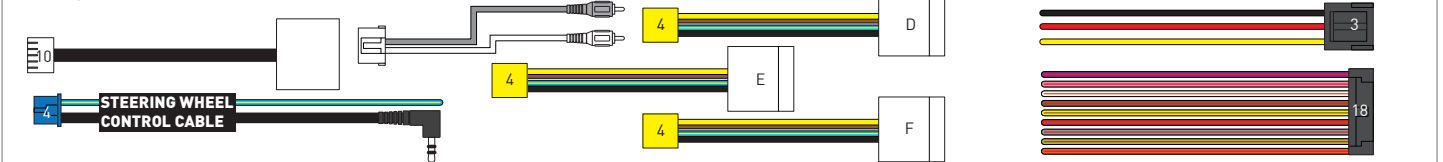

RADIO WIRE REFERENCE CHART

T01 T-harness Wire Description	Polarity	Wire Color on Maestro T-Harness	Wire Color on Alpine cable	Wire Color on Kenwood/ JVC cable	Wire Color on Pioneer cable	Wire Color on Sony cable
Illumination	(+)	Orange	N/A	Orange/White	Orange/White	Orange
Reverse Light*	(+)	Purple/White	Orange/White	Purple/White	Purple/White	Purple/White
E-Brake	(-)	Lt Green	Yellow/Blue	Lt Green	Lt Green	Lt Green
VSS (vehicle speed sensor)	(DATA)	Pink	Green/White	Pink	Pink	N/A

Head unit adapter wiring (optional accessory, sold separately)

ACC-HU-ALP1 Wire Description	Polarity	Wire Color on Adapter	Alpine Radio
VSS (vehicle speed sensor)	(DATA)	Green/White	Green/White

ACC-HU-KEN1 Wire Description	Polarity	Wire Color on Adapter	Kenwood Radio
CAM	(+)	Green/Red	Refer to camera/radio manual
CAM	(-)	Green/White	Refer to camera/radio manual
Steering Wheel Controls	(DATA)	Blue/Yellow	n/a

ACC-HU-KEN2 Wire Description	Polarity	Wire Color on Adapter	Kenwood Radio
E-Brake	(-)	LtGreen	LtGreen
Reverse Light*	(+)	Purple/White	Purple/White
Steering Wheel Controls	(DATA)	Blue/Yellow	n/a

* Reverse light wire: Only connect to radio or module damage will occur.

MODULE DIAGNOSTICS



LED 1 Module/Firmware status	LED 2 (RR2) Bluetooth activity	LED STATUS	DIAGNOSTIC
or		RED or GREEN flashing	LED flashes 1 or more times, either red or green, when a steering wheel button is pressed : normal operation.
		1 RED flash	Module has no firmware. Flash module using Weblink Desktop and log in. Do <u>NOT</u> use DEMO MODE.
		2 RED flashes	Problem detected. Consult troubleshooting table.
		1 GREEN flash	After radio boots up : Normal operation.
		3 GREEN flashes	Bluetooth is activated. Turns off after one minute: Normal operation.
		OFF	Normal operation (inactive).

VIDEO HELP		Installation, product information, vehicle specific videos.
VERIFY FLASH		Last flash information, steering control configuration, vehicle information.
WEBLINK		Software to program module.

TROUBLESHOOTING TABLE

PROBLEM	SOLUTION
Gauges do not work, radio shows OBD2 Error 1 or Error 2.	<p>Ensure OBDII connector is securely attached to the OBDII connector of the vehicle.</p> <p>If you hardwired connections at the OBDII, check connections at the OBDII connector. Make sure the RED/BROWN wire is on PIN 6 and the YELLOW/BROWN wire is connected to PIN 14 of the OBDII connector. Do not use T-Taps. Soldering or military splicing methods are recommended.</p> <p>If anything else is connected to the OBD2 or CAN wires of vehicle (programmer, throttle controller, insurance tracker, etc.) try unplugging it to see if gauges work. If gauges work without it installed, call tech support for options.</p> <p>Reset the RR.</p>
The light on the Maestro is blinking RED TWICE and the radio IS turning on.	<p>Ensure the 4-pin data cable is connected between the radio and the RR, and that it is plugged into the black port on the Maestro RR. The red and blue ports on the RR should be empty.</p> <p>Make sure the correct radio model and serial number were entered during the flash. Verify the radio's serial number entered during the flash matches what is listed on the radio screen. This can be found in the settings of the radio, listed as Device Id, Device Number, or Serial Number.</p>
The light on the Maestro is blinking RED TWICE but the radio is NOT turning on.	<p>If installing a modular radio and it is not turning on, ensure the screen is secured and any trim pieces on the radio have been installed fully. Not installing these fully will prevent radio from powering up and show a 2x red error as well.</p> <p>Test red and yellow wires for DC voltage at radio using a multimeter. Contact support if no voltage on red or yellow.</p>
The steering wheel controls are not working, the Maestro RR does not blink when they are pressed.	<p>Ensure the 20 or 28-pin connector is plugged to the vehicle and to the T01 T-harness, as shown in step 3 (this is where the RR gets the steering wheel signal from the vehicle).</p>
(Prius only) After the car is turned off, the radio stays on. The car stays in accessory mode and will not turn off.	<p>Locate the white 12-pin connector of the T01 harness, it is connected to the vehicle harness.</p> <p>Then, cut and isolate the red wire located at pin 11. The radio will shut off when the vehicle is turned off.</p>

MAESTRO RR RESET PROCEDURE:

Turn the key to the OFF position, then disconnect all connectors from the module.

Press and hold the module's programming button and connect all the connectors back to the module. Wait, the module's LED will flash RED rapidly (this may take up to 10 seconds).

Release the programming button. Wait, the LED will turn solid GREEN for 2 seconds to show the reset was successful.

TECHNICAL ASSISTANCE

Phone: 1-866-427-2999
 Email: maestro.support@idatalink.com

IMPORTANT: To ensure proper operation, the aftermarket radio needs to have the latest firmware from the manufacturer. Please visit the radio manufacturer's website and look for any updates pertaining to your radio.

RETAINS STEERING WHEEL CONTROLS, FACTORY AMPLIFIER, AND MORE!



PRODUCTS REQUIRED

iDatalink Maestro RR or RR2 Radio Replacement Interface
iDatalink Maestro HRR-T01 Installation Harness

PROGRAMMED FIRMWARE

ADS-RR(SR)-TOY01-DS

ADDITIONAL RESOURCES

[Maestro RR2 Programmable Outputs Guide](#)

OPTIONAL ACCESSORIES

K40[™]
ELECTRONICS
ESCORT

Click here for:
[Radar Installation Guides](#)

HEAD UNIT ADAPTER:
ACC-HU-PI01, SON1, KEN1, KEN2, ALP1

WELCOME

Congratulations on the purchase of your iDatalink Maestro RR Radio replacement solution. You are now a few simple steps away from enjoying your new car radio with enhanced features.

Before starting your installation, please ensure that your iDatalink Maestro module is programmed with the correct firmware for your vehicle and that you carefully review the install guide.

Please note that Maestro RR will only retain functionalities that were originally available in the vehicle.

TABLE OF CONTENTS

Installation Instructions	3
Wiring Diagram	4
Radio Wire Reference Chart	5
Module Diagnostics	6
Troubleshooting Table	7

NEED HELP?

 1 866 427-2999

 maestro.support@idatalink.com

INSTALLATION INSTRUCTIONS P1/1

STEP 1

Remove the factory radio

If using head unit adapter (sold separately), connect HRR-T01 harness to adapter and skip to step 2.

- Unbox the aftermarket radio and locate its main harness.
- Cut and remove the black 20 pin connector from the HRR-T01 T-harness and connect the wires, shown in the wiring diagram, from aftermarket radio main harness to the HRR-T01 T-harness and match the wire functions.

Note: only connect purple/white wire to radio reverse input or module damage will occur.

STEP 2

- If the vehicle is equipped with an OEM backup camera, connect the HRR-T01 harness to appropriate HRR adapter cable (D, E or F) then connect to the backup camera harness.

STEP 3

- Identify if your vehicle has a 20 or 28 pin secondary connector.
- Assemble T01 T-harness as shown on wiring diagram.
- Connect the factory harness to the HRR-T01 harness.

STEP 4

- Connect HRR-T01 3-pin black connector to black connector of OBDII extension harness.
- Plug the OBDII connector into the OBDII of the vehicle.

STEP 5

- Plug the harnesses into the aftermarket radio.
- Connect the backup camera RCA cable into the aftermarket radio (if equipped).
- Connect the left front and right front low level outputs RCA cables into the aftermarket radio.
- Plug the Data cable to the data port of the aftermarket radio.
- Insert the Audio cable into the iDatalink 3.5 mm audio jack of the aftermarket radio (if there is no iDatalink audio input, connect to AUX).

Note: On Pioneer radio, ensure that there is nothing plugged into the W/R port.

STEP 6

- Connect all the harnesses to the Maestro RR module then test your installation.

WIRING DIAGRAM *with an Amplifier*

STEP 1

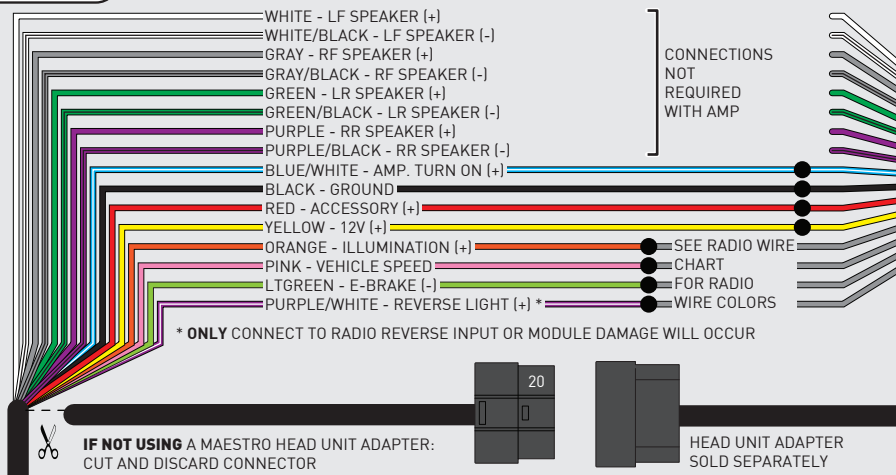

STEP 5

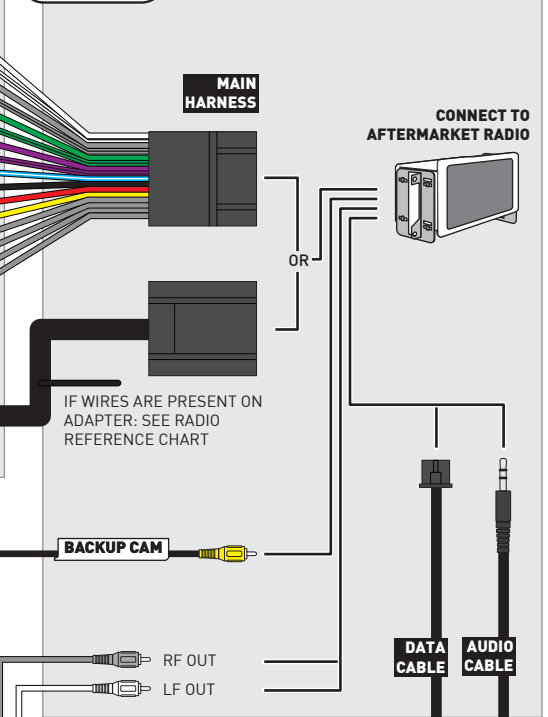

STEP 2

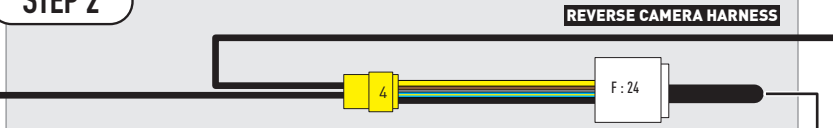

STEP 3

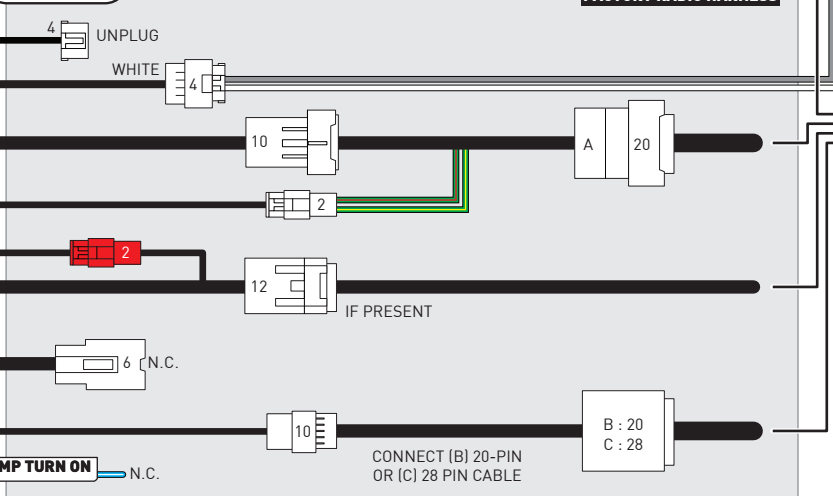

STEP 4

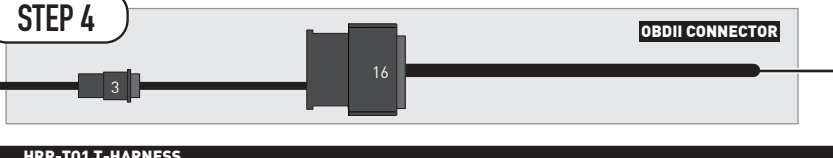

STEP 6

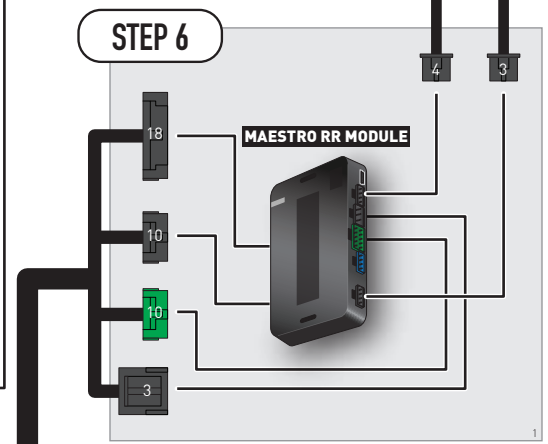

NOT REQUIRED

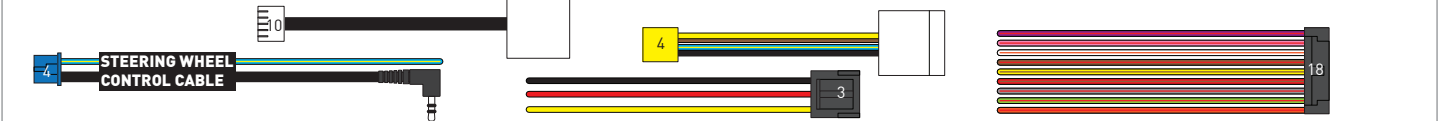

RADIO WIRE REFERENCE CHART

T01 T-harness Wire Description	Polarity	Wire Color on Maestro T-Harness	Wire Color on Alpine cable	Wire Color on Kenwood/JVC cable	Wire Color on Pioneer cable	Wire Color on Sony cable
Illumination	(+)	Orange	N/A	Orange/White	Orange/White	Orange
Reverse Light*	(+)	Purple/White	Orange/White	Purple/White	Purple/White	Purple/White
E-Brake	(-)	Lt Green	Yellow/Blue	Lt Green	Lt Green	Lt Green
VSS (vehicle speed sensor)	(DATA)	Pink	Green/White	Pink	Pink	N/A

Head unit adapter wiring (optional accessory, sold separately)

ACC-HU-ALP1 Wire Description	Polarity	Wire Color on Adapter	Alpine Radio
VSS (vehicle speed sensor)	(DATA)	Green/White	Green/White

ACC-HU-KEN1 Wire Description	Polarity	Wire Color on Adapter	Kenwood Radio
CAM	(+)	Green/Red	Refer to camera/radio manual
CAM	(-)	Green/White	Refer to camera/radio manual
Steering Wheel Controls	(DATA)	Blue/Yellow	n/a

ACC-HU-KEN2 Wire Description	Polarity	Wire Color on Adapter	Kenwood Radio
E-Brake	(-)	LtGreen	LtGreen
Reverse Light*	(+)	Purple/White	Purple/White
Steering Wheel Controls	(DATA)	Blue/Yellow	n/a

* Reverse light wire: Only connect to radio or module damage will occur.

MODULE DIAGNOSTICS



LED 1 Module/Firmware status	LED 2 (RR2) Bluetooth activity	LED STATUS	DIAGNOSTIC
or		RED or GREEN flashing	LED flashes 1 or more times, either red or green, when a steering wheel button is pressed : normal operation.
		1 RED flash	Module has no firmware. Flash module using Weblink Desktop and log in. Do <u>NOT</u> use DEMO MODE.
		2 RED flashes	Problem detected. Consult troubleshooting table.
		1 GREEN flash	After radio boots up : Normal operation.
		3 GREEN flashes	Bluetooth is activated. Turns off after one minute: Normal operation.
		OFF	Normal operation (inactive).

VIDEO HELP		Installation, product information, vehicle specific videos.
VERIFY FLASH		Last flash information, steering control configuration, vehicle information.
WEBLINK		Software to program module.

TROUBLESHOOTING TABLE

PROBLEM	SOLUTION
Gauges do not work, radio shows OBD2 Error 1 or Error 2.	<p>Ensure OBDII connector is securely attached to the OBDII connector of the vehicle.</p> <p>If you hardwired connections at the OBDII, check connections at the OBDII connector. Make sure the RED/BROWN wire is on PIN 6 and the YELLOW/BROWN wire is connected to PIN 14 of the OBDII connector. Do not use T-Taps. Soldering or military splicing methods are recommended.</p> <p>If anything else is connected to the OBD2 or CAN wires of vehicle (programmer, throttle controller, insurance tracker, etc.) try unplugging it to see if gauges work. If gauges work without it installed, call tech support for options.</p> <p>Reset the RR.</p>
The light on the Maestro is blinking RED TWICE and the radio IS turning on.	<p>Ensure the 4-pin data cable is connected between the radio and the RR, and that it is plugged into the black port on the Maestro RR. The red and blue ports on the RR should be empty.</p> <p>Make sure the correct radio model and serial number were entered during the flash. Verify the radio's serial number entered during the flash matches what is listed on the radio screen. This can be found in the settings of the radio, listed as Device Id, Device Number, or Serial Number.</p>
The light on the Maestro is blinking RED TWICE but the radio is NOT turning on.	<p>If installing a modular radio and it is not turning on, ensure the screen is secured and any trim pieces on the radio have been installed fully. Not installing these fully will prevent radio from powering up and show a 2x red error as well.</p> <p>Test red and yellow wires for DC voltage at radio using a multimeter. Contact support if no voltage on red or yellow.</p>
The steering wheel controls are not working, the Maestro RR does not blink when they are pressed.	<p>Ensure the 20 or 28-pin connector is plugged to the vehicle and to the T01 T-harness, as shown in step 3 (this is where the RR gets the steering wheel signal from the vehicle).</p>
(Prius only) After the car is turned off, the radio stays on. The car stays in accessory mode and will not turn off.	<p>Locate the white 12-pin connector of the T01 harness, it is connected to the vehicle harness.</p> <p>Then, cut and isolate the red wire located at pin 11. The radio will shut off when the vehicle is turned off.</p>

MAESTRO RR RESET PROCEDURE:

Turn the key to the OFF position, then disconnect all connectors from the module.

Press and hold the module's programming button and connect all the connectors back to the module. Wait, the module's LED will flash RED rapidly (this may take up to 10 seconds).

Release the programming button. Wait, the LED will turn solid GREEN for 2 seconds to show the reset was successful.

TECHNICAL ASSISTANCE

Phone: 1-866-427-2999

Email: maestro.support@idatalink.com

IMPORTANT: To ensure proper operation, the aftermarket radio needs to have the latest firmware from the manufacturer. Please visit the radio manufacturer's website and look for any updates pertaining to your radio.

RETAINS STEERING WHEEL CONTROLS, FACTORY AMPLIFIER, AND MORE!



PRODUCTS REQUIRED

iDatalink Maestro RR or RR2 Radio Replacement Interface
iDatalink Maestro HRR-T01 Installation Harness

PROGRAMMED FIRMWARE

ADS-RR(SR)-TOY01-DS

ADDITIONAL RESOURCES

[Maestro RR2 Programmable Outputs Guide](#)

OPTIONAL ACCESSORIES

K40[™]
ELECTRONICS
ESCORT

Click here for:
[Radar Installation Guides](#)

HEAD UNIT ADAPTER:
ACC-HU-PI01, SON1, KEN1, KEN2, ALP1

WELCOME

Congratulations on the purchase of your iDatalink Maestro RR Radio replacement solution. You are now a few simple steps away from enjoying your new car radio with enhanced features.

Before starting your installation, please ensure that your iDatalink Maestro module is programmed with the correct firmware for your vehicle and that you carefully review the install guide.

Please note that Maestro RR will only retain functionalities that were originally available in the vehicle.

TABLE OF CONTENTS

Installation Instructions	3
Wiring Diagram	4
Radio Wire Reference Chart	5
Module Diagnostics	6
Troubleshooting Table	7

NEED HELP?

 1 866 427-2999

 maestro.support@idatalink.com

INSTALLATION INSTRUCTIONS P1/1

STEP 1

Remove the factory radio

If using head unit adapter (sold separately), connect HRR-T01 harness to adapter and skip to step 2.

- Unbox the aftermarket radio and locate its main harness.
- Cut and remove the black 20 pin connector from the HRR-T01 T-harness and connect the wires, shown in the wiring diagram, from aftermarket radio main harness to the HRR-T01 T-harness and match the wire functions.

Note: only connect purple/white wire to radio reverse input or module damage will occur.

STEP 2

- If the vehicle is equipped with an OEM backup camera, connect the HRR-T01 harness to appropriate HRR adapter cable (D, E or F) then connect to the backup camera harness.

STEP 3

- Identify if your vehicle has a 20 or 28 pin secondary connector.
- Assemble T01 T-harness as shown on wiring diagram.
- Connect the factory harness to the HRR-T01 harness.

STEP 4

- Connect HRR-T01 3-pin black connector to black connector of OBDII extension harness.
- Plug the OBDII connector into the OBDII of the vehicle.

STEP 5

- Plug the harnesses into the aftermarket radio.
- Connect the backup camera RCA cable into the aftermarket radio (if equipped).
- Connect the left front and right front low level outputs RCA cables into the aftermarket radio.
- Plug the Data cable to the data port of the aftermarket radio.
- Insert the Audio cable into the iDatalink 3.5 mm audio jack of the aftermarket radio (if there is no iDatalink audio input, connect to AUX).

Note: On Pioneer radio, ensure that there is nothing plugged into the W/R port.

STEP 6

- Connect all the harnesses to the Maestro RR module then test your installation.

WIRING DIAGRAM *with an Amplifier*

STEP 1

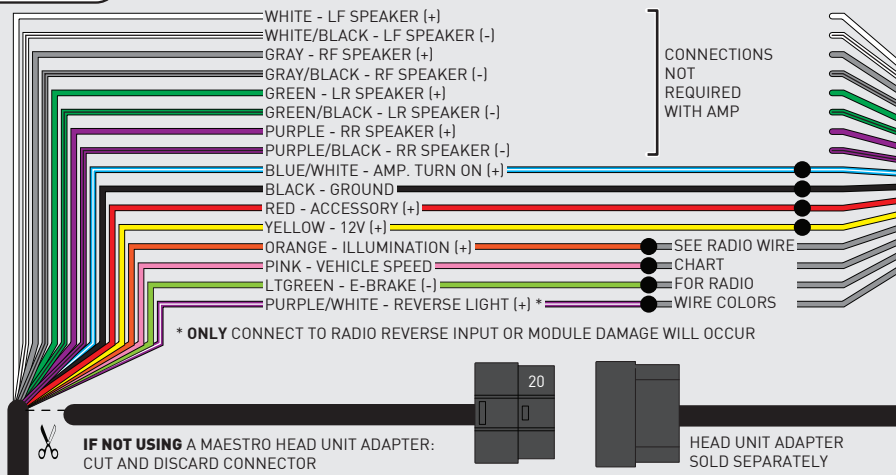

STEP 5

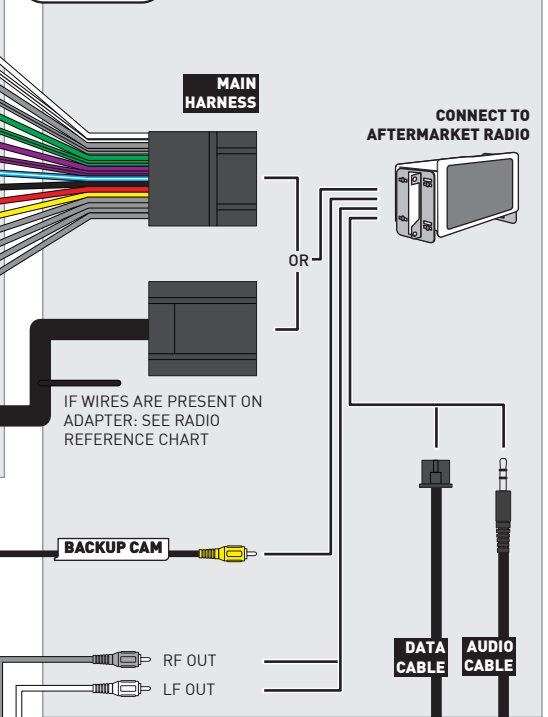

STEP 2

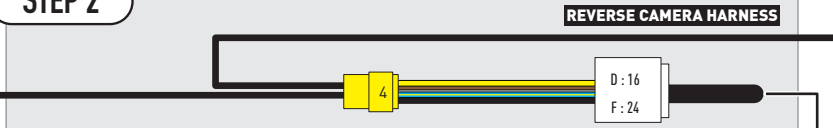

STEP 3

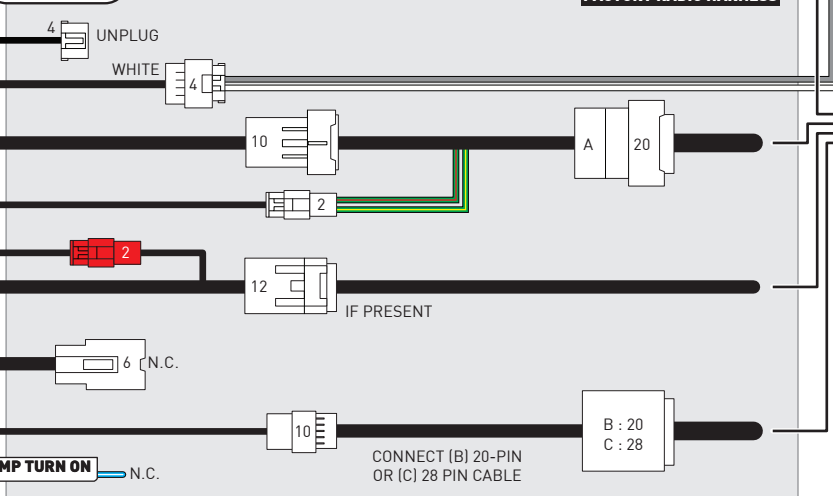

STEP 4



STEP 6

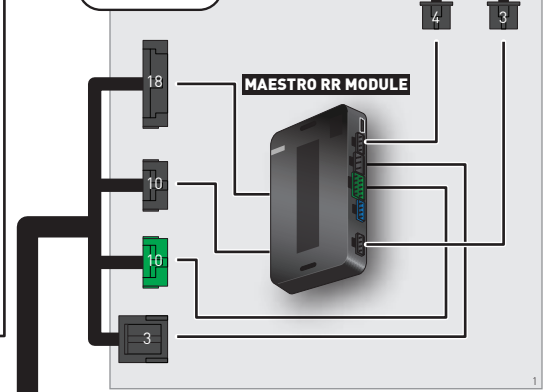

NOT REQUIRED

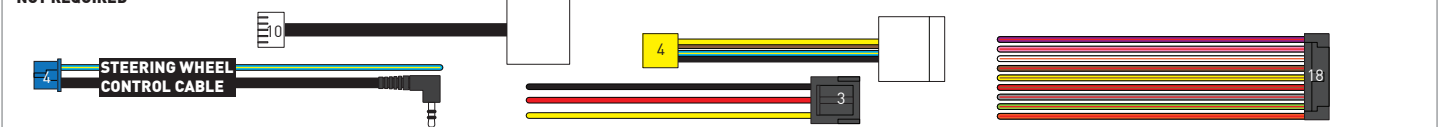

RADIO WIRE REFERENCE CHART

T01 T-harness Wire Description	Polarity	Wire Color on Maestro T-Harness	Wire Color on Alpine cable	Wire Color on Kenwood/JVC cable	Wire Color on Pioneer cable	Wire Color on Sony cable
Illumination	(+)	Orange	N/A	Orange/White	Orange/White	Orange
Reverse Light*	(+)	Purple/White	Orange/White	Purple/White	Purple/White	Purple/White
E-Brake	(-)	Lt Green	Yellow/Blue	Lt Green	Lt Green	Lt Green
VSS (vehicle speed sensor)	(DATA)	Pink	Green/White	Pink	Pink	N/A

Head unit adapter wiring (optional accessory, sold separately)

ACC-HU-ALP1 Wire Description	Polarity	Wire Color on Adapter	Alpine Radio
VSS (vehicle speed sensor)	(DATA)	Green/White	Green/White

ACC-HU-KEN1 Wire Description	Polarity	Wire Color on Adapter	Kenwood Radio
CAM	(+)	Green/Red	Refer to camera/radio manual
CAM	(-)	Green/White	Refer to camera/radio manual
Steering Wheel Controls	(DATA)	Blue/Yellow	n/a

ACC-HU-KEN2 Wire Description	Polarity	Wire Color on Adapter	Kenwood Radio
E-Brake	(-)	LtGreen	LtGreen
Reverse Light*	(+)	Purple/White	Purple/White
Steering Wheel Controls	(DATA)	Blue/Yellow	n/a

* Reverse light wire: Only connect to radio or module damage will occur.

MODULE DIAGNOSTICS



LED 1 Module/Firmware status	LED 2 (RR2) Bluetooth activity	LED STATUS	DIAGNOSTIC
or		RED or GREEN flashing	LED flashes 1 or more times, either red or green, when a steering wheel button is pressed : normal operation.
		1 RED flash	Module has no firmware. Flash module using Weblink Desktop and log in. Do <u>NOT</u> use DEMO MODE.
		2 RED flashes	Problem detected. Consult troubleshooting table.
		1 GREEN flash	After radio boots up : Normal operation.
		3 GREEN flashes	Bluetooth is activated. Turns off after one minute: Normal operation.
		OFF	Normal operation (inactive).

VIDEO HELP		Installation, product information, vehicle specific videos.
VERIFY FLASH		Last flash information, steering control configuration, vehicle information.
WEBLINK		Software to program module.

TROUBLESHOOTING TABLE

PROBLEM	SOLUTION
Gauges do not work, radio shows OBD2 Error 1 or Error 2.	<p>Ensure OBDII connector is securely attached to the OBDII connector of the vehicle.</p> <p>If you hardwired connections at the OBDII, check connections at the OBDII connector. Make sure the RED/BROWN wire is on PIN 6 and the YELLOW/BROWN wire is connected to PIN 14 of the OBDII connector. Do not use T-Taps. Soldering or military splicing methods are recommended.</p> <p>If anything else is connected to the OBD2 or CAN wires of vehicle (programmer, throttle controller, insurance tracker, etc.) try unplugging it to see if gauges work. If gauges work without it installed, call tech support for options.</p> <p>Reset the RR.</p>
The light on the Maestro is blinking RED TWICE and the radio IS turning on.	<p>Ensure the 4-pin data cable is connected between the radio and the RR, and that it is plugged into the black port on the Maestro RR. The red and blue ports on the RR should be empty.</p> <p>Make sure the correct radio model and serial number were entered during the flash. Verify the radio's serial number entered during the flash matches what is listed on the radio screen. This can be found in the settings of the radio, listed as Device Id, Device Number, or Serial Number.</p>
The light on the Maestro is blinking RED TWICE but the radio is NOT turning on.	<p>If installing a modular radio and it is not turning on, ensure the screen is secured and any trim pieces on the radio have been installed fully. Not installing these fully will prevent radio from powering up and show a 2x red error as well.</p> <p>Test red and yellow wires for DC voltage at radio using a multimeter. Contact support if no voltage on red or yellow.</p>
The steering wheel controls are not working, the Maestro RR does not blink when they are pressed.	<p>Ensure the 20 or 28-pin connector is plugged to the vehicle and to the T01 T-harness, as shown in step 3 (this is where the RR gets the steering wheel signal from the vehicle).</p>
(Prius only) After the car is turned off, the radio stays on. The car stays in accessory mode and will not turn off.	<p>Locate the white 12-pin connector of the T01 harness, it is connected to the vehicle harness.</p> <p>Then, cut and isolate the red wire located at pin 11. The radio will shut off when the vehicle is turned off.</p>

MAESTRO RR RESET PROCEDURE:

Turn the key to the OFF position, then disconnect all connectors from the module.

Press and hold the module's programming button and connect all the connectors back to the module. Wait, the module's LED will flash RED rapidly (this may take up to 10 seconds).

Release the programming button. Wait, the LED will turn solid GREEN for 2 seconds to show the reset was successful.

TECHNICAL ASSISTANCE

Phone: 1-866-427-2999

Email: maestro.support@idatalink.com

IMPORTANT: To ensure proper operation, the aftermarket radio needs to have the latest firmware from the manufacturer. Please visit the radio manufacturer's website and look for any updates pertaining to your radio.

RETAINS STEERING WHEEL CONTROLS, FACTORY AMPLIFIER, AND MORE!



PRODUCTS REQUIRED

iDatalink Maestro RR or RR2 Radio Replacement Interface
iDatalink Maestro HRR-T01 Installation Harness

PROGRAMMED FIRMWARE

ADS-RR(SR)-TOY01-DS

ADDITIONAL RESOURCES

[Maestro RR2 Programmable Outputs Guide](#)

OPTIONAL ACCESSORIES

K40[™]
ELECTRONICS
ESCORT

Click here for:
[Radar Installation Guides](#)

HEAD UNIT ADAPTER:
ACC-HU-PI01, SON1, KEN1, KEN2, ALP1

WELCOME

Congratulations on the purchase of your iDatalink Maestro RR Radio replacement solution. You are now a few simple steps away from enjoying your new car radio with enhanced features.

Before starting your installation, please ensure that your iDatalink Maestro module is programmed with the correct firmware for your vehicle and that you carefully review the install guide.

Please note that Maestro RR will only retain functionalities that were originally available in the vehicle.

TABLE OF CONTENTS

Installation Instructions	3
Wiring Diagram	4
Radio Wire Reference Chart	5
Module Diagnostics	6
Troubleshooting Table	7

NEED HELP?

 1 866 427-2999

 maestro.support@idatalink.com

INSTALLATION INSTRUCTIONS P1/1

STEP 1

Remove the factory radio

If using head unit adapter (sold separately), connect HRR-T01 harness to adapter and skip to step 2.

- Unbox the aftermarket radio and locate its main harness.
- Cut and remove the black 20 pin connector from the HRR-T01 T-harness and connect the wires, shown in the wiring diagram, from aftermarket radio main harness to the HRR-T01 T-harness and match the wire functions.

Note: only connect purple/white wire to radio reverse input or module damage will occur.

STEP 2

- Identify if your vehicle has a 20 or 28 pin secondary connector.
- Assemble T01 T-harness as shown on wiring diagram.
- Connect the factory harness to the HRR-T01 harness.

STEP 3

- Connect HRR-T01 3-pin black connector to black connector of OBDII extension harness.
- Plug the OBDII connector into the OBDII of the vehicle.

STEP 4

- Plug the harnesses into the aftermarket radio.
- Plug the Data cable to the data port of the aftermarket radio.
- Insert the Audio cable into the iDatalink 3.5 mm audio jack of the aftermarket radio (if there is no iDatalink audio input, connect to AUX).

Note: On Pioneer radio, ensure that there is nothing plugged into the W/R port.

STEP 5

- Connect all the harnesses to the Maestro RR module then test your installation.

WIRING DIAGRAM *without an Amplifier*

STEP 1

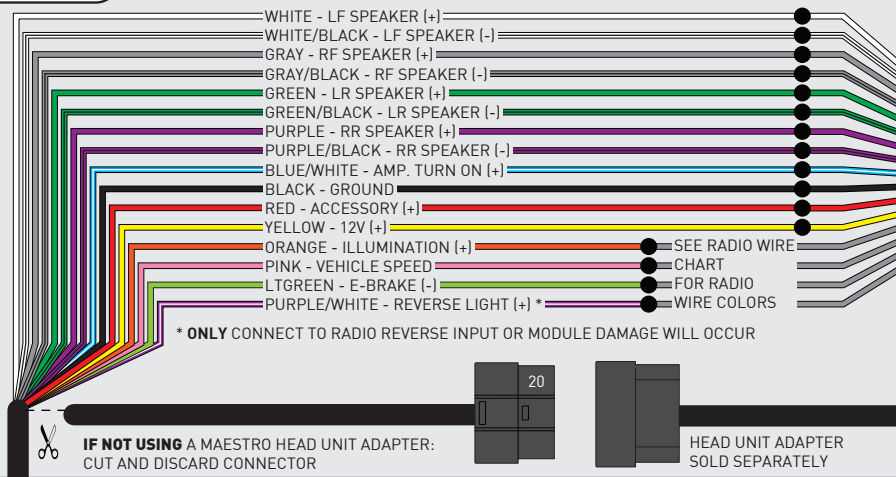

STEP 4

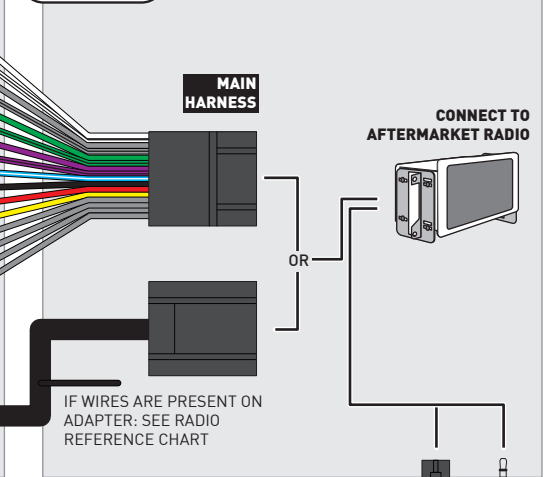

STEP 2

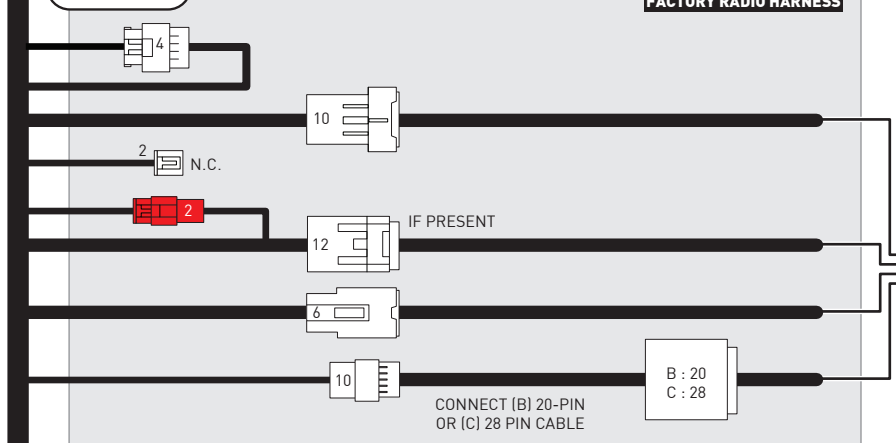

STEP 3

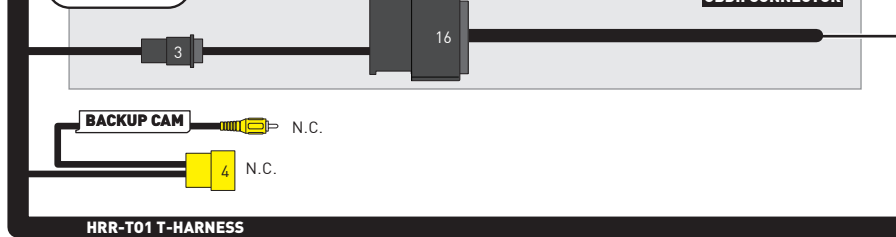

STEP 5

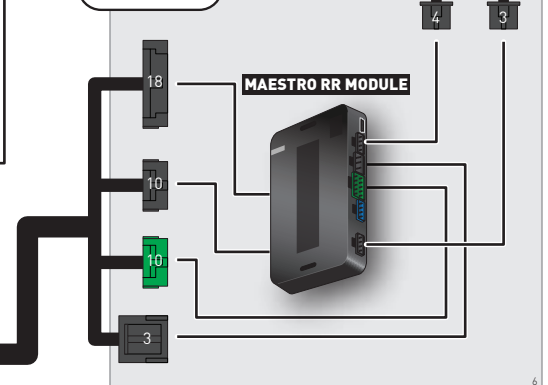

NOT REQUIRED

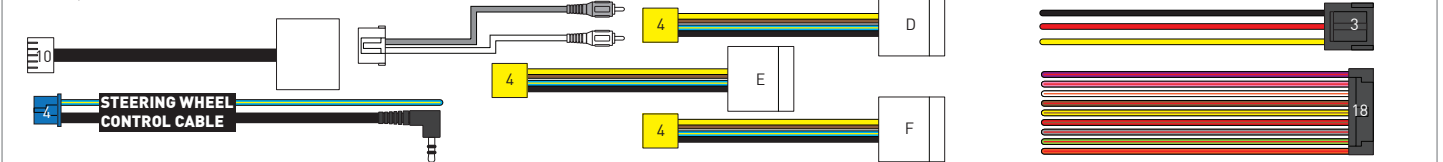

RADIO WIRE REFERENCE CHART

T01 T-harness Wire Description	Polarity	Wire Color on Maestro T-Harness	Wire Color on Alpine cable	Wire Color on Kenwood/ JVC cable	Wire Color on Pioneer cable	Wire Color on Sony cable
Illumination	(+)	Orange	N/A	Orange/White	Orange/White	Orange
Reverse Light*	(+)	Purple/White	Orange/White	Purple/White	Purple/White	Purple/White
E-Brake	(-)	Lt Green	Yellow/Blue	Lt Green	Lt Green	Lt Green
VSS (vehicle speed sensor)	(DATA)	Pink	Green/White	Pink	Pink	N/A

Head unit adapter wiring (optional accessory, sold separately)

ACC-HU-ALP1 Wire Description	Polarity	Wire Color on Adapter	Alpine Radio
VSS (vehicle speed sensor)	(DATA)	Green/White	Green/White

ACC-HU-KEN1 Wire Description	Polarity	Wire Color on Adapter	Kenwood Radio
CAM	(+)	Green/Red	Refer to camera/radio manual
CAM	(-)	Green/White	Refer to camera/radio manual
Steering Wheel Controls	(DATA)	Blue/Yellow	n/a

ACC-HU-KEN2 Wire Description	Polarity	Wire Color on Adapter	Kenwood Radio
E-Brake	(-)	LtGreen	LtGreen
Reverse Light*	(+)	Purple/White	Purple/White
Steering Wheel Controls	(DATA)	Blue/Yellow	n/a

* Reverse light wire: Only connect to radio or module damage will occur.

MODULE DIAGNOSTICS



LED 1 Module/Firmware status	LED 2 (RR2) Bluetooth activity	LED STATUS	DIAGNOSTIC
or		RED or GREEN flashing	LED flashes 1 or more times, either red or green, when a steering wheel button is pressed : normal operation.
		1 RED flash	Module has no firmware. Flash module using Weblink Desktop and log in. Do <u>NOT</u> use DEMO MODE.
		2 RED flashes	Problem detected. Consult troubleshooting table.
		1 GREEN flash	After radio boots up : Normal operation.
		3 GREEN flashes	Bluetooth is activated. Turns off after one minute: Normal operation.
		OFF	Normal operation (inactive).

VIDEO HELP		Installation, product information, vehicle specific videos.
VERIFY FLASH		Last flash information, steering control configuration, vehicle information.
WEBLINK		Software to program module.

TROUBLESHOOTING TABLE

PROBLEM	SOLUTION
Gauges do not work, radio shows OBD2 Error 1 or Error 2.	<p>Ensure OBDII connector is securely attached to the OBDII connector of the vehicle.</p> <p>If you hardwired connections at the OBDII, check connections at the OBDII connector. Make sure the RED/BROWN wire is on PIN 6 and the YELLOW/BROWN wire is connected to PIN 14 of the OBDII connector. Do not use T-Taps. Soldering or military splicing methods are recommended.</p> <p>If anything else is connected to the OBD2 or CAN wires of vehicle (programmer, throttle controller, insurance tracker, etc.) try unplugging it to see if gauges work. If gauges work without it installed, call tech support for options.</p> <p>Reset the RR.</p>
The light on the Maestro is blinking RED TWICE and the radio IS turning on.	<p>Ensure the 4-pin data cable is connected between the radio and the RR, and that it is plugged into the black port on the Maestro RR. The red and blue ports on the RR should be empty.</p> <p>Make sure the correct radio model and serial number were entered during the flash. Verify the radio's serial number entered during the flash matches what is listed on the radio screen. This can be found in the settings of the radio, listed as Device Id, Device Number, or Serial Number.</p>
The light on the Maestro is blinking RED TWICE but the radio is NOT turning on.	<p>If installing a modular radio and it is not turning on, ensure the screen is secured and any trim pieces on the radio have been installed fully. Not installing these fully will prevent radio from powering up and show a 2x red error as well.</p> <p>Test red and yellow wires for DC voltage at radio using a multimeter. Contact support if no voltage on red or yellow.</p>
The steering wheel controls are not working, the Maestro RR does not blink when they are pressed.	<p>Ensure the 20 or 28-pin connector is plugged to the vehicle and to the T01 T-harness, as shown in step 3 (this is where the RR gets the steering wheel signal from the vehicle).</p>
(Prius only) After the car is turned off, the radio stays on. The car stays in accessory mode and will not turn off.	<p>Locate the white 12-pin connector of the T01 harness, it is connected to the vehicle harness.</p> <p>Then, cut and isolate the red wire located at pin 11. The radio will shut off when the vehicle is turned off.</p>

MAESTRO RR RESET PROCEDURE:

Turn the key to the OFF position, then disconnect all connectors from the module.

Press and hold the module's programming button and connect all the connectors back to the module. Wait, the module's LED will flash RED rapidly (this may take up to 10 seconds).

Release the programming button. Wait, the LED will turn solid GREEN for 2 seconds to show the reset was successful.

TECHNICAL ASSISTANCE

Phone: 1-866-427-2999

Email: maestro.support@idatalink.com

IMPORTANT: To ensure proper operation, the aftermarket radio needs to have the latest firmware from the manufacturer. Please visit the radio manufacturer's website and look for any updates pertaining to your radio.

RETAINS STEERING WHEEL CONTROLS, FACTORY AMPLIFIER, AND MORE!



PRODUCTS REQUIRED

iDatalink Maestro RR or RR2 Radio Replacement Interface
iDatalink Maestro HRR-T01 Installation Harness

PROGRAMMED FIRMWARE

ADS-RR(SR)-TOY01-DS

ADDITIONAL RESOURCES

[Maestro RR2 Programmable Outputs Guide](#)

OPTIONAL ACCESSORIES

K40[™]
ELECTRONICS
ESCORT

Click here for:
[Radar Installation Guides](#)

HEAD UNIT ADAPTER:
ACC-HU-PI01, SON1, KEN1, KEN2, ALP1

WELCOME

Congratulations on the purchase of your iDatalink Maestro RR Radio replacement solution. You are now a few simple steps away from enjoying your new car radio with enhanced features.

Before starting your installation, please ensure that your iDatalink Maestro module is programmed with the correct firmware for your vehicle and that you carefully review the install guide.

Please note that Maestro RR will only retain functionalities that were originally available in the vehicle.

TABLE OF CONTENTS

Installation Instructions	3
Wiring Diagram	4
Radio Wire Reference Chart	5
Module Diagnostics	6
Troubleshooting Table	7

NEED HELP?

 1 866 427-2999

 maestro.support@idatalink.com

INSTALLATION INSTRUCTIONS P1/1

STEP 1

Remove the factory radio

If using head unit adapter (sold separately), connect HRR-T01 harness to adapter and skip to step 2.

- Unbox the aftermarket radio and locate its main harness.
- Cut and remove the black 20 pin connector from the HRR-T01 T-harness and connect the wires, shown in the wiring diagram, from aftermarket radio main harness to the HRR-T01 T-harness and match the wire functions.

Note: only connect purple/white wire to radio reverse input or module damage will occur.

STEP 2

- If the vehicle is equipped with an OEM backup camera, connect the HRR-T01 harness to appropriate HRR adapter cable (D, E or F) then connect to the backup camera harness.

STEP 3

- Identify if your vehicle has a 20 or 28 pin secondary connector.
- Assemble T01 T-harness as shown on wiring diagram.
- Connect the factory harness to the HRR-T01 harness.

STEP 4

- Connect HRR-T01 3-pin black connector to black connector of OBDII extension harness.
- Plug the OBDII connector into the OBDII of the vehicle.

STEP 5

- Plug the harnesses into the aftermarket radio.
- Connect the backup camera RCA cable into the aftermarket radio (if equipped).
- Plug the Data cable to the data port of the aftermarket radio.
- Insert the Audio cable into the iDatalink 3.5 mm audio jack of the aftermarket radio (if there is no iDatalink audio input, connect to AUX).

Note: On Pioneer radio, ensure that there is nothing plugged into the W/R port.

STEP 6

- Connect all the harnesses to the Maestro RR module then test your installation.

WIRING DIAGRAM *without an Amplifier*

STEP 1

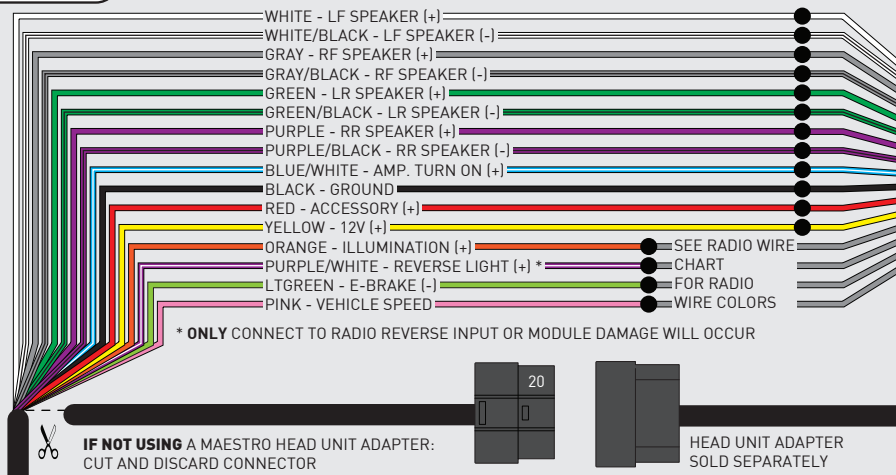

STEP 5

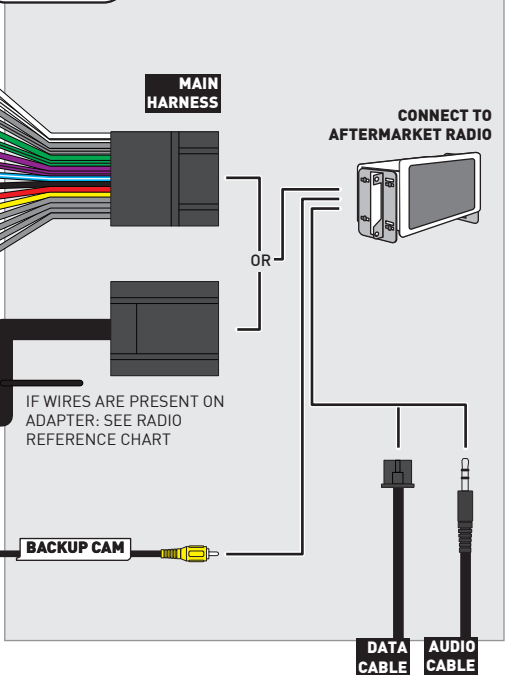

STEP 2

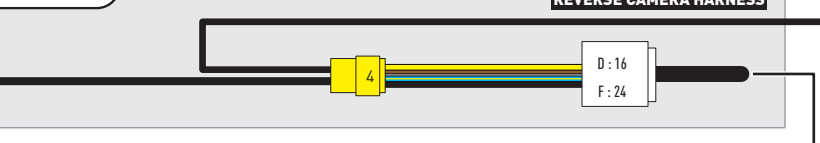

STEP 3

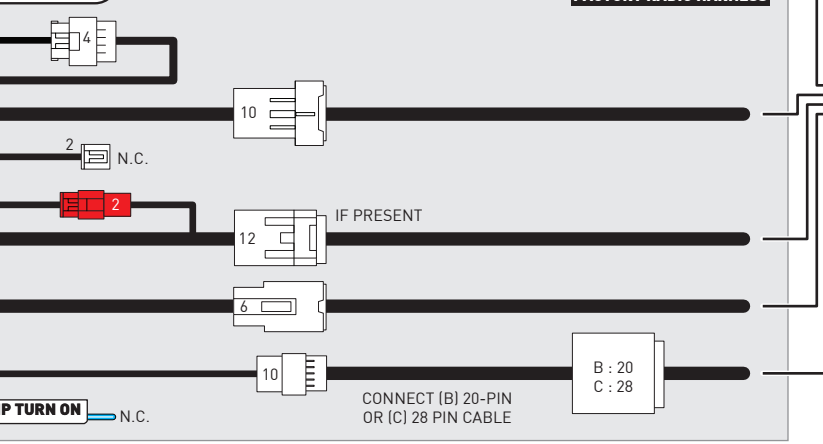

STEP 4



STEP 6

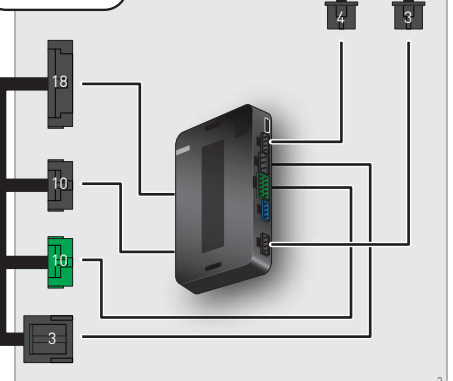

NOT REQUIRED

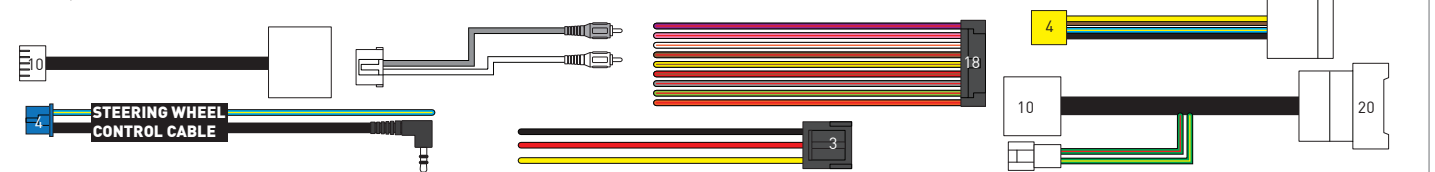

RADIO WIRE REFERENCE CHART

T01 T-harness Wire Description	Polarity	Wire Color on Maestro T-Harness	Wire Color on Alpine cable	Wire Color on Kenwood/ JVC cable	Wire Color on Pioneer cable	Wire Color on Sony cable
Illumination	(+)	Orange	N/A	Orange/White	Orange/White	Orange
Reverse Light*	(+)	Purple/White	Orange/White	Purple/White	Purple/White	Purple/White
E-Brake	(-)	Lt Green	Yellow/Blue	Lt Green	Lt Green	Lt Green
VSS (vehicle speed sensor)	(DATA)	Pink	Green/White	Pink	Pink	N/A

Head unit adapter wiring (optional accessory, sold separately)

ACC-HU-ALP1 Wire Description	Polarity	Wire Color on Adapter	Alpine Radio
VSS (vehicle speed sensor)	(DATA)	Green/White	Green/White

ACC-HU-KEN1 Wire Description	Polarity	Wire Color on Adapter	Kenwood Radio
CAM	(+)	Green/Red	Refer to camera/radio manual
CAM	(-)	Green/White	Refer to camera/radio manual
Steering Wheel Controls	(DATA)	Blue/Yellow	n/a

ACC-HU-KEN2 Wire Description	Polarity	Wire Color on Adapter	Kenwood Radio
E-Brake	(-)	LtGreen	LtGreen
Reverse Light*	(+)	Purple/White	Purple/White
Steering Wheel Controls	(DATA)	Blue/Yellow	n/a

* Reverse light wire: Only connect to radio or module damage will occur.

MODULE DIAGNOSTICS



LED 1 Module/Firmware status	LED 2 (RR2) Bluetooth activity	LED STATUS	DIAGNOSTIC
or		RED or GREEN flashing	LED flashes 1 or more times, either red or green, when a steering wheel button is pressed : normal operation.
		1 RED flash	Module has no firmware. Flash module using Weblink Desktop and log in. Do <u>NOT</u> use DEMO MODE.
		2 RED flashes	Problem detected. Consult troubleshooting table.
		1 GREEN flash	After radio boots up : Normal operation.
		3 GREEN flashes	Bluetooth is activated. Turns off after one minute: Normal operation.
		OFF	Normal operation (inactive).

VIDEO HELP		Installation, product information, vehicle specific videos.
VERIFY FLASH		Last flash information, steering control configuration, vehicle information.
WEBLINK		Software to program module.

TROUBLESHOOTING TABLE

PROBLEM	SOLUTION
Gauges do not work, radio shows OBD2 Error 1 or Error 2.	<p>Ensure OBDII connector is securely attached to the OBDII connector of the vehicle.</p> <p>If you hardwired connections at the OBDII, check connections at the OBDII connector. Make sure the RED/BROWN wire is on PIN 6 and the YELLOW/BROWN wire is connected to PIN 14 of the OBDII connector. Do not use T-Taps. Soldering or military splicing methods are recommended.</p> <p>If anything else is connected to the OBD2 or CAN wires of vehicle (programmer, throttle controller, insurance tracker, etc.) try unplugging it to see if gauges work. If gauges work without it installed, call tech support for options.</p> <p>Reset the RR.</p>
The light on the Maestro is blinking RED TWICE and the radio IS turning on.	<p>Ensure the 4-pin data cable is connected between the radio and the RR, and that it is plugged into the black port on the Maestro RR. The red and blue ports on the RR should be empty.</p> <p>Make sure the correct radio model and serial number were entered during the flash. Verify the radio's serial number entered during the flash matches what is listed on the radio screen. This can be found in the settings of the radio, listed as Device Id, Device Number, or Serial Number.</p>
The light on the Maestro is blinking RED TWICE but the radio is NOT turning on.	<p>If installing a modular radio and it is not turning on, ensure the screen is secured and any trim pieces on the radio have been installed fully. Not installing these fully will prevent radio from powering up and show a 2x red error as well.</p> <p>Test red and yellow wires for DC voltage at radio using a multimeter. Contact support if no voltage on red or yellow.</p>
The steering wheel controls are not working, the Maestro RR does not blink when they are pressed.	<p>Ensure the 20 or 28-pin connector is plugged to the vehicle and to the T01 T-harness, as shown in step 3 (this is where the RR gets the steering wheel signal from the vehicle).</p>
(Prius only) After the car is turned off, the radio stays on. The car stays in accessory mode and will not turn off.	<p>Locate the white 12-pin connector of the T01 harness, it is connected to the vehicle harness.</p> <p>Then, cut and isolate the red wire located at pin 11. The radio will shut off when the vehicle is turned off.</p>

MAESTRO RR RESET PROCEDURE:

Turn the key to the OFF position, then disconnect all connectors from the module.

Press and hold the module's programming button and connect all the connectors back to the module. Wait, the module's LED will flash RED rapidly (this may take up to 10 seconds).

Release the programming button. Wait, the LED will turn solid GREEN for 2 seconds to show the reset was successful.

TECHNICAL ASSISTANCE

Phone: 1-866-427-2999

Email: maestro.support@idatalink.com

IMPORTANT: To ensure proper operation, the aftermarket radio needs to have the latest firmware from the manufacturer. Please visit the radio manufacturer's website and look for any updates pertaining to your radio.

RETAINS STEERING WHEEL CONTROLS, FACTORY AMPLIFIER, AND MORE!



PRODUCTS REQUIRED

iDatalink Maestro RR or RR2 Radio Replacement Interface
iDatalink Maestro HRR-T01 Installation Harness

PROGRAMMED FIRMWARE

ADS-RR(SR)-TOY01-DS

ADDITIONAL RESOURCES

[Maestro RR2 Programmable Outputs Guide](#)

OPTIONAL ACCESSORIES

K40
ELECTRONICS
ESCORT

Click here for:
[Radar Installation Guides](#)

HEAD UNIT ADAPTER:
ACC-HU-PI01, SON1, KEN1, KEN2, ALP1

WELCOME

Congratulations on the purchase of your iDatalink Maestro RR Radio replacement solution. You are now a few simple steps away from enjoying your new car radio with enhanced features.

Before starting your installation, please ensure that your iDatalink Maestro module is programmed with the correct firmware for your vehicle and that you carefully review the install guide.

Please note that Maestro RR will only retain functionalities that were originally available in the vehicle.

NEED HELP?

 1 866 427-2999

 maestro.support@idatalink.com

TABLE OF CONTENTS

Installation Instructions	3
Wiring Diagram	4
Radio Wire Reference Chart	5
Module Diagnostics	6
Troubleshooting Table	7

INSTALLATION INSTRUCTIONS P1/1

STEP 1

Remove the factory radio

If using head unit adapter (sold separately), connect HRR-T01 harness to adapter and skip to step 2.

- Unbox the aftermarket radio and locate its main harness.
- Cut and remove the black 20 pin connector from the HRR-T01 T-harness and connect the wires, shown in the wiring diagram, from aftermarket radio main harness to the HRR-T01 T-harness and match the wire functions.

Note: only connect purple/white wire to radio reverse input or module damage will occur.

STEP 2

- If the vehicle is equipped with an OEM backup camera, connect the HRR-T01 harness to appropriate HRR adapter cable (D, E or F) then connect to the backup camera harness.

STEP 3

- Identify if your vehicle has a 20 or 28 pin secondary connector.
- Assemble T01 T-harness as shown on wiring diagram.
- Connect the factory harness to the HRR-T01 harness.

STEP 4

- Connect HRR-T01 3-pin black connector to black connector of OBDII extension harness.
- Plug the OBDII connector into the OBDII of the vehicle.

STEP 5

- Plug the harnesses into the aftermarket radio.
- Connect the backup camera RCA cable into the aftermarket radio (if equipped).
- Connect the left front and right front low level outputs RCA cables into the aftermarket radio.
- Plug the Data cable to the data port of the aftermarket radio.
- Insert the Audio cable into the iDatalink 3.5 mm audio jack of the aftermarket radio (if there is no iDatalink audio input, connect to AUX).

Note: On Pioneer radio, ensure that there is nothing plugged into the W/R port.

STEP 6

- Connect all the harnesses to the Maestro RR module then test your installation.

WIRING DIAGRAM *with an Amplifier*

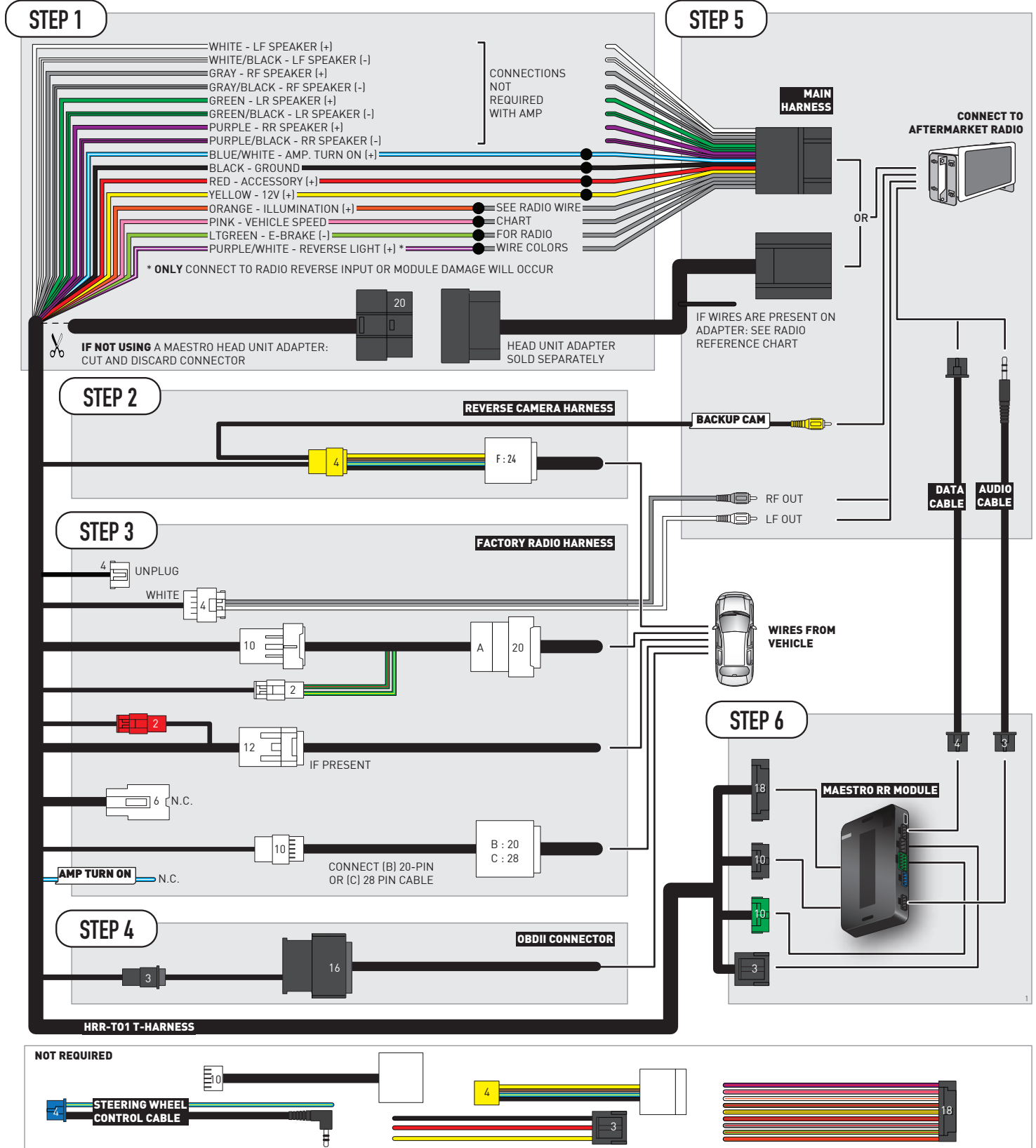

RADIO WIRE REFERENCE CHART

T01 T-harness Wire Description	Polarity	Wire Color on Maestro T-Harness	Wire Color on Alpine cable	Wire Color on Kenwood/JVC cable	Wire Color on Pioneer cable	Wire Color on Sony cable
Illumination	(+)	Orange	N/A	Orange/White	Orange/White	Orange
Reverse Light*	(+)	Purple/White	Orange/White	Purple/White	Purple/White	Purple/White
E-Brake	(-)	Lt Green	Yellow/Blue	Lt Green	Lt Green	Lt Green
VSS (vehicle speed sensor)	(DATA)	Pink	Green/White	Pink	Pink	N/A

Head unit adapter wiring (optional accessory, sold separately)

ACC-HU-ALP1 Wire Description	Polarity	Wire Color on Adapter	Alpine Radio
VSS (vehicle speed sensor)	(DATA)	Green/White	Green/White

ACC-HU-KEN1 Wire Description	Polarity	Wire Color on Adapter	Kenwood Radio
CAM	(+)	Green/Red	Refer to camera/radio manual
CAM	(-)	Green/White	Refer to camera/radio manual
Steering Wheel Controls	(DATA)	Blue/Yellow	n/a

ACC-HU-KEN2 Wire Description	Polarity	Wire Color on Adapter	Kenwood Radio
E-Brake	(-)	LtGreen	LtGreen
Reverse Light*	(+)	Purple/White	Purple/White
Steering Wheel Controls	(DATA)	Blue/Yellow	n/a

* Reverse light wire: Only connect to radio or module damage will occur.

MODULE DIAGNOSTICS



LED 1 Module/Firmware status	LED 2 (RR2) Bluetooth activity	LED STATUS	DIAGNOSTIC
or		RED or GREEN flashing	LED flashes 1 or more times, either red or green, when a steering wheel button is pressed : normal operation.
		1 RED flash	Module has no firmware. Flash module using Weblink Desktop and log in. Do <u>NOT</u> use DEMO MODE.
		2 RED flashes	Problem detected. Consult troubleshooting table.
		1 GREEN flash	After radio boots up : Normal operation.
		3 GREEN flashes	Bluetooth is activated. Turns off after one minute: Normal operation.
		OFF	Normal operation (inactive).

VIDEO HELP		Installation, product information, vehicle specific videos.
VERIFY FLASH		Last flash information, steering control configuration, vehicle information.
WEBLINK		Software to program module.

TROUBLESHOOTING TABLE

PROBLEM	SOLUTION
Gauges do not work, radio shows OBD2 Error 1 or Error 2.	<p>Ensure OBDII connector is securely attached to the OBDII connector of the vehicle.</p> <p>If you hardwired connections at the OBDII, check connections at the OBDII connector. Make sure the RED/BROWN wire is on PIN 6 and the YELLOW/BROWN wire is connected to PIN 14 of the OBDII connector. Do not use T-Taps. Soldering or military splicing methods are recommended.</p> <p>If anything else is connected to the OBD2 or CAN wires of vehicle (programmer, throttle controller, insurance tracker, etc.) try unplugging it to see if gauges work. If gauges work without it installed, call tech support for options.</p> <p>Reset the RR.</p>
The light on the Maestro is blinking RED TWICE and the radio IS turning on.	<p>Ensure the 4-pin data cable is connected between the radio and the RR, and that it is plugged into the black port on the Maestro RR. The red and blue ports on the RR should be empty.</p> <p>Make sure the correct radio model and serial number were entered during the flash. Verify the radio's serial number entered during the flash matches what is listed on the radio screen. This can be found in the settings of the radio, listed as Device Id, Device Number, or Serial Number.</p>
The light on the Maestro is blinking RED TWICE but the radio is NOT turning on.	<p>If installing a modular radio and it is not turning on, ensure the screen is secured and any trim pieces on the radio have been installed fully. Not installing these fully will prevent radio from powering up and show a 2x red error as well.</p> <p>Test red and yellow wires for DC voltage at radio using a multimeter. Contact support if no voltage on red or yellow.</p>
The steering wheel controls are not working, the Maestro RR does not blink when they are pressed.	<p>Ensure the 20 or 28-pin connector is plugged to the vehicle and to the T01 T-harness, as shown in step 3 (this is where the RR gets the steering wheel signal from the vehicle).</p>
(Prius only) After the car is turned off, the radio stays on. The car stays in accessory mode and will not turn off.	<p>Locate the white 12-pin connector of the T01 harness, it is connected to the vehicle harness.</p> <p>Then, cut and isolate the red wire located at pin 11. The radio will shut off when the vehicle is turned off.</p>

MAESTRO RR RESET PROCEDURE:

Turn the key to the OFF position, then disconnect all connectors from the module.

Press and hold the module's programming button and connect all the connectors back to the module. Wait, the module's LED will flash RED rapidly (this may take up to 10 seconds).

Release the programming button. Wait, the LED will turn solid GREEN for 2 seconds to show the reset was successful.

TECHNICAL ASSISTANCE

Phone: 1-866-427-2999

Email: maestro.support@idatalink.com

IMPORTANT: To ensure proper operation, the aftermarket radio needs to have the latest firmware from the manufacturer. Please visit the radio manufacturer's website and look for any updates pertaining to your radio.

RETAINS STEERING WHEEL CONTROLS, FACTORY AMPLIFIER, AND MORE!



PRODUCTS REQUIRED

iDatalink Maestro RR or RR2 Radio Replacement Interface
iDatalink Maestro HRR-T01 Installation Harness

PROGRAMMED FIRMWARE

ADS-RR(SR)-TOY01-DS

ADDITIONAL RESOURCES

[Maestro RR2 Programmable Outputs Guide](#)

OPTIONAL ACCESSORIES

K40[™]
ELECTRONICS
ESCORT

Click here for:
[Radar Installation Guides](#)

HEAD UNIT ADAPTER:
ACC-HU-PI01, SON1, KEN1, KEN2, ALP1

WELCOME

Congratulations on the purchase of your iDatalink Maestro RR Radio replacement solution. You are now a few simple steps away from enjoying your new car radio with enhanced features.

Before starting your installation, please ensure that your iDatalink Maestro module is programmed with the correct firmware for your vehicle and that you carefully review the install guide.

Please note that Maestro RR will only retain functionalities that were originally available in the vehicle.

TABLE OF CONTENTS

Installation Instructions	3
Wiring Diagram	4
Radio Wire Reference Chart	5
Module Diagnostics	6
Troubleshooting Table	7

NEED HELP?

 1 866 427-2999

 maestro.support@idatalink.com

INSTALLATION INSTRUCTIONS P1/1

STEP 1

Remove the factory radio

If using head unit adapter (sold separately), connect HRR-T01 harness to adapter and skip to step 2.

- Unbox the aftermarket radio and locate its main harness.
- Cut and remove the black 20 pin connector from the HRR-T01 T-harness and connect the wires, shown in the wiring diagram, from aftermarket radio main harness to the HRR-T01 T-harness and match the wire functions.

Note: only connect purple/white wire to radio reverse input or module damage will occur.

STEP 2

- If the vehicle is equipped with an OEM backup camera, connect the HRR-T01 harness to appropriate HRR adapter cable (D, E or F) then connect to the backup camera harness.

STEP 3

- Identify if your vehicle has a 20 or 28 pin secondary connector.
- Assemble T01 T-harness as shown on wiring diagram.
- Connect the factory harness to the HRR-T01 harness.

STEP 4

- Connect HRR-T01 3-pin black connector to black connector of OBDII extension harness.
- Plug the OBDII connector into the OBDII of the vehicle.

STEP 5

- Plug the harnesses into the aftermarket radio.
- Connect the backup camera RCA cable into the aftermarket radio (if equipped).
- Connect the left front and right front low level outputs RCA cables into the aftermarket radio.
- Plug the Data cable to the data port of the aftermarket radio.
- Insert the Audio cable into the iDatalink 3.5 mm audio jack of the aftermarket radio (if there is no iDatalink audio input, connect to AUX).

Note: On Pioneer radio, ensure that there is nothing plugged into the W/R port.

STEP 6

- Connect all the harnesses to the Maestro RR module then test your installation.

WIRING DIAGRAM *with an Amplifier*

STEP 1

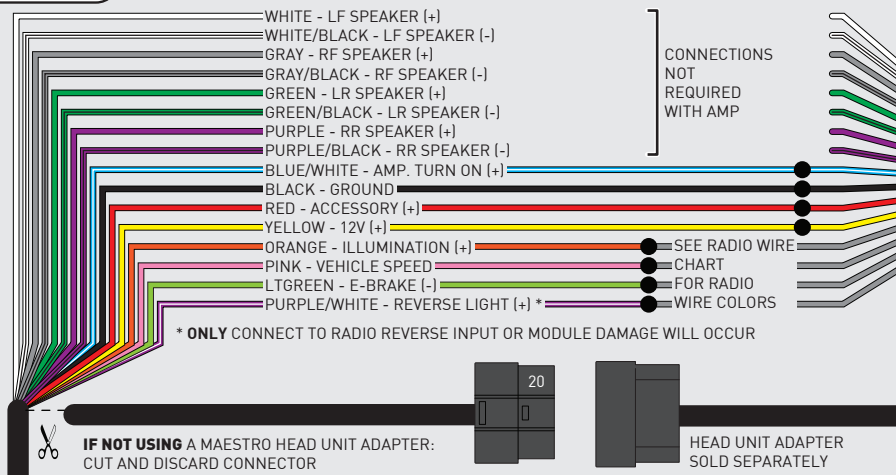

STEP 5

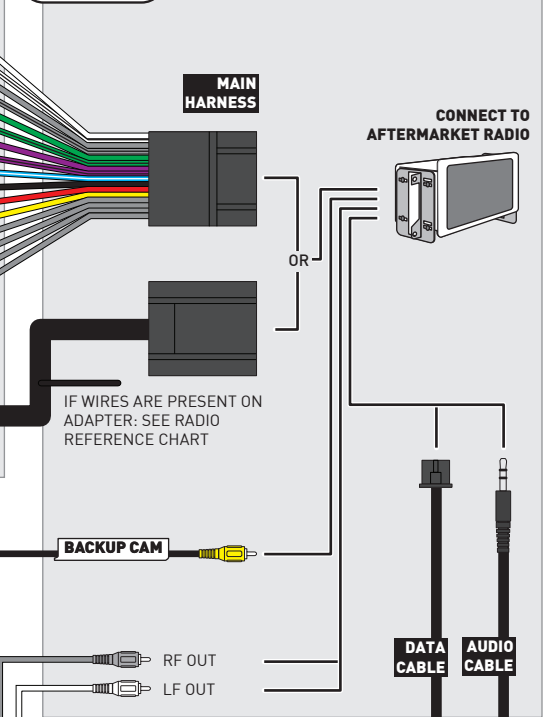

STEP 2

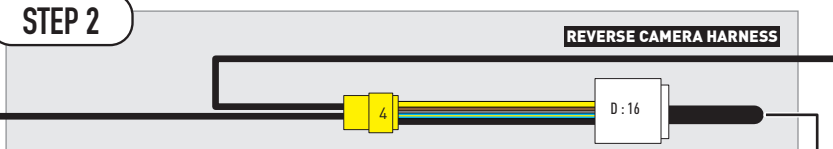

STEP 3

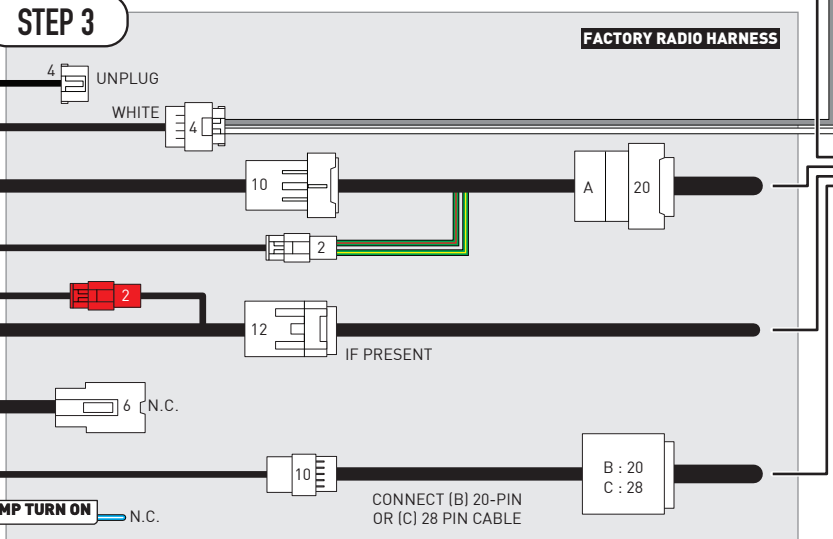

STEP 4

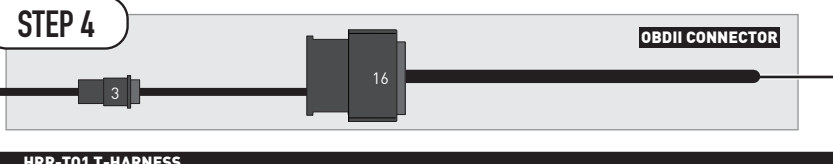

STEP 6

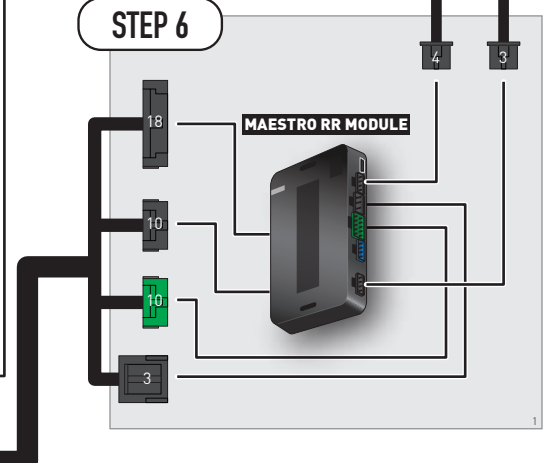

NOT REQUIRED

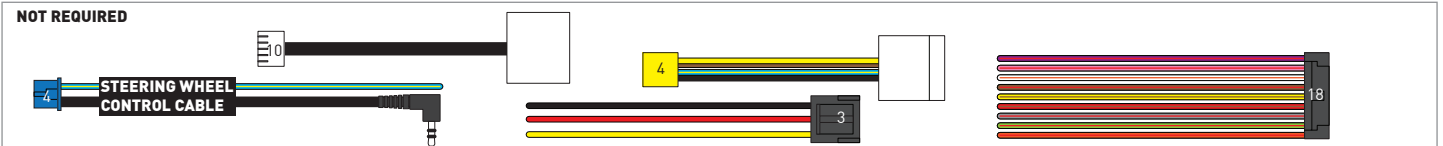

RADIO WIRE REFERENCE CHART

T01 T-harness Wire Description	Polarity	Wire Color on Maestro T-Harness	Wire Color on Alpine cable	Wire Color on Kenwood/JVC cable	Wire Color on Pioneer cable	Wire Color on Sony cable
Illumination	(+)	Orange	N/A	Orange/White	Orange/White	Orange
Reverse Light*	(+)	Purple/White	Orange/White	Purple/White	Purple/White	Purple/White
E-Brake	(-)	Lt Green	Yellow/Blue	Lt Green	Lt Green	Lt Green
VSS (vehicle speed sensor)	(DATA)	Pink	Green/White	Pink	Pink	N/A

Head unit adapter wiring (optional accessory, sold separately)

ACC-HU-ALP1 Wire Description	Polarity	Wire Color on Adapter	Alpine Radio
VSS (vehicle speed sensor)	(DATA)	Green/White	Green/White









ACC-HU-KEN1 Wire Description	Polarity	Wire Color on Adapter	Kenwood Radio
CAM	(+)	Green/Red	Refer to camera/radio manual
CAM	(-)	Green/White	Refer to camera/radio manual
Steering Wheel Controls	(DATA)	Blue/Yellow	n/a

ACC-HU-KEN2 Wire Description	Polarity	Wire Color on Adapter	Kenwood Radio
E-Brake	(-)	LtGreen	LtGreen
Reverse Light*	(+)	Purple/White	Purple/White
Steering Wheel Controls	(DATA)	Blue/Yellow	n/a

* Reverse light wire: Only connect to radio or module damage will occur.

MODULE DIAGNOSTICS



LED 1 Module/Firmware status	LED 2 (RR2) Bluetooth activity	LED STATUS	DIAGNOSTIC
 or 		RED or GREEN flashing	LED flashes 1 or more times, either red or green, when a steering wheel button is pressed : normal operation.
		1 RED flash	Module has no firmware. Flash module using Weblink Desktop and log in. Do <u>NOT</u> use DEMO MODE.
		2 RED flashes	Problem detected. Consult troubleshooting table.
		1 GREEN flash	After radio boots up : Normal operation.
		3 GREEN flashes	Bluetooth is activated. Turns off after one minute: Normal operation.
		OFF	Normal operation (inactive).

VIDEO HELP		Installation, product information, vehicle specific videos.
VERIFY FLASH		Last flash information, steering control configuration, vehicle information.
WEBLINK		Software to program module.

TROUBLESHOOTING TABLE

PROBLEM	SOLUTION
Gauges do not work, radio shows OBD2 Error 1 or Error 2.	<p>Ensure OBDII connector is securely attached to the OBDII connector of the vehicle.</p> <p>If you hardwired connections at the OBDII, check connections at the OBDII connector. Make sure the RED/BROWN wire is on PIN 6 and the YELLOW/BROWN wire is connected to PIN 14 of the OBDII connector. Do not use T-Taps. Soldering or military splicing methods are recommended.</p> <p>If anything else is connected to the OBD2 or CAN wires of vehicle (programmer, throttle controller, insurance tracker, etc.) try unplugging it to see if gauges work. If gauges work without it installed, call tech support for options.</p> <p>Reset the RR.</p>
The light on the Maestro is blinking RED TWICE and the radio IS turning on.	<p>Ensure the 4-pin data cable is connected between the radio and the RR, and that it is plugged into the black port on the Maestro RR. The red and blue ports on the RR should be empty.</p> <p>Make sure the correct radio model and serial number were entered during the flash. Verify the radio's serial number entered during the flash matches what is listed on the radio screen. This can be found in the settings of the radio, listed as Device Id, Device Number, or Serial Number.</p>
The light on the Maestro is blinking RED TWICE but the radio is NOT turning on.	<p>If installing a modular radio and it is not turning on, ensure the screen is secured and any trim pieces on the radio have been installed fully. Not installing these fully will prevent radio from powering up and show a 2x red error as well.</p> <p>Test red and yellow wires for DC voltage at radio using a multimeter. Contact support if no voltage on red or yellow.</p>
The steering wheel controls are not working, the Maestro RR does not blink when they are pressed.	<p>Ensure the 20 or 28-pin connector is plugged to the vehicle and to the T01 T-harness, as shown in step 3 (this is where the RR gets the steering wheel signal from the vehicle).</p>
(Prius only) After the car is turned off, the radio stays on. The car stays in accessory mode and will not turn off.	<p>Locate the white 12-pin connector of the T01 harness, it is connected to the vehicle harness.</p> <p>Then, cut and isolate the red wire located at pin 11. The radio will shut off when the vehicle is turned off.</p>

MAESTRO RR RESET PROCEDURE:

Turn the key to the OFF position, then disconnect all connectors from the module.

Press and hold the module's programming button and connect all the connectors back to the module. Wait, the module's LED will flash RED rapidly (this may take up to 10 seconds).

Release the programming button. Wait, the LED will turn solid GREEN for 2 seconds to show the reset was successful.

TECHNICAL ASSISTANCE

Phone: 1-866-427-2999

Email: maestro.support@idatalink.com

IMPORTANT: To ensure proper operation, the aftermarket radio needs to have the latest firmware from the manufacturer. Please visit the radio manufacturer's website and look for any updates pertaining to your radio.

RETAINS STEERING WHEEL CONTROLS, FACTORY AMPLIFIER, AND MORE!



PRODUCTS REQUIRED

iDatalink Maestro RR or RR2 Radio Replacement Interface
iDatalink Maestro HRR-T01 Installation Harness

PROGRAMMED FIRMWARE

ADS-RR(SR)-TOY01-DS

ADDITIONAL RESOURCES

[Maestro RR2 Programmable Outputs Guide](#)

OPTIONAL ACCESSORIES

K40[™]
ELECTRONICS
ESCORT

Click here for:
[Radar Installation Guides](#)

HEAD UNIT ADAPTER:
ACC-HU-PI01, SON1, KEN1, KEN2, ALP1

WELCOME

Congratulations on the purchase of your iDatalink Maestro RR Radio replacement solution. You are now a few simple steps away from enjoying your new car radio with enhanced features.

Before starting your installation, please ensure that your iDatalink Maestro module is programmed with the correct firmware for your vehicle and that you carefully review the install guide.

Please note that Maestro RR will only retain functionalities that were originally available in the vehicle.

TABLE OF CONTENTS

Installation Instructions	3
Wiring Diagram	4
Radio Wire Reference Chart	5
Module Diagnostics	6
Troubleshooting Table	7

NEED HELP?

 1 866 427-2999

 maestro.support@idatalink.com

INSTALLATION INSTRUCTIONS P1/1

STEP 1

Remove the factory radio

If using head unit adapter (sold separately), connect HRR-T01 harness to adapter and skip to step 2.

- Unbox the aftermarket radio and locate its main harness.
- Cut and remove the black 20 pin connector from the HRR-T01 T-harness and connect the wires, shown in the wiring diagram, from aftermarket radio main harness to the HRR-T01 T-harness and match the wire functions.

Note: only connect purple/white wire to radio reverse input or module damage will occur.

STEP 2

- If the vehicle is equipped with an OEM backup camera, connect the HRR-T01 harness to appropriate HRR adapter cable (D, E or F) then connect to the backup camera harness.

STEP 3

- Identify if your vehicle has a 20 or 28 pin secondary connector.
- Assemble T01 T-harness as shown on wiring diagram.
- Connect the factory harness to the HRR-T01 harness.

STEP 4

- Connect HRR-T01 3-pin black connector to black connector of OBDII extension harness.
- Plug the OBDII connector into the OBDII of the vehicle.

STEP 5

- Plug the harnesses into the aftermarket radio.
- Connect the backup camera RCA cable into the aftermarket radio (if equipped).
- Plug the Data cable to the data port of the aftermarket radio.
- Insert the Audio cable into the iDatalink 3.5 mm audio jack of the aftermarket radio (if there is no iDatalink audio input, connect to AUX).

Note: On Pioneer radio, ensure that there is nothing plugged into the W/R port.

STEP 6

- Connect all the harnesses to the Maestro RR module then test your installation.

WIRING DIAGRAM *without an Amplifier*

STEP 1

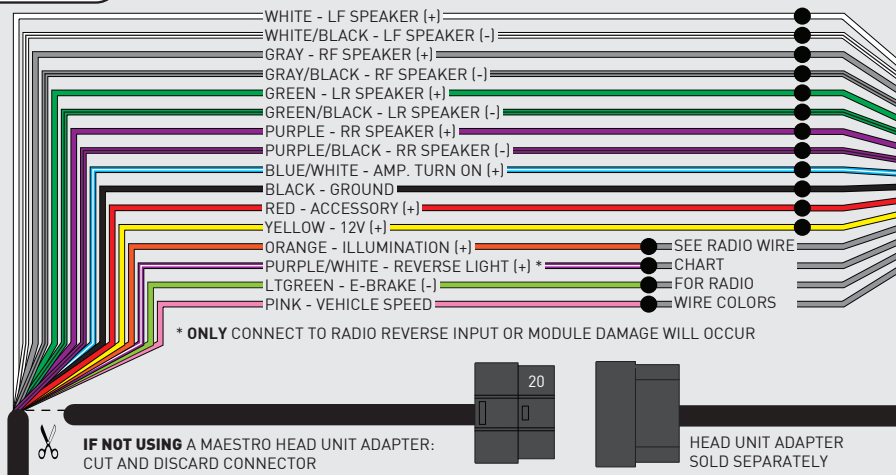

STEP 5

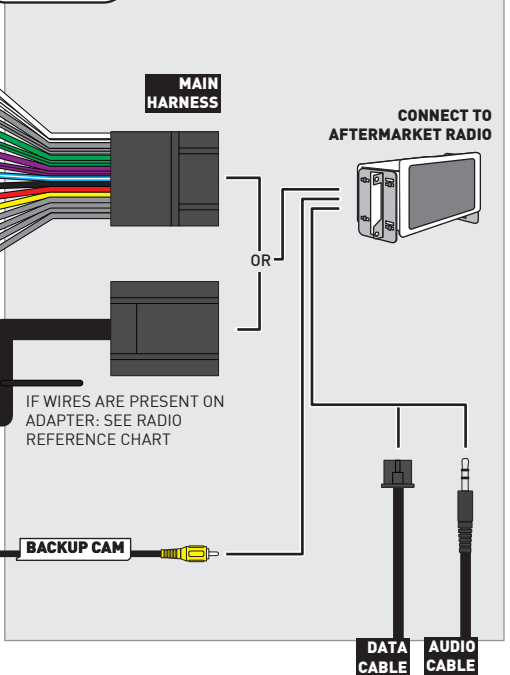

STEP 2

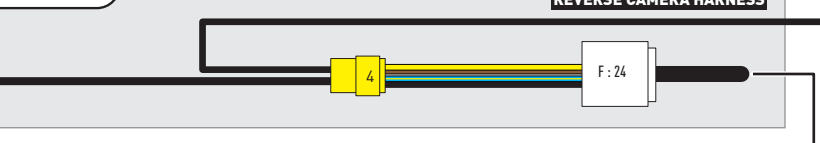

STEP 3

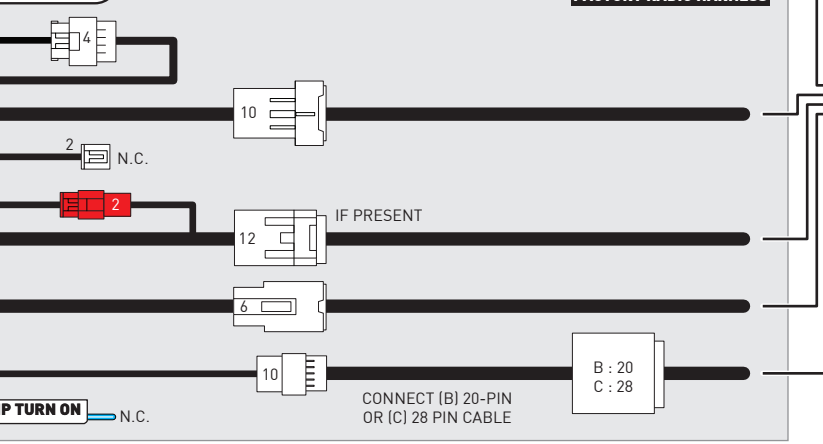

STEP 4



STEP 6

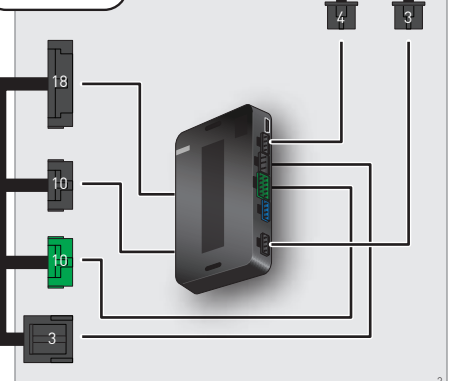

NOT REQUIRED

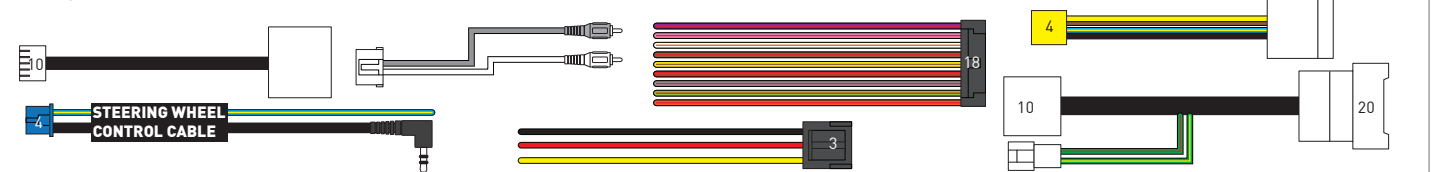

RADIO WIRE REFERENCE CHART

T01 T-harness Wire Description	Polarity	Wire Color on Maestro T-Harness	Wire Color on Alpine cable	Wire Color on Kenwood/ JVC cable	Wire Color on Pioneer cable	Wire Color on Sony cable
Illumination	(+)	Orange	N/A	Orange/White	Orange/White	Orange
Reverse Light*	(+)	Purple/White	Orange/White	Purple/White	Purple/White	Purple/White
E-Brake	(-)	Lt Green	Yellow/Blue	Lt Green	Lt Green	Lt Green
VSS (vehicle speed sensor)	(DATA)	Pink	Green/White	Pink	Pink	N/A

Head unit adapter wiring (optional accessory, sold separately)

ACC-HU-ALP1 Wire Description	Polarity	Wire Color on Adapter	Alpine Radio
VSS (vehicle speed sensor)	(DATA)	Green/White	Green/White









ACC-HU-KEN1 Wire Description	Polarity	Wire Color on Adapter	Kenwood Radio
CAM	(+)	Green/Red	Refer to camera/radio manual
CAM	(-)	Green/White	Refer to camera/radio manual
Steering Wheel Controls	(DATA)	Blue/Yellow	n/a

ACC-HU-KEN2 Wire Description	Polarity	Wire Color on Adapter	Kenwood Radio
E-Brake	(-)	LtGreen	LtGreen
Reverse Light*	(+)	Purple/White	Purple/White
Steering Wheel Controls	(DATA)	Blue/Yellow	n/a

* Reverse light wire: Only connect to radio or module damage will occur.

MODULE DIAGNOSTICS



LED 1 Module/Firmware status	LED 2 (RR2) Bluetooth activity	LED STATUS	DIAGNOSTIC
 or 		RED or GREEN flashing	LED flashes 1 or more times, either red or green, when a steering wheel button is pressed : normal operation.
		1 RED flash	Module has no firmware. Flash module using Weblink Desktop and log in. Do <u>NOT</u> use DEMO MODE.
		2 RED flashes	Problem detected. Consult troubleshooting table.
		1 GREEN flash	After radio boots up : Normal operation.
		3 GREEN flashes	Bluetooth is activated. Turns off after one minute: Normal operation.
		OFF	Normal operation (inactive).

VIDEO HELP		Installation, product information, vehicle specific videos.
VERIFY FLASH		Last flash information, steering control configuration, vehicle information.
WEBLINK		Software to program module.

TROUBLESHOOTING TABLE

PROBLEM	SOLUTION
Gauges do not work, radio shows OBD2 Error 1 or Error 2.	<p>Ensure OBDII connector is securely attached to the OBDII connector of the vehicle.</p> <p>If you hardwired connections at the OBDII, check connections at the OBDII connector. Make sure the RED/BROWN wire is on PIN 6 and the YELLOW/BROWN wire is connected to PIN 14 of the OBDII connector. Do not use T-Taps. Soldering or military splicing methods are recommended.</p> <p>If anything else is connected to the OBD2 or CAN wires of vehicle (programmer, throttle controller, insurance tracker, etc.) try unplugging it to see if gauges work. If gauges work without it installed, call tech support for options.</p> <p>Reset the RR.</p>
The light on the Maestro is blinking RED TWICE and the radio IS turning on.	<p>Ensure the 4-pin data cable is connected between the radio and the RR, and that it is plugged into the black port on the Maestro RR. The red and blue ports on the RR should be empty.</p> <p>Make sure the correct radio model and serial number were entered during the flash. Verify the radio's serial number entered during the flash matches what is listed on the radio screen. This can be found in the settings of the radio, listed as Device Id, Device Number, or Serial Number.</p>
The light on the Maestro is blinking RED TWICE but the radio is NOT turning on.	<p>If installing a modular radio and it is not turning on, ensure the screen is secured and any trim pieces on the radio have been installed fully. Not installing these fully will prevent radio from powering up and show a 2x red error as well.</p> <p>Test red and yellow wires for DC voltage at radio using a multimeter. Contact support if no voltage on red or yellow.</p>
The steering wheel controls are not working, the Maestro RR does not blink when they are pressed.	<p>Ensure the 20 or 28-pin connector is plugged to the vehicle and to the T01 T-harness, as shown in step 3 (this is where the RR gets the steering wheel signal from the vehicle).</p>
(Prius only) After the car is turned off, the radio stays on. The car stays in accessory mode and will not turn off.	<p>Locate the white 12-pin connector of the T01 harness, it is connected to the vehicle harness.</p> <p>Then, cut and isolate the red wire located at pin 11. The radio will shut off when the vehicle is turned off.</p>

MAESTRO RR RESET PROCEDURE:

Turn the key to the OFF position, then disconnect all connectors from the module.

Press and hold the module's programming button and connect all the connectors back to the module. Wait, the module's LED will flash RED rapidly (this may take up to 10 seconds).

Release the programming button. Wait, the LED will turn solid GREEN for 2 seconds to show the reset was successful.

TECHNICAL ASSISTANCE

Phone: 1-866-427-2999

Email: maestro.support@idatalink.com

IMPORTANT: To ensure proper operation, the aftermarket radio needs to have the latest firmware from the manufacturer. Please visit the radio manufacturer's website and look for any updates pertaining to your radio.

RETAINS STEERING WHEEL CONTROLS, FACTORY AMPLIFIER, AND MORE!



PRODUCTS REQUIRED

iDatalink Maestro RR or RR2 Radio Replacement Interface
iDatalink Maestro HRR-T01 Installation Harness

PROGRAMMED FIRMWARE

ADS-RR(SR)-TOY01-DS

ADDITIONAL RESOURCES

[Maestro RR2 Programmable Outputs Guide](#)

OPTIONAL ACCESSORIES

K40[™]
ELECTRONICS
ESCORT

Click here for:
[Radar Installation Guides](#)

HEAD UNIT ADAPTER:
ACC-HU-PI01, SON1, KEN1, KEN2, ALP1

WELCOME

Congratulations on the purchase of your iDatalink Maestro RR Radio replacement solution. You are now a few simple steps away from enjoying your new car radio with enhanced features.

Before starting your installation, please ensure that your iDatalink Maestro module is programmed with the correct firmware for your vehicle and that you carefully review the install guide.

Please note that Maestro RR will only retain functionalities that were originally available in the vehicle.

TABLE OF CONTENTS

Installation Instructions	3
Wiring Diagram	4
Radio Wire Reference Chart	5
Module Diagnostics	6
Troubleshooting Table	7

NEED HELP?

 1 866 427-2999

 maestro.support@idatalink.com

INSTALLATION INSTRUCTIONS P1/1

STEP 1

Remove the factory radio

If using head unit adapter (sold separately), connect HRR-T01 harness to adapter and skip to step 2.

- Unbox the aftermarket radio and locate its main harness.
- Cut and remove the black 20 pin connector from the HRR-T01 T-harness and connect the wires, shown in the wiring diagram, from aftermarket radio main harness to the HRR-T01 T-harness and match the wire functions.

Note: only connect purple/white wire to radio reverse input or module damage will occur.

STEP 2

- If the vehicle is equipped with an OEM backup camera, connect the HRR-T01 harness to appropriate HRR adapter cable (D, E or F) then connect to the backup camera harness.

STEP 3

- Identify if your vehicle has a 20 or 28 pin secondary connector.
- Assemble T01 T-harness as shown on wiring diagram.
- Connect the factory harness to the HRR-T01 harness.

STEP 4

- Connect HRR-T01 3-pin black connector to black connector of OBDII extension harness.
- Plug the OBDII connector into the OBDII of the vehicle.

STEP 5

- Plug the harnesses into the aftermarket radio.
- Connect the backup camera RCA cable into the aftermarket radio (if equipped).
- Plug the Data cable to the data port of the aftermarket radio.
- Insert the Audio cable into the iDatalink 3.5 mm audio jack of the aftermarket radio (if there is no iDatalink audio input, connect to AUX).

Note: On Pioneer radio, ensure that there is nothing plugged into the W/R port.

STEP 6

- Connect all the harnesses to the Maestro RR module then test your installation.

WIRING DIAGRAM *without an Amplifier*

STEP 1

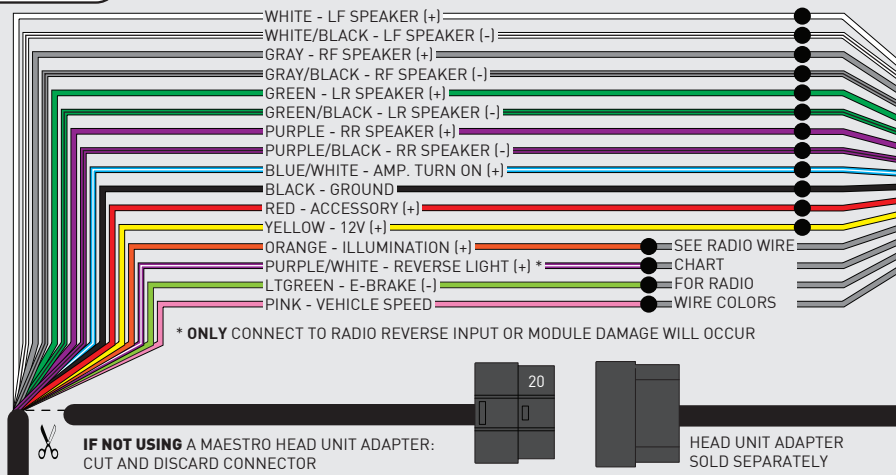

STEP 5

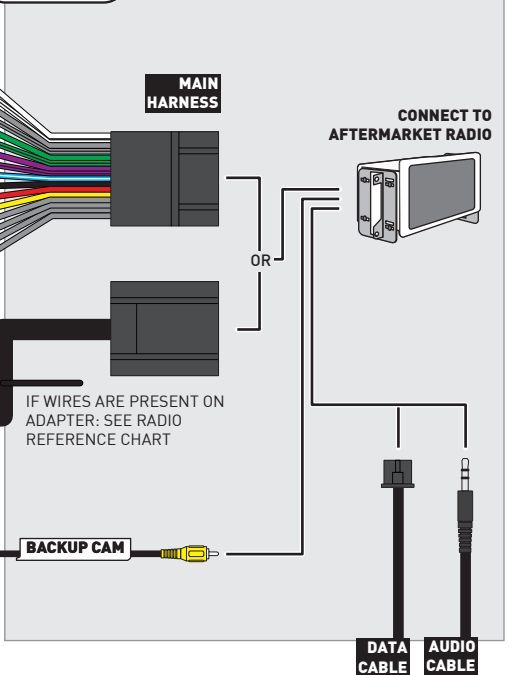

STEP 2

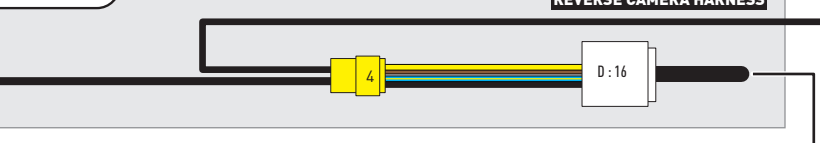

STEP 3

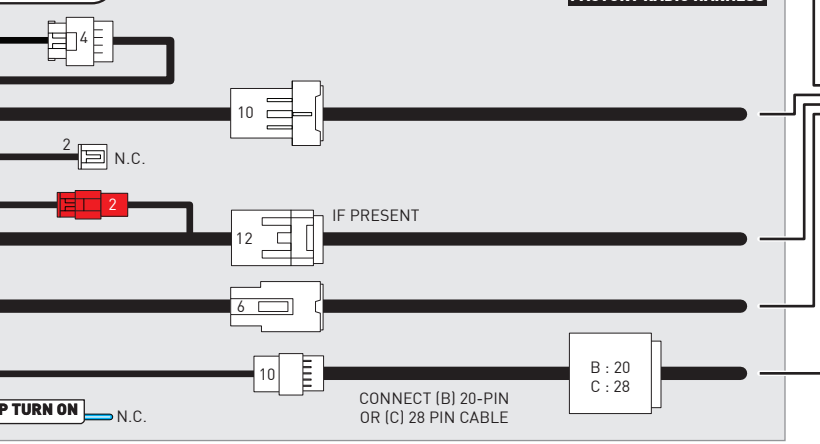

STEP 4



STEP 6

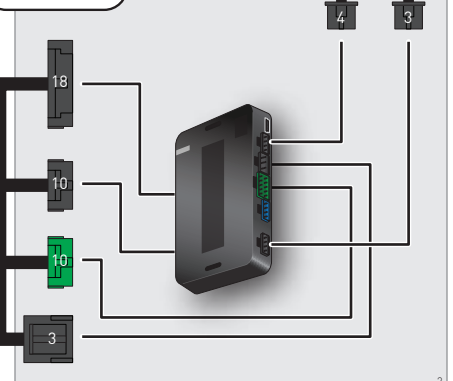

NOT REQUIRED

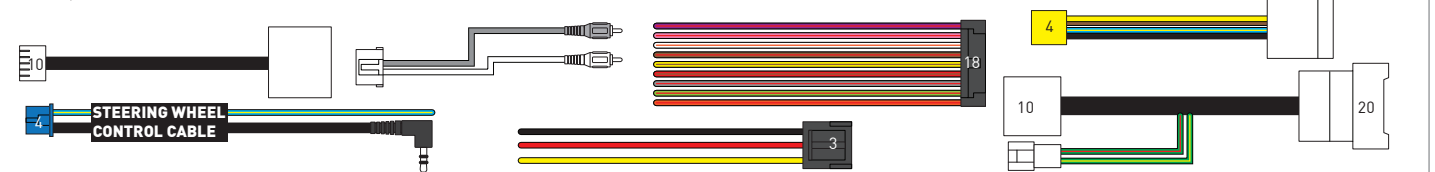

RADIO WIRE REFERENCE CHART

T01 T-harness Wire Description	Polarity	Wire Color on Maestro T-Harness	Wire Color on Alpine cable	Wire Color on Kenwood/JVC cable	Wire Color on Pioneer cable	Wire Color on Sony cable
Illumination	(+)	Orange	N/A	Orange/White	Orange/White	Orange
Reverse Light*	(+)	Purple/White	Orange/White	Purple/White	Purple/White	Purple/White
E-Brake	(-)	Lt Green	Yellow/Blue	Lt Green	Lt Green	Lt Green
VSS (vehicle speed sensor)	(DATA)	Pink	Green/White	Pink	Pink	N/A

Head unit adapter wiring (optional accessory, sold separately)

ACC-HU-ALP1 Wire Description	Polarity	Wire Color on Adapter	Alpine Radio
VSS (vehicle speed sensor)	(DATA)	Green/White	Green/White

ACC-HU-KEN1 Wire Description	Polarity	Wire Color on Adapter	Kenwood Radio
CAM	(+)	Green/Red	Refer to camera/radio manual
CAM	(-)	Green/White	Refer to camera/radio manual
Steering Wheel Controls	(DATA)	Blue/Yellow	n/a

ACC-HU-KEN2 Wire Description	Polarity	Wire Color on Adapter	Kenwood Radio
E-Brake	(-)	LtGreen	LtGreen
Reverse Light*	(+)	Purple/White	Purple/White
Steering Wheel Controls	(DATA)	Blue/Yellow	n/a

* Reverse light wire: Only connect to radio or module damage will occur.

MODULE DIAGNOSTICS



LED 1 Module/Firmware status	LED 2 (RR2) Bluetooth activity	LED STATUS	DIAGNOSTIC
or		RED or GREEN flashing	LED flashes 1 or more times, either red or green, when a steering wheel button is pressed : normal operation.
		1 RED flash	Module has no firmware. Flash module using Weblink Desktop and log in. Do <u>NOT</u> use DEMO MODE.
		2 RED flashes	Problem detected. Consult troubleshooting table.
		1 GREEN flash	After radio boots up : Normal operation.
		3 GREEN flashes	Bluetooth is activated. Turns off after one minute: Normal operation.
		OFF	Normal operation (inactive).

VIDEO HELP		Installation, product information, vehicle specific videos.
VERIFY FLASH		Last flash information, steering control configuration, vehicle information.
WEBLINK		Software to program module.

TROUBLESHOOTING TABLE

PROBLEM	SOLUTION
Gauges do not work, radio shows OBD2 Error 1 or Error 2.	<p>Ensure OBDII connector is securely attached to the OBDII connector of the vehicle.</p> <p>If you hardwired connections at the OBDII, check connections at the OBDII connector. Make sure the RED/BROWN wire is on PIN 6 and the YELLOW/BROWN wire is connected to PIN 14 of the OBDII connector. Do not use T-Taps. Soldering or military splicing methods are recommended.</p> <p>If anything else is connected to the OBD2 or CAN wires of vehicle (programmer, throttle controller, insurance tracker, etc.) try unplugging it to see if gauges work. If gauges work without it installed, call tech support for options.</p> <p>Reset the RR.</p>
The light on the Maestro is blinking RED TWICE and the radio IS turning on.	<p>Ensure the 4-pin data cable is connected between the radio and the RR, and that it is plugged into the black port on the Maestro RR. The red and blue ports on the RR should be empty.</p> <p>Make sure the correct radio model and serial number were entered during the flash. Verify the radio's serial number entered during the flash matches what is listed on the radio screen. This can be found in the settings of the radio, listed as Device Id, Device Number, or Serial Number.</p>
The light on the Maestro is blinking RED TWICE but the radio is NOT turning on.	<p>If installing a modular radio and it is not turning on, ensure the screen is secured and any trim pieces on the radio have been installed fully. Not installing these fully will prevent radio from powering up and show a 2x red error as well.</p> <p>Test red and yellow wires for DC voltage at radio using a multimeter. Contact support if no voltage on red or yellow.</p>
The steering wheel controls are not working, the Maestro RR does not blink when they are pressed.	<p>Ensure the 20 or 28-pin connector is plugged to the vehicle and to the T01 T-harness, as shown in step 3 (this is where the RR gets the steering wheel signal from the vehicle).</p>
(Prius only) After the car is turned off, the radio stays on. The car stays in accessory mode and will not turn off.	<p>Locate the white 12-pin connector of the T01 harness, it is connected to the vehicle harness.</p> <p>Then, cut and isolate the red wire located at pin 11. The radio will shut off when the vehicle is turned off.</p>

MAESTRO RR RESET PROCEDURE:

Turn the key to the OFF position, then disconnect all connectors from the module.

Press and hold the module's programming button and connect all the connectors back to the module. Wait, the module's LED will flash RED rapidly (this may take up to 10 seconds).

Release the programming button. Wait, the LED will turn solid GREEN for 2 seconds to show the reset was successful.

TECHNICAL ASSISTANCE

Phone: 1-866-427-2999

Email: maestro.support@idatalink.com

IMPORTANT: To ensure proper operation, the aftermarket radio needs to have the latest firmware from the manufacturer. Please visit the radio manufacturer's website and look for any updates pertaining to your radio.

RETAINS STEERING WHEEL CONTROLS, FACTORY AMPLIFIER, AND MORE!



PRODUCTS REQUIRED

iDatalink Maestro RR or RR2 Radio Replacement Interface
iDatalink Maestro HRR-T01 Installation Harness

PROGRAMMED FIRMWARE

ADS-RR(SR)-TOY01-DS

ADDITIONAL RESOURCES

[Maestro RR2 Programmable Outputs Guide](#)

OPTIONAL ACCESSORIES

K40[™]
ELECTRONICS
ESCORT

Click here for:
[Radar Installation Guides](#)

HEAD UNIT ADAPTER:
ACC-HU-PI01, SON1, KEN1, KEN2, ALP1

WELCOME

Congratulations on the purchase of your iDatalink Maestro RR Radio replacement solution. You are now a few simple steps away from enjoying your new car radio with enhanced features.

Before starting your installation, please ensure that your iDatalink Maestro module is programmed with the correct firmware for your vehicle and that you carefully review the install guide.

Please note that Maestro RR will only retain functionalities that were originally available in the vehicle.

NEED HELP?

 1 866 427-2999

 maestro.support@idatalink.com

TABLE OF CONTENTS

Installation Instructions	3
Wiring Diagram	4
Radio Wire Reference Chart	5
Module Diagnostics	6
Troubleshooting Table	7

INSTALLATION INSTRUCTIONS P1/1

STEP 1

Remove the factory radio

If using head unit adapter (sold separately), connect HRR-T01 harness to adapter and skip to step 2.

- Unbox the aftermarket radio and locate its main harness.
- Cut and remove the black 20 pin connector from the HRR-T01 T-harness and connect the wires, shown in the wiring diagram, from aftermarket radio main harness to the HRR-T01 T-harness and match the wire functions.

Note: only connect purple/white wire to radio reverse input or module damage will occur.

STEP 2

- Identify if your vehicle has a 20 or 28 pin secondary connector.
- Assemble T01 T-harness as shown on wiring diagram.
- Connect the factory harness to the HRR-T01 harness.

STEP 3

- Connect HRR-T01 3-pin black connector to black connector of OBDII extension harness.
- Plug the OBDII connector into the OBDII of the vehicle.

STEP 4

- Plug the harnesses into the aftermarket radio.
- Plug the Data cable to the data port of the aftermarket radio.
- Insert the Audio cable into the iDatalink 3.5 mm audio jack of the aftermarket radio (if there is no iDatalink audio input, connect to AUX).

Note: On Pioneer radio, ensure that there is nothing plugged into the W/R port.

STEP 5

- Connect all the harnesses to the Maestro RR module then test your installation.

WIRING DIAGRAM *without an Amplifier*

STEP 1

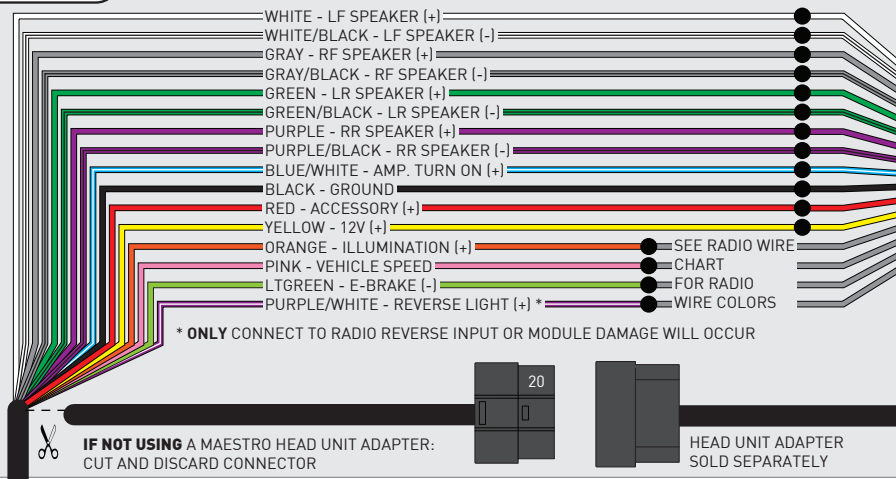

STEP 4

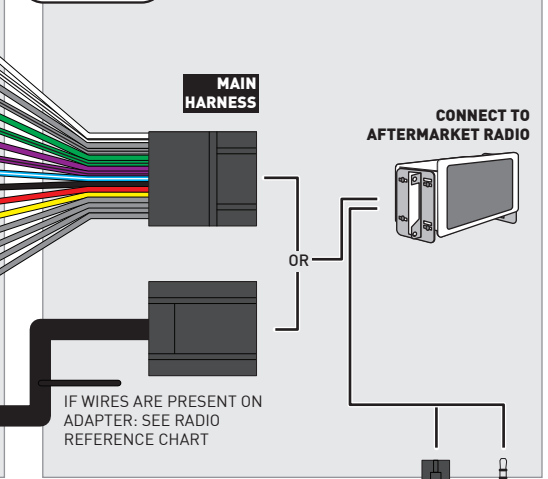

STEP 2

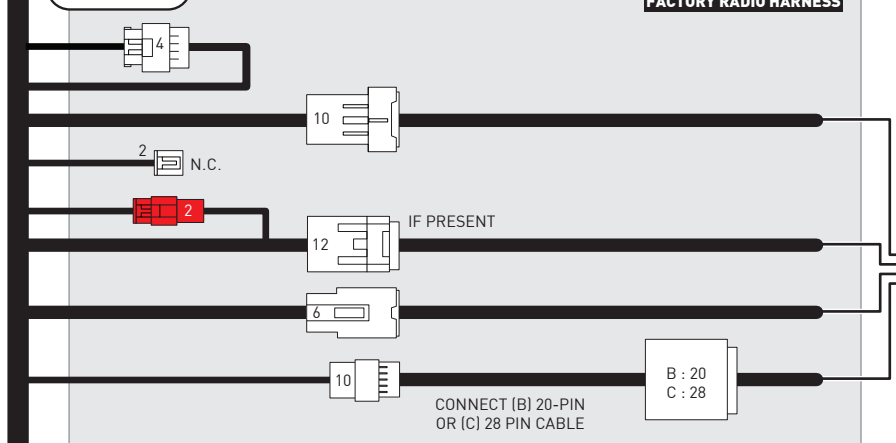

STEP 3

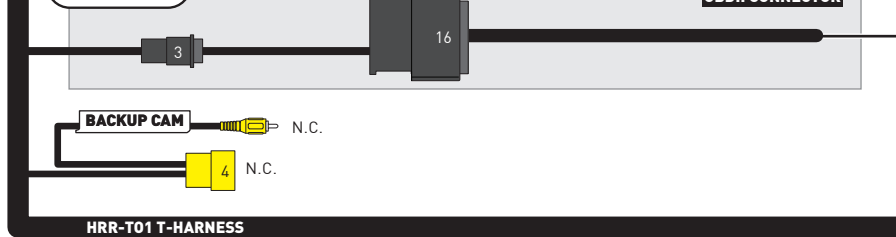

STEP 5

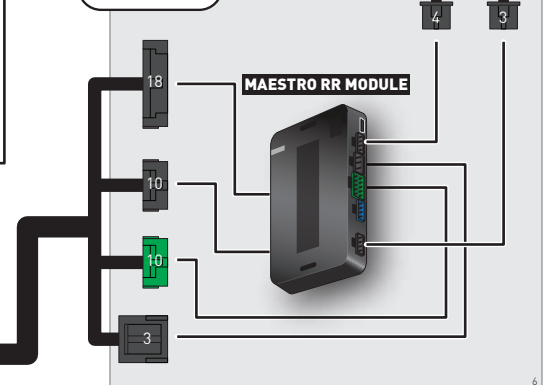

NOT REQUIRED

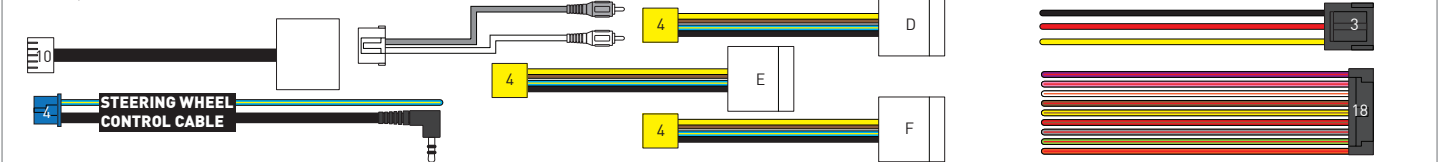

RADIO WIRE REFERENCE CHART

T01 T-harness Wire Description	Polarity	Wire Color on Maestro T-Harness	Wire Color on Alpine cable	Wire Color on Kenwood/JVC cable	Wire Color on Pioneer cable	Wire Color on Sony cable
Illumination	(+)	Orange	N/A	Orange/White	Orange/White	Orange
Reverse Light*	(+)	Purple/White	Orange/White	Purple/White	Purple/White	Purple/White
E-Brake	(-)	Lt Green	Yellow/Blue	Lt Green	Lt Green	Lt Green
VSS (vehicle speed sensor)	(DATA)	Pink	Green/White	Pink	Pink	N/A

Head unit adapter wiring (optional accessory, sold separately)

ACC-HU-ALP1 Wire Description	Polarity	Wire Color on Adapter	Alpine Radio
VSS (vehicle speed sensor)	(DATA)	Green/White	Green/White

ACC-HU-KEN1 Wire Description	Polarity	Wire Color on Adapter	Kenwood Radio
CAM	(+)	Green/Red	Refer to camera/radio manual
CAM	(-)	Green/White	Refer to camera/radio manual
Steering Wheel Controls	(DATA)	Blue/Yellow	n/a

ACC-HU-KEN2 Wire Description	Polarity	Wire Color on Adapter	Kenwood Radio
E-Brake	(-)	LtGreen	LtGreen
Reverse Light*	(+)	Purple/White	Purple/White
Steering Wheel Controls	(DATA)	Blue/Yellow	n/a

* Reverse light wire: Only connect to radio or module damage will occur.

MODULE DIAGNOSTICS



LED 1 Module/Firmware status	LED 2 (RR2) Bluetooth activity	LED STATUS	DIAGNOSTIC
or		RED or GREEN flashing	LED flashes 1 or more times, either red or green, when a steering wheel button is pressed : normal operation.
		1 RED flash	Module has no firmware. Flash module using Weblink Desktop and log in. Do <u>NOT</u> use DEMO MODE.
		2 RED flashes	Problem detected. Consult troubleshooting table.
		1 GREEN flash	After radio boots up : Normal operation.
		3 GREEN flashes	Bluetooth is activated. Turns off after one minute: Normal operation.
		OFF	Normal operation (inactive).

VIDEO HELP		Installation, product information, vehicle specific videos.
VERIFY FLASH		Last flash information, steering control configuration, vehicle information.
WEBLINK		Software to program module.

TROUBLESHOOTING TABLE

PROBLEM	SOLUTION
Gauges do not work, radio shows OBD2 Error 1 or Error 2.	<p>Ensure OBDII connector is securely attached to the OBDII connector of the vehicle.</p> <p>If you hardwired connections at the OBDII, check connections at the OBDII connector. Make sure the RED/BROWN wire is on PIN 6 and the YELLOW/BROWN wire is connected to PIN 14 of the OBDII connector. Do not use T-Taps. Soldering or military splicing methods are recommended.</p> <p>If anything else is connected to the OBD2 or CAN wires of vehicle (programmer, throttle controller, insurance tracker, etc.) try unplugging it to see if gauges work. If gauges work without it installed, call tech support for options.</p> <p>Reset the RR.</p>
The light on the Maestro is blinking RED TWICE and the radio IS turning on.	<p>Ensure the 4-pin data cable is connected between the radio and the RR, and that it is plugged into the black port on the Maestro RR. The red and blue ports on the RR should be empty.</p> <p>Make sure the correct radio model and serial number were entered during the flash. Verify the radio's serial number entered during the flash matches what is listed on the radio screen. This can be found in the settings of the radio, listed as Device Id, Device Number, or Serial Number.</p>
The light on the Maestro is blinking RED TWICE but the radio is NOT turning on.	<p>If installing a modular radio and it is not turning on, ensure the screen is secured and any trim pieces on the radio have been installed fully. Not installing these fully will prevent radio from powering up and show a 2x red error as well.</p> <p>Test red and yellow wires for DC voltage at radio using a multimeter. Contact support if no voltage on red or yellow.</p>
The steering wheel controls are not working, the Maestro RR does not blink when they are pressed.	<p>Ensure the 20 or 28-pin connector is plugged to the vehicle and to the T01 T-harness, as shown in step 3 (this is where the RR gets the steering wheel signal from the vehicle).</p>
(Prius only) After the car is turned off, the radio stays on. The car stays in accessory mode and will not turn off.	<p>Locate the white 12-pin connector of the T01 harness, it is connected to the vehicle harness.</p> <p>Then, cut and isolate the red wire located at pin 11. The radio will shut off when the vehicle is turned off.</p>

MAESTRO RR RESET PROCEDURE:

Turn the key to the OFF position, then disconnect all connectors from the module.

Press and hold the module's programming button and connect all the connectors back to the module. Wait, the module's LED will flash RED rapidly (this may take up to 10 seconds).

Release the programming button. Wait, the LED will turn solid GREEN for 2 seconds to show the reset was successful.

TECHNICAL ASSISTANCE

Phone: 1-866-427-2999

Email: maestro.support@idatalink.com

IMPORTANT: To ensure proper operation, the aftermarket radio needs to have the latest firmware from the manufacturer. Please visit the radio manufacturer's website and look for any updates pertaining to your radio.

RETAINS STEERING WHEEL CONTROLS, FACTORY AMPLIFIER, AND MORE!



PRODUCTS REQUIRED

iDataLink Maestro RR or RR2 Radio Replacement Interface
iDataLink Maestro HRR-T01 Installation Harness

PROGRAMMED FIRMWARE

ADS-RR(SR)-TOY01-DS

ADDITIONAL RESOURCES

[Maestro RR2 Programmable Outputs Guide](#)

OPTIONAL ACCESSORIES

K40[™]
ELECTRONICS
ESCORT

Click here for:
[Radar Installation Guides](#)

HEAD UNIT ADAPTER:
ACC-HU-PI01, SON1, KEN1, KEN2, ALP1

WELCOME

Congratulations on the purchase of your iDatalink Maestro RR Radio replacement solution. You are now a few simple steps away from enjoying your new car radio with enhanced features.

Before starting your installation, please ensure that your iDatalink Maestro module is programmed with the correct firmware for your vehicle and that you carefully review the install guide.

Please note that Maestro RR will only retain functionalities that were originally available in the vehicle.

TABLE OF CONTENTS

Installation Instructions	3
Wiring Diagram	4
Radio Wire Reference Chart	5
Module Diagnostics	6
Troubleshooting Table	7

NEED HELP?

 1 866 427-2999

 maestro.support@idatalink.com

INSTALLATION INSTRUCTIONS P1/1

STEP 1

Remove the factory radio

If using head unit adapter (sold separately), connect HRR-T01 harness to adapter and skip to step 2.

- Unbox the aftermarket radio and locate its main harness.
- Cut and remove the black 20 pin connector from the HRR-T01 T-harness and connect the wires, shown in the wiring diagram, from aftermarket radio main harness to the HRR-T01 T-harness and match the wire functions.

Note: only connect purple/white wire to radio reverse input or module damage will occur.

STEP 2

- If the vehicle is equipped with an OEM backup camera, connect the HRR-T01 harness to appropriate HRR adapter cable (D, E or F) then connect to the backup camera harness.

STEP 3

- Identify if your vehicle has a 20 or 28 pin secondary connector.
- Assemble T01 T-harness as shown on wiring diagram.
- Connect the factory harness to the HRR-T01 harness.

STEP 4

- Connect HRR-T01 3-pin black connector to black connector of OBDII extension harness.
- Plug the OBDII connector into the OBDII of the vehicle.

STEP 5

- Plug the harnesses into the aftermarket radio.
- Connect the backup camera RCA cable into the aftermarket radio (if equipped).
- Connect the left front and right front low level outputs RCA cables into the aftermarket radio.
- Plug the Data cable to the data port of the aftermarket radio.
- Insert the Audio cable into the iDatalink 3.5 mm audio jack of the aftermarket radio (if there is no iDatalink audio input, connect to AUX).

Note: On Pioneer radio, ensure that there is nothing plugged into the W/R port.

STEP 6

- Connect all the harnesses to the Maestro RR module then test your installation.

WIRING DIAGRAM *with an Amplifier*

STEP 1

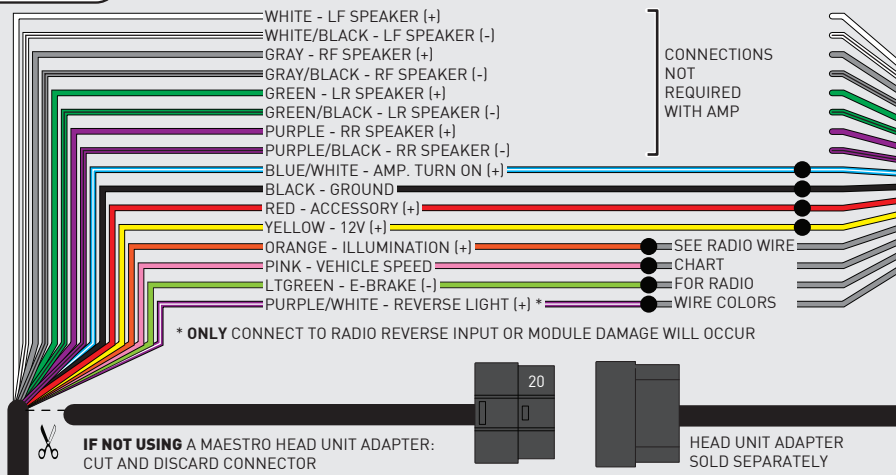

STEP 5

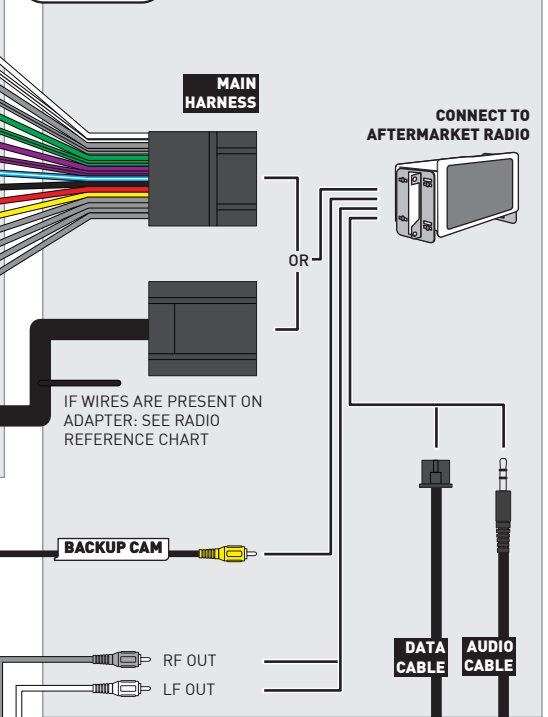

STEP 2

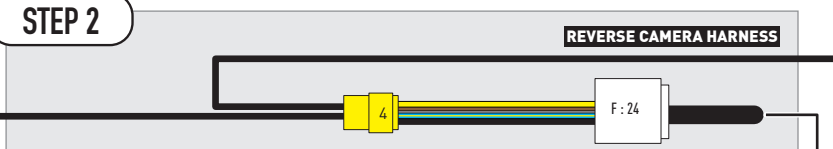

STEP 3

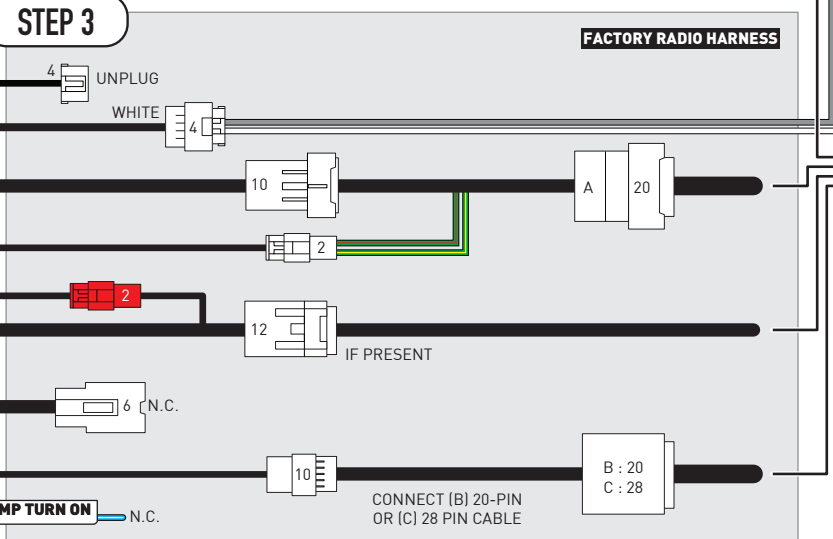

STEP 4

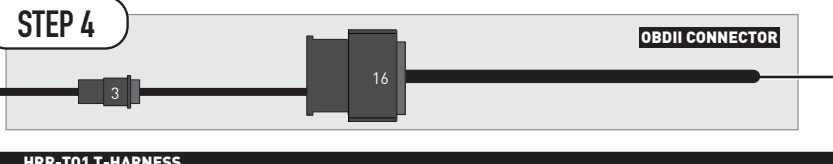

STEP 6

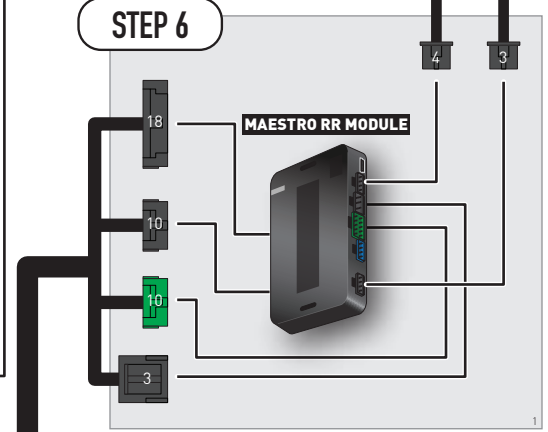

NOT REQUIRED

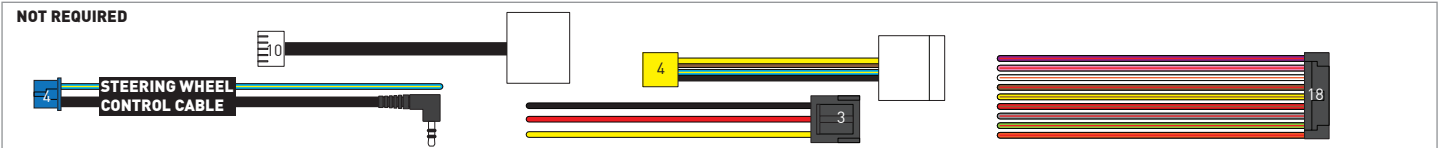

RADIO WIRE REFERENCE CHART

T01 T-harness Wire Description	Polarity	Wire Color on Maestro T-Harness	Wire Color on Alpine cable	Wire Color on Kenwood/ JVC cable	Wire Color on Pioneer cable	Wire Color on Sony cable
Illumination	(+)	Orange	N/A	Orange/White	Orange/White	Orange
Reverse Light*	(+)	Purple/White	Orange/White	Purple/White	Purple/White	Purple/White
E-Brake	(-)	Lt Green	Yellow/Blue	Lt Green	Lt Green	Lt Green
VSS (vehicle speed sensor)	(DATA)	Pink	Green/White	Pink	Pink	N/A

Head unit adapter wiring (optional accessory, sold separately)

ACC-HU-ALP1 Wire Description	Polarity	Wire Color on Adapter	Alpine Radio
VSS (vehicle speed sensor)	(DATA)	Green/White	Green/White

ACC-HU-KEN1 Wire Description	Polarity	Wire Color on Adapter	Kenwood Radio
CAM	(+)	Green/Red	Refer to camera/radio manual
CAM	(-)	Green/White	Refer to camera/radio manual
Steering Wheel Controls	(DATA)	Blue/Yellow	n/a

ACC-HU-KEN2 Wire Description	Polarity	Wire Color on Adapter	Kenwood Radio
E-Brake	(-)	LtGreen	LtGreen
Reverse Light*	(+)	Purple/White	Purple/White
Steering Wheel Controls	(DATA)	Blue/Yellow	n/a

* Reverse light wire: Only connect to radio or module damage will occur.

MODULE DIAGNOSTICS



LED 1 Module/Firmware status	LED 2 (RR2) Bluetooth activity	LED STATUS	DIAGNOSTIC
or		RED or GREEN flashing	LED flashes 1 or more times, either red or green, when a steering wheel button is pressed : normal operation.
		1 RED flash	Module has no firmware. Flash module using Weblink Desktop and log in. Do <u>NOT</u> use DEMO MODE.
		2 RED flashes	Problem detected. Consult troubleshooting table.
		1 GREEN flash	After radio boots up : Normal operation.
		3 GREEN flashes	Bluetooth is activated. Turns off after one minute: Normal operation.
		OFF	Normal operation (inactive).

VIDEO HELP		Installation, product information, vehicle specific videos.
VERIFY FLASH		Last flash information, steering control configuration, vehicle information.
WEBLINK		Software to program module.

TROUBLESHOOTING TABLE

PROBLEM	SOLUTION
Gauges do not work, radio shows OBD2 Error 1 or Error 2.	<p>Ensure OBDII connector is securely attached to the OBDII connector of the vehicle.</p> <p>If you hardwired connections at the OBDII, check connections at the OBDII connector. Make sure the RED/BROWN wire is on PIN 6 and the YELLOW/BROWN wire is connected to PIN 14 of the OBDII connector. Do not use T-Taps. Soldering or military splicing methods are recommended.</p> <p>If anything else is connected to the OBD2 or CAN wires of vehicle (programmer, throttle controller, insurance tracker, etc.) try unplugging it to see if gauges work. If gauges work without it installed, call tech support for options.</p> <p>Reset the RR.</p>
The light on the Maestro is blinking RED TWICE and the radio IS turning on.	<p>Ensure the 4-pin data cable is connected between the radio and the RR, and that it is plugged into the black port on the Maestro RR. The red and blue ports on the RR should be empty.</p> <p>Make sure the correct radio model and serial number were entered during the flash. Verify the radio's serial number entered during the flash matches what is listed on the radio screen. This can be found in the settings of the radio, listed as Device Id, Device Number, or Serial Number.</p>
The light on the Maestro is blinking RED TWICE but the radio is NOT turning on.	<p>If installing a modular radio and it is not turning on, ensure the screen is secured and any trim pieces on the radio have been installed fully. Not installing these fully will prevent radio from powering up and show a 2x red error as well.</p> <p>Test red and yellow wires for DC voltage at radio using a multimeter. Contact support if no voltage on red or yellow.</p>
The steering wheel controls are not working, the Maestro RR does not blink when they are pressed.	<p>Ensure the 20 or 28-pin connector is plugged to the vehicle and to the T01 T-harness, as shown in step 3 (this is where the RR gets the steering wheel signal from the vehicle).</p>
(Prius only) After the car is turned off, the radio stays on. The car stays in accessory mode and will not turn off.	<p>Locate the white 12-pin connector of the T01 harness, it is connected to the vehicle harness.</p> <p>Then, cut and isolate the red wire located at pin 11. The radio will shut off when the vehicle is turned off.</p>

MAESTRO RR RESET PROCEDURE:

Turn the key to the OFF position, then disconnect all connectors from the module.

Press and hold the module's programming button and connect all the connectors back to the module. Wait, the module's LED will flash RED rapidly (this may take up to 10 seconds).

Release the programming button. Wait, the LED will turn solid GREEN for 2 seconds to show the reset was successful.

TECHNICAL ASSISTANCE

Phone: 1-866-427-2999

Email: maestro.support@idatalink.com

IMPORTANT: To ensure proper operation, the aftermarket radio needs to have the latest firmware from the manufacturer. Please visit the radio manufacturer's website and look for any updates pertaining to your radio.

RETAINS STEERING WHEEL CONTROLS, FACTORY AMPLIFIER, AND MORE!



PRODUCTS REQUIRED

iDataLink Maestro RR or RR2 Radio Replacement Interface
iDataLink Maestro HRR-T01 Installation Harness

PROGRAMMED FIRMWARE

ADS-RR(SR)-TOY01-DS

ADDITIONAL RESOURCES

[Maestro RR2 Programmable Outputs Guide](#)

OPTIONAL ACCESSORIES

K40[™]
ELECTRONICS
ESCORT

Click here for:
[Radar Installation Guides](#)

HEAD UNIT ADAPTER:
ACC-HU-PI01, SON1, KEN1, KEN2, ALP1

WELCOME

Congratulations on the purchase of your iDatalink Maestro RR Radio replacement solution. You are now a few simple steps away from enjoying your new car radio with enhanced features.

Before starting your installation, please ensure that your iDatalink Maestro module is programmed with the correct firmware for your vehicle and that you carefully review the install guide.

Please note that Maestro RR will only retain functionalities that were originally available in the vehicle.

TABLE OF CONTENTS

Installation Instructions	3
Wiring Diagram	4
Radio Wire Reference Chart	5
Module Diagnostics	6
Troubleshooting Table	7

NEED HELP?

 1 866 427-2999

 maestro.support@idatalink.com

INSTALLATION INSTRUCTIONS P1/1

STEP 1

Remove the factory radio

If using head unit adapter (sold separately), connect HRR-T01 harness to adapter and skip to step 2.

- Unbox the aftermarket radio and locate its main harness.
- Cut and remove the black 20 pin connector from the HRR-T01 T-harness and connect the wires, shown in the wiring diagram, from aftermarket radio main harness to the HRR-T01 T-harness and match the wire functions.

Note: only connect purple/white wire to radio reverse input or module damage will occur.

STEP 2

- If the vehicle is equipped with an OEM backup camera, connect the HRR-T01 harness to appropriate HRR adapter cable (D, E or F) then connect to the backup camera harness.

STEP 3

- Identify if your vehicle has a 20 or 28 pin secondary connector.
- Assemble T01 T-harness as shown on wiring diagram.
- Connect the factory harness to the HRR-T01 harness.

STEP 4

- Connect HRR-T01 3-pin black connector to black connector of OBDII extension harness.
- Plug the OBDII connector into the OBDII of the vehicle.

STEP 5

- Plug the harnesses into the aftermarket radio.
- Connect the backup camera RCA cable into the aftermarket radio (if equipped).
- Plug the Data cable to the data port of the aftermarket radio.
- Insert the Audio cable into the iDatalink 3.5 mm audio jack of the aftermarket radio (if there is no iDatalink audio input, connect to AUX).

Note: On Pioneer radio, ensure that there is nothing plugged into the W/R port.

STEP 6

- Connect all the harnesses to the Maestro RR module then test your installation.

WIRING DIAGRAM *without an Amplifier*

STEP 1

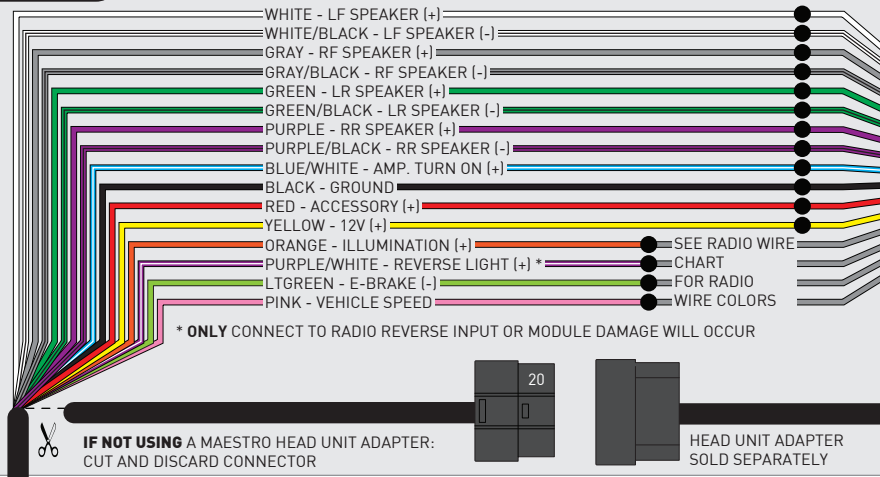

STEP 5

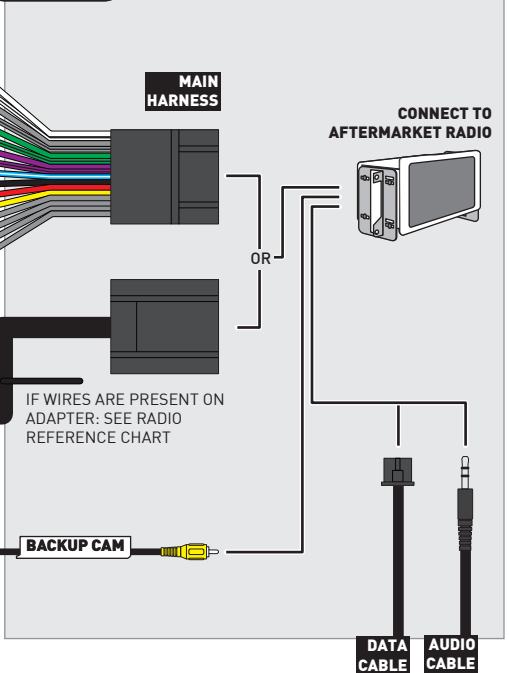

STEP 2

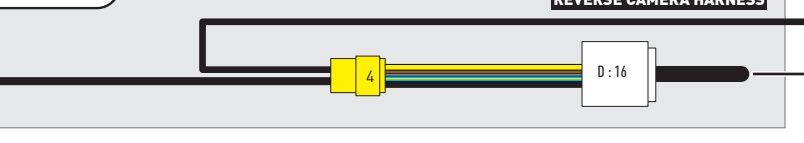

STEP 3

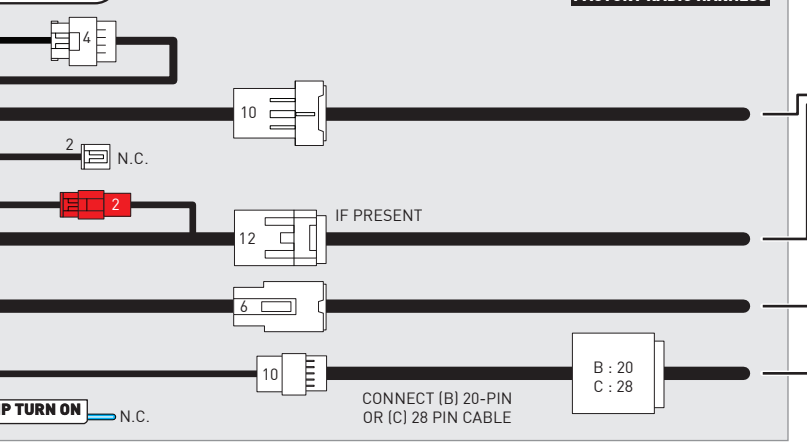

STEP 4

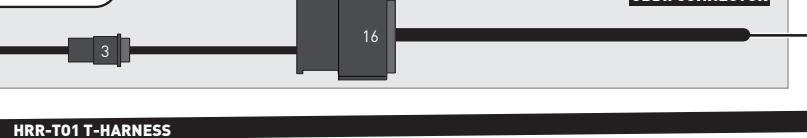

STEP 6

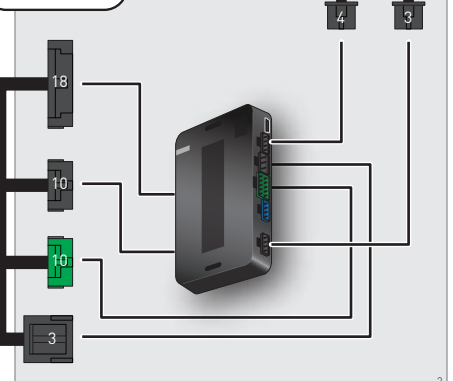

NOT REQUIRED

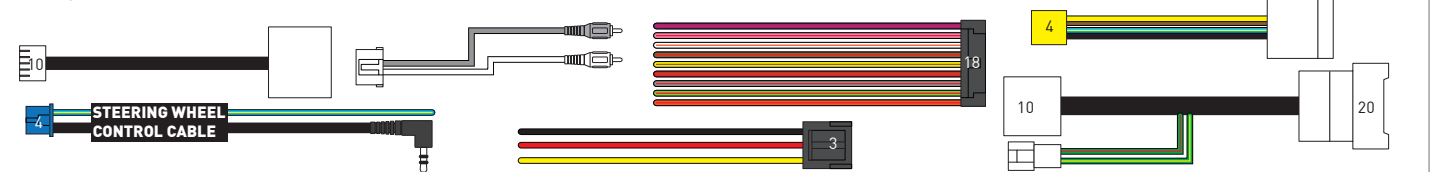

RADIO WIRE REFERENCE CHART

T01 T-harness Wire Description	Polarity	Wire Color on Maestro T-Harness	Wire Color on Alpine cable	Wire Color on Kenwood/ JVC cable	Wire Color on Pioneer cable	Wire Color on Sony cable
Illumination	(+)	Orange	N/A	Orange/White	Orange/White	Orange
Reverse Light*	(+)	Purple/White	Orange/White	Purple/White	Purple/White	Purple/White
E-Brake	(-)	Lt Green	Yellow/Blue	Lt Green	Lt Green	Lt Green
VSS (vehicle speed sensor)	(DATA)	Pink	Green/White	Pink	Pink	N/A

Head unit adapter wiring (optional accessory, sold separately)

ACC-HU-ALP1 Wire Description	Polarity	Wire Color on Adapter	Alpine Radio
VSS (vehicle speed sensor)	(DATA)	Green/White	Green/White

ACC-HU-KEN1 Wire Description	Polarity	Wire Color on Adapter	Kenwood Radio
CAM	(+)	Green/Red	Refer to camera/radio manual
CAM	(-)	Green/White	Refer to camera/radio manual
Steering Wheel Controls	(DATA)	Blue/Yellow	n/a

ACC-HU-KEN2 Wire Description	Polarity	Wire Color on Adapter	Kenwood Radio
E-Brake	(-)	LtGreen	LtGreen
Reverse Light*	(+)	Purple/White	Purple/White
Steering Wheel Controls	(DATA)	Blue/Yellow	n/a

* Reverse light wire: Only connect to radio or module damage will occur.

MODULE DIAGNOSTICS



LED 1 Module/Firmware status	LED 2 (RR2) Bluetooth activity	LED STATUS	DIAGNOSTIC
or		RED or GREEN flashing	LED flashes 1 or more times, either red or green, when a steering wheel button is pressed : normal operation.
		1 RED flash	Module has no firmware. Flash module using Weblink Desktop and log in. Do <u>NOT</u> use DEMO MODE.
		2 RED flashes	Problem detected. Consult troubleshooting table.
		1 GREEN flash	After radio boots up : Normal operation.
		3 GREEN flashes	Bluetooth is activated. Turns off after one minute: Normal operation.
		OFF	Normal operation (inactive).

VIDEO HELP		Installation, product information, vehicle specific videos.
VERIFY FLASH		Last flash information, steering control configuration, vehicle information.
WEBLINK		Software to program module.

TROUBLESHOOTING TABLE

PROBLEM	SOLUTION
Gauges do not work, radio shows OBD2 Error 1 or Error 2.	<p>Ensure OBDII connector is securely attached to the OBDII connector of the vehicle.</p> <p>If you hardwired connections at the OBDII, check connections at the OBDII connector. Make sure the RED/BROWN wire is on PIN 6 and the YELLOW/BROWN wire is connected to PIN 14 of the OBDII connector. Do not use T-Taps. Soldering or military splicing methods are recommended.</p> <p>If anything else is connected to the OBD2 or CAN wires of vehicle (programmer, throttle controller, insurance tracker, etc.) try unplugging it to see if gauges work. If gauges work without it installed, call tech support for options.</p> <p>Reset the RR.</p>
The light on the Maestro is blinking RED TWICE and the radio IS turning on.	<p>Ensure the 4-pin data cable is connected between the radio and the RR, and that it is plugged into the black port on the Maestro RR. The red and blue ports on the RR should be empty.</p> <p>Make sure the correct radio model and serial number were entered during the flash. Verify the radio's serial number entered during the flash matches what is listed on the radio screen. This can be found in the settings of the radio, listed as Device Id, Device Number, or Serial Number.</p>
The light on the Maestro is blinking RED TWICE but the radio is NOT turning on.	<p>If installing a modular radio and it is not turning on, ensure the screen is secured and any trim pieces on the radio have been installed fully. Not installing these fully will prevent radio from powering up and show a 2x red error as well.</p> <p>Test red and yellow wires for DC voltage at radio using a multimeter. Contact support if no voltage on red or yellow.</p>
The steering wheel controls are not working, the Maestro RR does not blink when they are pressed.	<p>Ensure the 20 or 28-pin connector is plugged to the vehicle and to the T01 T-harness, as shown in step 3 (this is where the RR gets the steering wheel signal from the vehicle).</p>
(Prius only) After the car is turned off, the radio stays on. The car stays in accessory mode and will not turn off.	<p>Locate the white 12-pin connector of the T01 harness, it is connected to the vehicle harness.</p> <p>Then, cut and isolate the red wire located at pin 11. The radio will shut off when the vehicle is turned off.</p>

MAESTRO RR RESET PROCEDURE:

Turn the key to the OFF position, then disconnect all connectors from the module.

Press and hold the module's programming button and connect all the connectors back to the module. Wait, the module's LED will flash RED rapidly (this may take up to 10 seconds).

Release the programming button. Wait, the LED will turn solid GREEN for 2 seconds to show the reset was successful.

TECHNICAL ASSISTANCE

Phone: 1-866-427-2999

Email: maestro.support@idatalink.com

IMPORTANT: To ensure proper operation, the aftermarket radio needs to have the latest firmware from the manufacturer. Please visit the radio manufacturer's website and look for any updates pertaining to your radio.

RETAINS STEERING WHEEL CONTROLS, FACTORY AMPLIFIER, AND MORE!



PRODUCTS REQUIRED

iDatalink Maestro RR or RR2 Radio Replacement Interface
iDatalink Maestro HRR-T01 Installation Harness

PROGRAMMED FIRMWARE

ADS-RR(SR)-TOY01-DS

ADDITIONAL RESOURCES

[Maestro RR2 Programmable Outputs Guide](#)

OPTIONAL ACCESSORIES

K40[™]
ELECTRONICS
ESCORT

Click here for:
[Radar Installation Guides](#)

HEAD UNIT ADAPTER:
ACC-HU-PI01, SON1, KEN1, KEN2, ALP1

WELCOME

Congratulations on the purchase of your iDatalink Maestro RR Radio replacement solution. You are now a few simple steps away from enjoying your new car radio with enhanced features.

Before starting your installation, please ensure that your iDatalink Maestro module is programmed with the correct firmware for your vehicle and that you carefully review the install guide.

Please note that Maestro RR will only retain functionalities that were originally available in the vehicle.

TABLE OF CONTENTS

Installation Instructions	3
Wiring Diagram	4
Radio Wire Reference Chart	5
Module Diagnostics	6
Troubleshooting Table	7

NEED HELP?

 1 866 427-2999

 maestro.support@idatalink.com

INSTALLATION INSTRUCTIONS P1/1

STEP 1

Remove the factory radio

If using head unit adapter (sold separately), connect HRR-T01 harness to adapter and skip to step 2.

- Unbox the aftermarket radio and locate its main harness.
- Cut and remove the black 20 pin connector from the HRR-T01 T-harness and connect the wires, shown in the wiring diagram, from aftermarket radio main harness to the HRR-T01 T-harness and match the wire functions.

Note: only connect purple/white wire to radio reverse input or module damage will occur.

STEP 2

- If the vehicle is equipped with an OEM backup camera, connect the HRR-T01 harness to appropriate HRR adapter cable (D, E or F) then connect to the backup camera harness.

STEP 3

- Identify if your vehicle has a 20 or 28 pin secondary connector.
- Assemble T01 T-harness as shown on wiring diagram.
- Connect the factory harness to the HRR-T01 harness.

STEP 4

- Connect HRR-T01 3-pin black connector to black connector of OBDII extension harness.
- Plug the OBDII connector into the OBDII of the vehicle.

STEP 5

- Plug the harnesses into the aftermarket radio.
- Connect the backup camera RCA cable into the aftermarket radio (if equipped).
- Plug the Data cable to the data port of the aftermarket radio.
- Insert the Audio cable into the iDatalink 3.5 mm audio jack of the aftermarket radio (if there is no iDatalink audio input, connect to AUX).

Note: On Pioneer radio, ensure that there is nothing plugged into the W/R port.

STEP 6

- Connect all the harnesses to the Maestro RR module then test your installation.

WIRING DIAGRAM *without an Amplifier*

STEP 1

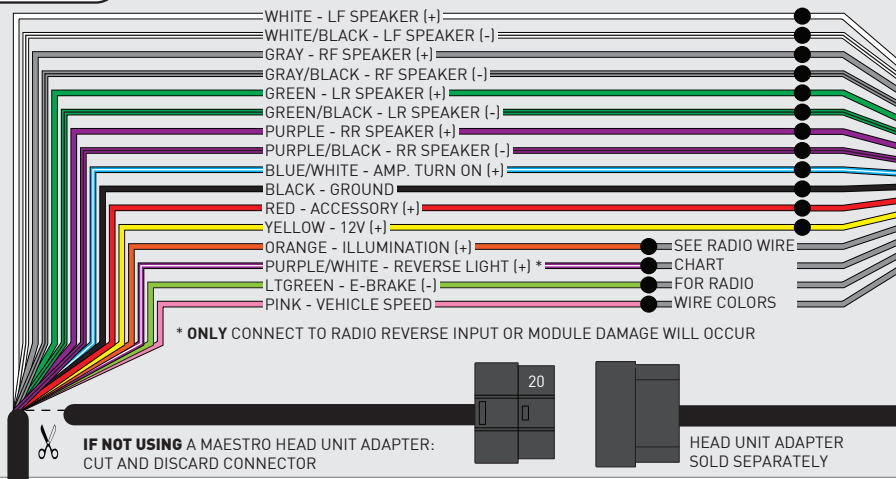

STEP 5

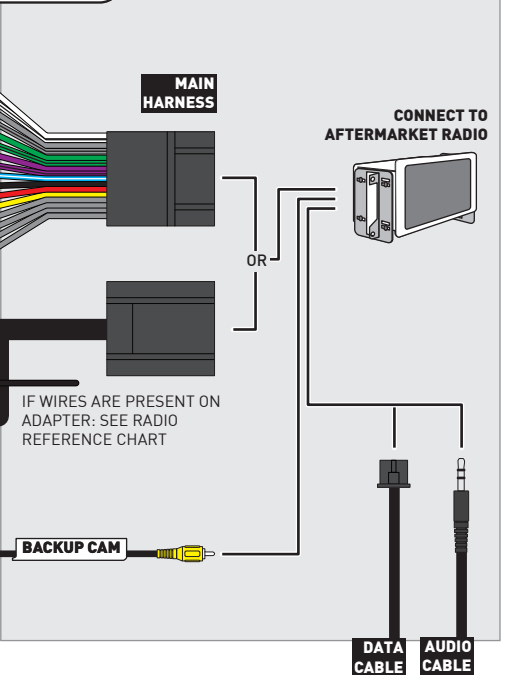

STEP 2

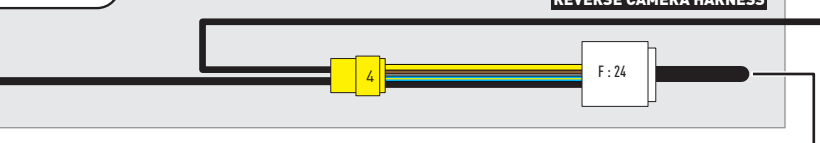

STEP 3

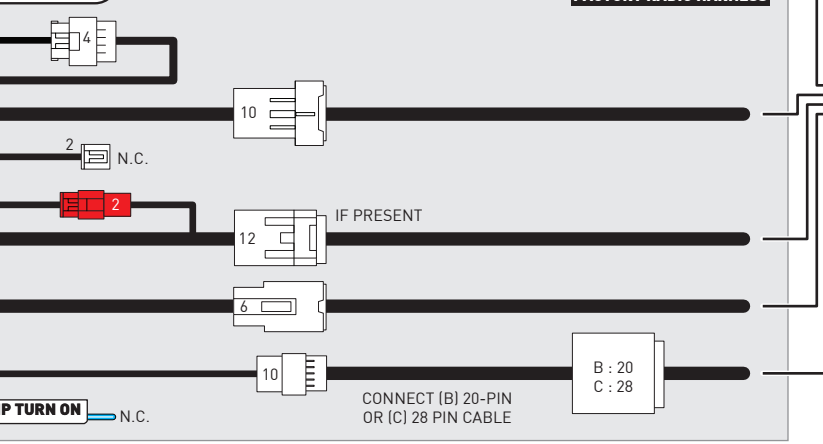

STEP 4



STEP 6

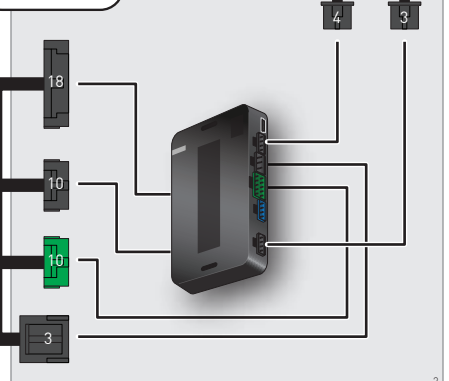

NOT REQUIRED

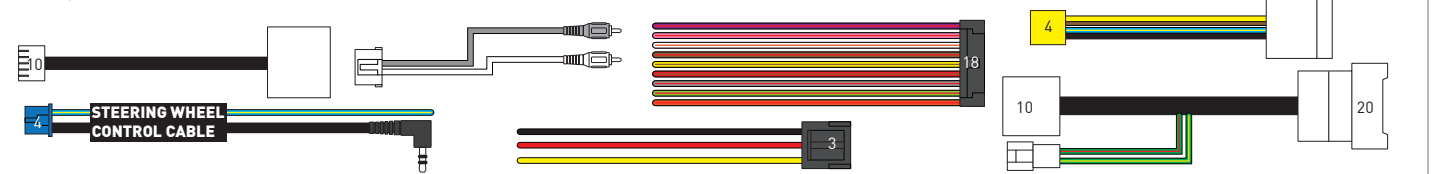

RADIO WIRE REFERENCE CHART

T01 T-harness Wire Description	Polarity	Wire Color on Maestro T-Harness	Wire Color on Alpine cable	Wire Color on Kenwood/JVC cable	Wire Color on Pioneer cable	Wire Color on Sony cable
Illumination	(+)	Orange	N/A	Orange/White	Orange/White	Orange
Reverse Light*	(+)	Purple/White	Orange/White	Purple/White	Purple/White	Purple/White
E-Brake	(-)	Lt Green	Yellow/Blue	Lt Green	Lt Green	Lt Green
VSS (vehicle speed sensor)	(DATA)	Pink	Green/White	Pink	Pink	N/A

Head unit adapter wiring (optional accessory, sold separately)

ACC-HU-ALP1 Wire Description	Polarity	Wire Color on Adapter	Alpine Radio
VSS (vehicle speed sensor)	(DATA)	Green/White	Green/White









ACC-HU-KEN1 Wire Description	Polarity	Wire Color on Adapter	Kenwood Radio
CAM	(+)	Green/Red	Refer to camera/radio manual
CAM	(-)	Green/White	Refer to camera/radio manual
Steering Wheel Controls	(DATA)	Blue/Yellow	n/a

ACC-HU-KEN2 Wire Description	Polarity	Wire Color on Adapter	Kenwood Radio
E-Brake	(-)	LtGreen	LtGreen
Reverse Light*	(+)	Purple/White	Purple/White
Steering Wheel Controls	(DATA)	Blue/Yellow	n/a

* Reverse light wire: Only connect to radio or module damage will occur.

MODULE DIAGNOSTICS



LED 1 Module/Firmware status	LED 2 (RR2) Bluetooth activity	LED STATUS	DIAGNOSTIC
 or 		RED or GREEN flashing	LED flashes 1 or more times, either red or green, when a steering wheel button is pressed : normal operation.
		1 RED flash	Module has no firmware. Flash module using Weblink Desktop and log in. Do <u>NOT</u> use DEMO MODE.
		2 RED flashes	Problem detected. Consult troubleshooting table.
		1 GREEN flash	After radio boots up : Normal operation.
		3 GREEN flashes	Bluetooth is activated. Turns off after one minute: Normal operation.
		OFF	Normal operation (inactive).

VIDEO HELP		Installation, product information, vehicle specific videos.
VERIFY FLASH		Last flash information, steering control configuration, vehicle information.
WEBLINK		Software to program module.

TROUBLESHOOTING TABLE

PROBLEM	SOLUTION
Gauges do not work, radio shows OBD2 Error 1 or Error 2.	<p>Ensure OBDII connector is securely attached to the OBDII connector of the vehicle.</p> <p>If you hardwired connections at the OBDII, check connections at the OBDII connector. Make sure the RED/BROWN wire is on PIN 6 and the YELLOW/BROWN wire is connected to PIN 14 of the OBDII connector. Do not use T-Taps. Soldering or military splicing methods are recommended.</p> <p>If anything else is connected to the OBD2 or CAN wires of vehicle (programmer, throttle controller, insurance tracker, etc.) try unplugging it to see if gauges work. If gauges work without it installed, call tech support for options.</p> <p>Reset the RR.</p>
The light on the Maestro is blinking RED TWICE and the radio IS turning on.	<p>Ensure the 4-pin data cable is connected between the radio and the RR, and that it is plugged into the black port on the Maestro RR. The red and blue ports on the RR should be empty.</p> <p>Make sure the correct radio model and serial number were entered during the flash. Verify the radio's serial number entered during the flash matches what is listed on the radio screen. This can be found in the settings of the radio, listed as Device Id, Device Number, or Serial Number.</p>
The light on the Maestro is blinking RED TWICE but the radio is NOT turning on.	<p>If installing a modular radio and it is not turning on, ensure the screen is secured and any trim pieces on the radio have been installed fully. Not installing these fully will prevent radio from powering up and show a 2x red error as well.</p> <p>Test red and yellow wires for DC voltage at radio using a multimeter. Contact support if no voltage on red or yellow.</p>
The steering wheel controls are not working, the Maestro RR does not blink when they are pressed.	<p>Ensure the 20 or 28-pin connector is plugged to the vehicle and to the T01 T-harness, as shown in step 3 (this is where the RR gets the steering wheel signal from the vehicle).</p>
(Prius only) After the car is turned off, the radio stays on. The car stays in accessory mode and will not turn off.	<p>Locate the white 12-pin connector of the T01 harness, it is connected to the vehicle harness.</p> <p>Then, cut and isolate the red wire located at pin 11. The radio will shut off when the vehicle is turned off.</p>

MAESTRO RR RESET PROCEDURE:

Turn the key to the OFF position, then disconnect all connectors from the module.

Press and hold the module's programming button and connect all the connectors back to the module. Wait, the module's LED will flash RED rapidly (this may take up to 10 seconds).

Release the programming button. Wait, the LED will turn solid GREEN for 2 seconds to show the reset was successful.

TECHNICAL ASSISTANCE

Phone: 1-866-427-2999

Email: maestro.support@idatalink.com

IMPORTANT: To ensure proper operation, the aftermarket radio needs to have the latest firmware from the manufacturer. Please visit the radio manufacturer's website and look for any updates pertaining to your radio.

RETAINS STEERING WHEEL CONTROLS, FACTORY AMPLIFIER, AND MORE!



PRODUCTS REQUIRED

iDatalink Maestro RR or RR2 Radio Replacement Interface
iDatalink Maestro HRR-T01 Installation Harness

PROGRAMMED FIRMWARE

ADS-RR(SR)-TOY01-DS

ADDITIONAL RESOURCES

[Maestro RR2 Programmable Outputs Guide](#)

OPTIONAL ACCESSORIES

K40[™]
ELECTRONICS
ESCORT

Click here for:
[Radar Installation Guides](#)

HEAD UNIT ADAPTER:
ACC-HU-PI01, SON1, KEN1, KEN2, ALP1

WELCOME

Congratulations on the purchase of your iDatalink Maestro RR Radio replacement solution. You are now a few simple steps away from enjoying your new car radio with enhanced features.

Before starting your installation, please ensure that your iDatalink Maestro module is programmed with the correct firmware for your vehicle and that you carefully review the install guide.

Please note that Maestro RR will only retain functionalities that were originally available in the vehicle.

TABLE OF CONTENTS

Installation Instructions	3
Wiring Diagram	4
Radio Wire Reference Chart	5
Module Diagnostics	6
Troubleshooting Table	7

NEED HELP?

 1 866 427-2999

 maestro.support@idatalink.com

INSTALLATION INSTRUCTIONS P1/1

STEP 1

Remove the factory radio

If using head unit adapter (sold separately), connect HRR-T01 harness to adapter and skip to step 2.

- Unbox the aftermarket radio and locate its main harness.
- Cut and remove the black 20 pin connector from the HRR-T01 T-harness and connect the wires, shown in the wiring diagram, from aftermarket radio main harness to the HRR-T01 T-harness and match the wire functions.

Note: only connect purple/white wire to radio reverse input or module damage will occur.

STEP 2

- Identify if your vehicle has a 20 or 28 pin secondary connector.
- Assemble T01 T-harness as shown on wiring diagram.
- Connect the factory harness to the HRR-T01 harness.

STEP 3

- Connect HRR-T01 3-pin black connector to black connector of OBDII extension harness.
- Plug the OBDII connector into the OBDII of the vehicle.

STEP 4

- Plug the harnesses into the aftermarket radio.
- Connect the left front and right front low level outputs RCA cables into the aftermarket radio.
- Plug the Data cable to the data port of the aftermarket radio.
- Insert the Audio cable into the iDatalink 3.5 mm audio jack of the aftermarket radio (if there is no iDatalink audio input, connect to AUX).

Note: On Pioneer radio, ensure that there is nothing plugged into the W/R port.

STEP 5

- Connect all the harnesses to the Maestro RR module then test your installation.

WIRING DIAGRAM *with an Amplifier*

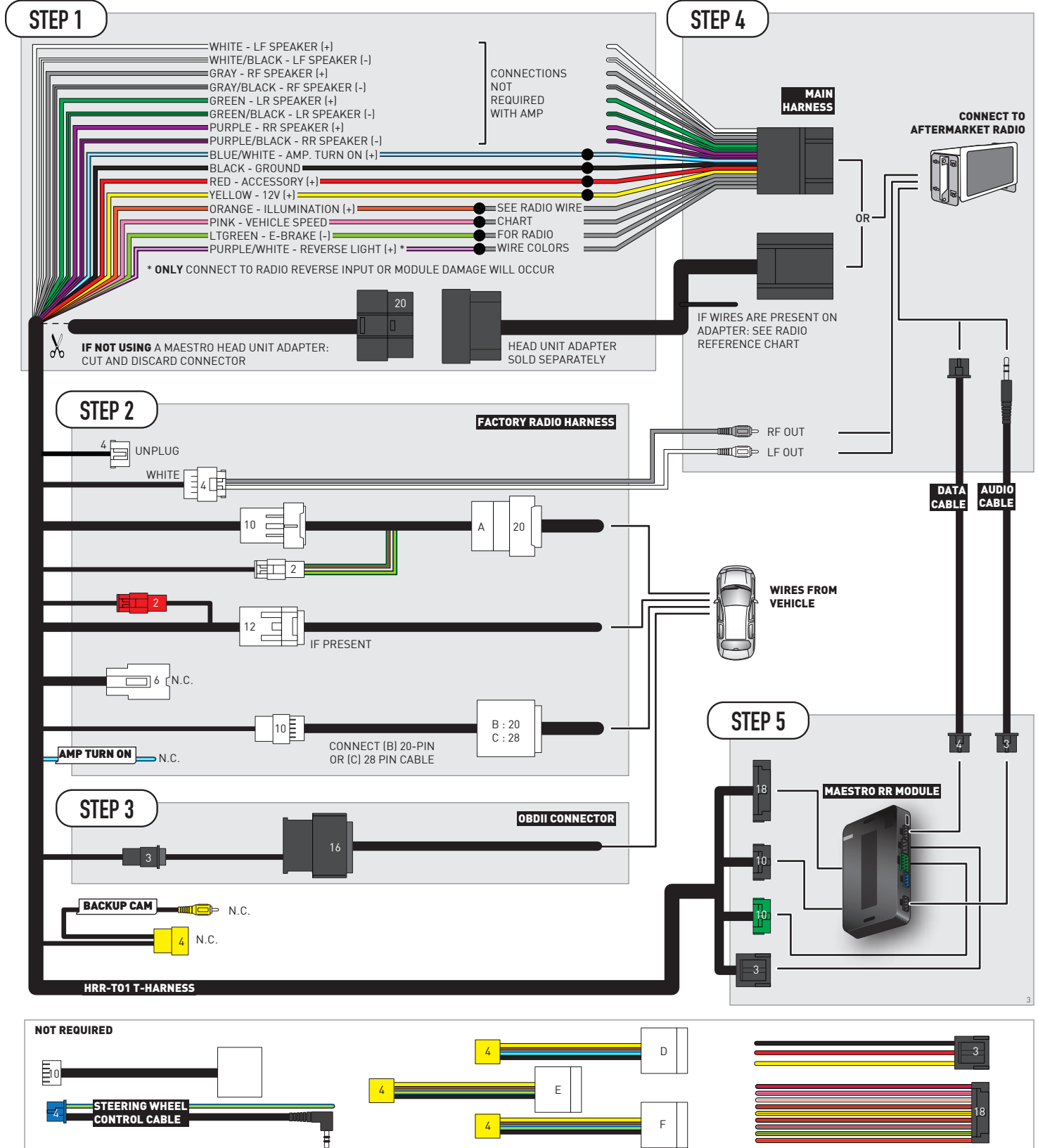

RADIO WIRE REFERENCE CHART

T01 T-harness Wire Description	Polarity	Wire Color on Maestro T-Harness	Wire Color on Alpine cable	Wire Color on Kenwood/JVC cable	Wire Color on Pioneer cable	Wire Color on Sony cable
Illumination	(+)	Orange	N/A	Orange/White	Orange/White	Orange
Reverse Light*	(+)	Purple/White	Orange/White	Purple/White	Purple/White	Purple/White
E-Brake	(-)	Lt Green	Yellow/Blue	Lt Green	Lt Green	Lt Green
VSS (vehicle speed sensor)	(DATA)	Pink	Green/White	Pink	Pink	N/A

Head unit adapter wiring (optional accessory, sold separately)

ACC-HU-ALP1 Wire Description	Polarity	Wire Color on Adapter	Alpine Radio
VSS (vehicle speed sensor)	(DATA)	Green/White	Green/White

ACC-HU-KEN1 Wire Description	Polarity	Wire Color on Adapter	Kenwood Radio
CAM	(+)	Green/Red	Refer to camera/radio manual
CAM	(-)	Green/White	Refer to camera/radio manual
Steering Wheel Controls	(DATA)	Blue/Yellow	n/a

ACC-HU-KEN2 Wire Description	Polarity	Wire Color on Adapter	Kenwood Radio
E-Brake	(-)	LtGreen	LtGreen
Reverse Light*	(+)	Purple/White	Purple/White
Steering Wheel Controls	(DATA)	Blue/Yellow	n/a

* Reverse light wire: Only connect to radio or module damage will occur.

MODULE DIAGNOSTICS



LED 1 Module/Firmware status	LED 2 (RR2) Bluetooth activity	LED STATUS	DIAGNOSTIC
or		RED or GREEN flashing	LED flashes 1 or more times, either red or green, when a steering wheel button is pressed : normal operation.
		1 RED flash	Module has no firmware. Flash module using Weblink Desktop and log in. Do <u>NOT</u> use DEMO MODE.
		2 RED flashes	Problem detected. Consult troubleshooting table.
		1 GREEN flash	After radio boots up : Normal operation.
		3 GREEN flashes	Bluetooth is activated. Turns off after one minute: Normal operation.
		OFF	Normal operation (inactive).

VIDEO HELP		Installation, product information, vehicle specific videos.
VERIFY FLASH		Last flash information, steering control configuration, vehicle information.
WEBLINK		Software to program module.

TROUBLESHOOTING TABLE

PROBLEM	SOLUTION
Gauges do not work, radio shows OBD2 Error 1 or Error 2.	<p>Ensure OBDII connector is securely attached to the OBDII connector of the vehicle.</p> <p>If you hardwired connections at the OBDII, check connections at the OBDII connector. Make sure the RED/BROWN wire is on PIN 6 and the YELLOW/BROWN wire is connected to PIN 14 of the OBDII connector. Do not use T-Taps. Soldering or military splicing methods are recommended.</p> <p>If anything else is connected to the OBD2 or CAN wires of vehicle (programmer, throttle controller, insurance tracker, etc.) try unplugging it to see if gauges work. If gauges work without it installed, call tech support for options.</p> <p>Reset the RR.</p>
The light on the Maestro is blinking RED TWICE and the radio IS turning on.	<p>Ensure the 4-pin data cable is connected between the radio and the RR, and that it is plugged into the black port on the Maestro RR. The red and blue ports on the RR should be empty.</p> <p>Make sure the correct radio model and serial number were entered during the flash. Verify the radio's serial number entered during the flash matches what is listed on the radio screen. This can be found in the settings of the radio, listed as Device Id, Device Number, or Serial Number.</p>
The light on the Maestro is blinking RED TWICE but the radio is NOT turning on.	<p>If installing a modular radio and it is not turning on, ensure the screen is secured and any trim pieces on the radio have been installed fully. Not installing these fully will prevent radio from powering up and show a 2x red error as well.</p> <p>Test red and yellow wires for DC voltage at radio using a multimeter. Contact support if no voltage on red or yellow.</p>
The steering wheel controls are not working, the Maestro RR does not blink when they are pressed.	<p>Ensure the 20 or 28-pin connector is plugged to the vehicle and to the T01 T-harness, as shown in step 3 (this is where the RR gets the steering wheel signal from the vehicle).</p>
(Prius only) After the car is turned off, the radio stays on. The car stays in accessory mode and will not turn off.	<p>Locate the white 12-pin connector of the T01 harness, it is connected to the vehicle harness.</p> <p>Then, cut and isolate the red wire located at pin 11. The radio will shut off when the vehicle is turned off.</p>

MAESTRO RR RESET PROCEDURE:

Turn the key to the OFF position, then disconnect all connectors from the module.

Press and hold the module's programming button and connect all the connectors back to the module. Wait, the module's LED will flash RED rapidly (this may take up to 10 seconds).

Release the programming button. Wait, the LED will turn solid GREEN for 2 seconds to show the reset was successful.

TECHNICAL ASSISTANCE

Phone: 1-866-427-2999

Email: maestro.support@idatalink.com

IMPORTANT: To ensure proper operation, the aftermarket radio needs to have the latest firmware from the manufacturer. Please visit the radio manufacturer's website and look for any updates pertaining to your radio.

2014-2015

TOYOTA COROLLA

WITHOUT FACTORY SCREEN

RETAINS STEERING WHEEL CONTROLS, FACTORY AMPLIFIER, AND MORE!



PRODUCTS REQUIRED

iDataLink Maestro RR or RR2 Radio Replacement Interface
iDataLink Maestro HRR-T01 Installation Harness

PROGRAMMED FIRMWARE

ADS-RR(SR)-TOY01-DS

ADDITIONAL RESOURCES

[Maestro RR2 Programmable Outputs Guide](#)

OPTIONAL ACCESSORIES



Click here for:
[Radar Installation Guides](#)

HEAD UNIT ADAPTER:
ACC-HU-PI01, SON1, KEN1, KEN2, ALP1

WELCOME

Congratulations on the purchase of your iDatalink Maestro RR Radio replacement solution. You are now a few simple steps away from enjoying your new car radio with enhanced features.

Before starting your installation, please ensure that your iDatalink Maestro module is programmed with the correct firmware for your vehicle and that you carefully review the install guide.

Please note that Maestro RR will only retain functionalities that were originally available in the vehicle.

NEED HELP?

 1 866 427-2999

 maestro.support@idatalink.com

TABLE OF CONTENTS

Installation Instructions	3
Wiring Diagram	4
Radio Wire Reference Chart	5
Module Diagnostics	6
Troubleshooting Table	7

INSTALLATION INSTRUCTIONS P1/1

STEP 1

Remove the factory radio

If using head unit adapter (sold separately), connect HRR-T01 harness to adapter and skip to step 2.

- Unbox the aftermarket radio and locate its main harness.
- Cut and remove the black 20 pin connector from the HRR-T01 T-harness and connect the wires, shown in the wiring diagram, from aftermarket radio main harness to the HRR-T01 T-harness and match the wire functions.

Note: only connect purple/white wire to radio reverse input or module damage will occur.

STEP 2

- Identify if your vehicle has a 20 or 28 pin secondary connector.
- Assemble T01 T-harness as shown on wiring diagram.
- Connect the factory harness to the HRR-T01 harness.

STEP 3

- Connect HRR-T01 3-pin black connector to black connector of OBDII extension harness.
- Plug the OBDII connector into the OBDII of the vehicle.

STEP 4

- Plug the harnesses into the aftermarket radio.
- Plug the Data cable to the data port of the aftermarket radio.
- Insert the Audio cable into the iDatalink 3.5 mm audio jack of the aftermarket radio (if there is no iDatalink audio input, connect to AUX).

Note: On Pioneer radio, ensure that there is nothing plugged into the W/R port.

STEP 5

- Connect all the harnesses to the Maestro RR module then test your installation.

WIRING DIAGRAM *without an Amplifier*

STEP 1

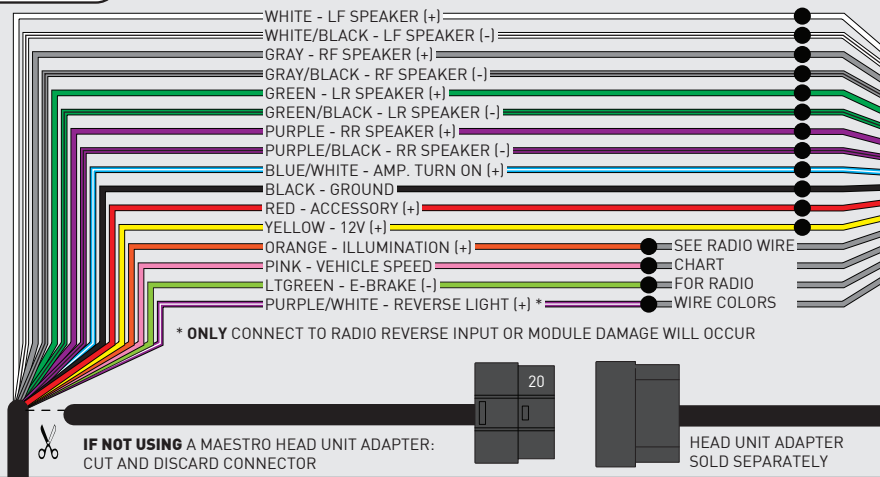

STEP 4

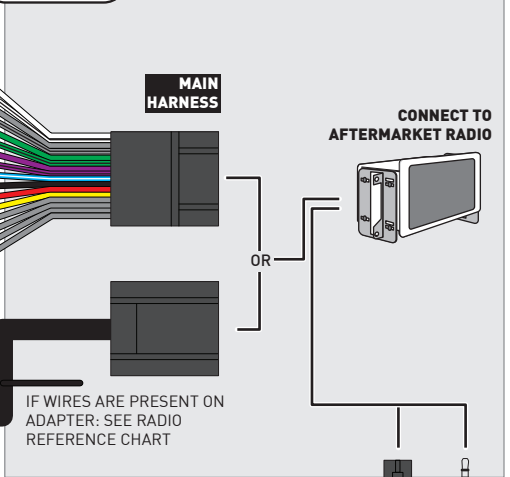

STEP 2

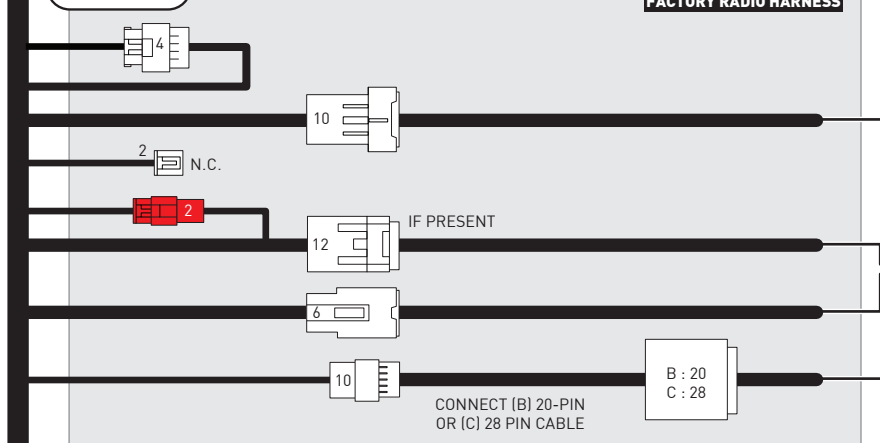

STEP 3

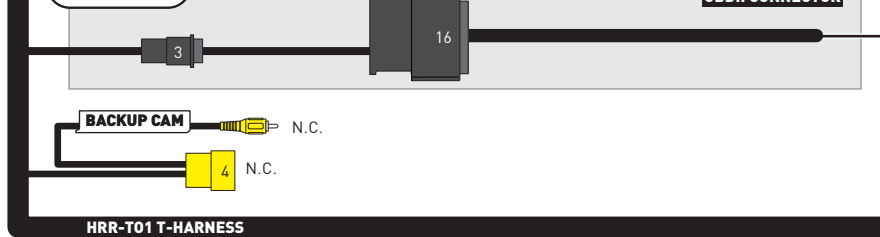

STEP 5

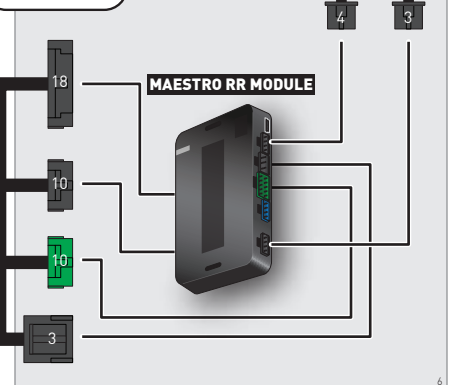

NOT REQUIRED

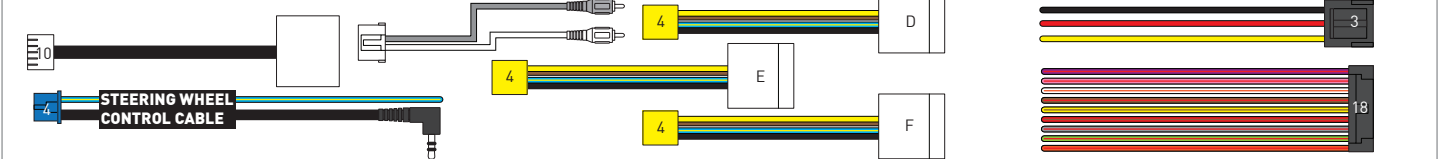

RADIO WIRE REFERENCE CHART

T01 T-harness Wire Description	Polarity	Wire Color on Maestro T-Harness	Wire Color on Alpine cable	Wire Color on Kenwood/ JVC cable	Wire Color on Pioneer cable	Wire Color on Sony cable
Illumination	(+)	Orange	N/A	Orange/White	Orange/White	Orange
Reverse Light*	(+)	Purple/White	Orange/White	Purple/White	Purple/White	Purple/White
E-Brake	(-)	Lt Green	Yellow/Blue	Lt Green	Lt Green	Lt Green
VSS (vehicle speed sensor)	(DATA)	Pink	Green/White	Pink	Pink	N/A

Head unit adapter wiring (optional accessory, sold separately)

ACC-HU-ALP1 Wire Description	Polarity	Wire Color on Adapter	Alpine Radio
VSS (vehicle speed sensor)	(DATA)	Green/White	Green/White

ACC-HU-KEN1 Wire Description	Polarity	Wire Color on Adapter	Kenwood Radio
CAM	(+)	Green/Red	Refer to camera/radio manual
CAM	(-)	Green/White	Refer to camera/radio manual
Steering Wheel Controls	(DATA)	Blue/Yellow	n/a

ACC-HU-KEN2 Wire Description	Polarity	Wire Color on Adapter	Kenwood Radio
E-Brake	(-)	LtGreen	LtGreen
Reverse Light*	(+)	Purple/White	Purple/White
Steering Wheel Controls	(DATA)	Blue/Yellow	n/a

* Reverse light wire: Only connect to radio or module damage will occur.

MODULE DIAGNOSTICS



LED 1 Module/Firmware status	LED 2 (RR2) Bluetooth activity	LED STATUS	DIAGNOSTIC
or		RED or GREEN flashing	LED flashes 1 or more times, either red or green, when a steering wheel button is pressed : normal operation.
		1 RED flash	Module has no firmware. Flash module using Weblink Desktop and log in. Do <u>NOT</u> use DEMO MODE.
		2 RED flashes	Problem detected. Consult troubleshooting table.
		1 GREEN flash	After radio boots up : Normal operation.
		3 GREEN flashes	Bluetooth is activated. Turns off after one minute: Normal operation.
		OFF	Normal operation (inactive).

VIDEO HELP		Installation, product information, vehicle specific videos.
VERIFY FLASH		Last flash information, steering control configuration, vehicle information.
WEBLINK		Software to program module.

TROUBLESHOOTING TABLE

PROBLEM	SOLUTION
Gauges do not work, radio shows OBD2 Error 1 or Error 2.	<p>Ensure OBDII connector is securely attached to the OBDII connector of the vehicle.</p> <p>If you hardwired connections at the OBDII, check connections at the OBDII connector. Make sure the RED/BROWN wire is on PIN 6 and the YELLOW/BROWN wire is connected to PIN 14 of the OBDII connector. Do not use T-Taps. Soldering or military splicing methods are recommended.</p> <p>If anything else is connected to the OBD2 or CAN wires of vehicle (programmer, throttle controller, insurance tracker, etc.) try unplugging it to see if gauges work. If gauges work without it installed, call tech support for options.</p> <p>Reset the RR.</p>
The light on the Maestro is blinking RED TWICE and the radio IS turning on.	<p>Ensure the 4-pin data cable is connected between the radio and the RR, and that it is plugged into the black port on the Maestro RR. The red and blue ports on the RR should be empty.</p> <p>Make sure the correct radio model and serial number were entered during the flash. Verify the radio's serial number entered during the flash matches what is listed on the radio screen. This can be found in the settings of the radio, listed as Device Id, Device Number, or Serial Number.</p>
The light on the Maestro is blinking RED TWICE but the radio is NOT turning on.	<p>If installing a modular radio and it is not turning on, ensure the screen is secured and any trim pieces on the radio have been installed fully. Not installing these fully will prevent radio from powering up and show a 2x red error as well.</p> <p>Test red and yellow wires for DC voltage at radio using a multimeter. Contact support if no voltage on red or yellow.</p>
The steering wheel controls are not working, the Maestro RR does not blink when they are pressed.	<p>Ensure the 20 or 28-pin connector is plugged to the vehicle and to the T01 T-harness, as shown in step 3 (this is where the RR gets the steering wheel signal from the vehicle).</p>
(Prius only) After the car is turned off, the radio stays on. The car stays in accessory mode and will not turn off.	<p>Locate the white 12-pin connector of the T01 harness, it is connected to the vehicle harness.</p> <p>Then, cut and isolate the red wire located at pin 11. The radio will shut off when the vehicle is turned off.</p>

MAESTRO RR RESET PROCEDURE:

Turn the key to the OFF position, then disconnect all connectors from the module.

Press and hold the module's programming button and connect all the connectors back to the module. Wait, the module's LED will flash RED rapidly (this may take up to 10 seconds).

Release the programming button. Wait, the LED will turn solid GREEN for 2 seconds to show the reset was successful.

TECHNICAL ASSISTANCE

Phone: 1-866-427-2999

Email: maestro.support@idatalink.com

IMPORTANT: To ensure proper operation, the aftermarket radio needs to have the latest firmware from the manufacturer. Please visit the radio manufacturer's website and look for any updates pertaining to your radio.

RETAINS STEERING WHEEL CONTROLS, FACTORY AMPLIFIER, AND MORE!



PRODUCTS REQUIRED

iDatalink Maestro RR or RR2 Radio Replacement Interface
iDatalink Maestro HRR-T01 Installation Harness

PROGRAMMED FIRMWARE

ADS-RR(SR)-TOY01-DS

ADDITIONAL RESOURCES

[Maestro RR2 Programmable Outputs Guide](#)

OPTIONAL ACCESSORIES

K40[™]
ELECTRONICS
ESCORT

Click here for:
[Radar Installation Guides](#)

HEAD UNIT ADAPTER:
ACC-HU-PI01, SON1, KEN1, KEN2, ALP1

WELCOME

Congratulations on the purchase of your iDatalink Maestro RR Radio replacement solution. You are now a few simple steps away from enjoying your new car radio with enhanced features.

Before starting your installation, please ensure that your iDatalink Maestro module is programmed with the correct firmware for your vehicle and that you carefully review the install guide.

Please note that Maestro RR will only retain functionalities that were originally available in the vehicle.

TABLE OF CONTENTS

Installation Instructions	3
Wiring Diagram	4
Radio Wire Reference Chart	5
Module Diagnostics	6
Troubleshooting Table	7

NEED HELP?

 1 866 427-2999

 maestro.support@idatalink.com

INSTALLATION INSTRUCTIONS P1/1

STEP 1

Remove the factory radio

If using head unit adapter (sold separately), connect HRR-T01 harness to adapter and skip to step 2.

- Unbox the aftermarket radio and locate its main harness.
- Cut and remove the black 20 pin connector from the HRR-T01 T-harness and connect the wires, shown in the wiring diagram, from aftermarket radio main harness to the HRR-T01 T-harness and match the wire functions.

Note: only connect purple/white wire to radio reverse input or module damage will occur.

STEP 2

- Identify if your vehicle has a 20 or 28 pin secondary connector.
- Assemble T01 T-harness as shown on wiring diagram.
- Connect the factory harness to the HRR-T01 harness.

STEP 3

- Connect HRR-T01 3-pin black connector to black connector of OBDII extension harness.
- Plug the OBDII connector into the OBDII of the vehicle.

STEP 4

- Plug the harnesses into the aftermarket radio.
- Plug the Data cable to the data port of the aftermarket radio.
- Insert the Audio cable into the iDatalink 3.5 mm audio jack of the aftermarket radio (if there is no iDatalink audio input, connect to AUX).

Note: On Pioneer radio, ensure that there is nothing plugged into the W/R port.

STEP 5

- Connect all the harnesses to the Maestro RR module then test your installation.

WIRING DIAGRAM *without an Amplifier*

STEP 1

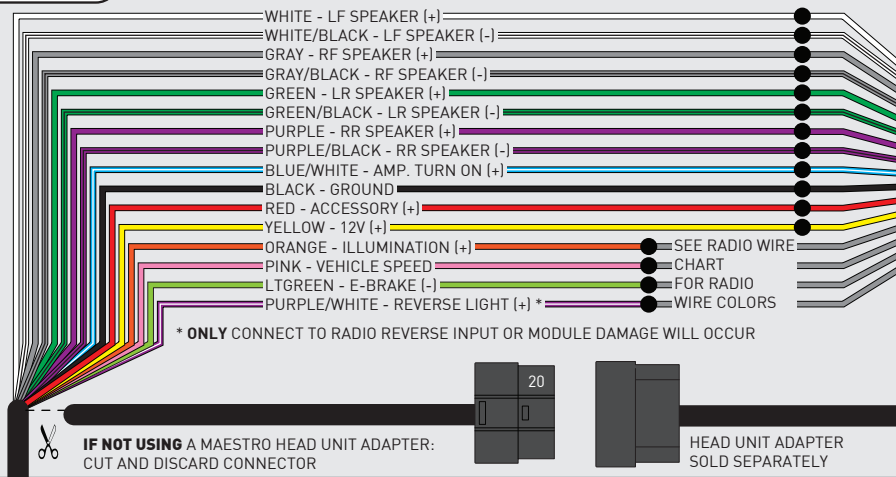

STEP 4

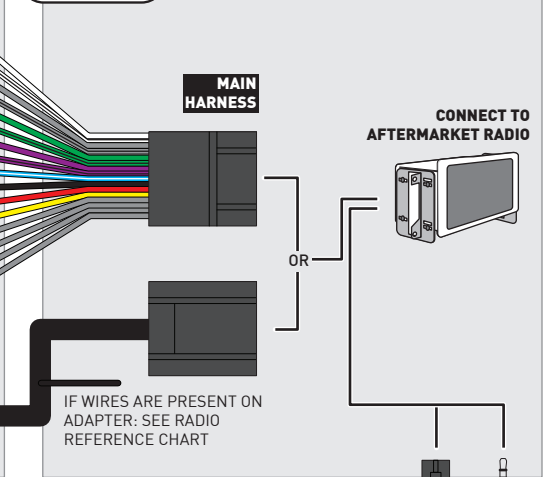

STEP 2

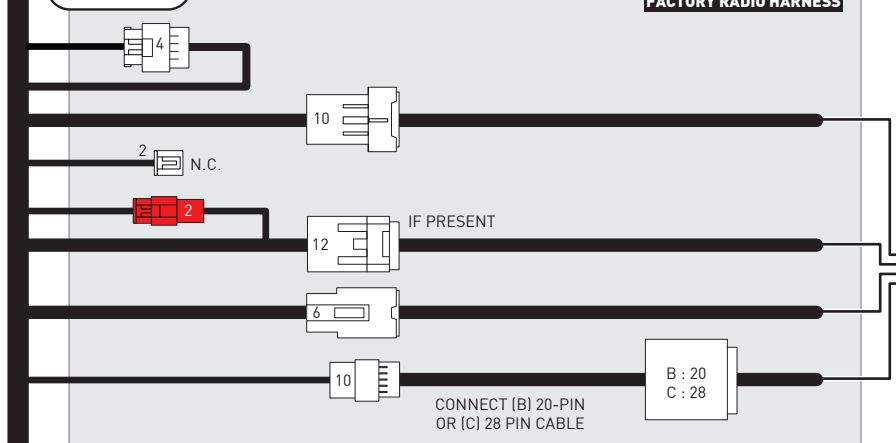

STEP 3

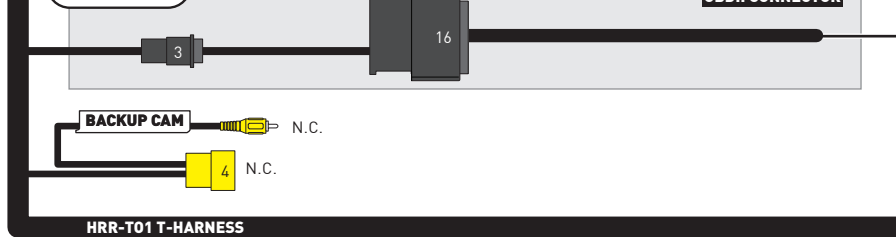

STEP 5

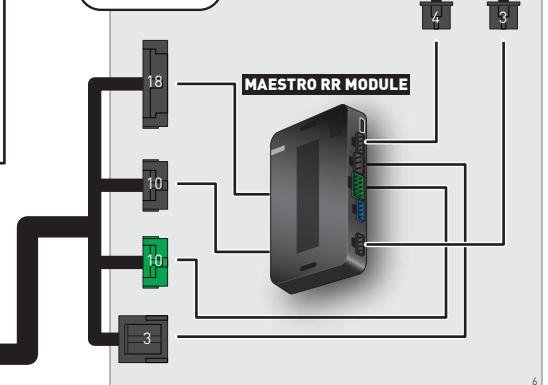

NOT REQUIRED

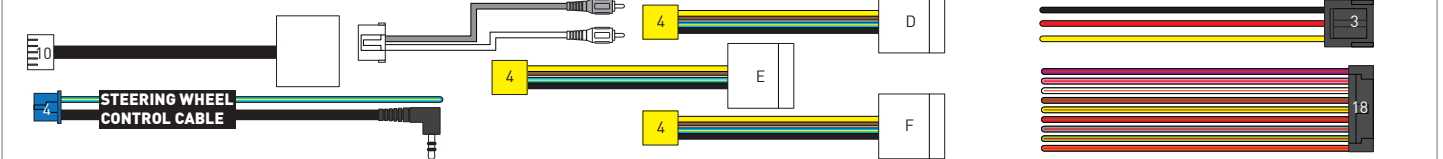

RADIO WIRE REFERENCE CHART

T01 T-harness Wire Description	Polarity	Wire Color on Maestro T-Harness	Wire Color on Alpine cable	Wire Color on Kenwood/JVC cable	Wire Color on Pioneer cable	Wire Color on Sony cable
Illumination	(+)	Orange	N/A	Orange/White	Orange/White	Orange
Reverse Light*	(+)	Purple/White	Orange/White	Purple/White	Purple/White	Purple/White
E-Brake	(-)	Lt Green	Yellow/Blue	Lt Green	Lt Green	Lt Green
VSS (vehicle speed sensor)	(DATA)	Pink	Green/White	Pink	Pink	N/A

Head unit adapter wiring (optional accessory, sold separately)

ACC-HU-ALP1 Wire Description	Polarity	Wire Color on Adapter	Alpine Radio
VSS (vehicle speed sensor)	(DATA)	Green/White	Green/White









ACC-HU-KEN1 Wire Description	Polarity	Wire Color on Adapter	Kenwood Radio
CAM	(+)	Green/Red	Refer to camera/radio manual
CAM	(-)	Green/White	Refer to camera/radio manual
Steering Wheel Controls	(DATA)	Blue/Yellow	n/a

ACC-HU-KEN2 Wire Description	Polarity	Wire Color on Adapter	Kenwood Radio
E-Brake	(-)	LtGreen	LtGreen
Reverse Light*	(+)	Purple/White	Purple/White
Steering Wheel Controls	(DATA)	Blue/Yellow	n/a

* Reverse light wire: Only connect to radio or module damage will occur.

MODULE DIAGNOSTICS



LED 1 Module/Firmware status	LED 2 (RR2) Bluetooth activity	LED STATUS	DIAGNOSTIC
 or 		RED or GREEN flashing	LED flashes 1 or more times, either red or green, when a steering wheel button is pressed : normal operation.
		1 RED flash	Module has no firmware. Flash module using Weblink Desktop and log in. Do <u>NOT</u> use DEMO MODE.
		2 RED flashes	Problem detected. Consult troubleshooting table.
		1 GREEN flash	After radio boots up : Normal operation.
		3 GREEN flashes	Bluetooth is activated. Turns off after one minute: Normal operation.
		OFF	Normal operation (inactive).

VIDEO HELP		Installation, product information, vehicle specific videos.
VERIFY FLASH		Last flash information, steering control configuration, vehicle information.
WEBLINK		Software to program module.

TROUBLESHOOTING TABLE

PROBLEM	SOLUTION
Gauges do not work, radio shows OBD2 Error 1 or Error 2.	<p>Ensure OBDII connector is securely attached to the OBDII connector of the vehicle.</p> <p>If you hardwired connections at the OBDII, check connections at the OBDII connector. Make sure the RED/BROWN wire is on PIN 6 and the YELLOW/BROWN wire is connected to PIN 14 of the OBDII connector. Do not use T-Taps. Soldering or military splicing methods are recommended.</p> <p>If anything else is connected to the OBD2 or CAN wires of vehicle (programmer, throttle controller, insurance tracker, etc.) try unplugging it to see if gauges work. If gauges work without it installed, call tech support for options.</p> <p>Reset the RR.</p>
The light on the Maestro is blinking RED TWICE and the radio IS turning on.	<p>Ensure the 4-pin data cable is connected between the radio and the RR, and that it is plugged into the black port on the Maestro RR. The red and blue ports on the RR should be empty.</p> <p>Make sure the correct radio model and serial number were entered during the flash. Verify the radio's serial number entered during the flash matches what is listed on the radio screen. This can be found in the settings of the radio, listed as Device Id, Device Number, or Serial Number.</p>
The light on the Maestro is blinking RED TWICE but the radio is NOT turning on.	<p>If installing a modular radio and it is not turning on, ensure the screen is secured and any trim pieces on the radio have been installed fully. Not installing these fully will prevent radio from powering up and show a 2x red error as well.</p> <p>Test red and yellow wires for DC voltage at radio using a multimeter. Contact support if no voltage on red or yellow.</p>
The steering wheel controls are not working, the Maestro RR does not blink when they are pressed.	<p>Ensure the 20 or 28-pin connector is plugged to the vehicle and to the T01 T-harness, as shown in step 3 (this is where the RR gets the steering wheel signal from the vehicle).</p>
(Prius only) After the car is turned off, the radio stays on. The car stays in accessory mode and will not turn off.	<p>Locate the white 12-pin connector of the T01 harness, it is connected to the vehicle harness.</p> <p>Then, cut and isolate the red wire located at pin 11. The radio will shut off when the vehicle is turned off.</p>

MAESTRO RR RESET PROCEDURE:

Turn the key to the OFF position, then disconnect all connectors from the module.

Press and hold the module's programming button and connect all the connectors back to the module. Wait, the module's LED will flash RED rapidly (this may take up to 10 seconds).

Release the programming button. Wait, the LED will turn solid GREEN for 2 seconds to show the reset was successful.

TECHNICAL ASSISTANCE

Phone: 1-866-427-2999

Email: maestro.support@idatalink.com

IMPORTANT: To ensure proper operation, the aftermarket radio needs to have the latest firmware from the manufacturer. Please visit the radio manufacturer's website and look for any updates pertaining to your radio.

RETAINS STEERING WHEEL CONTROLS, FACTORY AMPLIFIER, AND MORE!



PRODUCTS REQUIRED

iDatalink Maestro RR or RR2 Radio Replacement Interface
iDatalink Maestro HRR-T01 Installation Harness

PROGRAMMED FIRMWARE

ADS-RR(SR)-TOY01-DS

ADDITIONAL RESOURCES

[Maestro RR2 Programmable Outputs Guide](#)

OPTIONAL ACCESSORIES

K40
ELECTRONICS
ESCORT

Click here for:
[Radar Installation Guides](#)

HEAD UNIT ADAPTER:
ACC-HU-PI01, SON1, KEN1, KEN2, ALP1

WELCOME

Congratulations on the purchase of your iDatalink Maestro RR Radio replacement solution. You are now a few simple steps away from enjoying your new car radio with enhanced features.

Before starting your installation, please ensure that your iDatalink Maestro module is programmed with the correct firmware for your vehicle and that you carefully review the install guide.

Please note that Maestro RR will only retain functionalities that were originally available in the vehicle.

TABLE OF CONTENTS

Installation Instructions	3
Wiring Diagram	4
Radio Wire Reference Chart	5
Module Diagnostics	6
Troubleshooting Table	7

NEED HELP?

 1 866 427-2999

 maestro.support@idatalink.com

INSTALLATION INSTRUCTIONS P1/1

STEP 1

Remove the factory radio

If using head unit adapter (sold separately), connect HRR-T01 harness to adapter and skip to step 2.

- Unbox the aftermarket radio and locate its main harness.
- Cut and remove the black 20 pin connector from the HRR-T01 T-harness and connect the wires, shown in the wiring diagram, from aftermarket radio main harness to the HRR-T01 T-harness and match the wire functions.

Note: only connect purple/white wire to radio reverse input or module damage will occur.

STEP 2

- If the vehicle is equipped with an OEM backup camera, connect the HRR-T01 harness to appropriate HRR adapter cable (D, E or F) then connect to the backup camera harness.

STEP 3

- Identify if your vehicle has a 20 or 28 pin secondary connector.
- Assemble T01 T-harness as shown on wiring diagram.
- Connect the factory harness to the HRR-T01 harness.

STEP 4

- Connect HRR-T01 3-pin black connector to black connector of OBDII extension harness.
- Plug the OBDII connector into the OBDII of the vehicle.

STEP 5

- Plug the harnesses into the aftermarket radio.
- Connect the backup camera RCA cable into the aftermarket radio (if equipped).
- Plug the Data cable to the data port of the aftermarket radio.
- Insert the Audio cable into the iDatalink 3.5 mm audio jack of the aftermarket radio (if there is no iDatalink audio input, connect to AUX).

Note: On Pioneer radio, ensure that there is nothing plugged into the W/R port.

STEP 6

- Connect all the harnesses to the Maestro RR module then test your installation.

WIRING DIAGRAM *without an Amplifier*

STEP 1

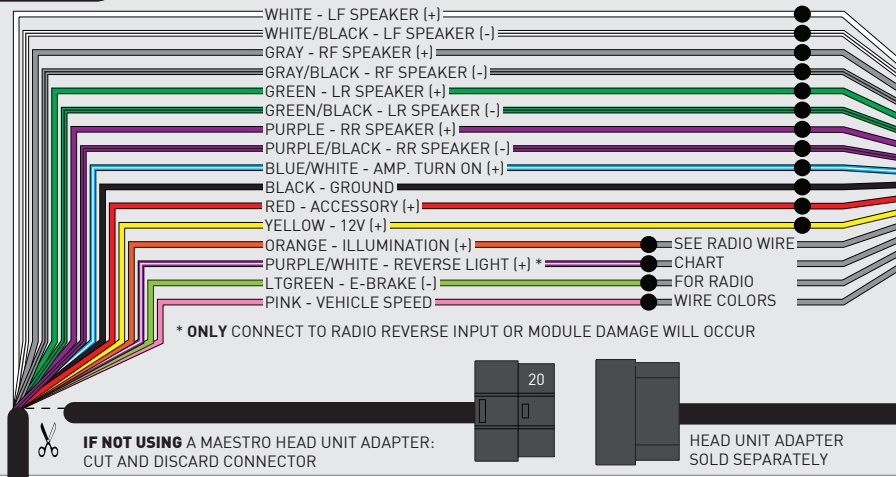

STEP 5

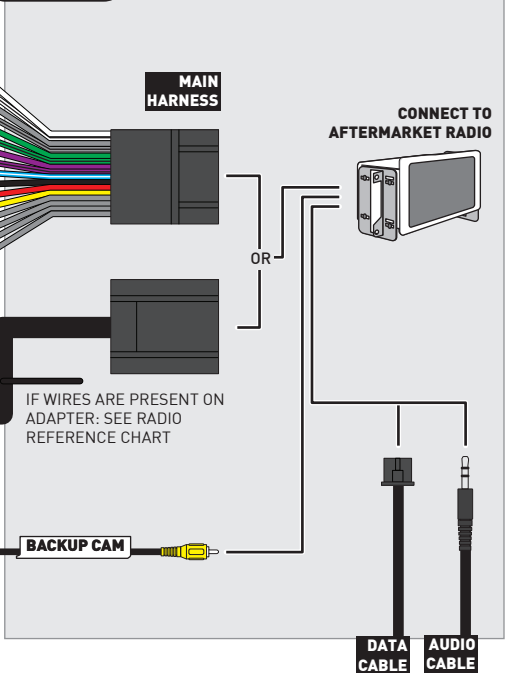

STEP 2

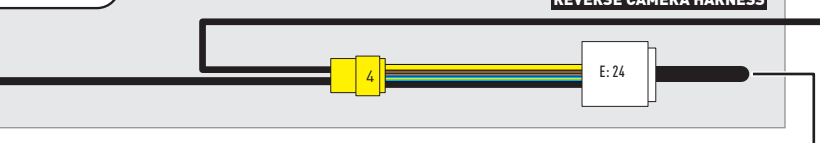

STEP 3

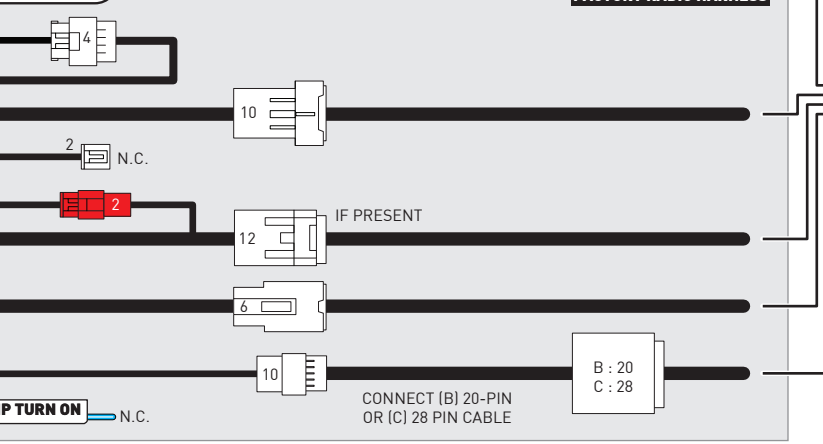

STEP 4



STEP 6

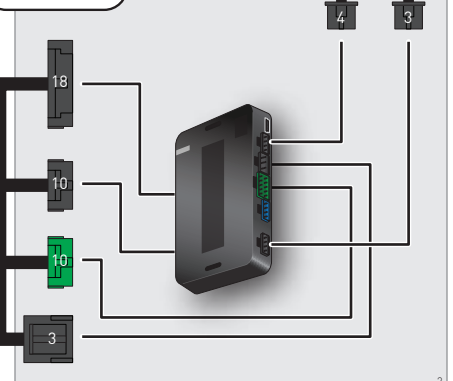

NOT REQUIRED

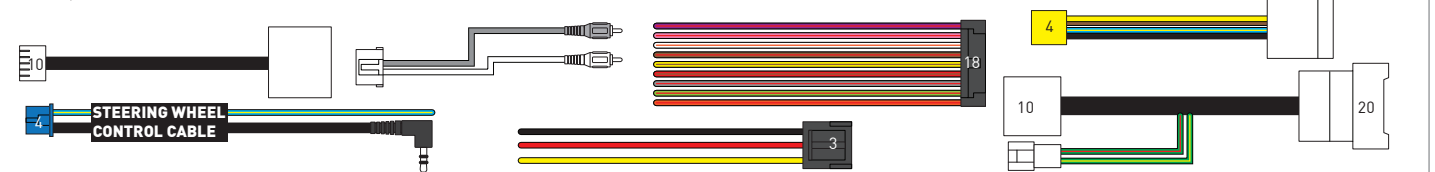

RADIO WIRE REFERENCE CHART

T01 T-harness Wire Description	Polarity	Wire Color on Maestro T-Harness	Wire Color on Alpine cable	Wire Color on Kenwood/JVC cable	Wire Color on Pioneer cable	Wire Color on Sony cable
Illumination	(+)	Orange	N/A	Orange/White	Orange/White	Orange
Reverse Light*	(+)	Purple/White	Orange/White	Purple/White	Purple/White	Purple/White
E-Brake	(-)	Lt Green	Yellow/Blue	Lt Green	Lt Green	Lt Green
VSS (vehicle speed sensor)	(DATA)	Pink	Green/White	Pink	Pink	N/A

Head unit adapter wiring (optional accessory, sold separately)

ACC-HU-ALP1 Wire Description	Polarity	Wire Color on Adapter	Alpine Radio
VSS (vehicle speed sensor)	(DATA)	Green/White	Green/White

ACC-HU-KEN1 Wire Description	Polarity	Wire Color on Adapter	Kenwood Radio
CAM	(+)	Green/Red	Refer to camera/radio manual
CAM	(-)	Green/White	Refer to camera/radio manual
Steering Wheel Controls	(DATA)	Blue/Yellow	n/a

ACC-HU-KEN2 Wire Description	Polarity	Wire Color on Adapter	Kenwood Radio
E-Brake	(-)	LtGreen	LtGreen
Reverse Light*	(+)	Purple/White	Purple/White
Steering Wheel Controls	(DATA)	Blue/Yellow	n/a

* Reverse light wire: Only connect to radio or module damage will occur.

MODULE DIAGNOSTICS



LED 1 Module/Firmware status	LED 2 (RR2) Bluetooth activity	LED STATUS	DIAGNOSTIC
or		RED or GREEN flashing	LED flashes 1 or more times, either red or green, when a steering wheel button is pressed : normal operation.
		1 RED flash	Module has no firmware. Flash module using Weblink Desktop and log in. Do <u>NOT</u> use DEMO MODE.
		2 RED flashes	Problem detected. Consult troubleshooting table.
		1 GREEN flash	After radio boots up : Normal operation.
		3 GREEN flashes	Bluetooth is activated. Turns off after one minute: Normal operation.
		OFF	Normal operation (inactive).

VIDEO HELP		Installation, product information, vehicle specific videos.
VERIFY FLASH		Last flash information, steering control configuration, vehicle information.
WEBLINK		Software to program module.

TROUBLESHOOTING TABLE

PROBLEM	SOLUTION
Gauges do not work, radio shows OBD2 Error 1 or Error 2.	<p>Ensure OBDII connector is securely attached to the OBDII connector of the vehicle.</p> <p>If you hardwired connections at the OBDII, check connections at the OBDII connector. Make sure the RED/BROWN wire is on PIN 6 and the YELLOW/BROWN wire is connected to PIN 14 of the OBDII connector. Do not use T-Taps. Soldering or military splicing methods are recommended.</p> <p>If anything else is connected to the OBD2 or CAN wires of vehicle (programmer, throttle controller, insurance tracker, etc.) try unplugging it to see if gauges work. If gauges work without it installed, call tech support for options.</p> <p>Reset the RR.</p>
The light on the Maestro is blinking RED TWICE and the radio IS turning on.	<p>Ensure the 4-pin data cable is connected between the radio and the RR, and that it is plugged into the black port on the Maestro RR. The red and blue ports on the RR should be empty.</p> <p>Make sure the correct radio model and serial number were entered during the flash. Verify the radio's serial number entered during the flash matches what is listed on the radio screen. This can be found in the settings of the radio, listed as Device Id, Device Number, or Serial Number.</p>
The light on the Maestro is blinking RED TWICE but the radio is NOT turning on.	<p>If installing a modular radio and it is not turning on, ensure the screen is secured and any trim pieces on the radio have been installed fully. Not installing these fully will prevent radio from powering up and show a 2x red error as well.</p> <p>Test red and yellow wires for DC voltage at radio using a multimeter. Contact support if no voltage on red or yellow.</p>
The steering wheel controls are not working, the Maestro RR does not blink when they are pressed.	<p>Ensure the 20 or 28-pin connector is plugged to the vehicle and to the T01 T-harness, as shown in step 3 (this is where the RR gets the steering wheel signal from the vehicle).</p>
(Prius only) After the car is turned off, the radio stays on. The car stays in accessory mode and will not turn off.	<p>Locate the white 12-pin connector of the T01 harness, it is connected to the vehicle harness.</p> <p>Then, cut and isolate the red wire located at pin 11. The radio will shut off when the vehicle is turned off.</p>

MAESTRO RR RESET PROCEDURE:

Turn the key to the OFF position, then disconnect all connectors from the module.

Press and hold the module's programming button and connect all the connectors back to the module. Wait, the module's LED will flash RED rapidly (this may take up to 10 seconds).

Release the programming button. Wait, the LED will turn solid GREEN for 2 seconds to show the reset was successful.

TECHNICAL ASSISTANCE

Phone: 1-866-427-2999

Email: maestro.support@idatalink.com

IMPORTANT: To ensure proper operation, the aftermarket radio needs to have the latest firmware from the manufacturer. Please visit the radio manufacturer's website and look for any updates pertaining to your radio.

RETAINS STEERING WHEEL CONTROLS, FACTORY AMPLIFIER, AND MORE!



PRODUCTS REQUIRED

iDatalink Maestro RR or RR2 Radio Replacement Interface
iDatalink Maestro HRR-T01 Installation Harness

PROGRAMMED FIRMWARE

ADS-RR(SR)-TOY01-DS

ADDITIONAL RESOURCES

[Maestro RR2 Programmable Outputs Guide](#)

OPTIONAL ACCESSORIES

K40[™]
ELECTRONICS
ESCORT

Click here for:
[Radar Installation Guides](#)

HEAD UNIT ADAPTER:
ACC-HU-PI01, SON1, KEN1, KEN2, ALP1

WELCOME

Congratulations on the purchase of your iDatalink Maestro RR Radio replacement solution. You are now a few simple steps away from enjoying your new car radio with enhanced features.

Before starting your installation, please ensure that your iDatalink Maestro module is programmed with the correct firmware for your vehicle and that you carefully review the install guide.

Please note that Maestro RR will only retain functionalities that were originally available in the vehicle.

TABLE OF CONTENTS

Installation Instructions	3
Wiring Diagram	4
Radio Wire Reference Chart	5
Module Diagnostics	6
Troubleshooting Table	7

NEED HELP?

 1 866 427-2999

 maestro.support@idatalink.com

INSTALLATION INSTRUCTIONS P1/1

STEP 1

Remove the factory radio

If using head unit adapter (sold separately), connect HRR-T01 harness to adapter and skip to step 2.

- Unbox the aftermarket radio and locate its main harness.
- Cut and remove the black 20 pin connector from the HRR-T01 T-harness and connect the wires, shown in the wiring diagram, from aftermarket radio main harness to the HRR-T01 T-harness and match the wire functions.

Note: only connect purple/white wire to radio reverse input or module damage will occur.

STEP 2

- Identify if your vehicle has a 20 or 28 pin secondary connector.
- Assemble T01 T-harness as shown on wiring diagram.
- Connect the factory harness to the HRR-T01 harness.

STEP 3

- Connect HRR-T01 3-pin black connector to black connector of OBDII extension harness.
- Plug the OBDII connector into the OBDII of the vehicle.

STEP 4

- Plug the harnesses into the aftermarket radio.
- Connect the left front and right front low level outputs RCA cables into the aftermarket radio.
- Plug the Data cable to the data port of the aftermarket radio.
- Insert the Audio cable into the iDatalink 3.5 mm audio jack of the aftermarket radio (if there is no iDatalink audio input, connect to AUX).

Note: On Pioneer radio, ensure that there is nothing plugged into the W/R port.

STEP 5

- Connect all the harnesses to the Maestro RR module then test your installation.

WIRING DIAGRAM *with an Amplifier*

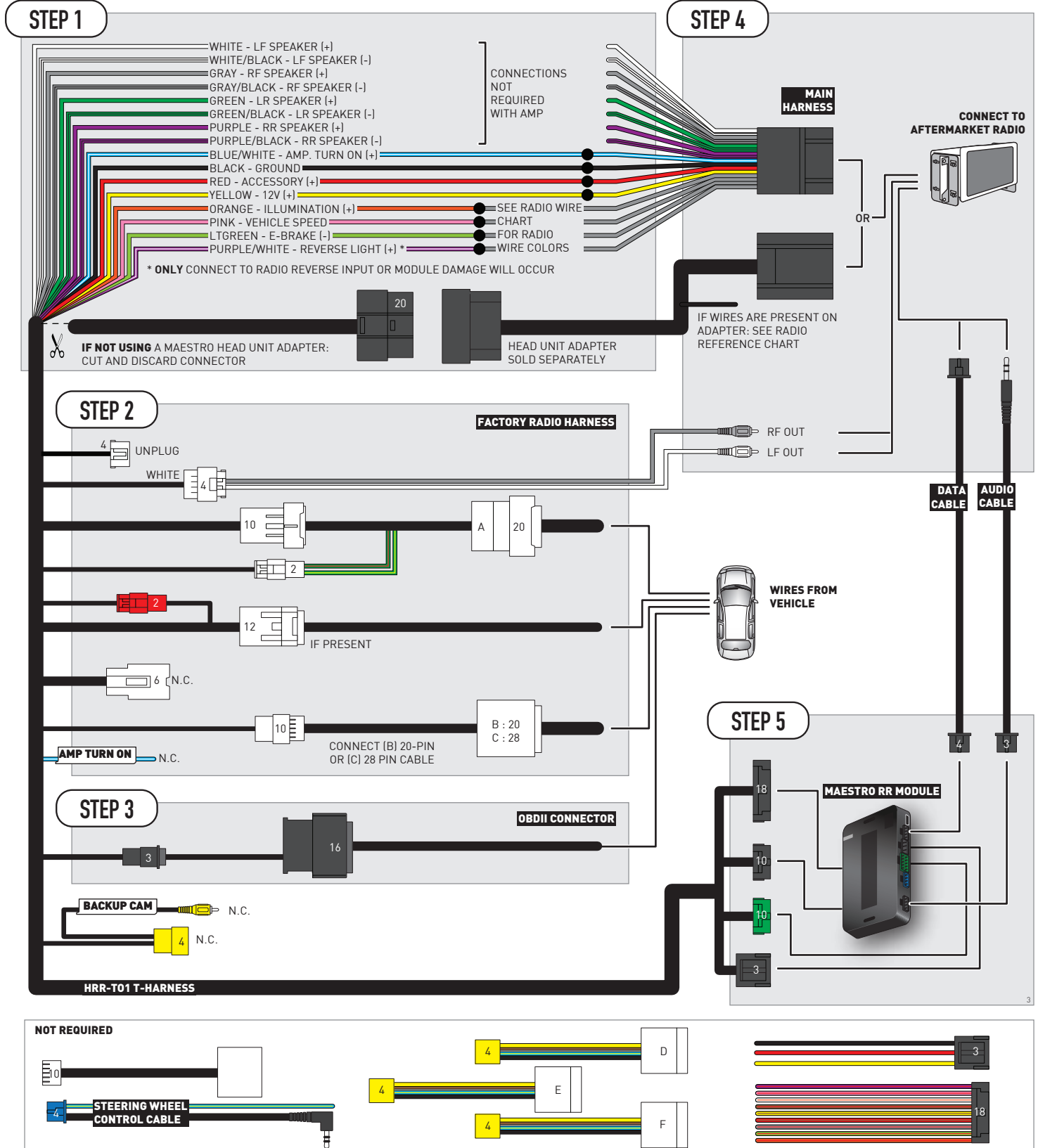

RADIO WIRE REFERENCE CHART

T01 T-harness Wire Description	Polarity	Wire Color on Maestro T-Harness	Wire Color on Alpine cable	Wire Color on Kenwood/ JVC cable	Wire Color on Pioneer cable	Wire Color on Sony cable
Illumination	(+)	Orange	N/A	Orange/White	Orange/White	Orange
Reverse Light*	(+)	Purple/White	Orange/White	Purple/White	Purple/White	Purple/White
E-Brake	(-)	Lt Green	Yellow/Blue	Lt Green	Lt Green	Lt Green
VSS (vehicle speed sensor)	(DATA)	Pink	Green/White	Pink	Pink	N/A

Head unit adapter wiring (optional accessory, sold separately)

ACC-HU-ALP1 Wire Description	Polarity	Wire Color on Adapter	Alpine Radio
VSS (vehicle speed sensor)	(DATA)	Green/White	Green/White

ACC-HU-KEN1 Wire Description	Polarity	Wire Color on Adapter	Kenwood Radio
CAM	(+)	Green/Red	Refer to camera/radio manual
CAM	(-)	Green/White	Refer to camera/radio manual
Steering Wheel Controls	(DATA)	Blue/Yellow	n/a

ACC-HU-KEN2 Wire Description	Polarity	Wire Color on Adapter	Kenwood Radio
E-Brake	(-)	LtGreen	LtGreen
Reverse Light*	(+)	Purple/White	Purple/White
Steering Wheel Controls	(DATA)	Blue/Yellow	n/a

* Reverse light wire: Only connect to radio or module damage will occur.

MODULE DIAGNOSTICS



LED 1 Module/Firmware status	LED 2 (RR2) Bluetooth activity	LED STATUS	DIAGNOSTIC
or		RED or GREEN flashing	LED flashes 1 or more times, either red or green, when a steering wheel button is pressed : normal operation.
		1 RED flash	Module has no firmware. Flash module using Weblink Desktop and log in. Do <u>NOT</u> use DEMO MODE.
		2 RED flashes	Problem detected. Consult troubleshooting table.
		1 GREEN flash	After radio boots up : Normal operation.
		3 GREEN flashes	Bluetooth is activated. Turns off after one minute: Normal operation.
		OFF	Normal operation (inactive).

VIDEO HELP		Installation, product information, vehicle specific videos.
VERIFY FLASH		Last flash information, steering control configuration, vehicle information.
WEBLINK		Software to program module.

TROUBLESHOOTING TABLE

PROBLEM	SOLUTION
Gauges do not work, radio shows OBD2 Error 1 or Error 2.	<p>Ensure OBDII connector is securely attached to the OBDII connector of the vehicle.</p> <p>If you hardwired connections at the OBDII, check connections at the OBDII connector. Make sure the RED/BROWN wire is on PIN 6 and the YELLOW/BROWN wire is connected to PIN 14 of the OBDII connector. Do not use T-Taps. Soldering or military splicing methods are recommended.</p> <p>If anything else is connected to the OBD2 or CAN wires of vehicle (programmer, throttle controller, insurance tracker, etc.) try unplugging it to see if gauges work. If gauges work without it installed, call tech support for options.</p> <p>Reset the RR.</p>
The light on the Maestro is blinking RED TWICE and the radio IS turning on.	<p>Ensure the 4-pin data cable is connected between the radio and the RR, and that it is plugged into the black port on the Maestro RR. The red and blue ports on the RR should be empty.</p> <p>Make sure the correct radio model and serial number were entered during the flash. Verify the radio's serial number entered during the flash matches what is listed on the radio screen. This can be found in the settings of the radio, listed as Device Id, Device Number, or Serial Number.</p>
The light on the Maestro is blinking RED TWICE but the radio is NOT turning on.	<p>If installing a modular radio and it is not turning on, ensure the screen is secured and any trim pieces on the radio have been installed fully. Not installing these fully will prevent radio from powering up and show a 2x red error as well.</p> <p>Test red and yellow wires for DC voltage at radio using a multimeter. Contact support if no voltage on red or yellow.</p>
The steering wheel controls are not working, the Maestro RR does not blink when they are pressed.	<p>Ensure the 20 or 28-pin connector is plugged to the vehicle and to the T01 T-harness, as shown in step 3 (this is where the RR gets the steering wheel signal from the vehicle).</p>
(Prius only) After the car is turned off, the radio stays on. The car stays in accessory mode and will not turn off.	<p>Locate the white 12-pin connector of the T01 harness, it is connected to the vehicle harness.</p> <p>Then, cut and isolate the red wire located at pin 11. The radio will shut off when the vehicle is turned off.</p>

MAESTRO RR RESET PROCEDURE:

Turn the key to the OFF position, then disconnect all connectors from the module.

Press and hold the module's programming button and connect all the connectors back to the module. Wait, the module's LED will flash RED rapidly (this may take up to 10 seconds).

Release the programming button. Wait, the LED will turn solid GREEN for 2 seconds to show the reset was successful.

TECHNICAL ASSISTANCE

Phone: 1-866-427-2999

Email: maestro.support@idatalink.com

IMPORTANT: To ensure proper operation, the aftermarket radio needs to have the latest firmware from the manufacturer. Please visit the radio manufacturer's website and look for any updates pertaining to your radio.

RETAINS STEERING WHEEL CONTROLS, FACTORY AMPLIFIER, AND MORE!



PRODUCTS REQUIRED

iDatalink Maestro RR or RR2 Radio Replacement Interface
iDatalink Maestro HRR-T01 Installation Harness

PROGRAMMED FIRMWARE

ADS-RR(SR)-TOY01-DS

ADDITIONAL RESOURCES

[Maestro RR2 Programmable Outputs Guide](#)

OPTIONAL ACCESSORIES

K40[™]
ELECTRONICS
ESCORT

Click here for:
[Radar Installation Guides](#)

HEAD UNIT ADAPTER:
ACC-HU-PI01, SON1, KEN1, KEN2, ALP1

WELCOME

Congratulations on the purchase of your iDatalink Maestro RR Radio replacement solution. You are now a few simple steps away from enjoying your new car radio with enhanced features.

Before starting your installation, please ensure that your iDatalink Maestro module is programmed with the correct firmware for your vehicle and that you carefully review the install guide.

Please note that Maestro RR will only retain functionalities that were originally available in the vehicle.

TABLE OF CONTENTS

Installation Instructions	3
Wiring Diagram	4
Radio Wire Reference Chart	5
Module Diagnostics	6
Troubleshooting Table	7

NEED HELP?

 1 866 427-2999

 maestro.support@idatalink.com

INSTALLATION INSTRUCTIONS P1/1

STEP 1

Remove the factory radio

If using head unit adapter (sold separately), connect HRR-T01 harness to adapter and skip to step 2.

- Unbox the aftermarket radio and locate its main harness.
- Cut and remove the black 20 pin connector from the HRR-T01 T-harness and connect the wires, shown in the wiring diagram, from aftermarket radio main harness to the HRR-T01 T-harness and match the wire functions.

Note: only connect purple/white wire to radio reverse input or module damage will occur.

STEP 2

- Identify if your vehicle has a 20 or 28 pin secondary connector.
- Assemble T01 T-harness as shown on wiring diagram.
- Connect the factory harness to the HRR-T01 harness.

STEP 3

- Connect HRR-T01 3-pin black connector to black connector of OBDII extension harness.
- Plug the OBDII connector into the OBDII of the vehicle.

STEP 4

- Plug the harnesses into the aftermarket radio.
- Plug the Data cable to the data port of the aftermarket radio.
- Insert the Audio cable into the iDatalink 3.5 mm audio jack of the aftermarket radio (if there is no iDatalink audio input, connect to AUX).

Note: On Pioneer radio, ensure that there is nothing plugged into the W/R port.

STEP 5

- Connect all the harnesses to the Maestro RR module then test your installation.

WIRING DIAGRAM *without an Amplifier*

STEP 1

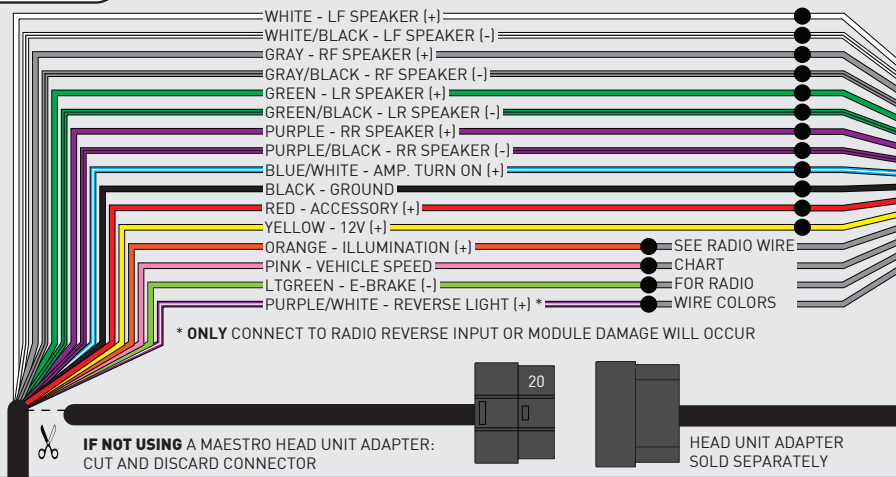

STEP 4

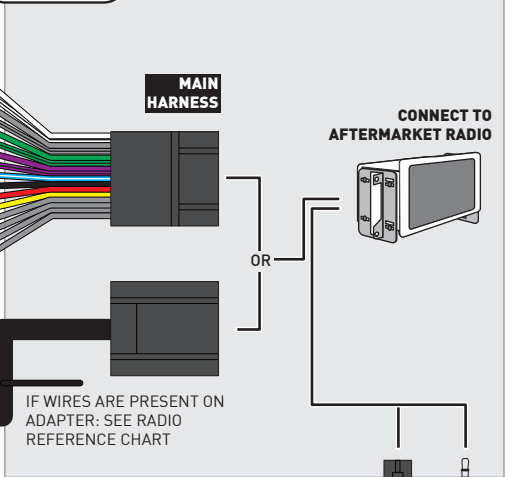

STEP 2

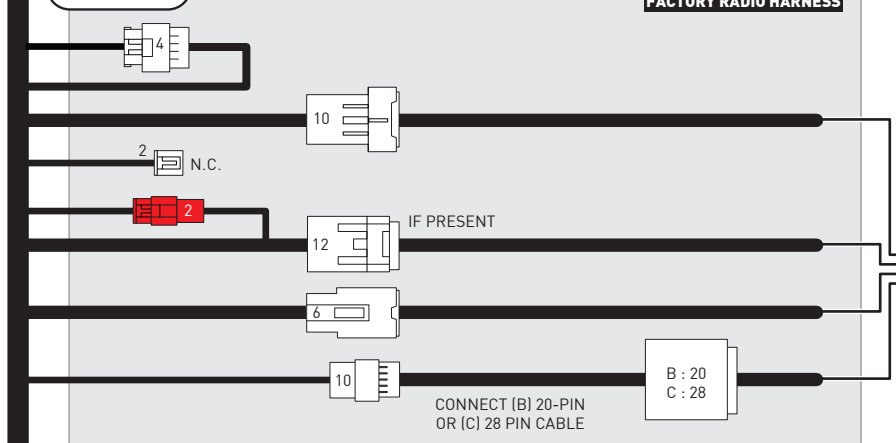

STEP 3

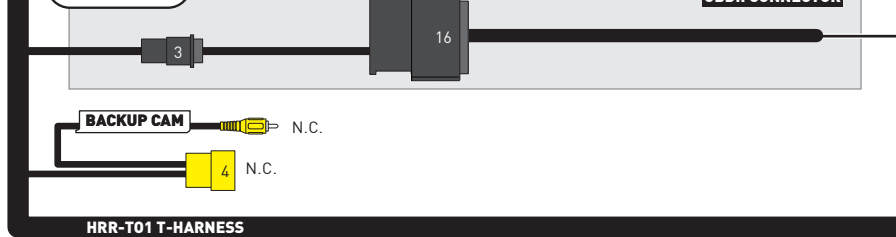

STEP 5

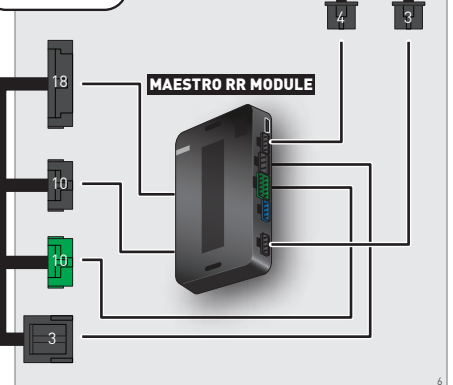

NOT REQUIRED

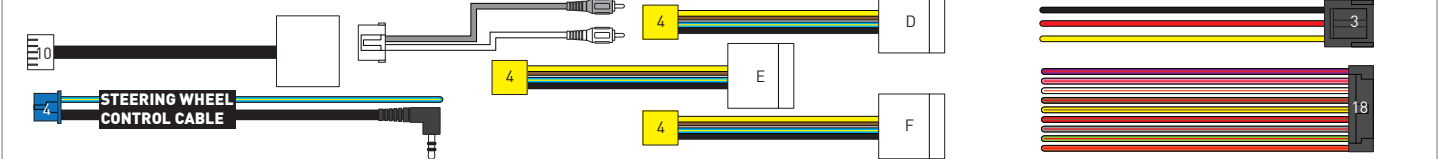

RADIO WIRE REFERENCE CHART

T01 T-harness Wire Description	Polarity	Wire Color on Maestro T-Harness	Wire Color on Alpine cable	Wire Color on Kenwood/ JVC cable	Wire Color on Pioneer cable	Wire Color on Sony cable
Illumination	(+)	Orange	N/A	Orange/White	Orange/White	Orange
Reverse Light*	(+)	Purple/White	Orange/White	Purple/White	Purple/White	Purple/White
E-Brake	(-)	Lt Green	Yellow/Blue	Lt Green	Lt Green	Lt Green
VSS (vehicle speed sensor)	(DATA)	Pink	Green/White	Pink	Pink	N/A

Head unit adapter wiring (optional accessory, sold separately)

ACC-HU-ALP1 Wire Description	Polarity	Wire Color on Adapter	Alpine Radio
VSS (vehicle speed sensor)	(DATA)	Green/White	Green/White

ACC-HU-KEN1 Wire Description	Polarity	Wire Color on Adapter	Kenwood Radio
CAM	(+)	Green/Red	Refer to camera/radio manual
CAM	(-)	Green/White	Refer to camera/radio manual
Steering Wheel Controls	(DATA)	Blue/Yellow	n/a

ACC-HU-KEN2 Wire Description	Polarity	Wire Color on Adapter	Kenwood Radio
E-Brake	(-)	LtGreen	LtGreen
Reverse Light*	(+)	Purple/White	Purple/White
Steering Wheel Controls	(DATA)	Blue/Yellow	n/a

* Reverse light wire: Only connect to radio or module damage will occur.

MODULE DIAGNOSTICS



LED 1 Module/Firmware status	LED 2 (RR2) Bluetooth activity	LED STATUS	DIAGNOSTIC
or		RED or GREEN flashing	LED flashes 1 or more times, either red or green, when a steering wheel button is pressed : normal operation.
		1 RED flash	Module has no firmware. Flash module using Weblink Desktop and log in. Do <u>NOT</u> use DEMO MODE.
		2 RED flashes	Problem detected. Consult troubleshooting table.
		1 GREEN flash	After radio boots up : Normal operation.
		3 GREEN flashes	Bluetooth is activated. Turns off after one minute: Normal operation.
		OFF	Normal operation (inactive).

VIDEO HELP		Installation, product information, vehicle specific videos.
VERIFY FLASH		Last flash information, steering control configuration, vehicle information.
WEBLINK		Software to program module.

TROUBLESHOOTING TABLE

PROBLEM	SOLUTION
Gauges do not work, radio shows OBD2 Error 1 or Error 2.	<p>Ensure OBDII connector is securely attached to the OBDII connector of the vehicle.</p> <p>If you hardwired connections at the OBDII, check connections at the OBDII connector. Make sure the RED/BROWN wire is on PIN 6 and the YELLOW/BROWN wire is connected to PIN 14 of the OBDII connector. Do not use T-Taps. Soldering or military splicing methods are recommended.</p> <p>If anything else is connected to the OBD2 or CAN wires of vehicle (programmer, throttle controller, insurance tracker, etc.) try unplugging it to see if gauges work. If gauges work without it installed, call tech support for options.</p> <p>Reset the RR.</p>
The light on the Maestro is blinking RED TWICE and the radio IS turning on.	<p>Ensure the 4-pin data cable is connected between the radio and the RR, and that it is plugged into the black port on the Maestro RR. The red and blue ports on the RR should be empty.</p> <p>Make sure the correct radio model and serial number were entered during the flash. Verify the radio's serial number entered during the flash matches what is listed on the radio screen. This can be found in the settings of the radio, listed as Device Id, Device Number, or Serial Number.</p>
The light on the Maestro is blinking RED TWICE but the radio is NOT turning on.	<p>If installing a modular radio and it is not turning on, ensure the screen is secured and any trim pieces on the radio have been installed fully. Not installing these fully will prevent radio from powering up and show a 2x red error as well.</p> <p>Test red and yellow wires for DC voltage at radio using a multimeter. Contact support if no voltage on red or yellow.</p>
The steering wheel controls are not working, the Maestro RR does not blink when they are pressed.	<p>Ensure the 20 or 28-pin connector is plugged to the vehicle and to the T01 T-harness, as shown in step 3 (this is where the RR gets the steering wheel signal from the vehicle).</p>
(Prius only) After the car is turned off, the radio stays on. The car stays in accessory mode and will not turn off.	<p>Locate the white 12-pin connector of the T01 harness, it is connected to the vehicle harness.</p> <p>Then, cut and isolate the red wire located at pin 11. The radio will shut off when the vehicle is turned off.</p>

MAESTRO RR RESET PROCEDURE:

Turn the key to the OFF position, then disconnect all connectors from the module.

Press and hold the module's programming button and connect all the connectors back to the module. Wait, the module's LED will flash RED rapidly (this may take up to 10 seconds).

Release the programming button. Wait, the LED will turn solid GREEN for 2 seconds to show the reset was successful.

TECHNICAL ASSISTANCE

Phone: 1-866-427-2999

Email: maestro.support@idatalink.com

IMPORTANT: To ensure proper operation, the aftermarket radio needs to have the latest firmware from the manufacturer. Please visit the radio manufacturer's website and look for any updates pertaining to your radio.

RETAINS STEERING WHEEL CONTROLS, FACTORY AMPLIFIER, AND MORE!



PRODUCTS REQUIRED

iDatalink Maestro RR or RR2 Radio Replacement Interface
iDatalink Maestro HRR-T01 Installation Harness

PROGRAMMED FIRMWARE

ADS-RR(SR)-TOY01-DS

ADDITIONAL RESOURCES

[Maestro RR2 Programmable Outputs Guide](#)

OPTIONAL ACCESSORIES

K40[™]
ELECTRONICS
ESCORT

Click here for:
[Radar Installation Guides](#)

HEAD UNIT ADAPTER:
ACC-HU-PI01, SON1, KEN1, KEN2, ALP1

WELCOME

Congratulations on the purchase of your iDatalink Maestro RR Radio replacement solution. You are now a few simple steps away from enjoying your new car radio with enhanced features.

Before starting your installation, please ensure that your iDatalink Maestro module is programmed with the correct firmware for your vehicle and that you carefully review the install guide.

Please note that Maestro RR will only retain functionalities that were originally available in the vehicle.

TABLE OF CONTENTS

Installation Instructions	3
Wiring Diagram	4
Radio Wire Reference Chart	5
Module Diagnostics	6
Troubleshooting Table	7

NEED HELP?

 1 866 427-2999

 maestro.support@idatalink.com

INSTALLATION INSTRUCTIONS P1/1

STEP 1

Remove the factory radio

If using head unit adapter (sold separately), connect HRR-T01 harness to adapter and skip to step 2.

- Unbox the aftermarket radio and locate its main harness.
- Cut and remove the black 20 pin connector from the HRR-T01 T-harness and connect the wires, shown in the wiring diagram, from aftermarket radio main harness to the HRR-T01 T-harness and match the wire functions.

Note: only connect purple/white wire to radio reverse input or module damage will occur.

STEP 2

- If the vehicle is equipped with an OEM backup camera, connect the HRR-T01 harness to appropriate HRR adapter cable (D, E or F) then connect to the backup camera harness.

STEP 3

- Identify if your vehicle has a 20 or 28 pin secondary connector.
- Assemble T01 T-harness as shown on wiring diagram.
- Connect the factory harness to the HRR-T01 harness.

STEP 4

- Connect HRR-T01 3-pin black connector to black connector of OBDII extension harness.
- Plug the OBDII connector into the OBDII of the vehicle.

STEP 5

- Plug the harnesses into the aftermarket radio.
- Connect the backup camera RCA cable into the aftermarket radio (if equipped).
- Connect the left front and right front low level outputs RCA cables into the aftermarket radio.
- Plug the Data cable to the data port of the aftermarket radio.
- Insert the Audio cable into the iDatalink 3.5 mm audio jack of the aftermarket radio (if there is no iDatalink audio input, connect to AUX).

Note: On Pioneer radio, ensure that there is nothing plugged into the W/R port.

STEP 6

- Connect all the harnesses to the Maestro RR module then test your installation.

WIRING DIAGRAM *with an Amplifier*

STEP 1

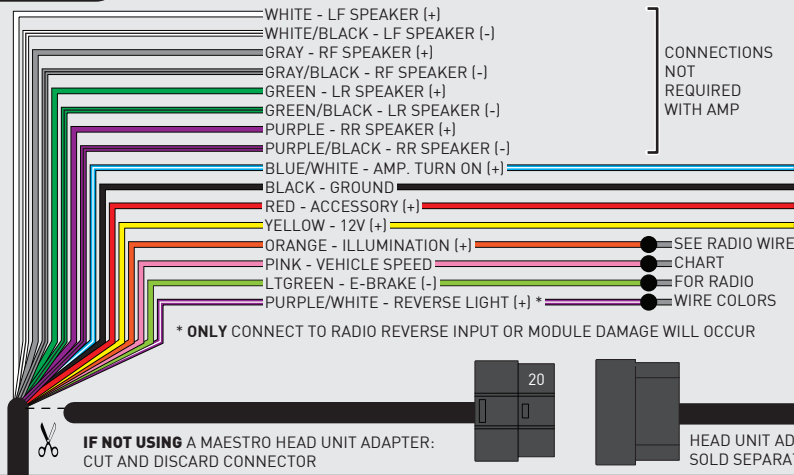

STEP 5

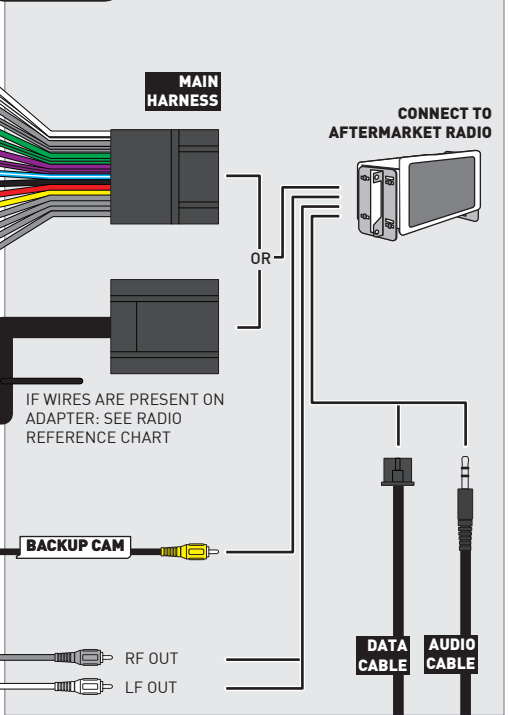

STEP 2

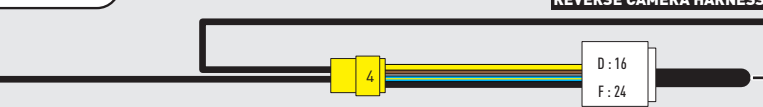

STEP 3

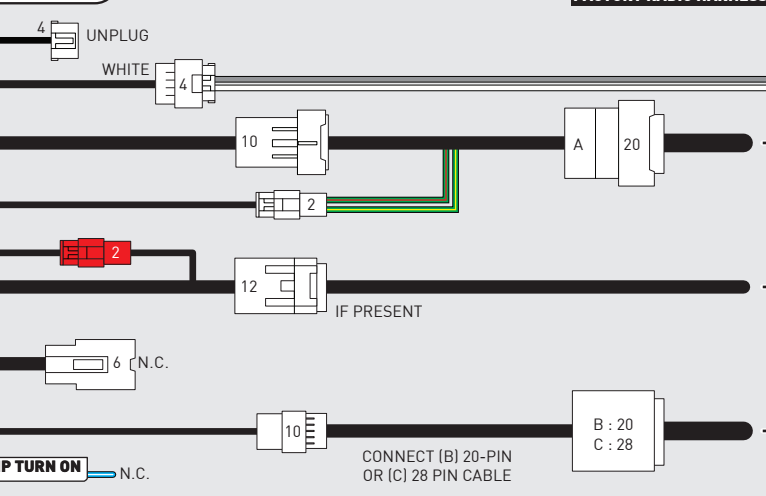

STEP 4



STEP 6

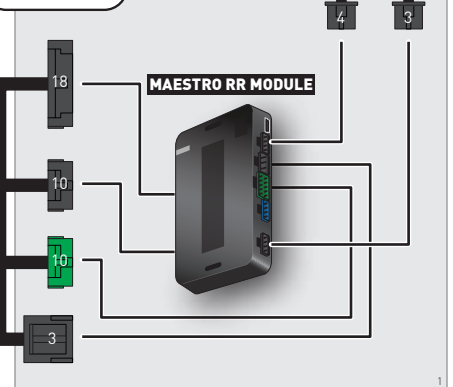

NOT REQUIRED

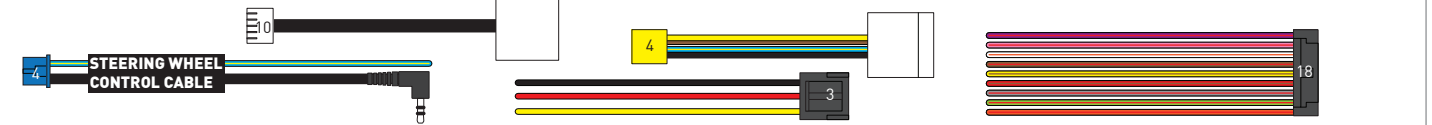

RADIO WIRE REFERENCE CHART

T01 T-harness Wire Description	Polarity	Wire Color on Maestro T-Harness	Wire Color on Alpine cable	Wire Color on Kenwood/JVC cable	Wire Color on Pioneer cable	Wire Color on Sony cable
Illumination	(+)	Orange	N/A	Orange/White	Orange/White	Orange
Reverse Light*	(+)	Purple/White	Orange/White	Purple/White	Purple/White	Purple/White
E-Brake	(-)	Lt Green	Yellow/Blue	Lt Green	Lt Green	Lt Green
VSS (vehicle speed sensor)	(DATA)	Pink	Green/White	Pink	Pink	N/A

Head unit adapter wiring (optional accessory, sold separately)

ACC-HU-ALP1 Wire Description	Polarity	Wire Color on Adapter	Alpine Radio
VSS (vehicle speed sensor)	(DATA)	Green/White	Green/White

ACC-HU-KEN1 Wire Description	Polarity	Wire Color on Adapter	Kenwood Radio
CAM	(+)	Green/Red	Refer to camera/radio manual
CAM	(-)	Green/White	Refer to camera/radio manual
Steering Wheel Controls	(DATA)	Blue/Yellow	n/a

ACC-HU-KEN2 Wire Description	Polarity	Wire Color on Adapter	Kenwood Radio
E-Brake	(-)	LtGreen	LtGreen
Reverse Light*	(+)	Purple/White	Purple/White
Steering Wheel Controls	(DATA)	Blue/Yellow	n/a

* Reverse light wire: Only connect to radio or module damage will occur.

MODULE DIAGNOSTICS



LED 1 Module/Firmware status	LED 2 (RR2) Bluetooth activity	LED STATUS	DIAGNOSTIC
or		RED or GREEN flashing	LED flashes 1 or more times, either red or green, when a steering wheel button is pressed : normal operation.
		1 RED flash	Module has no firmware. Flash module using Weblink Desktop and log in. Do <u>NOT</u> use DEMO MODE.
		2 RED flashes	Problem detected. Consult troubleshooting table.
		1 GREEN flash	After radio boots up : Normal operation.
		3 GREEN flashes	Bluetooth is activated. Turns off after one minute: Normal operation.
		OFF	Normal operation (inactive).

VIDEO HELP		Installation, product information, vehicle specific videos.
VERIFY FLASH		Last flash information, steering control configuration, vehicle information.
WEBLINK		Software to program module.

TROUBLESHOOTING TABLE

PROBLEM	SOLUTION
Gauges do not work, radio shows OBD2 Error 1 or Error 2.	<p>Ensure OBDII connector is securely attached to the OBDII connector of the vehicle.</p> <p>If you hardwired connections at the OBDII, check connections at the OBDII connector. Make sure the RED/BROWN wire is on PIN 6 and the YELLOW/BROWN wire is connected to PIN 14 of the OBDII connector. Do not use T-Taps. Soldering or military splicing methods are recommended.</p> <p>If anything else is connected to the OBD2 or CAN wires of vehicle (programmer, throttle controller, insurance tracker, etc.) try unplugging it to see if gauges work. If gauges work without it installed, call tech support for options.</p> <p>Reset the RR.</p>
The light on the Maestro is blinking RED TWICE and the radio IS turning on.	<p>Ensure the 4-pin data cable is connected between the radio and the RR, and that it is plugged into the black port on the Maestro RR. The red and blue ports on the RR should be empty.</p> <p>Make sure the correct radio model and serial number were entered during the flash. Verify the radio's serial number entered during the flash matches what is listed on the radio screen. This can be found in the settings of the radio, listed as Device Id, Device Number, or Serial Number.</p>
The light on the Maestro is blinking RED TWICE but the radio is NOT turning on.	<p>If installing a modular radio and it is not turning on, ensure the screen is secured and any trim pieces on the radio have been installed fully. Not installing these fully will prevent radio from powering up and show a 2x red error as well.</p> <p>Test red and yellow wires for DC voltage at radio using a multimeter. Contact support if no voltage on red or yellow.</p>
The steering wheel controls are not working, the Maestro RR does not blink when they are pressed.	<p>Ensure the 20 or 28-pin connector is plugged to the vehicle and to the T01 T-harness, as shown in step 3 (this is where the RR gets the steering wheel signal from the vehicle).</p>
(Prius only) After the car is turned off, the radio stays on. The car stays in accessory mode and will not turn off.	<p>Locate the white 12-pin connector of the T01 harness, it is connected to the vehicle harness.</p> <p>Then, cut and isolate the red wire located at pin 11. The radio will shut off when the vehicle is turned off.</p>

MAESTRO RR RESET PROCEDURE:

Turn the key to the OFF position, then disconnect all connectors from the module.

Press and hold the module's programming button and connect all the connectors back to the module. Wait, the module's LED will flash RED rapidly (this may take up to 10 seconds).

Release the programming button. Wait, the LED will turn solid GREEN for 2 seconds to show the reset was successful.

TECHNICAL ASSISTANCE

Phone: 1-866-427-2999

Email: maestro.support@idatalink.com

IMPORTANT: To ensure proper operation, the aftermarket radio needs to have the latest firmware from the manufacturer. Please visit the radio manufacturer's website and look for any updates pertaining to your radio.

2013

TOYOTA HIGHLANDER
WITH JBL

RETAINS STEERING WHEEL CONTROLS, FACTORY AMPLIFIER, AND MORE!



PRODUCTS REQUIRED

iDatalink Maestro RR or RR2 Radio Replacement Interface
iDatalink Maestro HRR-T01 Installation Harness

PROGRAMMED FIRMWARE

ADS-RR(SR)-TOY01-DS

ADDITIONAL RESOURCES

[Maestro RR2 Programmable Outputs Guide](#)

OPTIONAL ACCESSORIES

K40[™]
ELECTRONICS
ESCORT

Click here for:
[Radar Installation Guides](#)

HEAD UNIT ADAPTER:
ACC-HU-PI01, SON1, KEN1, KEN2, ALP1

WELCOME

Congratulations on the purchase of your iDatalink Maestro RR Radio replacement solution. You are now a few simple steps away from enjoying your new car radio with enhanced features.

Before starting your installation, please ensure that your iDatalink Maestro module is programmed with the correct firmware for your vehicle and that you carefully review the install guide.

Please note that Maestro RR will only retain functionalities that were originally available in the vehicle.

TABLE OF CONTENTS

Installation Instructions	3
Wiring Diagram	4
Radio Wire Reference Chart	5
Module Diagnostics	6
Troubleshooting Table	7

NEED HELP?

 1 866 427-2999

 maestro.support@idatalink.com

INSTALLATION INSTRUCTIONS P1/1

STEP 1

Remove the factory radio

If using head unit adapter (sold separately), connect HRR-T01 harness to adapter and skip to step 2.

- Unbox the aftermarket radio and locate its main harness.
- Cut and remove the black 20 pin connector from the HRR-T01 T-harness and connect the wires, shown in the wiring diagram, from aftermarket radio main harness to the HRR-T01 T-harness and match the wire functions.

Note: only connect purple/white wire to radio reverse input or module damage will occur.

STEP 2

- If the vehicle is equipped with an OEM backup camera, connect the HRR-T01 harness to appropriate HRR adapter cable (D, E or F) then connect to the backup camera harness.

STEP 3

- Identify if your vehicle has a 20 or 28 pin secondary connector.
- Assemble T01 T-harness as shown on wiring diagram.
- Connect the factory harness to the HRR-T01 harness.

STEP 4

- Connect HRR-T01 3-pin black connector to black connector of OBDII extension harness.
- Plug the OBDII connector into the OBDII of the vehicle.

STEP 5

- Plug the harnesses into the aftermarket radio.
- Connect the backup camera RCA cable into the aftermarket radio (if equipped).
- Connect the left front and right front low level outputs RCA cables into the aftermarket radio.
- Plug the Data cable to the data port of the aftermarket radio.
- Insert the Audio cable into the iDatalink 3.5 mm audio jack of the aftermarket radio (if there is no iDatalink audio input, connect to AUX).

Note: On Pioneer radio, ensure that there is nothing plugged into the W/R port.

STEP 6

- Connect all the harnesses to the Maestro RR module then test your installation.

WIRING DIAGRAM *with an Amplifier*

STEP 1

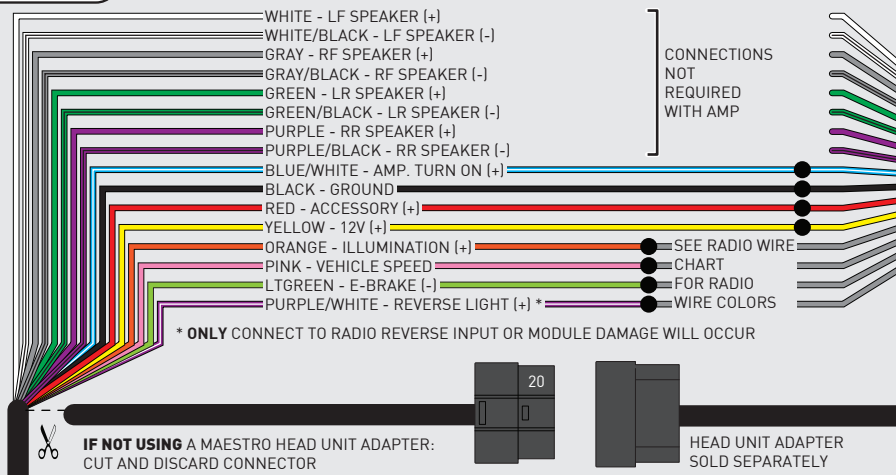

STEP 5

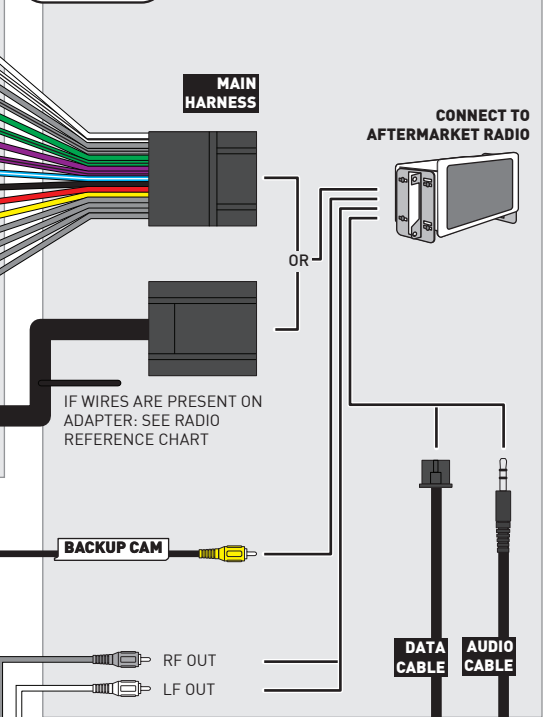

STEP 2

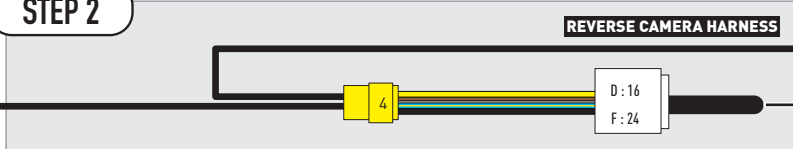

STEP 3

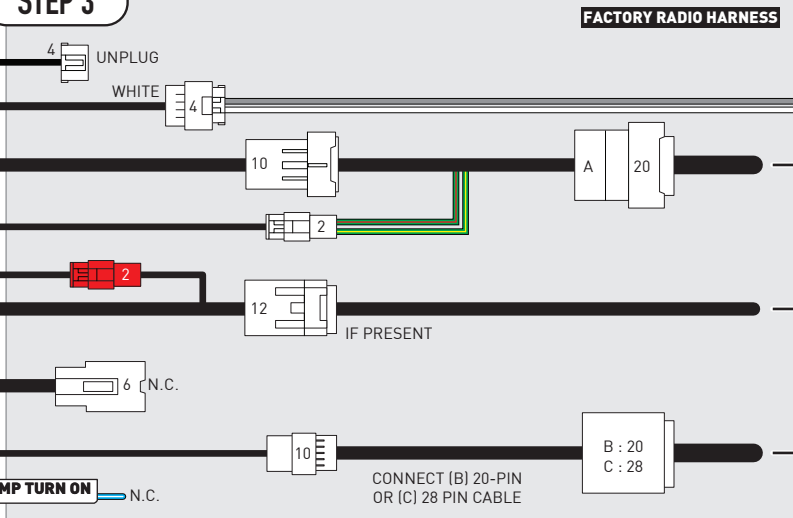

STEP 4

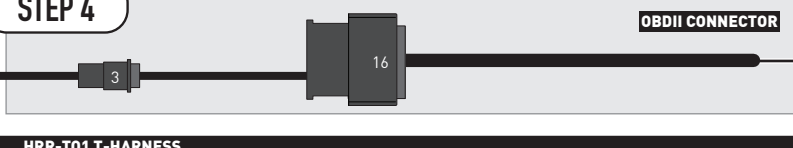

STEP 6

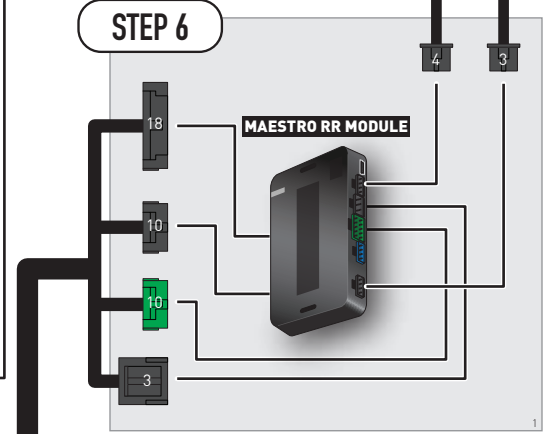

NOT REQUIRED

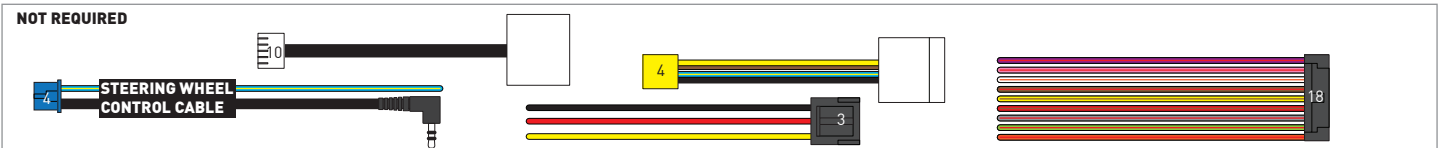

RADIO WIRE REFERENCE CHART

T01 T-harness Wire Description	Polarity	Wire Color on Maestro T-Harness	Wire Color on Alpine cable	Wire Color on Kenwood/JVC cable	Wire Color on Pioneer cable	Wire Color on Sony cable
Illumination	(+)	Orange	N/A	Orange/White	Orange/White	Orange
Reverse Light*	(+)	Purple/White	Orange/White	Purple/White	Purple/White	Purple/White
E-Brake	(-)	Lt Green	Yellow/Blue	Lt Green	Lt Green	Lt Green
VSS (vehicle speed sensor)	(DATA)	Pink	Green/White	Pink	Pink	N/A

Head unit adapter wiring (optional accessory, sold separately)

ACC-HU-ALP1 Wire Description	Polarity	Wire Color on Adapter	Alpine Radio
VSS (vehicle speed sensor)	(DATA)	Green/White	Green/White

ACC-HU-KEN1 Wire Description	Polarity	Wire Color on Adapter	Kenwood Radio
CAM	(+)	Green/Red	Refer to camera/radio manual
CAM	(-)	Green/White	Refer to camera/radio manual
Steering Wheel Controls	(DATA)	Blue/Yellow	n/a

ACC-HU-KEN2 Wire Description	Polarity	Wire Color on Adapter	Kenwood Radio
E-Brake	(-)	LtGreen	LtGreen
Reverse Light*	(+)	Purple/White	Purple/White
Steering Wheel Controls	(DATA)	Blue/Yellow	n/a

* Reverse light wire: Only connect to radio or module damage will occur.

MODULE DIAGNOSTICS



LED 1 Module/Firmware status	LED 2 (RR2) Bluetooth activity	LED STATUS	DIAGNOSTIC
or		RED or GREEN flashing	LED flashes 1 or more times, either red or green, when a steering wheel button is pressed : normal operation.
		1 RED flash	Module has no firmware. Flash module using Weblink Desktop and log in. Do <u>NOT</u> use DEMO MODE.
		2 RED flashes	Problem detected. Consult troubleshooting table.
		1 GREEN flash	After radio boots up : Normal operation.
		3 GREEN flashes	Bluetooth is activated. Turns off after one minute: Normal operation.
		OFF	Normal operation (inactive).

VIDEO HELP		Installation, product information, vehicle specific videos.
VERIFY FLASH		Last flash information, steering control configuration, vehicle information.
WEBLINK		Software to program module.

TROUBLESHOOTING TABLE

PROBLEM	SOLUTION
Gauges do not work, radio shows OBD2 Error 1 or Error 2.	<p>Ensure OBDII connector is securely attached to the OBDII connector of the vehicle.</p> <p>If you hardwired connections at the OBDII, check connections at the OBDII connector. Make sure the RED/BROWN wire is on PIN 6 and the YELLOW/BROWN wire is connected to PIN 14 of the OBDII connector. Do not use T-Taps. Soldering or military splicing methods are recommended.</p> <p>If anything else is connected to the OBD2 or CAN wires of vehicle (programmer, throttle controller, insurance tracker, etc.) try unplugging it to see if gauges work. If gauges work without it installed, call tech support for options.</p> <p>Reset the RR.</p>
The light on the Maestro is blinking RED TWICE and the radio IS turning on.	<p>Ensure the 4-pin data cable is connected between the radio and the RR, and that it is plugged into the black port on the Maestro RR. The red and blue ports on the RR should be empty.</p> <p>Make sure the correct radio model and serial number were entered during the flash. Verify the radio's serial number entered during the flash matches what is listed on the radio screen. This can be found in the settings of the radio, listed as Device Id, Device Number, or Serial Number.</p>
The light on the Maestro is blinking RED TWICE but the radio is NOT turning on.	<p>If installing a modular radio and it is not turning on, ensure the screen is secured and any trim pieces on the radio have been installed fully. Not installing these fully will prevent radio from powering up and show a 2x red error as well.</p> <p>Test red and yellow wires for DC voltage at radio using a multimeter. Contact support if no voltage on red or yellow.</p>
The steering wheel controls are not working, the Maestro RR does not blink when they are pressed.	<p>Ensure the 20 or 28-pin connector is plugged to the vehicle and to the T01 T-harness, as shown in step 3 (this is where the RR gets the steering wheel signal from the vehicle).</p>
(Prius only) After the car is turned off, the radio stays on. The car stays in accessory mode and will not turn off.	<p>Locate the white 12-pin connector of the T01 harness, it is connected to the vehicle harness.</p> <p>Then, cut and isolate the red wire located at pin 11. The radio will shut off when the vehicle is turned off.</p>

MAESTRO RR RESET PROCEDURE:

Turn the key to the OFF position, then disconnect all connectors from the module.

Press and hold the module's programming button and connect all the connectors back to the module. Wait, the module's LED will flash RED rapidly (this may take up to 10 seconds).

Release the programming button. Wait, the LED will turn solid GREEN for 2 seconds to show the reset was successful.

TECHNICAL ASSISTANCE

Phone: 1-866-427-2999

Email: maestro.support@idatalink.com

IMPORTANT: To ensure proper operation, the aftermarket radio needs to have the latest firmware from the manufacturer. Please visit the radio manufacturer's website and look for any updates pertaining to your radio.

RETAINS STEERING WHEEL CONTROLS, FACTORY AMPLIFIER, AND MORE!



PRODUCTS REQUIRED

iDatalink Maestro RR or RR2 Radio Replacement Interface
iDatalink Maestro HRR-T01 Installation Harness

PROGRAMMED FIRMWARE

ADS-RR(SR)-TOY01-DS

ADDITIONAL RESOURCES

[Maestro RR2 Programmable Outputs Guide](#)

OPTIONAL ACCESSORIES

K40[™]
ELECTRONICS
ESCORT

Click here for:
[Radar Installation Guides](#)

HEAD UNIT ADAPTER:
ACC-HU-PI01, SON1, KEN1, KEN2, ALP1

WELCOME

Congratulations on the purchase of your iDatalink Maestro RR Radio replacement solution. You are now a few simple steps away from enjoying your new car radio with enhanced features.

Before starting your installation, please ensure that your iDatalink Maestro module is programmed with the correct firmware for your vehicle and that you carefully review the install guide.

Please note that Maestro RR will only retain functionalities that were originally available in the vehicle.

TABLE OF CONTENTS

Installation Instructions	3
Wiring Diagram	4
Radio Wire Reference Chart	5
Module Diagnostics	6
Troubleshooting Table	7

NEED HELP?

 1 866 427-2999

 maestro.support@idatalink.com

INSTALLATION INSTRUCTIONS P1/1

STEP 1

Remove the factory radio

If using head unit adapter (sold separately), connect HRR-T01 harness to adapter and skip to step 2.

- Unbox the aftermarket radio and locate its main harness.
- Cut and remove the black 20 pin connector from the HRR-T01 T-harness and connect the wires, shown in the wiring diagram, from aftermarket radio main harness to the HRR-T01 T-harness and match the wire functions.

Note: only connect purple/white wire to radio reverse input or module damage will occur.

STEP 2

- Identify if your vehicle has a 20 or 28 pin secondary connector.
- Assemble T01 T-harness as shown on wiring diagram.
- Connect the factory harness to the HRR-T01 harness.

STEP 3

- Connect HRR-T01 3-pin black connector to black connector of OBDII extension harness.
- Plug the OBDII connector into the OBDII of the vehicle.

STEP 4

- Plug the harnesses into the aftermarket radio.
- Plug the Data cable to the data port of the aftermarket radio.
- Insert the Audio cable into the iDatalink 3.5 mm audio jack of the aftermarket radio (if there is no iDatalink audio input, connect to AUX).

Note: On Pioneer radio, ensure that there is nothing plugged into the W/R port.

STEP 5

- Connect all the harnesses to the Maestro RR module then test your installation.

WIRING DIAGRAM *without an Amplifier*

STEP 1

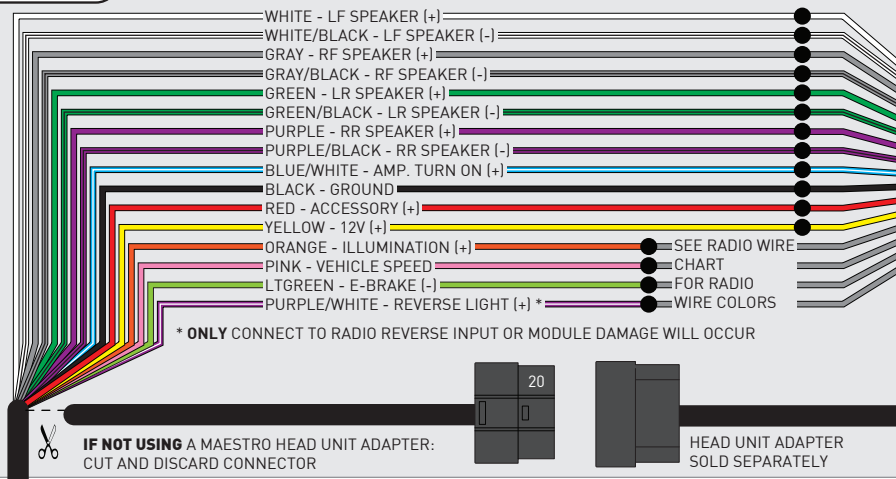

STEP 4

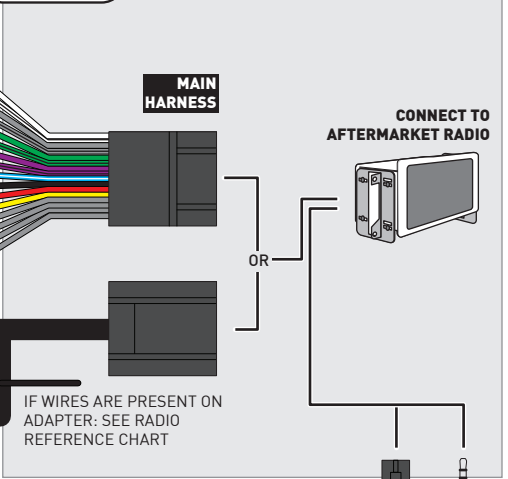

STEP 2

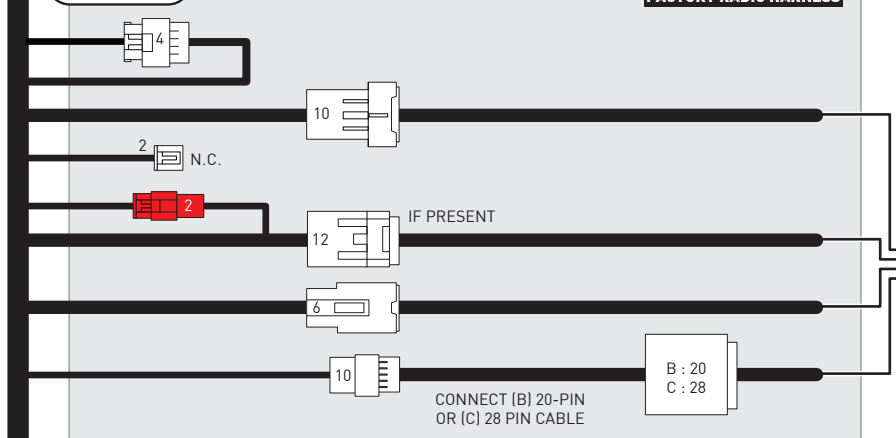

STEP 3

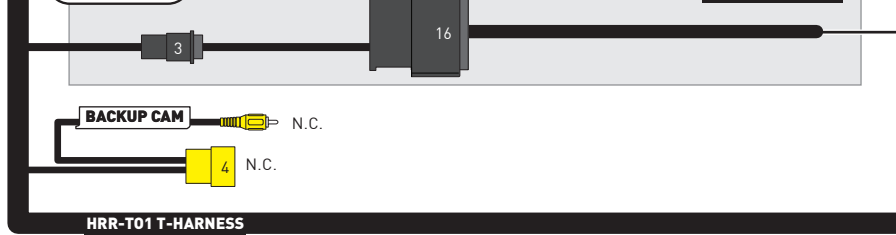

STEP 5

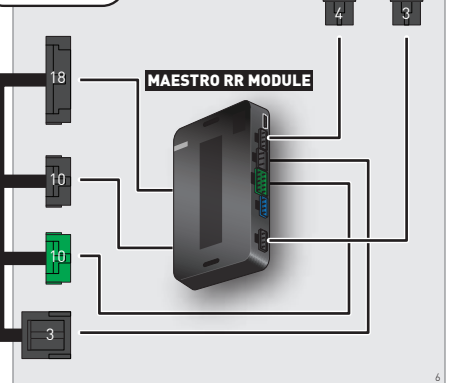

NOT REQUIRED

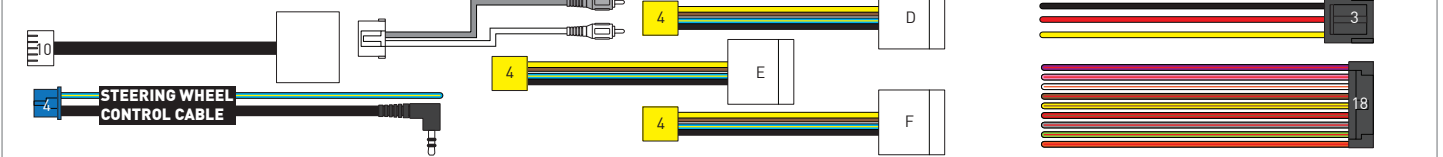

RADIO WIRE REFERENCE CHART

T01 T-harness Wire Description	Polarity	Wire Color on Maestro T-Harness	Wire Color on Alpine cable	Wire Color on Kenwood/JVC cable	Wire Color on Pioneer cable	Wire Color on Sony cable
Illumination	(+)	Orange	N/A	Orange/White	Orange/White	Orange
Reverse Light*	(+)	Purple/White	Orange/White	Purple/White	Purple/White	Purple/White
E-Brake	(-)	Lt Green	Yellow/Blue	Lt Green	Lt Green	Lt Green
VSS (vehicle speed sensor)	(DATA)	Pink	Green/White	Pink	Pink	N/A

Head unit adapter wiring (optional accessory, sold separately)

ACC-HU-ALP1 Wire Description	Polarity	Wire Color on Adapter	Alpine Radio
VSS (vehicle speed sensor)	(DATA)	Green/White	Green/White

ACC-HU-KEN1 Wire Description	Polarity	Wire Color on Adapter	Kenwood Radio
CAM	(+)	Green/Red	Refer to camera/radio manual
CAM	(-)	Green/White	Refer to camera/radio manual
Steering Wheel Controls	(DATA)	Blue/Yellow	n/a

ACC-HU-KEN2 Wire Description	Polarity	Wire Color on Adapter	Kenwood Radio
E-Brake	(-)	LtGreen	LtGreen
Reverse Light*	(+)	Purple/White	Purple/White
Steering Wheel Controls	(DATA)	Blue/Yellow	n/a

* Reverse light wire: Only connect to radio or module damage will occur.

MODULE DIAGNOSTICS



LED 1 Module/Firmware status	LED 2 (RR2) Bluetooth activity	LED STATUS	DIAGNOSTIC
or		RED or GREEN flashing	LED flashes 1 or more times, either red or green, when a steering wheel button is pressed : normal operation.
		1 RED flash	Module has no firmware. Flash module using Weblink Desktop and log in. Do <u>NOT</u> use DEMO MODE.
		2 RED flashes	Problem detected. Consult troubleshooting table.
		1 GREEN flash	After radio boots up : Normal operation.
		3 GREEN flashes	Bluetooth is activated. Turns off after one minute: Normal operation.
		OFF	Normal operation (inactive).

VIDEO HELP		Installation, product information, vehicle specific videos.
VERIFY FLASH		Last flash information, steering control configuration, vehicle information.
WEBLINK		Software to program module.

TROUBLESHOOTING TABLE

PROBLEM	SOLUTION
Gauges do not work, radio shows OBD2 Error 1 or Error 2.	<p>Ensure OBDII connector is securely attached to the OBDII connector of the vehicle.</p> <p>If you hardwired connections at the OBDII, check connections at the OBDII connector. Make sure the RED/BROWN wire is on PIN 6 and the YELLOW/BROWN wire is connected to PIN 14 of the OBDII connector. Do not use T-Taps. Soldering or military splicing methods are recommended.</p> <p>If anything else is connected to the OBD2 or CAN wires of vehicle (programmer, throttle controller, insurance tracker, etc.) try unplugging it to see if gauges work. If gauges work without it installed, call tech support for options.</p> <p>Reset the RR.</p>
The light on the Maestro is blinking RED TWICE and the radio IS turning on.	<p>Ensure the 4-pin data cable is connected between the radio and the RR, and that it is plugged into the black port on the Maestro RR. The red and blue ports on the RR should be empty.</p> <p>Make sure the correct radio model and serial number were entered during the flash. Verify the radio's serial number entered during the flash matches what is listed on the radio screen. This can be found in the settings of the radio, listed as Device Id, Device Number, or Serial Number.</p>
The light on the Maestro is blinking RED TWICE but the radio is NOT turning on.	<p>If installing a modular radio and it is not turning on, ensure the screen is secured and any trim pieces on the radio have been installed fully. Not installing these fully will prevent radio from powering up and show a 2x red error as well.</p> <p>Test red and yellow wires for DC voltage at radio using a multimeter. Contact support if no voltage on red or yellow.</p>
The steering wheel controls are not working, the Maestro RR does not blink when they are pressed.	<p>Ensure the 20 or 28-pin connector is plugged to the vehicle and to the T01 T-harness, as shown in step 3 (this is where the RR gets the steering wheel signal from the vehicle).</p>
(Prius only) After the car is turned off, the radio stays on. The car stays in accessory mode and will not turn off.	<p>Locate the white 12-pin connector of the T01 harness, it is connected to the vehicle harness.</p> <p>Then, cut and isolate the red wire located at pin 11. The radio will shut off when the vehicle is turned off.</p>

MAESTRO RR RESET PROCEDURE:

Turn the key to the OFF position, then disconnect all connectors from the module.

Press and hold the module's programming button and connect all the connectors back to the module. Wait, the module's LED will flash RED rapidly (this may take up to 10 seconds).

Release the programming button. Wait, the LED will turn solid GREEN for 2 seconds to show the reset was successful.

TECHNICAL ASSISTANCE

Phone: 1-866-427-2999

Email: maestro.support@idatalink.com

IMPORTANT: To ensure proper operation, the aftermarket radio needs to have the latest firmware from the manufacturer. Please visit the radio manufacturer's website and look for any updates pertaining to your radio.

2013

TOYOTA HIGHLANDER
WITHOUT JBL

RETAINS STEERING WHEEL CONTROLS, FACTORY AMPLIFIER, AND MORE!



PRODUCTS REQUIRED

iDatalink Maestro RR or RR2 Radio Replacement Interface
iDatalink Maestro HRR-T01 Installation Harness

PROGRAMMED FIRMWARE

ADS-RR(SR)-TOY01-DS

ADDITIONAL RESOURCES

[Maestro RR2 Programmable Outputs Guide](#)

OPTIONAL ACCESSORIES

K40[™]
ELECTRONICS
ESCORT

Click here for:
[Radar Installation Guides](#)

HEAD UNIT ADAPTER:
ACC-HU-PI01, SON1, KEN1, KEN2, ALP1

WELCOME

Congratulations on the purchase of your iDatalink Maestro RR Radio replacement solution. You are now a few simple steps away from enjoying your new car radio with enhanced features.

Before starting your installation, please ensure that your iDatalink Maestro module is programmed with the correct firmware for your vehicle and that you carefully review the install guide.

Please note that Maestro RR will only retain functionalities that were originally available in the vehicle.

TABLE OF CONTENTS

Installation Instructions	3
Wiring Diagram	4
Radio Wire Reference Chart	5
Module Diagnostics	6
Troubleshooting Table	7

NEED HELP?

 1 866 427-2999

 maestro.support@idatalink.com

INSTALLATION INSTRUCTIONS P1/1

STEP 1

Remove the factory radio

If using head unit adapter (sold separately), connect HRR-T01 harness to adapter and skip to step 2.

- Unbox the aftermarket radio and locate its main harness.
- Cut and remove the black 20 pin connector from the HRR-T01 T-harness and connect the wires, shown in the wiring diagram, from aftermarket radio main harness to the HRR-T01 T-harness and match the wire functions.

Note: only connect purple/white wire to radio reverse input or module damage will occur.

STEP 2

- If the vehicle is equipped with an OEM backup camera, connect the HRR-T01 harness to appropriate HRR adapter cable (D, E or F) then connect to the backup camera harness.

STEP 3

- Identify if your vehicle has a 20 or 28 pin secondary connector.
- Assemble T01 T-harness as shown on wiring diagram.
- Connect the factory harness to the HRR-T01 harness.

STEP 4

- Connect HRR-T01 3-pin black connector to black connector of OBDII extension harness.
- Plug the OBDII connector into the OBDII of the vehicle.

STEP 5

- Plug the harnesses into the aftermarket radio.
- Connect the backup camera RCA cable into the aftermarket radio (if equipped).
- Plug the Data cable to the data port of the aftermarket radio.
- Insert the Audio cable into the iDatalink 3.5 mm audio jack of the aftermarket radio (if there is no iDatalink audio input, connect to AUX).

Note: On Pioneer radio, ensure that there is nothing plugged into the W/R port.

STEP 6

- Connect all the harnesses to the Maestro RR module then test your installation.

WIRING DIAGRAM *without an Amplifier*

STEP 1

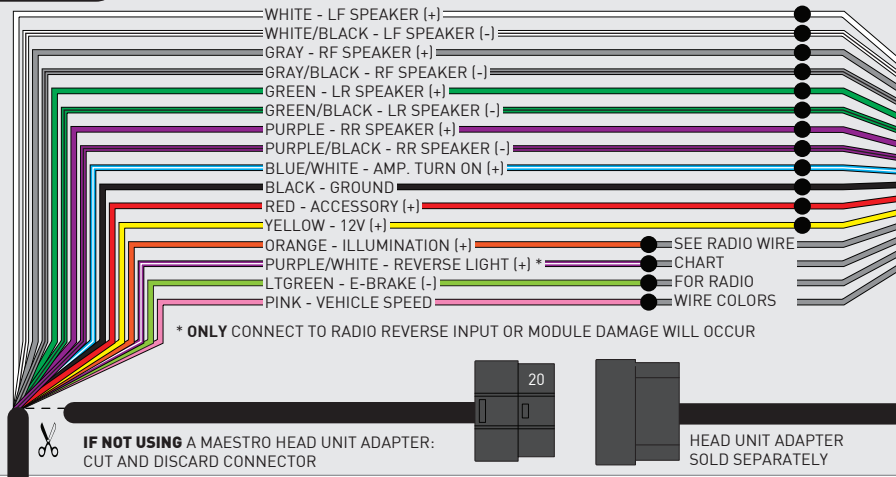

STEP 5

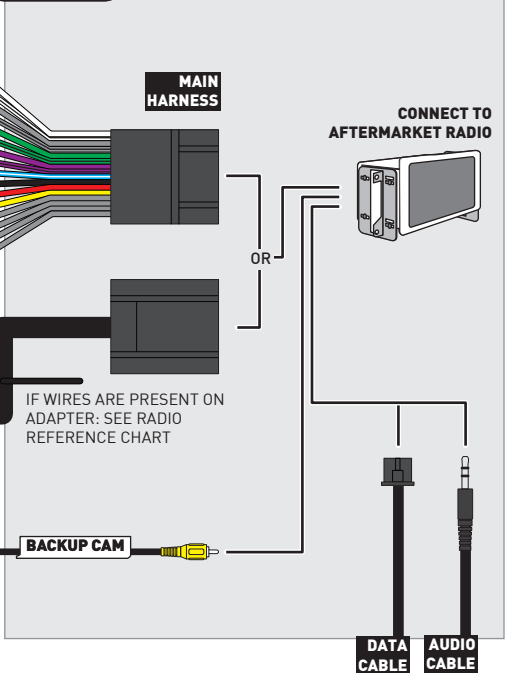

STEP 2

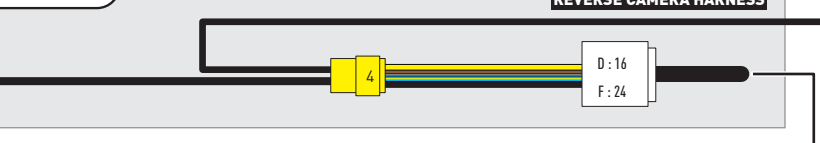

STEP 3

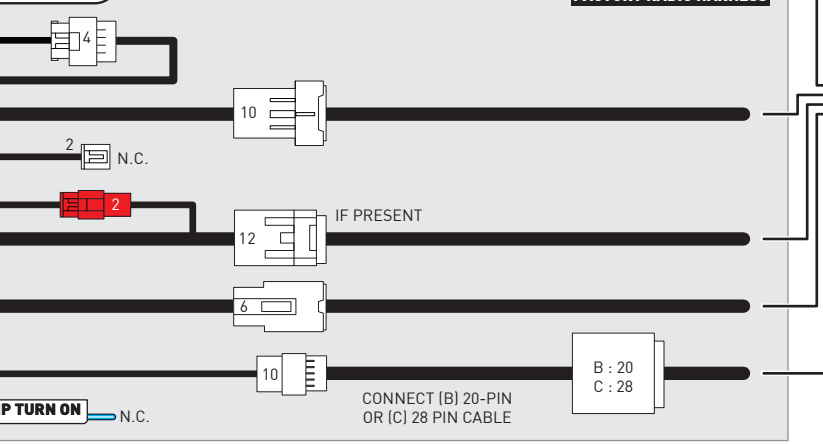

STEP 4



STEP 6

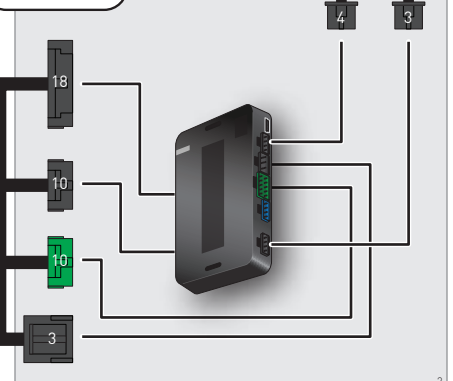

NOT REQUIRED

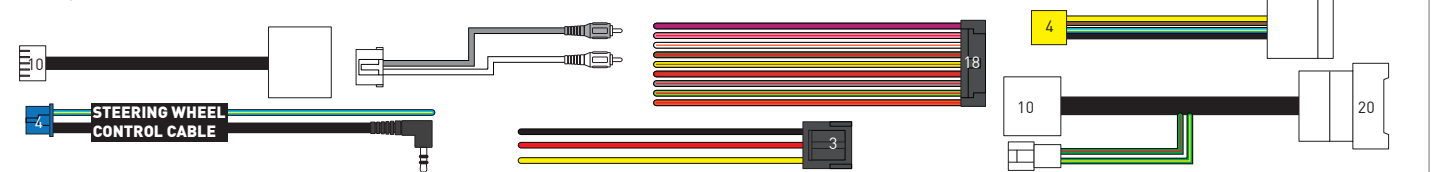

RADIO WIRE REFERENCE CHART

T01 T-harness Wire Description	Polarity	Wire Color on Maestro T-Harness	Wire Color on Alpine cable	Wire Color on Kenwood/JVC cable	Wire Color on Pioneer cable	Wire Color on Sony cable
Illumination	(+)	Orange	N/A	Orange/White	Orange/White	Orange
Reverse Light*	(+)	Purple/White	Orange/White	Purple/White	Purple/White	Purple/White
E-Brake	(-)	Lt Green	Yellow/Blue	Lt Green	Lt Green	Lt Green
VSS (vehicle speed sensor)	(DATA)	Pink	Green/White	Pink	Pink	N/A

Head unit adapter wiring (optional accessory, sold separately)

ACC-HU-ALP1 Wire Description	Polarity	Wire Color on Adapter	Alpine Radio
VSS (vehicle speed sensor)	(DATA)	Green/White	Green/White

ACC-HU-KEN1 Wire Description	Polarity	Wire Color on Adapter	Kenwood Radio
CAM	(+)	Green/Red	Refer to camera/radio manual
CAM	(-)	Green/White	Refer to camera/radio manual
Steering Wheel Controls	(DATA)	Blue/Yellow	n/a

ACC-HU-KEN2 Wire Description	Polarity	Wire Color on Adapter	Kenwood Radio
E-Brake	(-)	LtGreen	LtGreen
Reverse Light*	(+)	Purple/White	Purple/White
Steering Wheel Controls	(DATA)	Blue/Yellow	n/a

* Reverse light wire: Only connect to radio or module damage will occur.

MODULE DIAGNOSTICS



LED 1 Module/Firmware status	LED 2 (RR2) Bluetooth activity	LED STATUS	DIAGNOSTIC
or		RED or GREEN flashing	LED flashes 1 or more times, either red or green, when a steering wheel button is pressed : normal operation.
		1 RED flash	Module has no firmware. Flash module using Weblink Desktop and log in. Do <u>NOT</u> use DEMO MODE.
		2 RED flashes	Problem detected. Consult troubleshooting table.
		1 GREEN flash	After radio boots up : Normal operation.
		3 GREEN flashes	Bluetooth is activated. Turns off after one minute: Normal operation.
		OFF	Normal operation (inactive).

VIDEO HELP		Installation, product information, vehicle specific videos.
VERIFY FLASH		Last flash information, steering control configuration, vehicle information.
WEBLINK		Software to program module.

TROUBLESHOOTING TABLE

PROBLEM	SOLUTION
Gauges do not work, radio shows OBD2 Error 1 or Error 2.	<p>Ensure OBDII connector is securely attached to the OBDII connector of the vehicle.</p> <p>If you hardwired connections at the OBDII, check connections at the OBDII connector. Make sure the RED/BROWN wire is on PIN 6 and the YELLOW/BROWN wire is connected to PIN 14 of the OBDII connector. Do not use T-Taps. Soldering or military splicing methods are recommended.</p> <p>If anything else is connected to the OBD2 or CAN wires of vehicle (programmer, throttle controller, insurance tracker, etc.) try unplugging it to see if gauges work. If gauges work without it installed, call tech support for options.</p> <p>Reset the RR.</p>
The light on the Maestro is blinking RED TWICE and the radio IS turning on.	<p>Ensure the 4-pin data cable is connected between the radio and the RR, and that it is plugged into the black port on the Maestro RR. The red and blue ports on the RR should be empty.</p> <p>Make sure the correct radio model and serial number were entered during the flash. Verify the radio's serial number entered during the flash matches what is listed on the radio screen. This can be found in the settings of the radio, listed as Device Id, Device Number, or Serial Number.</p>
The light on the Maestro is blinking RED TWICE but the radio is NOT turning on.	<p>If installing a modular radio and it is not turning on, ensure the screen is secured and any trim pieces on the radio have been installed fully. Not installing these fully will prevent radio from powering up and show a 2x red error as well.</p> <p>Test red and yellow wires for DC voltage at radio using a multimeter. Contact support if no voltage on red or yellow.</p>
The steering wheel controls are not working, the Maestro RR does not blink when they are pressed.	<p>Ensure the 20 or 28-pin connector is plugged to the vehicle and to the T01 T-harness, as shown in step 3 (this is where the RR gets the steering wheel signal from the vehicle).</p>
(Prius only) After the car is turned off, the radio stays on. The car stays in accessory mode and will not turn off.	<p>Locate the white 12-pin connector of the T01 harness, it is connected to the vehicle harness.</p> <p>Then, cut and isolate the red wire located at pin 11. The radio will shut off when the vehicle is turned off.</p>

MAESTRO RR RESET PROCEDURE:

Turn the key to the OFF position, then disconnect all connectors from the module.

Press and hold the module's programming button and connect all the connectors back to the module. Wait, the module's LED will flash RED rapidly (this may take up to 10 seconds).

Release the programming button. Wait, the LED will turn solid GREEN for 2 seconds to show the reset was successful.

TECHNICAL ASSISTANCE

Phone: 1-866-427-2999

Email: maestro.support@idatalink.com

IMPORTANT: To ensure proper operation, the aftermarket radio needs to have the latest firmware from the manufacturer. Please visit the radio manufacturer's website and look for any updates pertaining to your radio.

RETAINS STEERING WHEEL CONTROLS, FACTORY AMPLIFIER, AND MORE!



PRODUCTS REQUIRED

iDataLink Maestro RR or RR2 Radio Replacement Interface
iDataLink Maestro HRR-T01 Installation Harness

PROGRAMMED FIRMWARE

ADS-RR(SR)-TOY01-DS

ADDITIONAL RESOURCES

[Maestro RR2 Programmable Outputs Guide](#)

OPTIONAL ACCESSORIES

K40[™]
ELECTRONICS
ESCORT

Click here for:
[Radar Installation Guides](#)

HEAD UNIT ADAPTER:
ACC-HU-PI01, SON1, KEN1, KEN2, ALP1

WELCOME

Congratulations on the purchase of your iDatalink Maestro RR Radio replacement solution. You are now a few simple steps away from enjoying your new car radio with enhanced features.

Before starting your installation, please ensure that your iDatalink Maestro module is programmed with the correct firmware for your vehicle and that you carefully review the install guide.

Please note that Maestro RR will only retain functionalities that were originally available in the vehicle.

TABLE OF CONTENTS

Installation Instructions	3
Wiring Diagram	4
Radio Wire Reference Chart	5
Module Diagnostics	6
Troubleshooting Table	7

NEED HELP?

 1 866 427-2999

 maestro.support@idatalink.com

INSTALLATION INSTRUCTIONS P1/1

STEP 1

Remove the factory radio

If using head unit adapter (sold separately), connect HRR-T01 harness to adapter and skip to step 2.

- Unbox the aftermarket radio and locate its main harness.
- Cut and remove the black 20 pin connector from the HRR-T01 T-harness and connect the wires, shown in the wiring diagram, from aftermarket radio main harness to the HRR-T01 T-harness and match the wire functions.

Note: only connect purple/white wire to radio reverse input or module damage will occur.

STEP 2

- Identify if your vehicle has a 20 or 28 pin secondary connector.
- Assemble T01 T-harness as shown on wiring diagram.
- Connect the factory harness to the HRR-T01 harness.

STEP 3

- Connect HRR-T01 3-pin black connector to black connector of OBDII extension harness.
- Plug the OBDII connector into the OBDII of the vehicle.

STEP 4

- Plug the harnesses into the aftermarket radio.
- Plug the Data cable to the data port of the aftermarket radio.
- Insert the Audio cable into the iDatalink 3.5 mm audio jack of the aftermarket radio (if there is no iDatalink audio input, connect to AUX).

Note: On Pioneer radio, ensure that there is nothing plugged into the W/R port.

STEP 5

- Connect all the harnesses to the Maestro RR module then test your installation.

WIRING DIAGRAM *without an Amplifier*

STEP 1

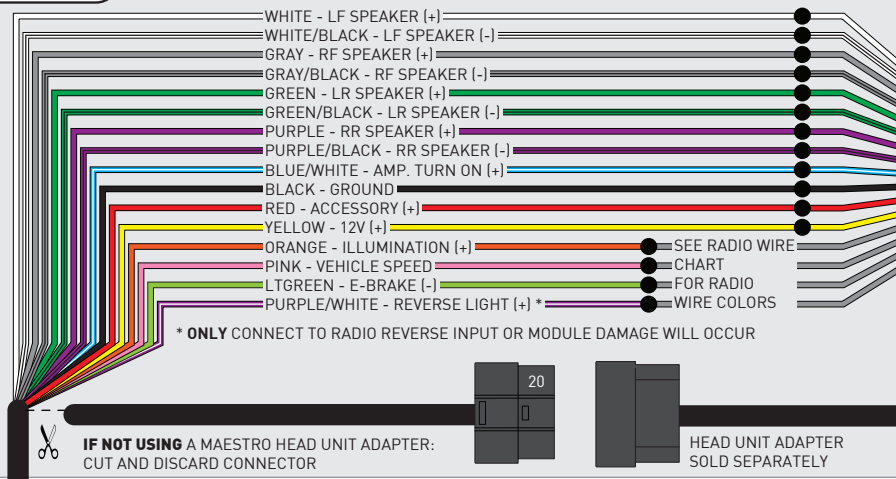

STEP 4

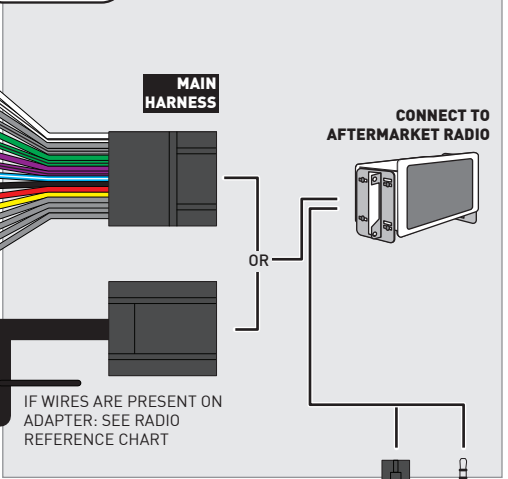

STEP 2

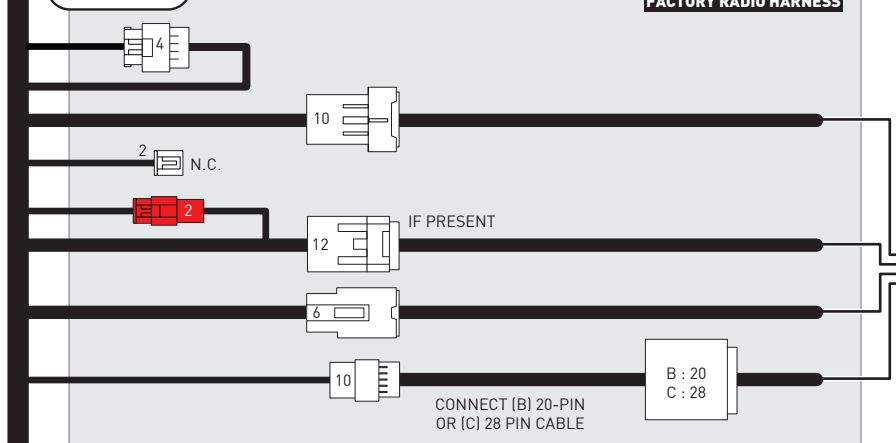

STEP 3



STEP 5

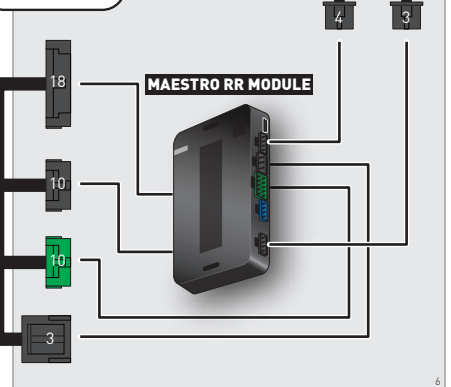

NOT REQUIRED

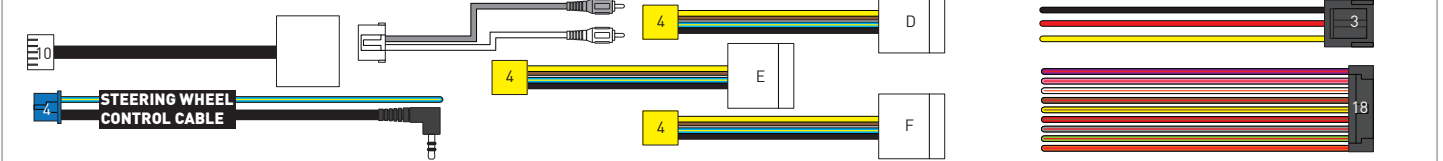

RADIO WIRE REFERENCE CHART

T01 T-harness Wire Description	Polarity	Wire Color on Maestro T-Harness	Wire Color on Alpine cable	Wire Color on Kenwood/JVC cable	Wire Color on Pioneer cable	Wire Color on Sony cable
Illumination	(+)	Orange	N/A	Orange/White	Orange/White	Orange
Reverse Light*	(+)	Purple/White	Orange/White	Purple/White	Purple/White	Purple/White
E-Brake	(-)	Lt Green	Yellow/Blue	Lt Green	Lt Green	Lt Green
VSS (vehicle speed sensor)	(DATA)	Pink	Green/White	Pink	Pink	N/A

Head unit adapter wiring (optional accessory, sold separately)

ACC-HU-ALP1 Wire Description	Polarity	Wire Color on Adapter	Alpine Radio
VSS (vehicle speed sensor)	(DATA)	Green/White	Green/White

ACC-HU-KEN1 Wire Description	Polarity	Wire Color on Adapter	Kenwood Radio
CAM	(+)	Green/Red	Refer to camera/radio manual
CAM	(-)	Green/White	Refer to camera/radio manual
Steering Wheel Controls	(DATA)	Blue/Yellow	n/a

ACC-HU-KEN2 Wire Description	Polarity	Wire Color on Adapter	Kenwood Radio
E-Brake	(-)	LtGreen	LtGreen
Reverse Light*	(+)	Purple/White	Purple/White
Steering Wheel Controls	(DATA)	Blue/Yellow	n/a

* Reverse light wire: Only connect to radio or module damage will occur.

MODULE DIAGNOSTICS



LED 1 Module/Firmware status	LED 2 (RR2) Bluetooth activity	LED STATUS	DIAGNOSTIC
or		RED or GREEN flashing	LED flashes 1 or more times, either red or green, when a steering wheel button is pressed : normal operation.
		1 RED flash	Module has no firmware. Flash module using Weblink Desktop and log in. Do <u>NOT</u> use DEMO MODE.
		2 RED flashes	Problem detected. Consult troubleshooting table.
		1 GREEN flash	After radio boots up : Normal operation.
		3 GREEN flashes	Bluetooth is activated. Turns off after one minute: Normal operation.
		OFF	Normal operation (inactive).

VIDEO HELP		Installation, product information, vehicle specific videos.
VERIFY FLASH		Last flash information, steering control configuration, vehicle information.
WEBLINK		Software to program module.

TROUBLESHOOTING TABLE

PROBLEM	SOLUTION
Gauges do not work, radio shows OBD2 Error 1 or Error 2.	<p>Ensure OBDII connector is securely attached to the OBDII connector of the vehicle.</p> <p>If you hardwired connections at the OBDII, check connections at the OBDII connector. Make sure the RED/BROWN wire is on PIN 6 and the YELLOW/BROWN wire is connected to PIN 14 of the OBDII connector. Do not use T-Taps. Soldering or military splicing methods are recommended.</p> <p>If anything else is connected to the OBD2 or CAN wires of vehicle (programmer, throttle controller, insurance tracker, etc.) try unplugging it to see if gauges work. If gauges work without it installed, call tech support for options.</p> <p>Reset the RR.</p>
The light on the Maestro is blinking RED TWICE and the radio IS turning on.	<p>Ensure the 4-pin data cable is connected between the radio and the RR, and that it is plugged into the black port on the Maestro RR. The red and blue ports on the RR should be empty.</p> <p>Make sure the correct radio model and serial number were entered during the flash. Verify the radio's serial number entered during the flash matches what is listed on the radio screen. This can be found in the settings of the radio, listed as Device Id, Device Number, or Serial Number.</p>
The light on the Maestro is blinking RED TWICE but the radio is NOT turning on.	<p>If installing a modular radio and it is not turning on, ensure the screen is secured and any trim pieces on the radio have been installed fully. Not installing these fully will prevent radio from powering up and show a 2x red error as well.</p> <p>Test red and yellow wires for DC voltage at radio using a multimeter. Contact support if no voltage on red or yellow.</p>
The steering wheel controls are not working, the Maestro RR does not blink when they are pressed.	<p>Ensure the 20 or 28-pin connector is plugged to the vehicle and to the T01 T-harness, as shown in step 3 (this is where the RR gets the steering wheel signal from the vehicle).</p>
(Prius only) After the car is turned off, the radio stays on. The car stays in accessory mode and will not turn off.	<p>Locate the white 12-pin connector of the T01 harness, it is connected to the vehicle harness.</p> <p>Then, cut and isolate the red wire located at pin 11. The radio will shut off when the vehicle is turned off.</p>

MAESTRO RR RESET PROCEDURE:

Turn the key to the OFF position, then disconnect all connectors from the module.

Press and hold the module's programming button and connect all the connectors back to the module. Wait, the module's LED will flash RED rapidly (this may take up to 10 seconds).

Release the programming button. Wait, the LED will turn solid GREEN for 2 seconds to show the reset was successful.

TECHNICAL ASSISTANCE

Phone: 1-866-427-2999

Email: maestro.support@idatalink.com

IMPORTANT: To ensure proper operation, the aftermarket radio needs to have the latest firmware from the manufacturer. Please visit the radio manufacturer's website and look for any updates pertaining to your radio.

RETAINS STEERING WHEEL CONTROLS, FACTORY AMPLIFIER, AND MORE!



PRODUCTS REQUIRED

iDatalink Maestro RR or RR2 Radio Replacement Interface
iDatalink Maestro HRR-T01 Installation Harness

PROGRAMMED FIRMWARE

ADS-RR(SR)-TOY01-DS

ADDITIONAL RESOURCES

[Maestro RR2 Programmable Outputs Guide](#)

OPTIONAL ACCESSORIES

K40
ELECTRONICS
ESCORT

Click here for:
[Radar Installation Guides](#)

HEAD UNIT ADAPTER:
ACC-HU-PI01, SON1, KEN1, KEN2, ALP1

WELCOME

Congratulations on the purchase of your iDatalink Maestro RR Radio replacement solution. You are now a few simple steps away from enjoying your new car radio with enhanced features.

Before starting your installation, please ensure that your iDatalink Maestro module is programmed with the correct firmware for your vehicle and that you carefully review the install guide.

Please note that Maestro RR will only retain functionalities that were originally available in the vehicle.

TABLE OF CONTENTS

Installation Instructions	3
Wiring Diagram	4
Radio Wire Reference Chart	5
Module Diagnostics	6
Troubleshooting Table	7

NEED HELP?

 1 866 427-2999

 maestro.support@idatalink.com

INSTALLATION INSTRUCTIONS P1/1

STEP 1

Remove the factory radio

If using head unit adapter (sold separately), connect HRR-T01 harness to adapter and skip to step 2.

- Unbox the aftermarket radio and locate its main harness.
- Cut and remove the black 20 pin connector from the HRR-T01 T-harness and connect the wires, shown in the wiring diagram, from aftermarket radio main harness to the HRR-T01 T-harness and match the wire functions.

Note: only connect purple/white wire to radio reverse input or module damage will occur.

STEP 2

- If the vehicle is equipped with an OEM backup camera, connect the HRR-T01 harness to appropriate HRR adapter cable (D, E or F) then connect to the backup camera harness.

STEP 3

- Identify if your vehicle has a 20 or 28 pin secondary connector.
- Assemble T01 T-harness as shown on wiring diagram.
- Connect the factory harness to the HRR-T01 harness.

STEP 4

- Connect HRR-T01 3-pin black connector to black connector of OBDII extension harness.
- Plug the OBDII connector into the OBDII of the vehicle.

STEP 5

- Plug the harnesses into the aftermarket radio.
- Connect the backup camera RCA cable into the aftermarket radio (if equipped).
- Connect the left front and right front low level outputs RCA cables into the aftermarket radio.
- Plug the Data cable to the data port of the aftermarket radio.
- Insert the Audio cable into the iDatalink 3.5 mm audio jack of the aftermarket radio (if there is no iDatalink audio input, connect to AUX).

Note: On Pioneer radio, ensure that there is nothing plugged into the W/R port.

STEP 6

- Connect all the harnesses to the Maestro RR module then test your installation.

WIRING DIAGRAM *with an Amplifier*

STEP 1

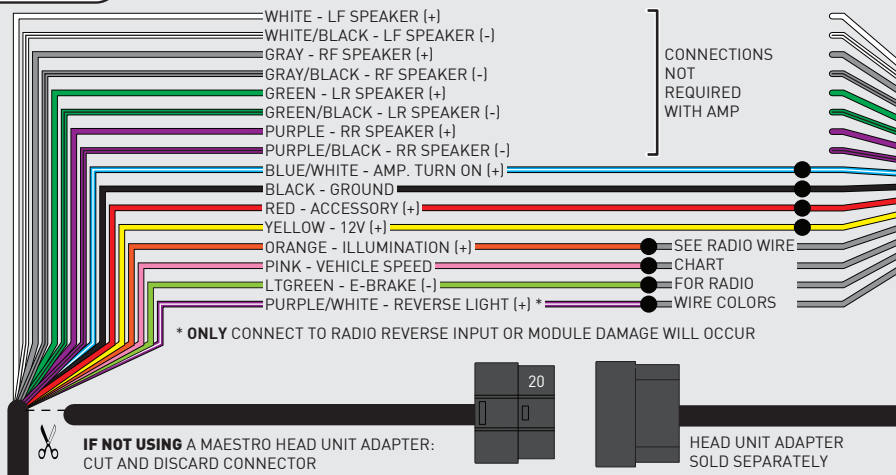

STEP 5

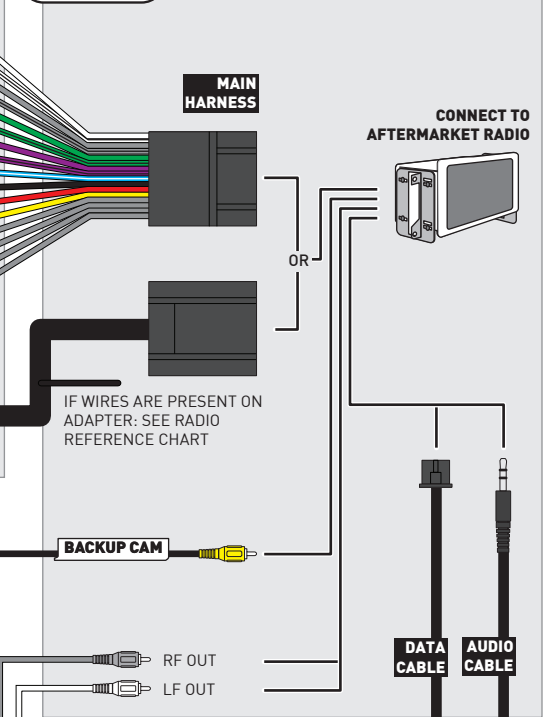

STEP 2

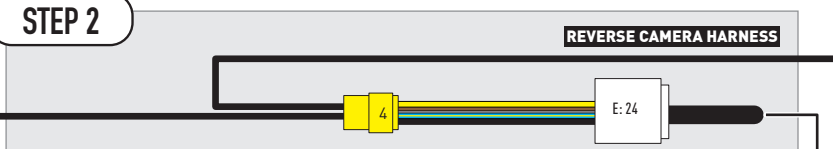

STEP 3

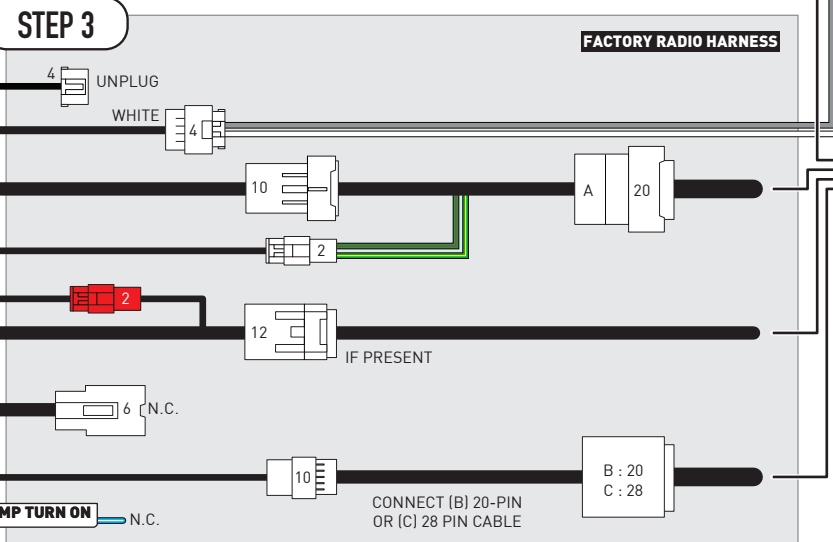

STEP 4

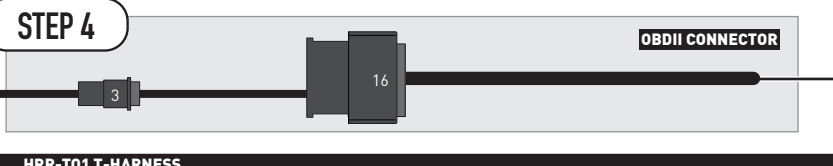

STEP 6

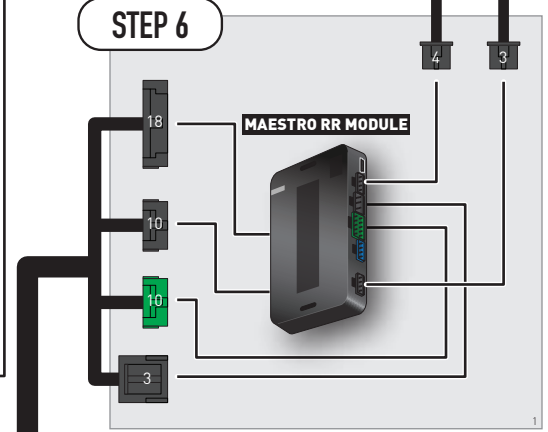

NOT REQUIRED

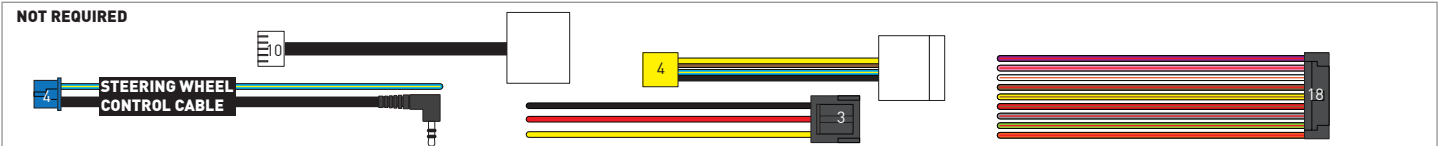

RADIO WIRE REFERENCE CHART

T01 T-harness Wire Description	Polarity	Wire Color on Maestro T-Harness	Wire Color on Alpine cable	Wire Color on Kenwood/JVC cable	Wire Color on Pioneer cable	Wire Color on Sony cable
Illumination	(+)	Orange	N/A	Orange/White	Orange/White	Orange
Reverse Light*	(+)	Purple/White	Orange/White	Purple/White	Purple/White	Purple/White
E-Brake	(-)	Lt Green	Yellow/Blue	Lt Green	Lt Green	Lt Green
VSS (vehicle speed sensor)	(DATA)	Pink	Green/White	Pink	Pink	N/A

Head unit adapter wiring (optional accessory, sold separately)

ACC-HU-ALP1 Wire Description	Polarity	Wire Color on Adapter	Alpine Radio
VSS (vehicle speed sensor)	(DATA)	Green/White	Green/White

ACC-HU-KEN1 Wire Description	Polarity	Wire Color on Adapter	Kenwood Radio
CAM	(+)	Green/Red	Refer to camera/radio manual
CAM	(-)	Green/White	Refer to camera/radio manual
Steering Wheel Controls	(DATA)	Blue/Yellow	n/a

ACC-HU-KEN2 Wire Description	Polarity	Wire Color on Adapter	Kenwood Radio
E-Brake	(-)	LtGreen	LtGreen
Reverse Light*	(+)	Purple/White	Purple/White
Steering Wheel Controls	(DATA)	Blue/Yellow	n/a

* Reverse light wire: Only connect to radio or module damage will occur.

MODULE DIAGNOSTICS



LED 1 Module/Firmware status	LED 2 (RR2) Bluetooth activity	LED STATUS	DIAGNOSTIC
or		RED or GREEN flashing	LED flashes 1 or more times, either red or green, when a steering wheel button is pressed : normal operation.
		1 RED flash	Module has no firmware. Flash module using Weblink Desktop and log in. Do <u>NOT</u> use DEMO MODE.
		2 RED flashes	Problem detected. Consult troubleshooting table.
		1 GREEN flash	After radio boots up : Normal operation.
		3 GREEN flashes	Bluetooth is activated. Turns off after one minute: Normal operation.
		OFF	Normal operation (inactive).

VIDEO HELP		Installation, product information, vehicle specific videos.
VERIFY FLASH		Last flash information, steering control configuration, vehicle information.
WEBLINK		Software to program module.

TROUBLESHOOTING TABLE

PROBLEM	SOLUTION
Gauges do not work, radio shows OBD2 Error 1 or Error 2.	<p>Ensure OBDII connector is securely attached to the OBDII connector of the vehicle.</p> <p>If you hardwired connections at the OBDII, check connections at the OBDII connector. Make sure the RED/BROWN wire is on PIN 6 and the YELLOW/BROWN wire is connected to PIN 14 of the OBDII connector. Do not use T-Taps. Soldering or military splicing methods are recommended.</p> <p>If anything else is connected to the OBD2 or CAN wires of vehicle (programmer, throttle controller, insurance tracker, etc.) try unplugging it to see if gauges work. If gauges work without it installed, call tech support for options.</p> <p>Reset the RR.</p>
The light on the Maestro is blinking RED TWICE and the radio IS turning on.	<p>Ensure the 4-pin data cable is connected between the radio and the RR, and that it is plugged into the black port on the Maestro RR. The red and blue ports on the RR should be empty.</p> <p>Make sure the correct radio model and serial number were entered during the flash. Verify the radio's serial number entered during the flash matches what is listed on the radio screen. This can be found in the settings of the radio, listed as Device Id, Device Number, or Serial Number.</p>
The light on the Maestro is blinking RED TWICE but the radio is NOT turning on.	<p>If installing a modular radio and it is not turning on, ensure the screen is secured and any trim pieces on the radio have been installed fully. Not installing these fully will prevent radio from powering up and show a 2x red error as well.</p> <p>Test red and yellow wires for DC voltage at radio using a multimeter. Contact support if no voltage on red or yellow.</p>
The steering wheel controls are not working, the Maestro RR does not blink when they are pressed.	<p>Ensure the 20 or 28-pin connector is plugged to the vehicle and to the T01 T-harness, as shown in step 3 (this is where the RR gets the steering wheel signal from the vehicle).</p>
(Prius only) After the car is turned off, the radio stays on. The car stays in accessory mode and will not turn off.	<p>Locate the white 12-pin connector of the T01 harness, it is connected to the vehicle harness.</p> <p>Then, cut and isolate the red wire located at pin 11. The radio will shut off when the vehicle is turned off.</p>

MAESTRO RR RESET PROCEDURE:

Turn the key to the OFF position, then disconnect all connectors from the module.

Press and hold the module's programming button and connect all the connectors back to the module. Wait, the module's LED will flash RED rapidly (this may take up to 10 seconds).

Release the programming button. Wait, the LED will turn solid GREEN for 2 seconds to show the reset was successful.

TECHNICAL ASSISTANCE

Phone: 1-866-427-2999

Email: maestro.support@idatalink.com

IMPORTANT: To ensure proper operation, the aftermarket radio needs to have the latest firmware from the manufacturer. Please visit the radio manufacturer's website and look for any updates pertaining to your radio.

RETAINS STEERING WHEEL CONTROLS, FACTORY AMPLIFIER, AND MORE!



PRODUCTS REQUIRED

iDatalink Maestro RR or RR2 Radio Replacement Interface
iDatalink Maestro HRR-T01 Installation Harness

PROGRAMMED FIRMWARE

ADS-RR(SR)-TOY01-DS

ADDITIONAL RESOURCES

[Maestro RR2 Programmable Outputs Guide](#)

OPTIONAL ACCESSORIES



Click here for:
[Radar Installation Guides](#)

HEAD UNIT ADAPTER:
ACC-HU-PI01, SON1, KEN1, KEN2, ALP1

WELCOME

Congratulations on the purchase of your iDatalink Maestro RR Radio replacement solution. You are now a few simple steps away from enjoying your new car radio with enhanced features.

Before starting your installation, please ensure that your iDatalink Maestro module is programmed with the correct firmware for your vehicle and that you carefully review the install guide.

Please note that Maestro RR will only retain functionalities that were originally available in the vehicle.

TABLE OF CONTENTS

Installation Instructions	3
Wiring Diagram	4
Radio Wire Reference Chart	5
Module Diagnostics	6
Troubleshooting Table	7

NEED HELP?

 1 866 427-2999

 maestro.support@idatalink.com

INSTALLATION INSTRUCTIONS P1/1

STEP 1

Remove the factory radio

If using head unit adapter (sold separately), connect HRR-T01 harness to adapter and skip to step 2.

- Unbox the aftermarket radio and locate its main harness.
- Cut and remove the black 20 pin connector from the HRR-T01 T-harness and connect the wires, shown in the wiring diagram, from aftermarket radio main harness to the HRR-T01 T-harness and match the wire functions.

Note: only connect purple/white wire to radio reverse input or module damage will occur.

STEP 2

- If the vehicle is equipped with an OEM backup camera, connect the HRR-T01 harness to appropriate HRR adapter cable (D, E or F) then connect to the backup camera harness.

STEP 3

- Identify if your vehicle has a 20 or 28 pin secondary connector.
- Assemble T01 T-harness as shown on wiring diagram.
- Connect the factory harness to the HRR-T01 harness.

STEP 4

- Connect HRR-T01 3-pin black connector to black connector of OBDII extension harness.
- Plug the OBDII connector into the OBDII of the vehicle.

STEP 5

- Plug the harnesses into the aftermarket radio.
- Connect the backup camera RCA cable into the aftermarket radio (if equipped).
- Plug the Data cable to the data port of the aftermarket radio.
- Insert the Audio cable into the iDatalink 3.5 mm audio jack of the aftermarket radio (if there is no iDatalink audio input, connect to AUX).

Note: On Pioneer radio, ensure that there is nothing plugged into the W/R port.

STEP 6

- Connect all the harnesses to the Maestro RR module then test your installation.

WIRING DIAGRAM *without an Amplifier*

STEP 1

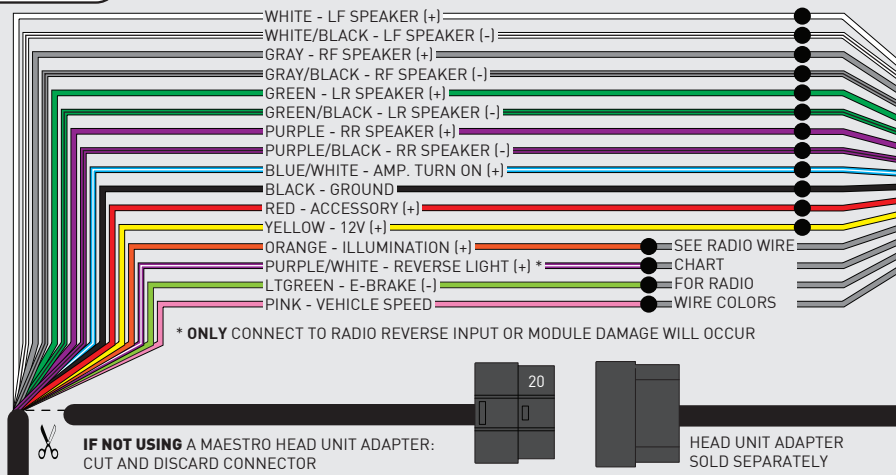

STEP 5

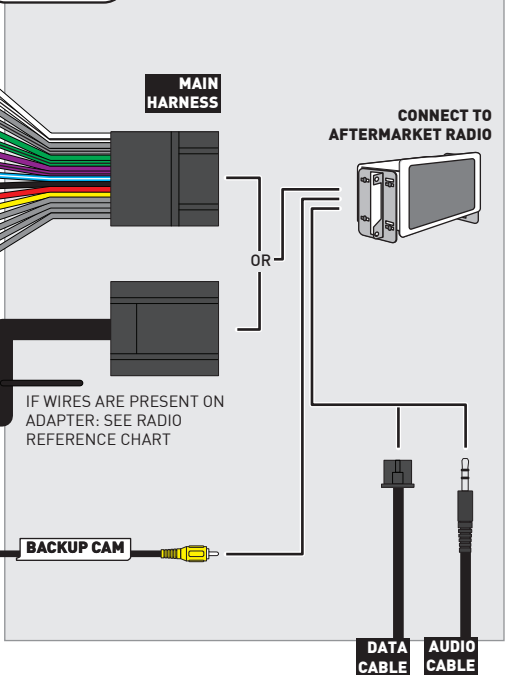

STEP 2

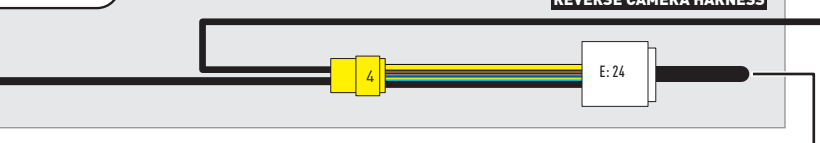

STEP 3

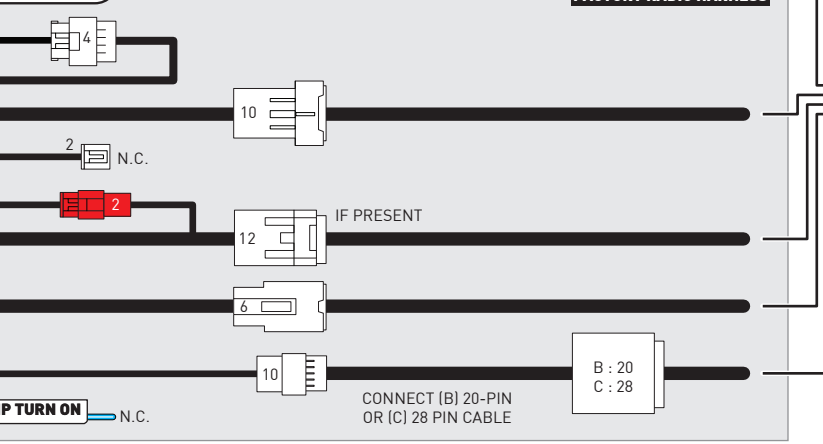

STEP 4



STEP 6

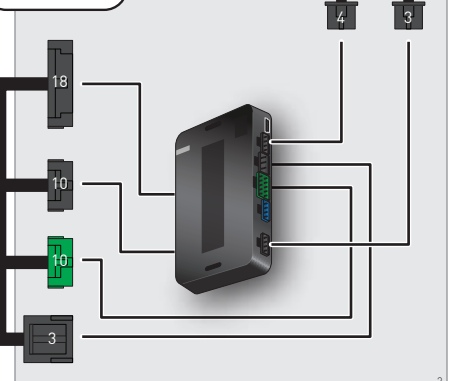

NOT REQUIRED

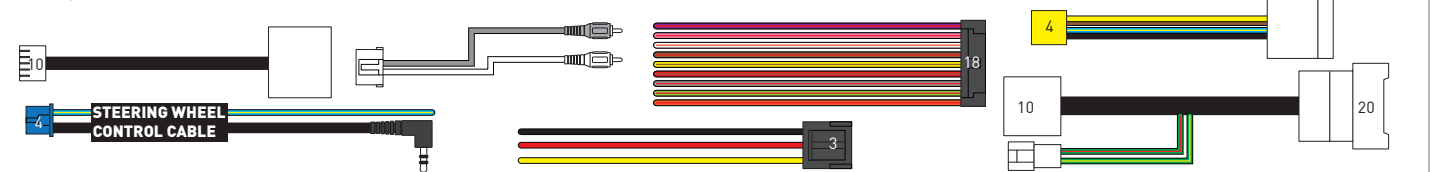

RADIO WIRE REFERENCE CHART

T01 T-harness Wire Description	Polarity	Wire Color on Maestro T-Harness	Wire Color on Alpine cable	Wire Color on Kenwood/JVC cable	Wire Color on Pioneer cable	Wire Color on Sony cable
Illumination	(+)	Orange	N/A	Orange/White	Orange/White	Orange
Reverse Light*	(+)	Purple/White	Orange/White	Purple/White	Purple/White	Purple/White
E-Brake	(-)	Lt Green	Yellow/Blue	Lt Green	Lt Green	Lt Green
VSS (vehicle speed sensor)	(DATA)	Pink	Green/White	Pink	Pink	N/A

Head unit adapter wiring (optional accessory, sold separately)

ACC-HU-ALP1 Wire Description	Polarity	Wire Color on Adapter	Alpine Radio
VSS (vehicle speed sensor)	(DATA)	Green/White	Green/White

ACC-HU-KEN1 Wire Description	Polarity	Wire Color on Adapter	Kenwood Radio
CAM	(+)	Green/Red	Refer to camera/radio manual
CAM	(-)	Green/White	Refer to camera/radio manual
Steering Wheel Controls	(DATA)	Blue/Yellow	n/a

ACC-HU-KEN2 Wire Description	Polarity	Wire Color on Adapter	Kenwood Radio
E-Brake	(-)	LtGreen	LtGreen
Reverse Light*	(+)	Purple/White	Purple/White
Steering Wheel Controls	(DATA)	Blue/Yellow	n/a

* Reverse light wire: Only connect to radio or module damage will occur.

MODULE DIAGNOSTICS



LED 1 Module/Firmware status	LED 2 (RR2) Bluetooth activity	LED STATUS	DIAGNOSTIC
or		RED or GREEN flashing	LED flashes 1 or more times, either red or green, when a steering wheel button is pressed : normal operation.
		1 RED flash	Module has no firmware. Flash module using Weblink Desktop and log in. Do <u>NOT</u> use DEMO MODE.
		2 RED flashes	Problem detected. Consult troubleshooting table.
		1 GREEN flash	After radio boots up : Normal operation.
		3 GREEN flashes	Bluetooth is activated. Turns off after one minute: Normal operation.
		OFF	Normal operation (inactive).

VIDEO HELP		Installation, product information, vehicle specific videos.
VERIFY FLASH		Last flash information, steering control configuration, vehicle information.
WEBLINK		Software to program module.

TROUBLESHOOTING TABLE

PROBLEM	SOLUTION
Gauges do not work, radio shows OBD2 Error 1 or Error 2.	<p>Ensure OBDII connector is securely attached to the OBDII connector of the vehicle.</p> <p>If you hardwired connections at the OBDII, check connections at the OBDII connector. Make sure the RED/BROWN wire is on PIN 6 and the YELLOW/BROWN wire is connected to PIN 14 of the OBDII connector. Do not use T-Taps. Soldering or military splicing methods are recommended.</p> <p>If anything else is connected to the OBD2 or CAN wires of vehicle (programmer, throttle controller, insurance tracker, etc.) try unplugging it to see if gauges work. If gauges work without it installed, call tech support for options.</p> <p>Reset the RR.</p>
The light on the Maestro is blinking RED TWICE and the radio IS turning on.	<p>Ensure the 4-pin data cable is connected between the radio and the RR, and that it is plugged into the black port on the Maestro RR. The red and blue ports on the RR should be empty.</p> <p>Make sure the correct radio model and serial number were entered during the flash. Verify the radio's serial number entered during the flash matches what is listed on the radio screen. This can be found in the settings of the radio, listed as Device Id, Device Number, or Serial Number.</p>
The light on the Maestro is blinking RED TWICE but the radio is NOT turning on.	<p>If installing a modular radio and it is not turning on, ensure the screen is secured and any trim pieces on the radio have been installed fully. Not installing these fully will prevent radio from powering up and show a 2x red error as well.</p> <p>Test red and yellow wires for DC voltage at radio using a multimeter. Contact support if no voltage on red or yellow.</p>
The steering wheel controls are not working, the Maestro RR does not blink when they are pressed.	<p>Ensure the 20 or 28-pin connector is plugged to the vehicle and to the T01 T-harness, as shown in step 3 (this is where the RR gets the steering wheel signal from the vehicle).</p>
(Prius only) After the car is turned off, the radio stays on. The car stays in accessory mode and will not turn off.	<p>Locate the white 12-pin connector of the T01 harness, it is connected to the vehicle harness.</p> <p>Then, cut and isolate the red wire located at pin 11. The radio will shut off when the vehicle is turned off.</p>

MAESTRO RR RESET PROCEDURE:

Turn the key to the OFF position, then disconnect all connectors from the module.

Press and hold the module's programming button and connect all the connectors back to the module. Wait, the module's LED will flash RED rapidly (this may take up to 10 seconds).

Release the programming button. Wait, the LED will turn solid GREEN for 2 seconds to show the reset was successful.

TECHNICAL ASSISTANCE

Phone: 1-866-427-2999

Email: maestro.support@idatalink.com

IMPORTANT: To ensure proper operation, the aftermarket radio needs to have the latest firmware from the manufacturer. Please visit the radio manufacturer's website and look for any updates pertaining to your radio.

RETAINS STEERING WHEEL CONTROLS, FACTORY AMPLIFIER, AND MORE!



PRODUCTS REQUIRED

iDatalink Maestro RR or RR2 Radio Replacement Interface
iDatalink Maestro HRR-T01 Installation Harness

PROGRAMMED FIRMWARE

ADS-RR(SR)-TOY01-DS

ADDITIONAL RESOURCES

[Maestro RR2 Programmable Outputs Guide](#)

OPTIONAL ACCESSORIES

K40[™]
ELECTRONICS
ESCORT

Click here for:
[Radar Installation Guides](#)

HEAD UNIT ADAPTER:
ACC-HU-PI01, SON1, KEN1, KEN2, ALP1

WELCOME

Congratulations on the purchase of your iDatalink Maestro RR Radio replacement solution. You are now a few simple steps away from enjoying your new car radio with enhanced features.

Before starting your installation, please ensure that your iDatalink Maestro module is programmed with the correct firmware for your vehicle and that you carefully review the install guide.

Please note that Maestro RR will only retain functionalities that were originally available in the vehicle.

TABLE OF CONTENTS

Installation Instructions	3
Wiring Diagram	4
Radio Wire Reference Chart	5
Module Diagnostics	6
Troubleshooting Table	7

NEED HELP?

 1 866 427-2999

 maestro.support@idatalink.com

INSTALLATION INSTRUCTIONS P1/1

STEP 1

Remove the factory radio

If using head unit adapter (sold separately), connect HRR-T01 harness to adapter and skip to step 2.

- Unbox the aftermarket radio and locate its main harness.
- Cut and remove the black 20 pin connector from the HRR-T01 T-harness and connect the wires, shown in the wiring diagram, from aftermarket radio main harness to the HRR-T01 T-harness and match the wire functions.

Note: only connect purple/white wire to radio reverse input or module damage will occur.

STEP 2

- If the vehicle is equipped with an OEM backup camera, connect the HRR-T01 harness to HRR adapter cable **D**, then connect to the backup camera harness.

STEP 3

- Identify if your vehicle has a 20 or 28 pin secondary connector.
- Assemble T01 T-harness as shown on wiring diagram. Unplug 2-pin red connectors.
- Connect the factory harness to the HRR-T01 harness.

STEP 4

- Connect HRR-T01 3-pin black connector to black connector of OBDII extension harness.
- Plug the OBDII connector into the OBDII of the vehicle.

STEP 5

- Plug the harnesses into the aftermarket radio.
- Connect the backup camera RCA cable into the aftermarket radio (if equipped).
- Plug the Data cable to the data port of the aftermarket radio.
- Insert the Audio cable into the iDatalink 3.5 mm audio jack of the aftermarket radio (if there is no iDatalink audio input, connect to AUX).

Note: On Pioneer radio, ensure that there is nothing plugged into the W/R port.

STEP 6

- Connect all the harnesses to the Maestro RR module then test your installation.

WIRING DIAGRAM *without an Amplifier*

STEP 1

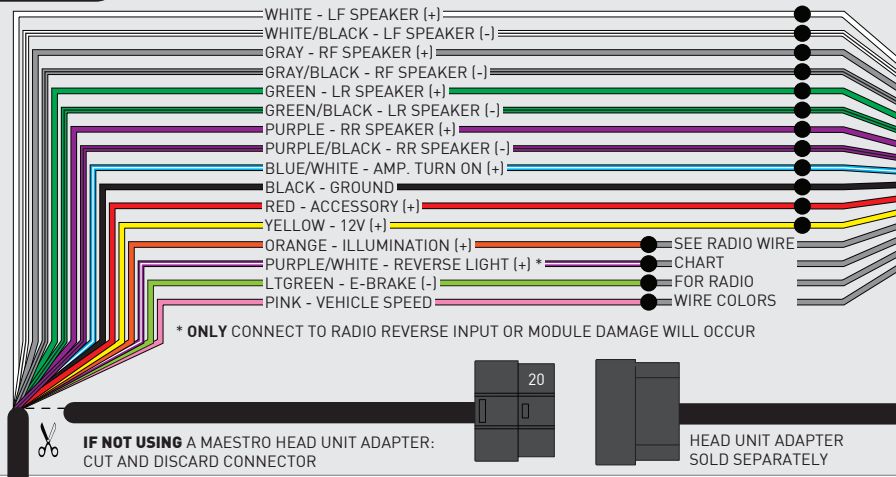

STEP 5

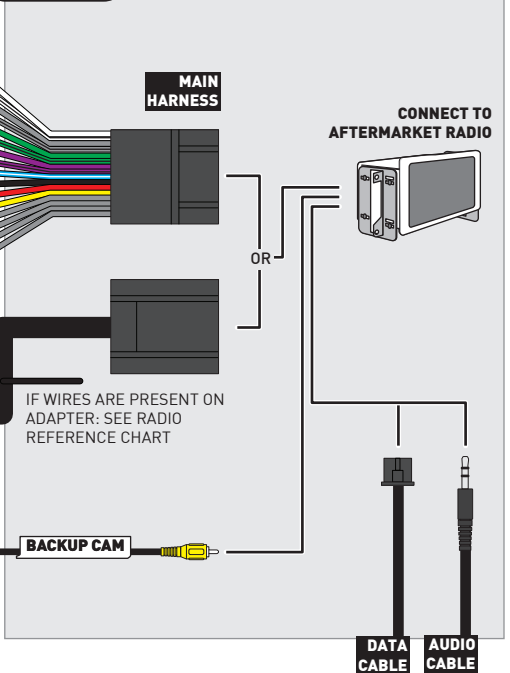

STEP 2

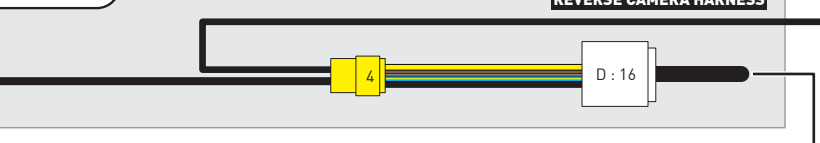

STEP 3

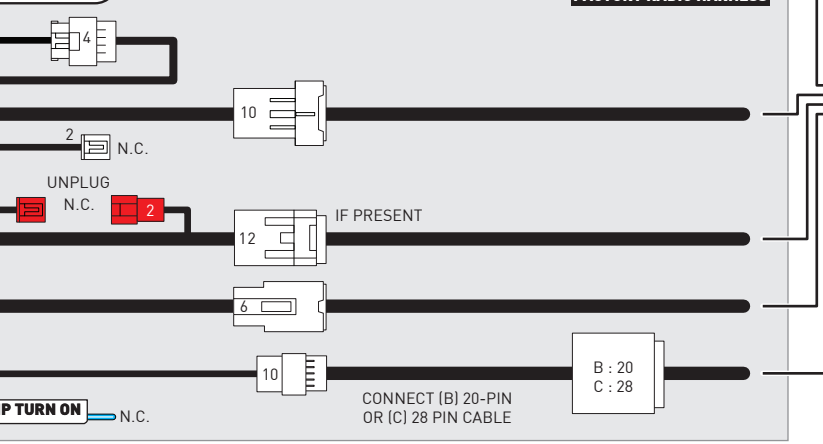

STEP 4



STEP 6

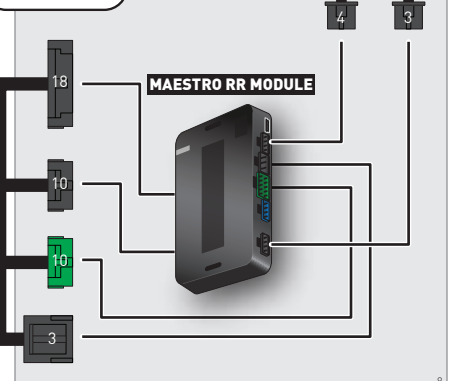

NOT REQUIRED

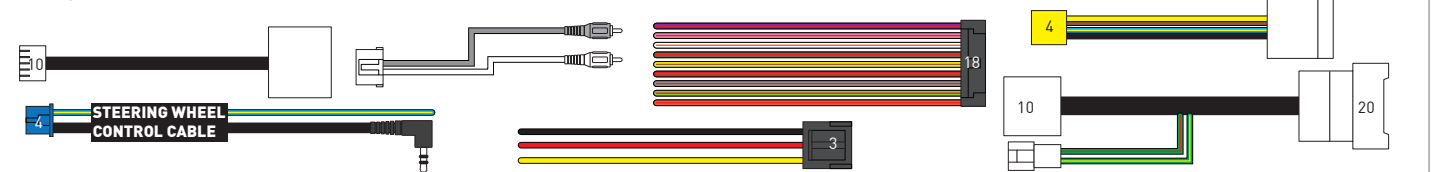

RADIO WIRE REFERENCE CHART

T01 T-harness Wire Description	Polarity	Wire Color on Maestro T-Harness	Wire Color on Alpine cable	Wire Color on Kenwood/ JVC cable	Wire Color on Pioneer cable	Wire Color on Sony cable
Illumination	(+)	Orange	N/A	Orange/White	Orange/White	Orange
Reverse Light*	(+)	Purple/White	Orange/White	Purple/White	Purple/White	Purple/White
E-Brake	(-)	Lt Green	Yellow/Blue	Lt Green	Lt Green	Lt Green
VSS (vehicle speed sensor)	(DATA)	Pink	Green/White	Pink	Pink	N/A

Head unit adapter wiring (optional accessory, sold separately)

ACC-HU-ALP1 Wire Description	Polarity	Wire Color on Adapter	Alpine Radio
VSS (vehicle speed sensor)	(DATA)	Green/White	Green/White

ACC-HU-KEN1 Wire Description	Polarity	Wire Color on Adapter	Kenwood Radio
CAM	(+)	Green/Red	Refer to camera/radio manual
CAM	(-)	Green/White	Refer to camera/radio manual
Steering Wheel Controls	(DATA)	Blue/Yellow	n/a

ACC-HU-KEN2 Wire Description	Polarity	Wire Color on Adapter	Kenwood Radio
E-Brake	(-)	LtGreen	LtGreen
Reverse Light*	(+)	Purple/White	Purple/White
Steering Wheel Controls	(DATA)	Blue/Yellow	n/a

* Reverse light wire: Only connect to radio or module damage will occur.

MODULE DIAGNOSTICS



LED 1 Module/Firmware status	LED 2 (RR2) Bluetooth activity	LED STATUS	DIAGNOSTIC
or		RED or GREEN flashing	LED flashes 1 or more times, either red or green, when a steering wheel button is pressed : normal operation.
		1 RED flash	Module has no firmware. Flash module using Weblink Desktop and log in. Do <u>NOT</u> use DEMO MODE.
		2 RED flashes	Problem detected. Consult troubleshooting table.
		1 GREEN flash	After radio boots up : Normal operation.
		3 GREEN flashes	Bluetooth is activated. Turns off after one minute: Normal operation.
		OFF	Normal operation (inactive).

VIDEO HELP		Installation, product information, vehicle specific videos.
VERIFY FLASH		Last flash information, steering control configuration, vehicle information.
WEBLINK		Software to program module.

TROUBLESHOOTING TABLE

PROBLEM	SOLUTION
Gauges do not work, radio shows OBD2 Error 1 or Error 2.	<p>Ensure OBDII connector is securely attached to the OBDII connector of the vehicle.</p> <p>If you hardwired connections at the OBDII, check connections at the OBDII connector. Make sure the RED/BROWN wire is on PIN 6 and the YELLOW/BROWN wire is connected to PIN 14 of the OBDII connector. Do not use T-Taps. Soldering or military splicing methods are recommended.</p> <p>If anything else is connected to the OBD2 or CAN wires of vehicle (programmer, throttle controller, insurance tracker, etc.) try unplugging it to see if gauges work. If gauges work without it installed, call tech support for options.</p> <p>Reset the RR.</p>
The light on the Maestro is blinking RED TWICE and the radio IS turning on.	<p>Ensure the 4-pin data cable is connected between the radio and the RR, and that it is plugged into the black port on the Maestro RR. The red and blue ports on the RR should be empty.</p> <p>Make sure the correct radio model and serial number were entered during the flash. Verify the radio's serial number entered during the flash matches what is listed on the radio screen. This can be found in the settings of the radio, listed as Device Id, Device Number, or Serial Number.</p>
The light on the Maestro is blinking RED TWICE but the radio is NOT turning on.	<p>If installing a modular radio and it is not turning on, ensure the screen is secured and any trim pieces on the radio have been installed fully. Not installing these fully will prevent radio from powering up and show a 2x red error as well.</p> <p>Test red and yellow wires for DC voltage at radio using a multimeter. Contact support if no voltage on red or yellow.</p>
The steering wheel controls are not working, the Maestro RR does not blink when they are pressed.	<p>Ensure the 20 or 28-pin connector is plugged to the vehicle and to the T01 T-harness, as shown in step 3 (this is where the RR gets the steering wheel signal from the vehicle).</p>
(Prius only) After the car is turned off, the radio stays on. The car stays in accessory mode and will not turn off.	<p>Locate the white 12-pin connector of the T01 harness, it is connected to the vehicle harness.</p> <p>Then, cut and isolate the red wire located at pin 11. The radio will shut off when the vehicle is turned off.</p>

MAESTRO RR RESET PROCEDURE:

Turn the key to the OFF position, then disconnect all connectors from the module.

Press and hold the module's programming button and connect all the connectors back to the module. Wait, the module's LED will flash RED rapidly (this may take up to 10 seconds).

Release the programming button. Wait, the LED will turn solid GREEN for 2 seconds to show the reset was successful.

TECHNICAL ASSISTANCE

Phone: 1-866-427-2999

Email: maestro.support@idatalink.com

IMPORTANT: To ensure proper operation, the aftermarket radio needs to have the latest firmware from the manufacturer. Please visit the radio manufacturer's website and look for any updates pertaining to your radio.

RETAINS STEERING WHEEL CONTROLS, FACTORY AMPLIFIER, AND MORE!



PRODUCTS REQUIRED

iDatalink Maestro RR or RR2 Radio Replacement Interface
iDatalink Maestro HRR-T01 Installation Harness

PROGRAMMED FIRMWARE

ADS-RR(SR)-TOY01-DS

ADDITIONAL RESOURCES

[Maestro RR2 Programmable Outputs Guide](#)

OPTIONAL ACCESSORIES

K40[™]
ELECTRONICS
ESCORT

Click here for:
[Radar Installation Guides](#)

HEAD UNIT ADAPTER:
ACC-HU-PI01, SON1, KEN1, KEN2, ALP1

WELCOME

Congratulations on the purchase of your iDatalink Maestro RR Radio replacement solution. You are now a few simple steps away from enjoying your new car radio with enhanced features.

Before starting your installation, please ensure that your iDatalink Maestro module is programmed with the correct firmware for your vehicle and that you carefully review the install guide.

Please note that Maestro RR will only retain functionalities that were originally available in the vehicle.

TABLE OF CONTENTS

Installation Instructions	3
Wiring Diagram	4
Radio Wire Reference Chart	5
Module Diagnostics	6
Troubleshooting Table	7

NEED HELP?

 1 866 427-2999

 maestro.support@idatalink.com

INSTALLATION INSTRUCTIONS P1/1

STEP 1

Remove the factory radio

If using head unit adapter (sold separately), connect HRR-T01 harness to adapter and skip to step 2.

- Unbox the aftermarket radio and locate its main harness.
- Cut and remove the black 20 pin connector from the HRR-T01 T-harness and connect the wires, shown in the wiring diagram, from aftermarket radio main harness to the HRR-T01 T-harness and match the wire functions.

Note: only connect purple/white wire to radio reverse input or module damage will occur.

STEP 2

- If the vehicle is equipped with an OEM backup camera, connect the HRR-T01 harness to HRR adapter cable **D**, then connect to the backup camera harness.

STEP 3

- Identify if your vehicle has a 20 or 28 pin secondary connector.
- Assemble T01 T-harness as shown on wiring diagram. Unplug 2-pin red connectors.
- Connect the factory harness to the HRR-T01 harness.

STEP 4

- Connect HRR-T01 3-pin black connector to black connector of OBDII extension harness.
- Plug the OBDII connector into the OBDII of the vehicle.

STEP 5

- Plug the harnesses into the aftermarket radio.
- Connect the backup camera RCA cable into the aftermarket radio (if equipped).
- Connect the left front and right front low level outputs RCA cables into the aftermarket radio.
- Plug the Data cable to the data port of the aftermarket radio.
- Insert the Audio cable into the iDatalink 3.5 mm audio jack of the aftermarket radio (if there is no iDatalink audio input, connect to AUX).

Note: On Pioneer radio, ensure that there is nothing plugged into the W/R port.

STEP 6

- Connect all the harnesses to the Maestro RR module then test your installation.

WIRING DIAGRAM *with an Amplifier*

STEP 1

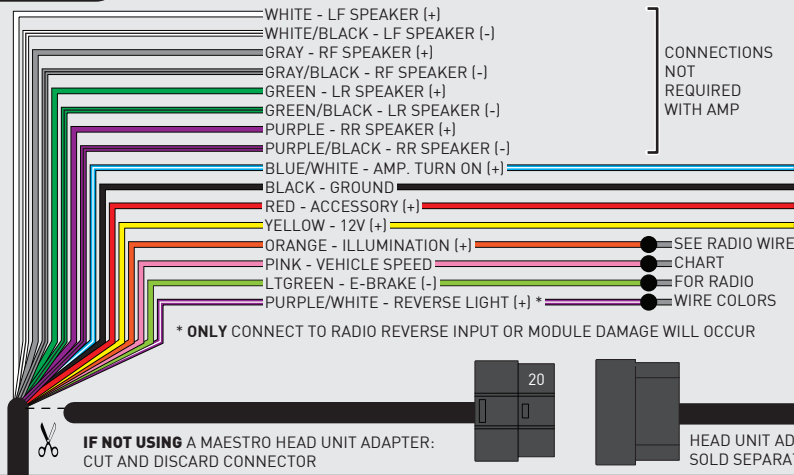

STEP 5

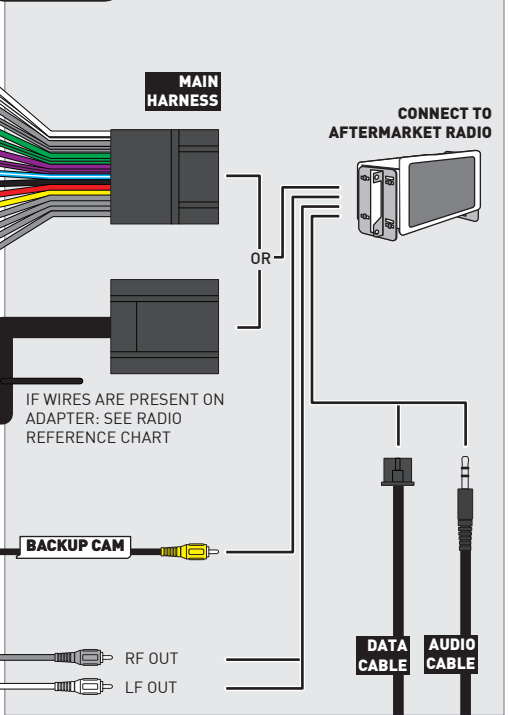

STEP 2

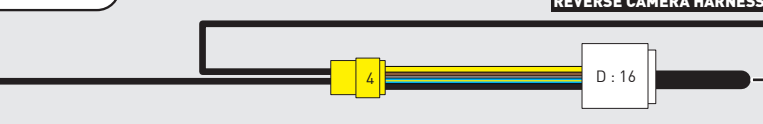

STEP 3

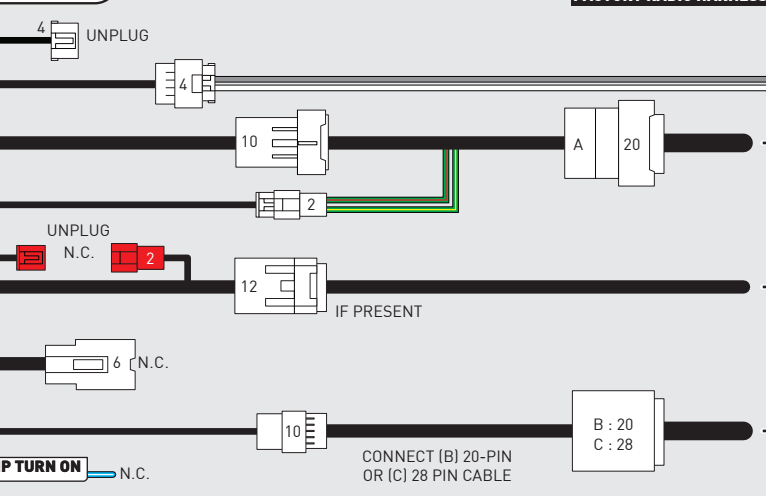

STEP 4



STEP 6

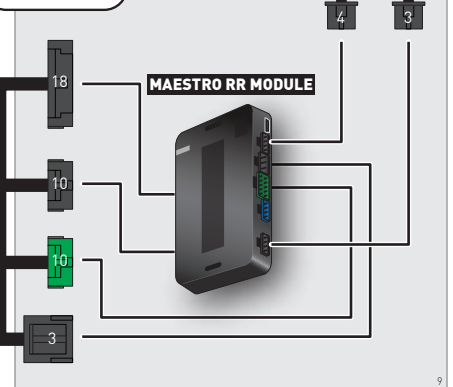

NOT REQUIRED

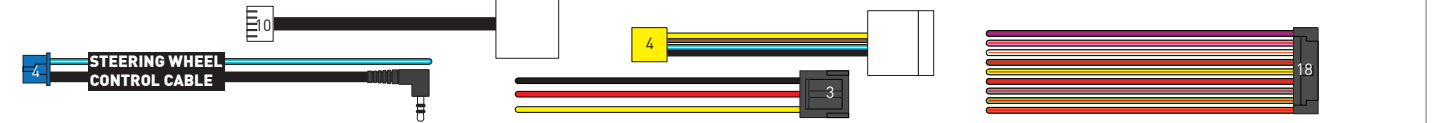

RADIO WIRE REFERENCE CHART

T01 T-harness Wire Description	Polarity	Wire Color on Maestro T-Harness	Wire Color on Alpine cable	Wire Color on Kenwood/ JVC cable	Wire Color on Pioneer cable	Wire Color on Sony cable
Illumination	(+)	Orange	N/A	Orange/White	Orange/White	Orange
Reverse Light*	(+)	Purple/White	Orange/White	Purple/White	Purple/White	Purple/White
E-Brake	(-)	Lt Green	Yellow/Blue	Lt Green	Lt Green	Lt Green
VSS (vehicle speed sensor)	(DATA)	Pink	Green/White	Pink	Pink	N/A

Head unit adapter wiring (optional accessory, sold separately)

ACC-HU-ALP1 Wire Description	Polarity	Wire Color on Adapter	Alpine Radio
VSS (vehicle speed sensor)	(DATA)	Green/White	Green/White

ACC-HU-KEN1 Wire Description	Polarity	Wire Color on Adapter	Kenwood Radio
CAM	(+)	Green/Red	Refer to camera/radio manual
CAM	(-)	Green/White	Refer to camera/radio manual
Steering Wheel Controls	(DATA)	Blue/Yellow	n/a

ACC-HU-KEN2 Wire Description	Polarity	Wire Color on Adapter	Kenwood Radio
E-Brake	(-)	LtGreen	LtGreen
Reverse Light*	(+)	Purple/White	Purple/White
Steering Wheel Controls	(DATA)	Blue/Yellow	n/a

* Reverse light wire: Only connect to radio or module damage will occur.

MODULE DIAGNOSTICS



LED 1 Module/Firmware status	LED 2 (RR2) Bluetooth activity	LED STATUS	DIAGNOSTIC
or		RED or GREEN flashing	LED flashes 1 or more times, either red or green, when a steering wheel button is pressed : normal operation.
		1 RED flash	Module has no firmware. Flash module using Weblink Desktop and log in. Do <u>NOT</u> use DEMO MODE.
		2 RED flashes	Problem detected. Consult troubleshooting table.
		1 GREEN flash	After radio boots up : Normal operation.
		3 GREEN flashes	Bluetooth is activated. Turns off after one minute: Normal operation.
		OFF	Normal operation (inactive).

VIDEO HELP		Installation, product information, vehicle specific videos.
VERIFY FLASH		Last flash information, steering control configuration, vehicle information.
WEBLINK		Software to program module.

TROUBLESHOOTING TABLE

PROBLEM	SOLUTION
Gauges do not work, radio shows OBD2 Error 1 or Error 2.	<p>Ensure OBDII connector is securely attached to the OBDII connector of the vehicle.</p> <p>If you hardwired connections at the OBDII, check connections at the OBDII connector. Make sure the RED/BROWN wire is on PIN 6 and the YELLOW/BROWN wire is connected to PIN 14 of the OBDII connector. Do not use T-Taps. Soldering or military splicing methods are recommended.</p> <p>If anything else is connected to the OBD2 or CAN wires of vehicle (programmer, throttle controller, insurance tracker, etc.) try unplugging it to see if gauges work. If gauges work without it installed, call tech support for options.</p> <p>Reset the RR.</p>
The light on the Maestro is blinking RED TWICE and the radio IS turning on.	<p>Ensure the 4-pin data cable is connected between the radio and the RR, and that it is plugged into the black port on the Maestro RR. The red and blue ports on the RR should be empty.</p> <p>Make sure the correct radio model and serial number were entered during the flash. Verify the radio's serial number entered during the flash matches what is listed on the radio screen. This can be found in the settings of the radio, listed as Device Id, Device Number, or Serial Number.</p>
The light on the Maestro is blinking RED TWICE but the radio is NOT turning on.	<p>If installing a modular radio and it is not turning on, ensure the screen is secured and any trim pieces on the radio have been installed fully. Not installing these fully will prevent radio from powering up and show a 2x red error as well.</p> <p>Test red and yellow wires for DC voltage at radio using a multimeter. Contact support if no voltage on red or yellow.</p>
The steering wheel controls are not working, the Maestro RR does not blink when they are pressed.	<p>Ensure the 20 or 28-pin connector is plugged to the vehicle and to the T01 T-harness, as shown in step 3 (this is where the RR gets the steering wheel signal from the vehicle).</p>
(Prius only) After the car is turned off, the radio stays on. The car stays in accessory mode and will not turn off.	<p>Locate the white 12-pin connector of the T01 harness, it is connected to the vehicle harness.</p> <p>Then, cut and isolate the red wire located at pin 11. The radio will shut off when the vehicle is turned off.</p>

MAESTRO RR RESET PROCEDURE:

Turn the key to the OFF position, then disconnect all connectors from the module.

Press and hold the module's programming button and connect all the connectors back to the module. Wait, the module's LED will flash RED rapidly (this may take up to 10 seconds).

Release the programming button. Wait, the LED will turn solid GREEN for 2 seconds to show the reset was successful.

TECHNICAL ASSISTANCE

Phone: 1-866-427-2999

Email: maestro.support@idatalink.com

IMPORTANT: To ensure proper operation, the aftermarket radio needs to have the latest firmware from the manufacturer. Please visit the radio manufacturer's website and look for any updates pertaining to your radio.

RETAINS STEERING WHEEL CONTROLS, FACTORY AMPLIFIER, AND MORE!

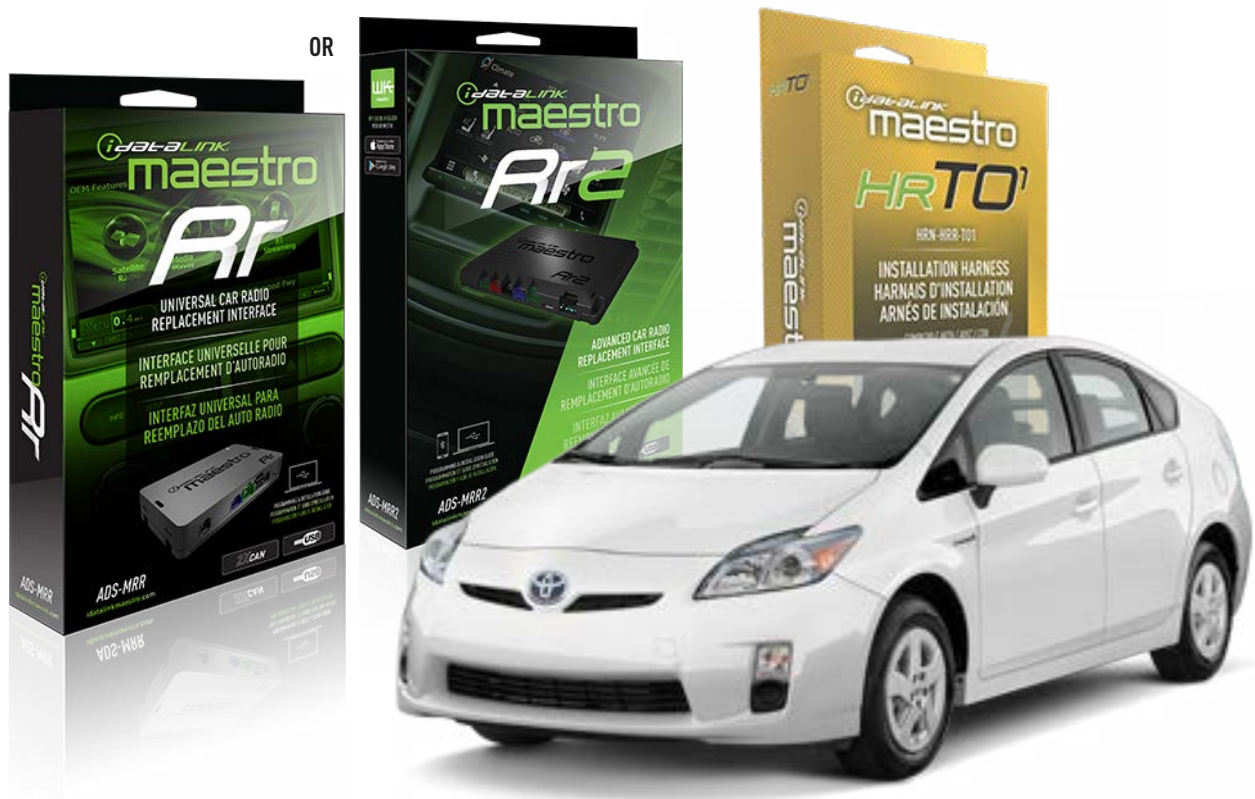

PRODUCTS REQUIRED

iDatalink Maestro RR or RR2 Radio Replacement Interface
iDatalink Maestro HRR-T01 Installation Harness

PROGRAMMED FIRMWARE

ADS-RR(SR)-TOY01-DS

ADDITIONAL RESOURCES

[Maestro RR2 Programmable Outputs Guide](#)

OPTIONAL ACCESSORIES

K40[™]
ELECTRONICS
ESCORT

Click here for:
[Radar Installation Guides](#)

HEAD UNIT ADAPTER:
ACC-HU-PI01, SON1, KEN1, KEN2, ALP1

WELCOME

Congratulations on the purchase of your iDatalink Maestro RR Radio replacement solution. You are now a few simple steps away from enjoying your new car radio with enhanced features.

Before starting your installation, please ensure that your iDatalink Maestro module is programmed with the correct firmware for your vehicle and that you carefully review the install guide.

Please note that Maestro RR will only retain functionalities that were originally available in the vehicle.

TABLE OF CONTENTS

Installation Instructions	3
Wiring Diagram	4
Radio Wire Reference Chart	5
Module Diagnostics	6
Troubleshooting Table	7

NEED HELP?

 1 866 427-2999

 maestro.support@idatalink.com

INSTALLATION INSTRUCTIONS P1/1

STEP 1

Remove the factory radio

If using head unit adapter (sold separately), connect HRR-TO1 harness to adapter and skip to step 2.

- Unbox the aftermarket radio and locate its main harness.
- Cut and remove the black 20 pin connector from the HRR-TO1 T-harness and connect the wires, shown in the wiring diagram, from aftermarket radio main harness to the HRR-TO1 T-harness and match the wire functions.

Note: only connect purple/white wire to radio reverse input or module damage will occur.

STEP 2

- If the vehicle is equipped with an OEM backup camera, connect the HRR-TO1 harness to HRR adapter cable **D**, then connect to the backup camera harness.

STEP 3

- Identify if your vehicle has a 20 or 28 pin secondary connector.
- Assemble TO1 T-harness as shown on wiring diagram. Unplug 2-pin red connectors.
- Connect the factory harness to the HRR-TO1 harness.

STEP 4

- Connect HRR-TO1 3-pin black connector to black connector of OBDII extension harness.
- Plug the OBDII connector into the OBDII of the vehicle.

STEP 5

- Plug the harnesses into the aftermarket radio.
- Connect the backup camera RCA cable into the aftermarket radio (if equipped).
- Plug the Data cable to the data port of the aftermarket radio.
- Insert the Audio cable into the iDatalink 3.5 mm audio jack of the aftermarket radio (if there is no iDatalink audio input, connect to AUX).

Note: On Pioneer radio, ensure that there is nothing plugged into the W/R port.

STEP 6

- Connect all the harnesses to the Maestro RR module then test your installation.

WIRING DIAGRAM *without an Amplifier*

STEP 1

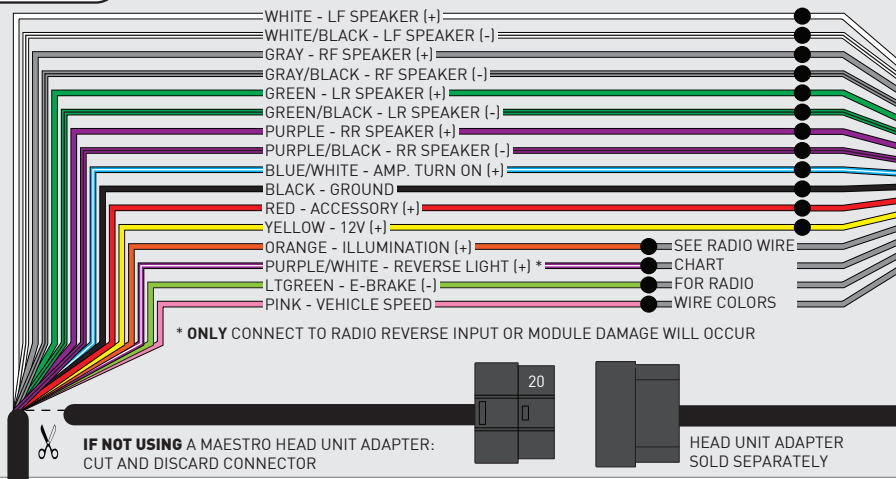

STEP 5

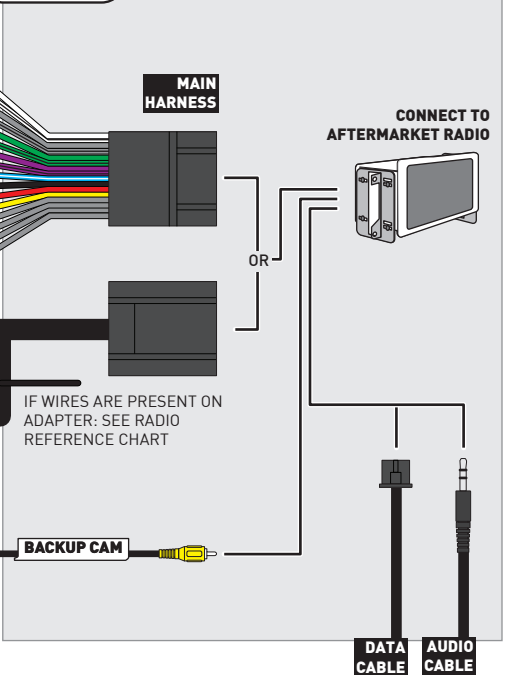

STEP 2

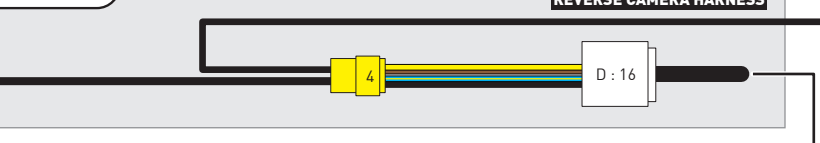

STEP 3

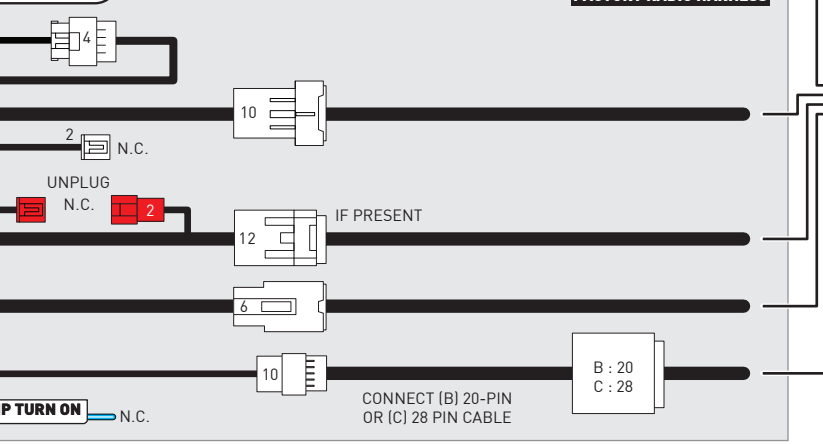

STEP 4



STEP 6

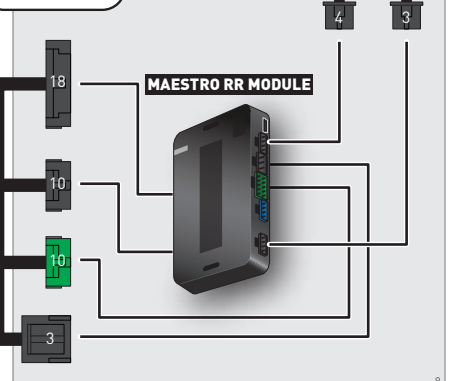

NOT REQUIRED

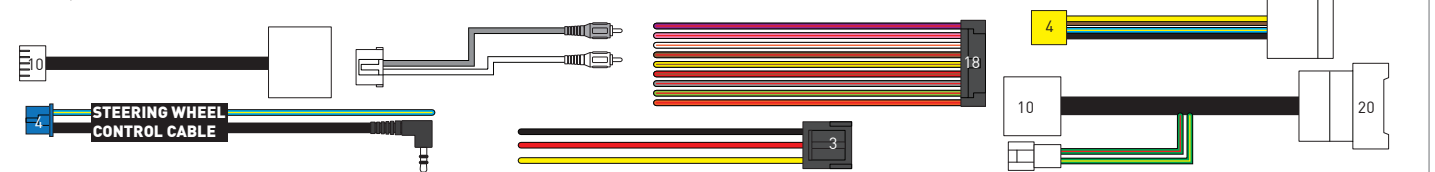

RADIO WIRE REFERENCE CHART

T01 T-harness Wire Description	Polarity	Wire Color on Maestro T-Harness	Wire Color on Alpine cable	Wire Color on Kenwood/JVC cable	Wire Color on Pioneer cable	Wire Color on Sony cable
Illumination	(+)	Orange	N/A	Orange/White	Orange/White	Orange
Reverse Light*	(+)	Purple/White	Orange/White	Purple/White	Purple/White	Purple/White
E-Brake	(-)	Lt Green	Yellow/Blue	Lt Green	Lt Green	Lt Green
VSS (vehicle speed sensor)	(DATA)	Pink	Green/White	Pink	Pink	N/A

Head unit adapter wiring (optional accessory, sold separately)

ACC-HU-ALP1 Wire Description	Polarity	Wire Color on Adapter	Alpine Radio
VSS (vehicle speed sensor)	(DATA)	Green/White	Green/White

ACC-HU-KEN1 Wire Description	Polarity	Wire Color on Adapter	Kenwood Radio
CAM	(+)	Green/Red	Refer to camera/radio manual
CAM	(-)	Green/White	Refer to camera/radio manual
Steering Wheel Controls	(DATA)	Blue/Yellow	n/a

ACC-HU-KEN2 Wire Description	Polarity	Wire Color on Adapter	Kenwood Radio
E-Brake	(-)	LtGreen	LtGreen
Reverse Light*	(+)	Purple/White	Purple/White
Steering Wheel Controls	(DATA)	Blue/Yellow	n/a

* Reverse light wire: Only connect to radio or module damage will occur.

MODULE DIAGNOSTICS



LED 1 Module/Firmware status	LED 2 (RR2) Bluetooth activity	LED STATUS	DIAGNOSTIC
or		RED or GREEN flashing	LED flashes 1 or more times, either red or green, when a steering wheel button is pressed : normal operation.
		1 RED flash	Module has no firmware. Flash module using Weblink Desktop and log in. Do <u>NOT</u> use DEMO MODE.
		2 RED flashes	Problem detected. Consult troubleshooting table.
		1 GREEN flash	After radio boots up : Normal operation.
		3 GREEN flashes	Bluetooth is activated. Turns off after one minute: Normal operation.
		OFF	Normal operation (inactive).

VIDEO HELP		Installation, product information, vehicle specific videos.
VERIFY FLASH		Last flash information, steering control configuration, vehicle information.
WEBLINK		Software to program module.

TROUBLESHOOTING TABLE

PROBLEM	SOLUTION
Gauges do not work, radio shows OBD2 Error 1 or Error 2.	<p>Ensure OBDII connector is securely attached to the OBDII connector of the vehicle.</p> <p>If you hardwired connections at the OBDII, check connections at the OBDII connector. Make sure the RED/BROWN wire is on PIN 6 and the YELLOW/BROWN wire is connected to PIN 14 of the OBDII connector. Do not use T-Taps. Soldering or military splicing methods are recommended.</p> <p>If anything else is connected to the OBD2 or CAN wires of vehicle (programmer, throttle controller, insurance tracker, etc.) try unplugging it to see if gauges work. If gauges work without it installed, call tech support for options.</p> <p>Reset the RR.</p>
The light on the Maestro is blinking RED TWICE and the radio IS turning on.	<p>Ensure the 4-pin data cable is connected between the radio and the RR, and that it is plugged into the black port on the Maestro RR. The red and blue ports on the RR should be empty.</p> <p>Make sure the correct radio model and serial number were entered during the flash. Verify the radio's serial number entered during the flash matches what is listed on the radio screen. This can be found in the settings of the radio, listed as Device Id, Device Number, or Serial Number.</p>
The light on the Maestro is blinking RED TWICE but the radio is NOT turning on.	<p>If installing a modular radio and it is not turning on, ensure the screen is secured and any trim pieces on the radio have been installed fully. Not installing these fully will prevent radio from powering up and show a 2x red error as well.</p> <p>Test red and yellow wires for DC voltage at radio using a multimeter. Contact support if no voltage on red or yellow.</p>
The steering wheel controls are not working, the Maestro RR does not blink when they are pressed.	<p>Ensure the 20 or 28-pin connector is plugged to the vehicle and to the T01 T-harness, as shown in step 3 (this is where the RR gets the steering wheel signal from the vehicle).</p>
(Prius only) After the car is turned off, the radio stays on. The car stays in accessory mode and will not turn off.	<p>Locate the white 12-pin connector of the T01 harness, it is connected to the vehicle harness.</p> <p>Then, cut and isolate the red wire located at pin 11. The radio will shut off when the vehicle is turned off.</p>

MAESTRO RR RESET PROCEDURE:

Turn the key to the OFF position, then disconnect all connectors from the module.

Press and hold the module's programming button and connect all the connectors back to the module. Wait, the module's LED will flash RED rapidly (this may take up to 10 seconds).

Release the programming button. Wait, the LED will turn solid GREEN for 2 seconds to show the reset was successful.

TECHNICAL ASSISTANCE

Phone: 1-866-427-2999

Email: maestro.support@idatalink.com

IMPORTANT: To ensure proper operation, the aftermarket radio needs to have the latest firmware from the manufacturer. Please visit the radio manufacturer's website and look for any updates pertaining to your radio.

RETAINS STEERING WHEEL CONTROLS, FACTORY AMPLIFIER, AND MORE!



PRODUCTS REQUIRED

iDatalink Maestro RR or RR2 Radio Replacement Interface
iDatalink Maestro HRR-T01 Installation Harness

PROGRAMMED FIRMWARE

ADS-RR(SR)-TOY01-DS

ADDITIONAL RESOURCES

[Maestro RR2 Programmable Outputs Guide](#)

OPTIONAL ACCESSORIES

K40[™]
ELECTRONICS
ESCORT

Click here for:
[Radar Installation Guides](#)

HEAD UNIT ADAPTER:
ACC-HU-PI01, SON1, KEN1, KEN2, ALP1

WELCOME

Congratulations on the purchase of your iDatalink Maestro RR Radio replacement solution. You are now a few simple steps away from enjoying your new car radio with enhanced features.

Before starting your installation, please ensure that your iDatalink Maestro module is programmed with the correct firmware for your vehicle and that you carefully review the install guide.

Please note that Maestro RR will only retain functionalities that were originally available in the vehicle.

TABLE OF CONTENTS

Installation Instructions	3
Wiring Diagram	4
Radio Wire Reference Chart	5
Module Diagnostics	6
Troubleshooting Table	7

NEED HELP?

 1 866 427-2999

 maestro.support@idatalink.com

INSTALLATION INSTRUCTIONS P1/1

STEP 1

Remove the factory radio

If using head unit adapter (sold separately), connect HRR-T01 harness to adapter and skip to step 2.

- Unbox the aftermarket radio and locate its main harness.
- Cut and remove the black 20 pin connector from the HRR-T01 T-harness and connect the wires, shown in the wiring diagram, from aftermarket radio main harness to the HRR-T01 T-harness and match the wire functions.

Note: only connect purple/white wire to radio reverse input or module damage will occur.

STEP 2

- Identify if your vehicle has a 20 or 28 pin secondary connector.
- Assemble T01 T-harness as shown on wiring diagram.
- Connect the factory harness to the HRR-T01 harness.

STEP 3

- Connect HRR-T01 3-pin black connector to black connector of OBDII extension harness.
- Plug the OBDII connector into the OBDII of the vehicle.

STEP 4

- Plug the harnesses into the aftermarket radio.
- Plug the Data cable to the data port of the aftermarket radio.
- Insert the Audio cable into the iDatalink 3.5 mm audio jack of the aftermarket radio (if there is no iDatalink audio input, connect to AUX).

Note: On Pioneer radio, ensure that there is nothing plugged into the W/R port.

STEP 5

- Connect all the harnesses to the Maestro RR module then test your installation.

WIRING DIAGRAM *without an Amplifier*

STEP 1

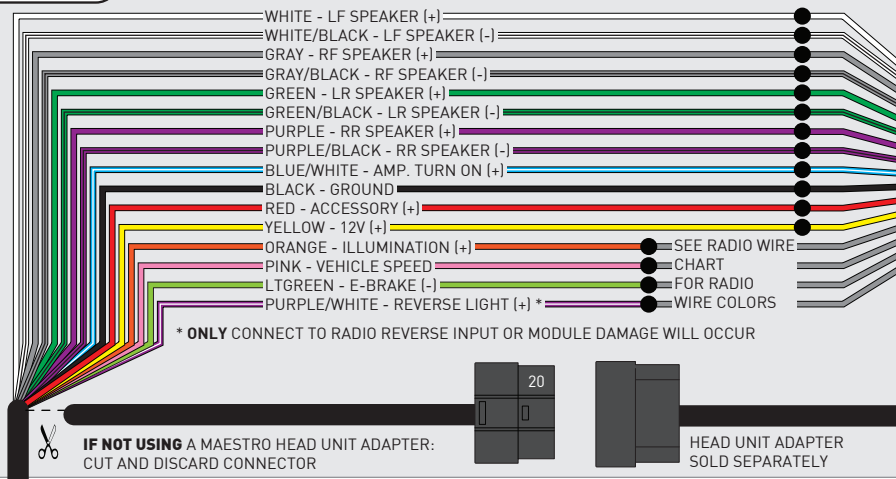

STEP 4

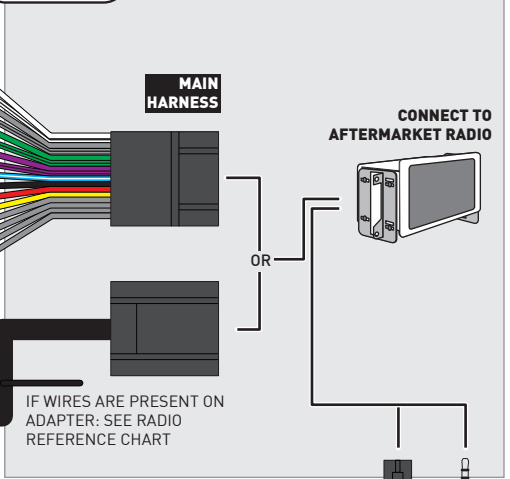

STEP 2

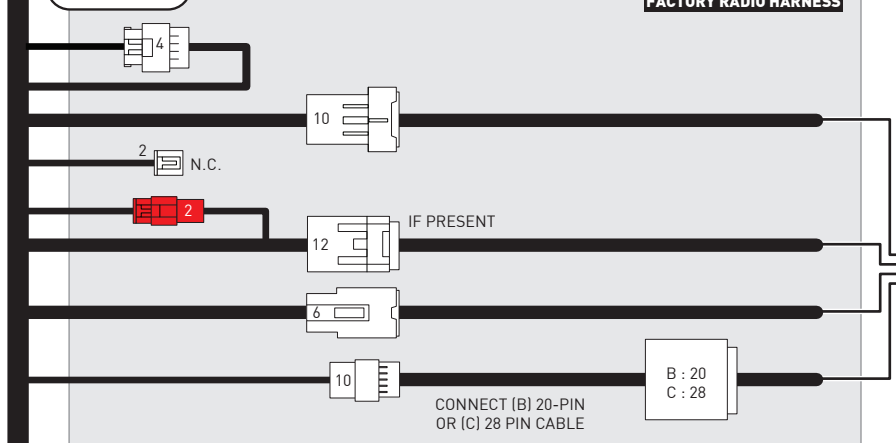

STEP 3

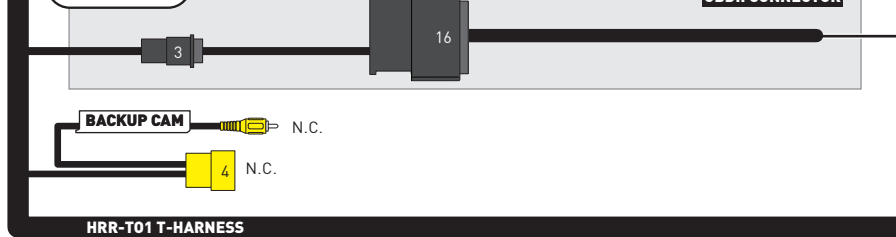

STEP 5

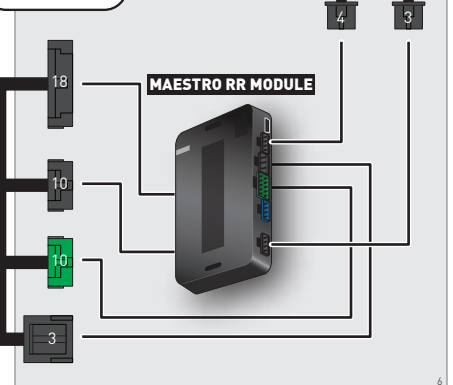

NOT REQUIRED

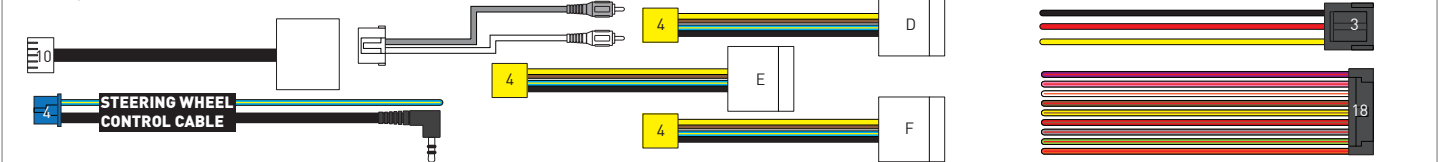

RADIO WIRE REFERENCE CHART

T01 T-harness Wire Description	Polarity	Wire Color on Maestro T-Harness	Wire Color on Alpine cable	Wire Color on Kenwood/ JVC cable	Wire Color on Pioneer cable	Wire Color on Sony cable
Illumination	(+)	Orange	N/A	Orange/White	Orange/White	Orange
Reverse Light*	(+)	Purple/White	Orange/White	Purple/White	Purple/White	Purple/White
E-Brake	(-)	Lt Green	Yellow/Blue	Lt Green	Lt Green	Lt Green
VSS (vehicle speed sensor)	(DATA)	Pink	Green/White	Pink	Pink	N/A

Head unit adapter wiring (optional accessory, sold separately)

ACC-HU-ALP1 Wire Description	Polarity	Wire Color on Adapter	Alpine Radio
VSS (vehicle speed sensor)	(DATA)	Green/White	Green/White

ACC-HU-KEN1 Wire Description	Polarity	Wire Color on Adapter	Kenwood Radio
CAM	(+)	Green/Red	Refer to camera/radio manual
CAM	(-)	Green/White	Refer to camera/radio manual
Steering Wheel Controls	(DATA)	Blue/Yellow	n/a

ACC-HU-KEN2 Wire Description	Polarity	Wire Color on Adapter	Kenwood Radio
E-Brake	(-)	LtGreen	LtGreen
Reverse Light*	(+)	Purple/White	Purple/White
Steering Wheel Controls	(DATA)	Blue/Yellow	n/a

* Reverse light wire: Only connect to radio or module damage will occur.

MODULE DIAGNOSTICS



LED 1 Module/Firmware status	LED 2 (RR2) Bluetooth activity	LED STATUS	DIAGNOSTIC
or		RED or GREEN flashing	LED flashes 1 or more times, either red or green, when a steering wheel button is pressed : normal operation.
		1 RED flash	Module has no firmware. Flash module using Weblink Desktop and log in. Do <u>NOT</u> use DEMO MODE.
		2 RED flashes	Problem detected. Consult troubleshooting table.
		1 GREEN flash	After radio boots up : Normal operation.
		3 GREEN flashes	Bluetooth is activated. Turns off after one minute: Normal operation.
		OFF	Normal operation (inactive).

VIDEO HELP		Installation, product information, vehicle specific videos.
VERIFY FLASH		Last flash information, steering control configuration, vehicle information.
WEBLINK		Software to program module.

TROUBLESHOOTING TABLE

PROBLEM	SOLUTION
Gauges do not work, radio shows OBD2 Error 1 or Error 2.	<p>Ensure OBDII connector is securely attached to the OBDII connector of the vehicle.</p> <p>If you hardwired connections at the OBDII, check connections at the OBDII connector. Make sure the RED/BROWN wire is on PIN 6 and the YELLOW/BROWN wire is connected to PIN 14 of the OBDII connector. Do not use T-Taps. Soldering or military splicing methods are recommended.</p> <p>If anything else is connected to the OBD2 or CAN wires of vehicle (programmer, throttle controller, insurance tracker, etc.) try unplugging it to see if gauges work. If gauges work without it installed, call tech support for options.</p> <p>Reset the RR.</p>
The light on the Maestro is blinking RED TWICE and the radio IS turning on.	<p>Ensure the 4-pin data cable is connected between the radio and the RR, and that it is plugged into the black port on the Maestro RR. The red and blue ports on the RR should be empty.</p> <p>Make sure the correct radio model and serial number were entered during the flash. Verify the radio's serial number entered during the flash matches what is listed on the radio screen. This can be found in the settings of the radio, listed as Device Id, Device Number, or Serial Number.</p>
The light on the Maestro is blinking RED TWICE but the radio is NOT turning on.	<p>If installing a modular radio and it is not turning on, ensure the screen is secured and any trim pieces on the radio have been installed fully. Not installing these fully will prevent radio from powering up and show a 2x red error as well.</p> <p>Test red and yellow wires for DC voltage at radio using a multimeter. Contact support if no voltage on red or yellow.</p>
The steering wheel controls are not working, the Maestro RR does not blink when they are pressed.	<p>Ensure the 20 or 28-pin connector is plugged to the vehicle and to the T01 T-harness, as shown in step 3 (this is where the RR gets the steering wheel signal from the vehicle).</p>
(Prius only) After the car is turned off, the radio stays on. The car stays in accessory mode and will not turn off.	<p>Locate the white 12-pin connector of the T01 harness, it is connected to the vehicle harness.</p> <p>Then, cut and isolate the red wire located at pin 11. The radio will shut off when the vehicle is turned off.</p>

MAESTRO RR RESET PROCEDURE:

Turn the key to the OFF position, then disconnect all connectors from the module.

Press and hold the module's programming button and connect all the connectors back to the module. Wait, the module's LED will flash RED rapidly (this may take up to 10 seconds).

Release the programming button. Wait, the LED will turn solid GREEN for 2 seconds to show the reset was successful.

TECHNICAL ASSISTANCE

Phone: 1-866-427-2999

Email: maestro.support@idatalink.com

IMPORTANT: To ensure proper operation, the aftermarket radio needs to have the latest firmware from the manufacturer. Please visit the radio manufacturer's website and look for any updates pertaining to your radio.

RETAINS STEERING WHEEL CONTROLS, FACTORY AMPLIFIER, AND MORE!



PRODUCTS REQUIRED

iDatalink Maestro RR or RR2 Radio Replacement Interface
iDatalink Maestro HRR-T01 Installation Harness

PROGRAMMED FIRMWARE

ADS-RR(SR)-TOY01-DS

ADDITIONAL RESOURCES

[Maestro RR2 Programmable Outputs Guide](#)

OPTIONAL ACCESSORIES



Click here for:
[Radar Installation Guides](#)

HEAD UNIT ADAPTER:
ACC-HU-PI01, SON1, KEN1, KEN2, ALP1

WELCOME

Congratulations on the purchase of your iDatalink Maestro RR Radio replacement solution. You are now a few simple steps away from enjoying your new car radio with enhanced features.

Before starting your installation, please ensure that your iDatalink Maestro module is programmed with the correct firmware for your vehicle and that you carefully review the install guide.

Please note that Maestro RR will only retain functionalities that were originally available in the vehicle.

TABLE OF CONTENTS

Installation Instructions	3
Wiring Diagram	4
Radio Wire Reference Chart	5
Module Diagnostics	6
Troubleshooting Table	7

NEED HELP?

 1 866 427-2999

 maestro.support@idatalink.com

INSTALLATION INSTRUCTIONS P1/1

STEP 1

Remove the factory radio

If using head unit adapter (sold separately), connect HRR-T01 harness to adapter and skip to step 2.

- Unbox the aftermarket radio and locate its main harness.
- Cut and remove the black 20 pin connector from the HRR-T01 T-harness and connect the wires, shown in the wiring diagram, from aftermarket radio main harness to the HRR-T01 T-harness and match the wire functions.

Note: only connect purple/white wire to radio reverse input or module damage will occur.

STEP 2

- Identify if your vehicle has a 20 or 28 pin secondary connector.
- Assemble T01 T-harness as shown on wiring diagram.
- Connect the factory harness to the HRR-T01 harness.

STEP 3

- Connect HRR-T01 3-pin black connector to black connector of OBDII extension harness.
- Plug the OBDII connector into the OBDII of the vehicle.

STEP 4

- Plug the harnesses into the aftermarket radio.
- Connect the left front and right front low level outputs RCA cables into the aftermarket radio.
- Plug the Data cable to the data port of the aftermarket radio.
- Insert the Audio cable into the iDatalink 3.5 mm audio jack of the aftermarket radio (if there is no iDatalink audio input, connect to AUX).

Note: On Pioneer radio, ensure that there is nothing plugged into the W/R port.

STEP 5

- Connect all the harnesses to the Maestro RR module then test your installation.

WIRING DIAGRAM *with an Amplifier*

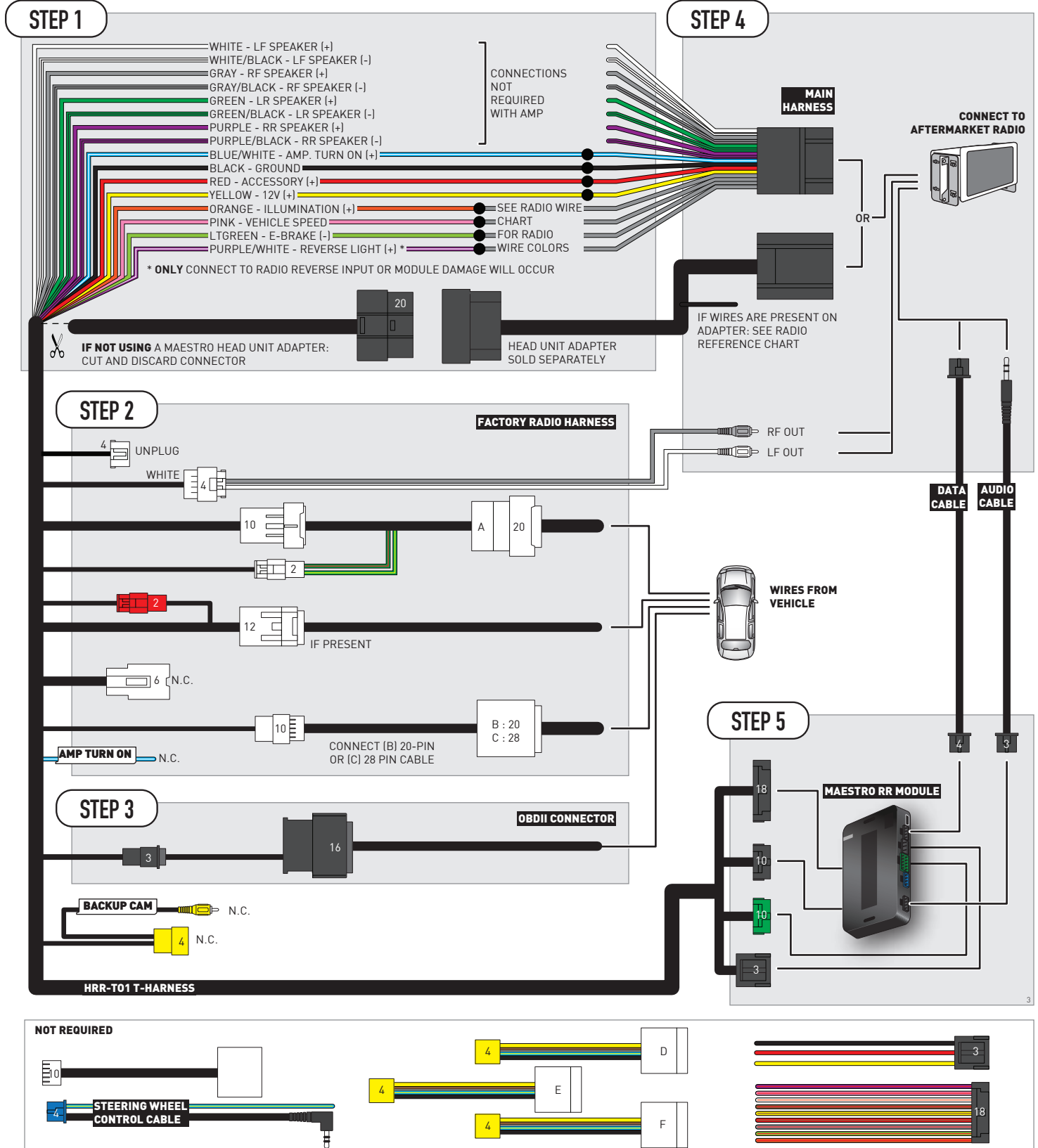

RADIO WIRE REFERENCE CHART

T01 T-harness Wire Description	Polarity	Wire Color on Maestro T-Harness	Wire Color on Alpine cable	Wire Color on Kenwood/JVC cable	Wire Color on Pioneer cable	Wire Color on Sony cable
Illumination	(+)	Orange	N/A	Orange/White	Orange/White	Orange
Reverse Light*	(+)	Purple/White	Orange/White	Purple/White	Purple/White	Purple/White
E-Brake	(-)	Lt Green	Yellow/Blue	Lt Green	Lt Green	Lt Green
VSS (vehicle speed sensor)	(DATA)	Pink	Green/White	Pink	Pink	N/A

Head unit adapter wiring (optional accessory, sold separately)

ACC-HU-ALP1 Wire Description	Polarity	Wire Color on Adapter	Alpine Radio
VSS (vehicle speed sensor)	(DATA)	Green/White	Green/White

ACC-HU-KEN1 Wire Description	Polarity	Wire Color on Adapter	Kenwood Radio
CAM	(+)	Green/Red	Refer to camera/radio manual
CAM	(-)	Green/White	Refer to camera/radio manual
Steering Wheel Controls	(DATA)	Blue/Yellow	n/a

ACC-HU-KEN2 Wire Description	Polarity	Wire Color on Adapter	Kenwood Radio
E-Brake	(-)	LtGreen	LtGreen
Reverse Light*	(+)	Purple/White	Purple/White
Steering Wheel Controls	(DATA)	Blue/Yellow	n/a

* Reverse light wire: Only connect to radio or module damage will occur.

MODULE DIAGNOSTICS



LED 1 Module/Firmware status	LED 2 (RR2) Bluetooth activity	LED STATUS	DIAGNOSTIC
or		RED or GREEN flashing	LED flashes 1 or more times, either red or green, when a steering wheel button is pressed : normal operation.
		1 RED flash	Module has no firmware. Flash module using Weblink Desktop and log in. Do <u>NOT</u> use DEMO MODE.
		2 RED flashes	Problem detected. Consult troubleshooting table.
		1 GREEN flash	After radio boots up : Normal operation.
		3 GREEN flashes	Bluetooth is activated. Turns off after one minute: Normal operation.
		OFF	Normal operation (inactive).

VIDEO HELP		Installation, product information, vehicle specific videos.
VERIFY FLASH		Last flash information, steering control configuration, vehicle information.
WEBLINK		Software to program module.

TROUBLESHOOTING TABLE

PROBLEM	SOLUTION
Gauges do not work, radio shows OBD2 Error 1 or Error 2.	<p>Ensure OBDII connector is securely attached to the OBDII connector of the vehicle.</p> <p>If you hardwired connections at the OBDII, check connections at the OBDII connector. Make sure the RED/BROWN wire is on PIN 6 and the YELLOW/BROWN wire is connected to PIN 14 of the OBDII connector. Do not use T-Taps. Soldering or military splicing methods are recommended.</p> <p>If anything else is connected to the OBD2 or CAN wires of vehicle (programmer, throttle controller, insurance tracker, etc.) try unplugging it to see if gauges work. If gauges work without it installed, call tech support for options.</p> <p>Reset the RR.</p>
The light on the Maestro is blinking RED TWICE and the radio IS turning on.	<p>Ensure the 4-pin data cable is connected between the radio and the RR, and that it is plugged into the black port on the Maestro RR. The red and blue ports on the RR should be empty.</p> <p>Make sure the correct radio model and serial number were entered during the flash. Verify the radio's serial number entered during the flash matches what is listed on the radio screen. This can be found in the settings of the radio, listed as Device Id, Device Number, or Serial Number.</p>
The light on the Maestro is blinking RED TWICE but the radio is NOT turning on.	<p>If installing a modular radio and it is not turning on, ensure the screen is secured and any trim pieces on the radio have been installed fully. Not installing these fully will prevent radio from powering up and show a 2x red error as well.</p> <p>Test red and yellow wires for DC voltage at radio using a multimeter. Contact support if no voltage on red or yellow.</p>
The steering wheel controls are not working, the Maestro RR does not blink when they are pressed.	<p>Ensure the 20 or 28-pin connector is plugged to the vehicle and to the T01 T-harness, as shown in step 3 (this is where the RR gets the steering wheel signal from the vehicle).</p>
(Prius only) After the car is turned off, the radio stays on. The car stays in accessory mode and will not turn off.	<p>Locate the white 12-pin connector of the T01 harness, it is connected to the vehicle harness.</p> <p>Then, cut and isolate the red wire located at pin 11. The radio will shut off when the vehicle is turned off.</p>

MAESTRO RR RESET PROCEDURE:

Turn the key to the OFF position, then disconnect all connectors from the module.

Press and hold the module's programming button and connect all the connectors back to the module. Wait, the module's LED will flash RED rapidly (this may take up to 10 seconds).

Release the programming button. Wait, the LED will turn solid GREEN for 2 seconds to show the reset was successful.

TECHNICAL ASSISTANCE

Phone: 1-866-427-2999

Email: maestro.support@idatalink.com

IMPORTANT: To ensure proper operation, the aftermarket radio needs to have the latest firmware from the manufacturer. Please visit the radio manufacturer's website and look for any updates pertaining to your radio.

RETAINS STEERING WHEEL CONTROLS, FACTORY AMPLIFIER, AND MORE!



PRODUCTS REQUIRED

iDatalink Maestro RR or RR2 Radio Replacement Interface
iDatalink Maestro HRR-T01 Installation Harness

PROGRAMMED FIRMWARE

ADS-RR(SR)-TOY01-DS

ADDITIONAL RESOURCES

[Maestro RR2 Programmable Outputs Guide](#)

OPTIONAL ACCESSORIES

K40[™]
ELECTRONICS
ESCORT

Click here for:
[Radar Installation Guides](#)

HEAD UNIT ADAPTER:
ACC-HU-PI01, SON1, KEN1, KEN2, ALP1

WELCOME

Congratulations on the purchase of your iDatalink Maestro RR Radio replacement solution. You are now a few simple steps away from enjoying your new car radio with enhanced features.

Before starting your installation, please ensure that your iDatalink Maestro module is programmed with the correct firmware for your vehicle and that you carefully review the install guide.

Please note that Maestro RR will only retain functionalities that were originally available in the vehicle.

TABLE OF CONTENTS

Installation Instructions	3
Wiring Diagram	4
Radio Wire Reference Chart	5
Module Diagnostics	6
Troubleshooting Table	7

NEED HELP?

 1 866 427-2999

 maestro.support@idatalink.com

INSTALLATION INSTRUCTIONS P1/1

STEP 1

Remove the factory radio

If using head unit adapter (sold separately), connect HRR-T01 harness to adapter and skip to step 2.

- Unbox the aftermarket radio and locate its main harness.
- Cut and remove the black 20 pin connector from the HRR-T01 T-harness and connect the wires, shown in the wiring diagram, from aftermarket radio main harness to the HRR-T01 T-harness and match the wire functions.

Note: only connect purple/white wire to radio reverse input or module damage will occur.

STEP 2

- Identify if your vehicle has a 20 or 28 pin secondary connector.
- Assemble T01 T-harness as shown on wiring diagram.
- Connect the factory harness to the HRR-T01 harness.

STEP 3

- Connect HRR-T01 3-pin black connector to black connector of OBDII extension harness.
- Plug the OBDII connector into the OBDII of the vehicle.

STEP 4

- Plug the harnesses into the aftermarket radio.
- Plug the Data cable to the data port of the aftermarket radio.
- Insert the Audio cable into the iDatalink 3.5 mm audio jack of the aftermarket radio (if there is no iDatalink audio input, connect to AUX).

Note: On Pioneer radio, ensure that there is nothing plugged into the W/R port.

STEP 5

- Connect all the harnesses to the Maestro RR module then test your installation.

WIRING DIAGRAM *without an Amplifier*

STEP 1

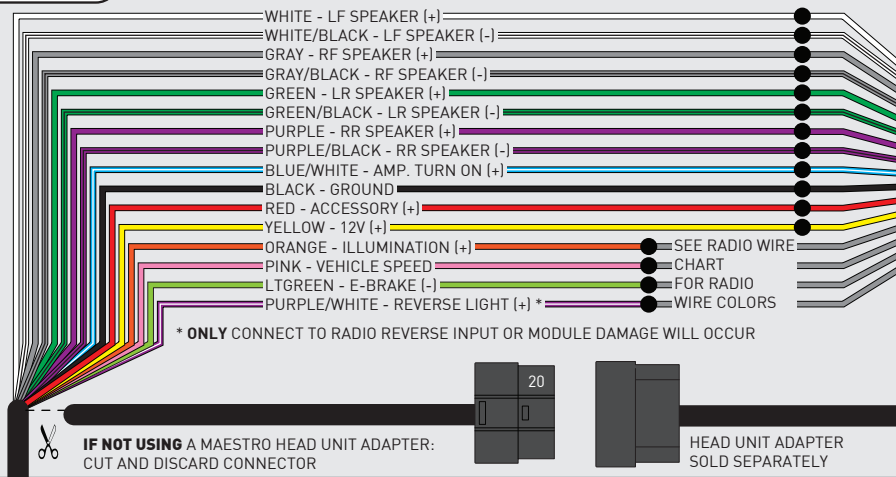

STEP 4

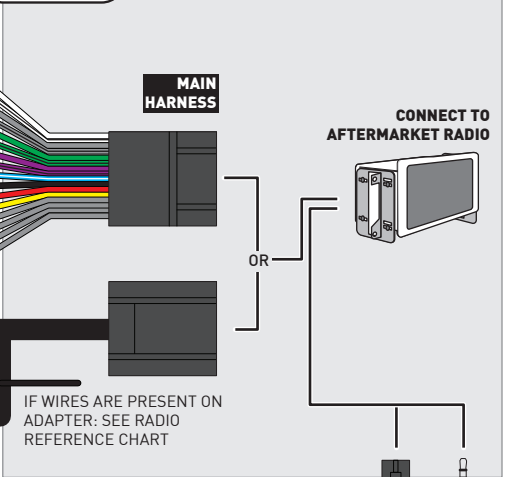

STEP 2

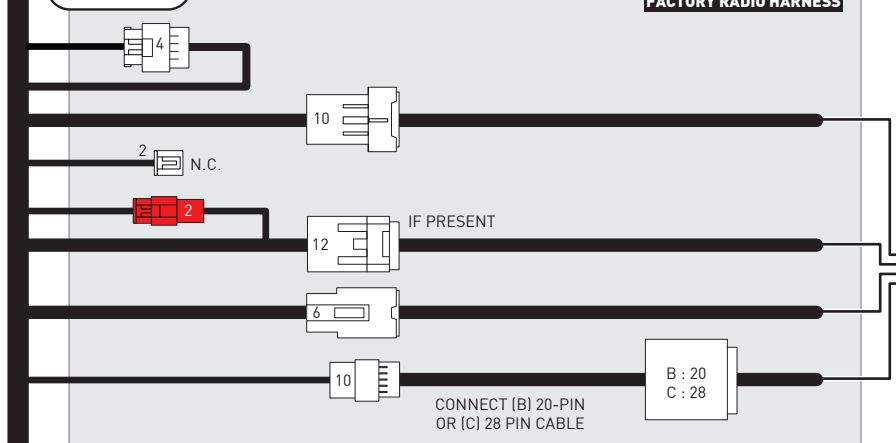

STEP 3

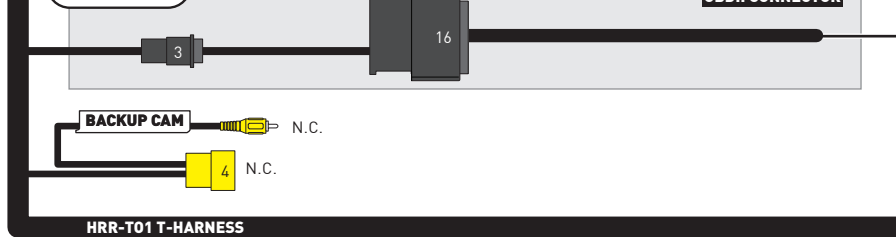

STEP 5

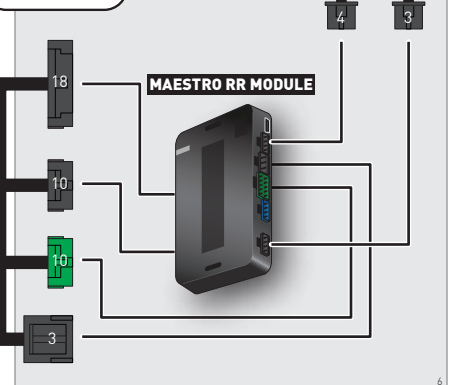

NOT REQUIRED

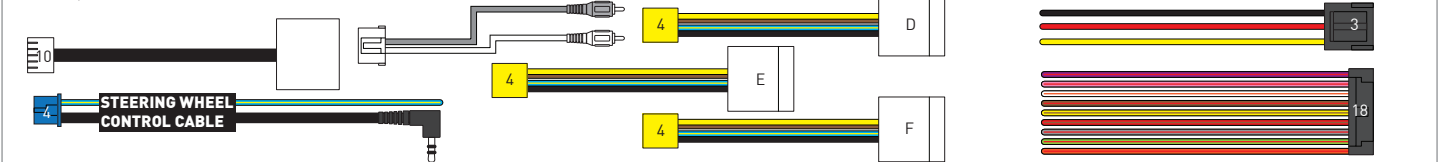

RADIO WIRE REFERENCE CHART

T01 T-harness Wire Description	Polarity	Wire Color on Maestro T-Harness	Wire Color on Alpine cable	Wire Color on Kenwood/JVC cable	Wire Color on Pioneer cable	Wire Color on Sony cable
Illumination	(+)	Orange	N/A	Orange/White	Orange/White	Orange
Reverse Light*	(+)	Purple/White	Orange/White	Purple/White	Purple/White	Purple/White
E-Brake	(-)	Lt Green	Yellow/Blue	Lt Green	Lt Green	Lt Green
VSS (vehicle speed sensor)	(DATA)	Pink	Green/White	Pink	Pink	N/A

Head unit adapter wiring (optional accessory, sold separately)

ACC-HU-ALP1 Wire Description	Polarity	Wire Color on Adapter	Alpine Radio
VSS (vehicle speed sensor)	(DATA)	Green/White	Green/White









ACC-HU-KEN1 Wire Description	Polarity	Wire Color on Adapter	Kenwood Radio
CAM	(+)	Green/Red	Refer to camera/radio manual
CAM	(-)	Green/White	Refer to camera/radio manual
Steering Wheel Controls	(DATA)	Blue/Yellow	n/a

ACC-HU-KEN2 Wire Description	Polarity	Wire Color on Adapter	Kenwood Radio
E-Brake	(-)	LtGreen	LtGreen
Reverse Light*	(+)	Purple/White	Purple/White
Steering Wheel Controls	(DATA)	Blue/Yellow	n/a

* Reverse light wire: Only connect to radio or module damage will occur.

MODULE DIAGNOSTICS



LED 1 Module/Firmware status	LED 2 (RR2) Bluetooth activity	LED STATUS	DIAGNOSTIC
 or 		RED or GREEN flashing	LED flashes 1 or more times, either red or green, when a steering wheel button is pressed : normal operation.
		1 RED flash	Module has no firmware. Flash module using Weblink Desktop and log in. Do <u>NOT</u> use DEMO MODE.
		2 RED flashes	Problem detected. Consult troubleshooting table.
		1 GREEN flash	After radio boots up : Normal operation.
		3 GREEN flashes	Bluetooth is activated. Turns off after one minute: Normal operation.
		OFF	Normal operation (inactive).

VIDEO HELP		Installation, product information, vehicle specific videos.
VERIFY FLASH		Last flash information, steering control configuration, vehicle information.
WEBLINK		Software to program module.

TROUBLESHOOTING TABLE

PROBLEM	SOLUTION
Gauges do not work, radio shows OBD2 Error 1 or Error 2.	<p>Ensure OBDII connector is securely attached to the OBDII connector of the vehicle.</p> <p>If you hardwired connections at the OBDII, check connections at the OBDII connector. Make sure the RED/BROWN wire is on PIN 6 and the YELLOW/BROWN wire is connected to PIN 14 of the OBDII connector. Do not use T-Taps. Soldering or military splicing methods are recommended.</p> <p>If anything else is connected to the OBD2 or CAN wires of vehicle (programmer, throttle controller, insurance tracker, etc.) try unplugging it to see if gauges work. If gauges work without it installed, call tech support for options.</p> <p>Reset the RR.</p>
The light on the Maestro is blinking RED TWICE and the radio IS turning on.	<p>Ensure the 4-pin data cable is connected between the radio and the RR, and that it is plugged into the black port on the Maestro RR. The red and blue ports on the RR should be empty.</p> <p>Make sure the correct radio model and serial number were entered during the flash. Verify the radio's serial number entered during the flash matches what is listed on the radio screen. This can be found in the settings of the radio, listed as Device Id, Device Number, or Serial Number.</p>
The light on the Maestro is blinking RED TWICE but the radio is NOT turning on.	<p>If installing a modular radio and it is not turning on, ensure the screen is secured and any trim pieces on the radio have been installed fully. Not installing these fully will prevent radio from powering up and show a 2x red error as well.</p> <p>Test red and yellow wires for DC voltage at radio using a multimeter. Contact support if no voltage on red or yellow.</p>
The steering wheel controls are not working, the Maestro RR does not blink when they are pressed.	<p>Ensure the 20 or 28-pin connector is plugged to the vehicle and to the T01 T-harness, as shown in step 3 (this is where the RR gets the steering wheel signal from the vehicle).</p>
(Prius only) After the car is turned off, the radio stays on. The car stays in accessory mode and will not turn off.	<p>Locate the white 12-pin connector of the T01 harness, it is connected to the vehicle harness.</p> <p>Then, cut and isolate the red wire located at pin 11. The radio will shut off when the vehicle is turned off.</p>

MAESTRO RR RESET PROCEDURE:

Turn the key to the OFF position, then disconnect all connectors from the module.

Press and hold the module's programming button and connect all the connectors back to the module. Wait, the module's LED will flash RED rapidly (this may take up to 10 seconds).

Release the programming button. Wait, the LED will turn solid GREEN for 2 seconds to show the reset was successful.

TECHNICAL ASSISTANCE

Phone: 1-866-427-2999

Email: maestro.support@idatalink.com

IMPORTANT: To ensure proper operation, the aftermarket radio needs to have the latest firmware from the manufacturer. Please visit the radio manufacturer's website and look for any updates pertaining to your radio.

RETAINS STEERING WHEEL CONTROLS, FACTORY AMPLIFIER, AND MORE!



PRODUCTS REQUIRED

iDatalink Maestro RR or RR2 Radio Replacement Interface
iDatalink Maestro HRR-T01 Installation Harness

PROGRAMMED FIRMWARE

ADS-RR(SR)-TOY01-DS

ADDITIONAL RESOURCES

[Maestro RR2 Programmable Outputs Guide](#)

OPTIONAL ACCESSORIES

K40[™]
ELECTRONICS
ESCORT

Click here for:
[Radar Installation Guides](#)

HEAD UNIT ADAPTER:
ACC-HU-PI01, SON1, KEN1, KEN2, ALP1

WELCOME

Congratulations on the purchase of your iDatalink Maestro RR Radio replacement solution. You are now a few simple steps away from enjoying your new car radio with enhanced features.

Before starting your installation, please ensure that your iDatalink Maestro module is programmed with the correct firmware for your vehicle and that you carefully review the install guide.

Please note that Maestro RR will only retain functionalities that were originally available in the vehicle.

TABLE OF CONTENTS

Installation Instructions	3
Wiring Diagram	4
Radio Wire Reference Chart	5
Module Diagnostics	6
Troubleshooting Table	7

NEED HELP?

 1 866 427-2999

 maestro.support@idatalink.com

INSTALLATION INSTRUCTIONS P1/1

STEP 1

Remove the factory radio

If using head unit adapter (sold separately), connect HRR-T01 harness to adapter and skip to step 2.

- Unbox the aftermarket radio and locate its main harness.
- Cut and remove the black 20 pin connector from the HRR-T01 T-harness and connect the wires, shown in the wiring diagram, from aftermarket radio main harness to the HRR-T01 T-harness and match the wire functions.

Note: only connect purple/white wire to radio reverse input or module damage will occur.

STEP 2

- If the vehicle is equipped with an OEM backup camera, connect the HRR-T01 harness to appropriate HRR adapter cable (D, E or F) then connect to the backup camera harness.

STEP 3

- Identify if your vehicle has a 20 or 28 pin secondary connector.
- Assemble T01 T-harness as shown on wiring diagram.
- Connect the factory harness to the HRR-T01 harness.

STEP 4

- Connect HRR-T01 3-pin black connector to black connector of OBDII extension harness.
- Plug the OBDII connector into the OBDII of the vehicle.

STEP 5

- Plug the harnesses into the aftermarket radio.
- Connect the backup camera RCA cable into the aftermarket radio (if equipped).
- Connect the left front and right front low level outputs RCA cables into the aftermarket radio.
- Plug the Data cable to the data port of the aftermarket radio.
- Insert the Audio cable into the iDatalink 3.5 mm audio jack of the aftermarket radio (if there is no iDatalink audio input, connect to AUX).

Note: On Pioneer radio, ensure that there is nothing plugged into the W/R port.

STEP 6

- Connect all the harnesses to the Maestro RR module then test your installation.

WIRING DIAGRAM *with an Amplifier*

STEP 1

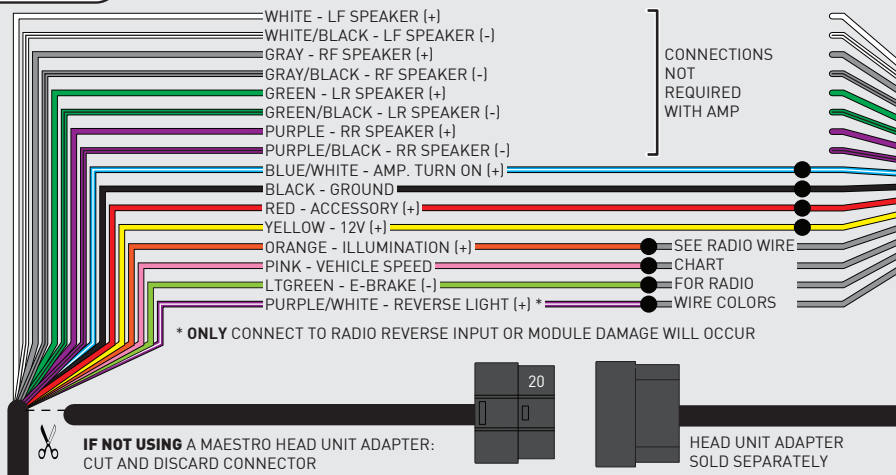

STEP 5

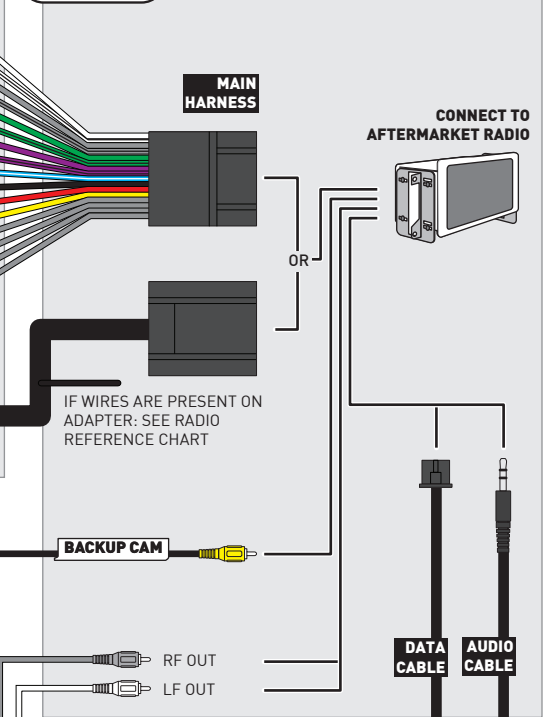

STEP 2

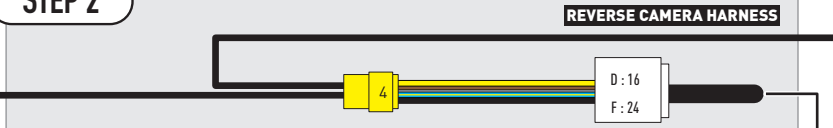

STEP 3

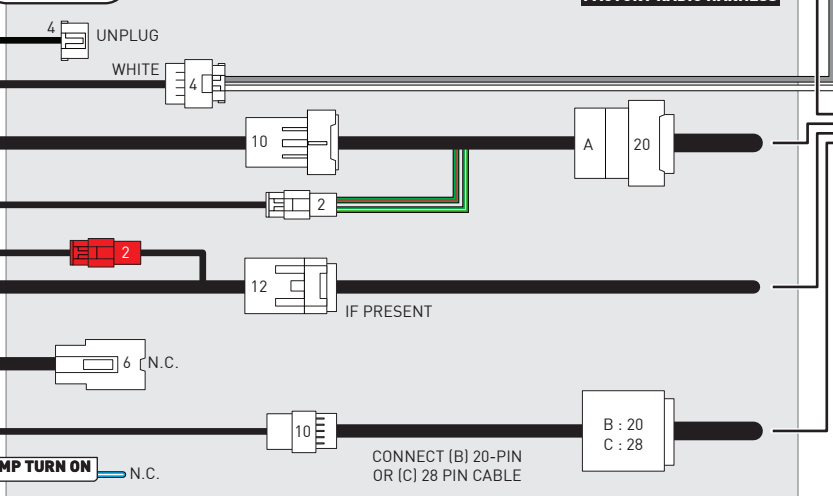

STEP 4

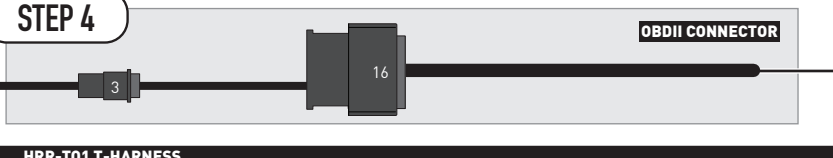

STEP 6

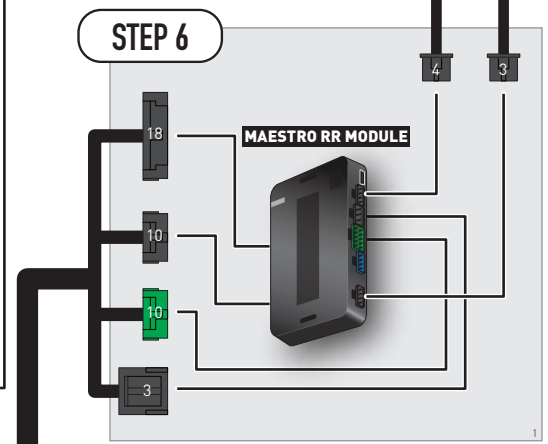

NOT REQUIRED

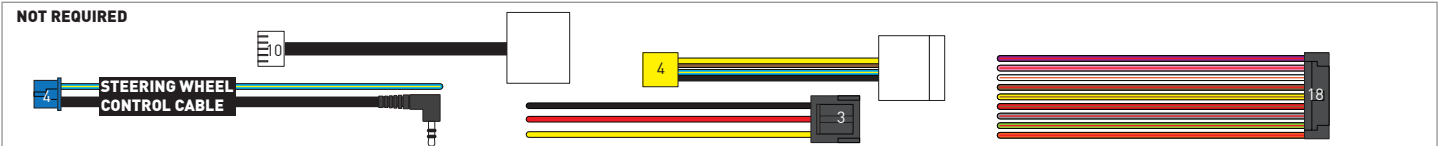

RADIO WIRE REFERENCE CHART

T01 T-harness Wire Description	Polarity	Wire Color on Maestro T-Harness	Wire Color on Alpine cable	Wire Color on Kenwood/JVC cable	Wire Color on Pioneer cable	Wire Color on Sony cable
Illumination	(+)	Orange	N/A	Orange/White	Orange/White	Orange
Reverse Light*	(+)	Purple/White	Orange/White	Purple/White	Purple/White	Purple/White
E-Brake	(-)	Lt Green	Yellow/Blue	Lt Green	Lt Green	Lt Green
VSS (vehicle speed sensor)	(DATA)	Pink	Green/White	Pink	Pink	N/A

Head unit adapter wiring (optional accessory, sold separately)

ACC-HU-ALP1 Wire Description	Polarity	Wire Color on Adapter	Alpine Radio
VSS (vehicle speed sensor)	(DATA)	Green/White	Green/White

ACC-HU-KEN1 Wire Description	Polarity	Wire Color on Adapter	Kenwood Radio
CAM	(+)	Green/Red	Refer to camera/radio manual
CAM	(-)	Green/White	Refer to camera/radio manual
Steering Wheel Controls	(DATA)	Blue/Yellow	n/a

ACC-HU-KEN2 Wire Description	Polarity	Wire Color on Adapter	Kenwood Radio
E-Brake	(-)	LtGreen	LtGreen
Reverse Light*	(+)	Purple/White	Purple/White
Steering Wheel Controls	(DATA)	Blue/Yellow	n/a

* Reverse light wire: Only connect to radio or module damage will occur.

MODULE DIAGNOSTICS



LED 1 Module/Firmware status	LED 2 (RR2) Bluetooth activity	LED STATUS	DIAGNOSTIC
or		RED or GREEN flashing	LED flashes 1 or more times, either red or green, when a steering wheel button is pressed : normal operation.
		1 RED flash	Module has no firmware. Flash module using Weblink Desktop and log in. Do <u>NOT</u> use DEMO MODE.
		2 RED flashes	Problem detected. Consult troubleshooting table.
		1 GREEN flash	After radio boots up : Normal operation.
		3 GREEN flashes	Bluetooth is activated. Turns off after one minute: Normal operation.
		OFF	Normal operation (inactive).

VIDEO HELP		Installation, product information, vehicle specific videos.
VERIFY FLASH		Last flash information, steering control configuration, vehicle information.
WEBLINK		Software to program module.

TROUBLESHOOTING TABLE

PROBLEM	SOLUTION
Gauges do not work, radio shows OBD2 Error 1 or Error 2.	<p>Ensure OBDII connector is securely attached to the OBDII connector of the vehicle.</p> <p>If you hardwired connections at the OBDII, check connections at the OBDII connector. Make sure the RED/BROWN wire is on PIN 6 and the YELLOW/BROWN wire is connected to PIN 14 of the OBDII connector. Do not use T-Taps. Soldering or military splicing methods are recommended.</p> <p>If anything else is connected to the OBD2 or CAN wires of vehicle (programmer, throttle controller, insurance tracker, etc.) try unplugging it to see if gauges work. If gauges work without it installed, call tech support for options.</p> <p>Reset the RR.</p>
The light on the Maestro is blinking RED TWICE and the radio IS turning on.	<p>Ensure the 4-pin data cable is connected between the radio and the RR, and that it is plugged into the black port on the Maestro RR. The red and blue ports on the RR should be empty.</p> <p>Make sure the correct radio model and serial number were entered during the flash. Verify the radio's serial number entered during the flash matches what is listed on the radio screen. This can be found in the settings of the radio, listed as Device Id, Device Number, or Serial Number.</p>
The light on the Maestro is blinking RED TWICE but the radio is NOT turning on.	<p>If installing a modular radio and it is not turning on, ensure the screen is secured and any trim pieces on the radio have been installed fully. Not installing these fully will prevent radio from powering up and show a 2x red error as well.</p> <p>Test red and yellow wires for DC voltage at radio using a multimeter. Contact support if no voltage on red or yellow.</p>
The steering wheel controls are not working, the Maestro RR does not blink when they are pressed.	<p>Ensure the 20 or 28-pin connector is plugged to the vehicle and to the T01 T-harness, as shown in step 3 (this is where the RR gets the steering wheel signal from the vehicle).</p>
(Prius only) After the car is turned off, the radio stays on. The car stays in accessory mode and will not turn off.	<p>Locate the white 12-pin connector of the T01 harness, it is connected to the vehicle harness.</p> <p>Then, cut and isolate the red wire located at pin 11. The radio will shut off when the vehicle is turned off.</p>

MAESTRO RR RESET PROCEDURE:

Turn the key to the OFF position, then disconnect all connectors from the module.

Press and hold the module's programming button and connect all the connectors back to the module. Wait, the module's LED will flash RED rapidly (this may take up to 10 seconds).

Release the programming button. Wait, the LED will turn solid GREEN for 2 seconds to show the reset was successful.

TECHNICAL ASSISTANCE

Phone: 1-866-427-2999

Email: maestro.support@idatalink.com

IMPORTANT: To ensure proper operation, the aftermarket radio needs to have the latest firmware from the manufacturer. Please visit the radio manufacturer's website and look for any updates pertaining to your radio.

RETAINS STEERING WHEEL CONTROLS, FACTORY AMPLIFIER, AND MORE!



PRODUCTS REQUIRED

iDatalink Maestro RR or RR2 Radio Replacement Interface
iDatalink Maestro HRR-T01 Installation Harness

PROGRAMMED FIRMWARE

ADS-RR(SR)-TOY01-DS

ADDITIONAL RESOURCES

[Maestro RR2 Programmable Outputs Guide](#)

OPTIONAL ACCESSORIES

K40[™]
ELECTRONICS
ESCORT

Click here for:
[Radar Installation Guides](#)

HEAD UNIT ADAPTER:
ACC-HU-PI01, SON1, KEN1, KEN2, ALP1

WELCOME

Congratulations on the purchase of your iDatalink Maestro RR Radio replacement solution. You are now a few simple steps away from enjoying your new car radio with enhanced features.

Before starting your installation, please ensure that your iDatalink Maestro module is programmed with the correct firmware for your vehicle and that you carefully review the install guide.

Please note that Maestro RR will only retain functionalities that were originally available in the vehicle.

TABLE OF CONTENTS

Installation Instructions	3
Wiring Diagram	4
Radio Wire Reference Chart	5
Module Diagnostics	6
Troubleshooting Table	7

NEED HELP?

 1 866 427-2999

 maestro.support@idatalink.com

INSTALLATION INSTRUCTIONS P1/1

STEP 1

Remove the factory radio

If using head unit adapter (sold separately), connect HRR-T01 harness to adapter and skip to step 2.

- Unbox the aftermarket radio and locate its main harness.
- Cut and remove the black 20 pin connector from the HRR-T01 T-harness and connect the wires, shown in the wiring diagram, from aftermarket radio main harness to the HRR-T01 T-harness and match the wire functions.

Note: only connect purple/white wire to radio reverse input or module damage will occur.

STEP 2

- If the vehicle is equipped with an OEM backup camera, connect the HRR-T01 harness to any HRR adapter cable (D, E or F) then cut off the 16 or 24-pin connector. Connect the adapter's wires to reverse camera harness, as shown in wiring diagram.
- Assemble T01 T-harness as shown on wiring diagram.
- Connect the factory harness to the HRR-T01 harness.

STEP 3

- Connect HRR-T01 3-pin black connector to black connector of OBDII extension harness.
- Plug the OBDII connector into the OBDII of the vehicle.

STEP 4

- Plug the harnesses into the aftermarket radio.
- Connect the backup camera RCA cable into the aftermarket radio (if equipped).
- Plug the Data cable to the data port of the aftermarket radio.
- Insert the Audio cable into the iDatalink 3.5 mm audio jack of the aftermarket radio (if there is no iDatalink audio input, connect to AUX).

Note: On Pioneer radio, ensure that there is nothing plugged into the W/R port.

STEP 5

- Connect all the harnesses to the Maestro RR module then test your installation.

WIRING DIAGRAM *without an Amplifier*

STEP 1

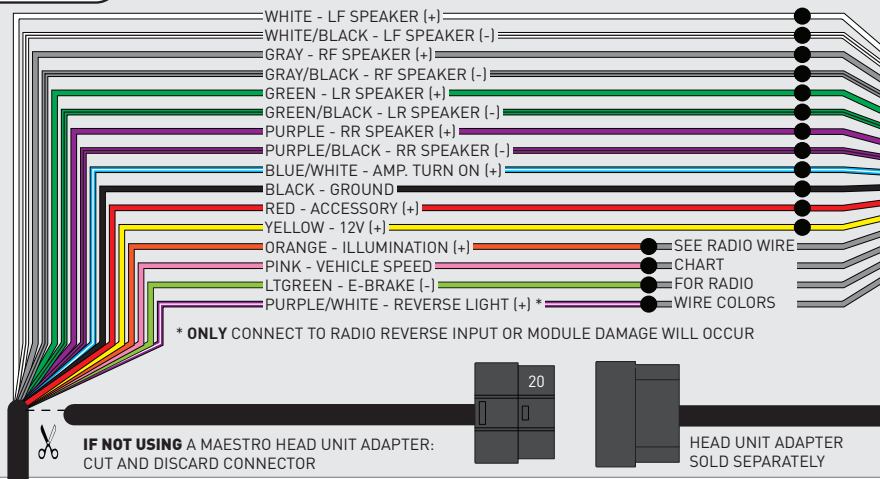

STEP 4

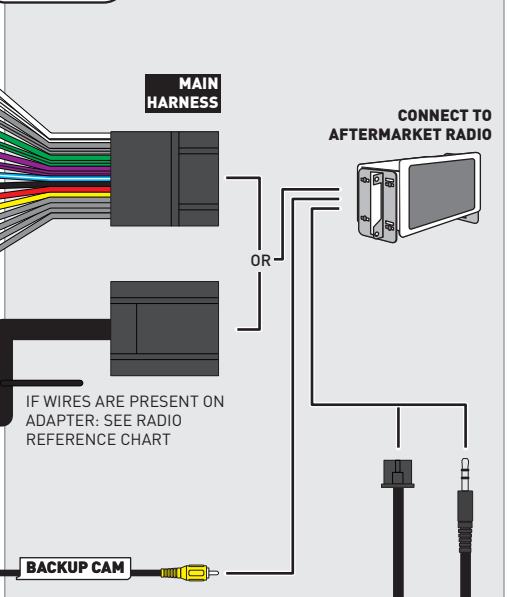

STEP 2

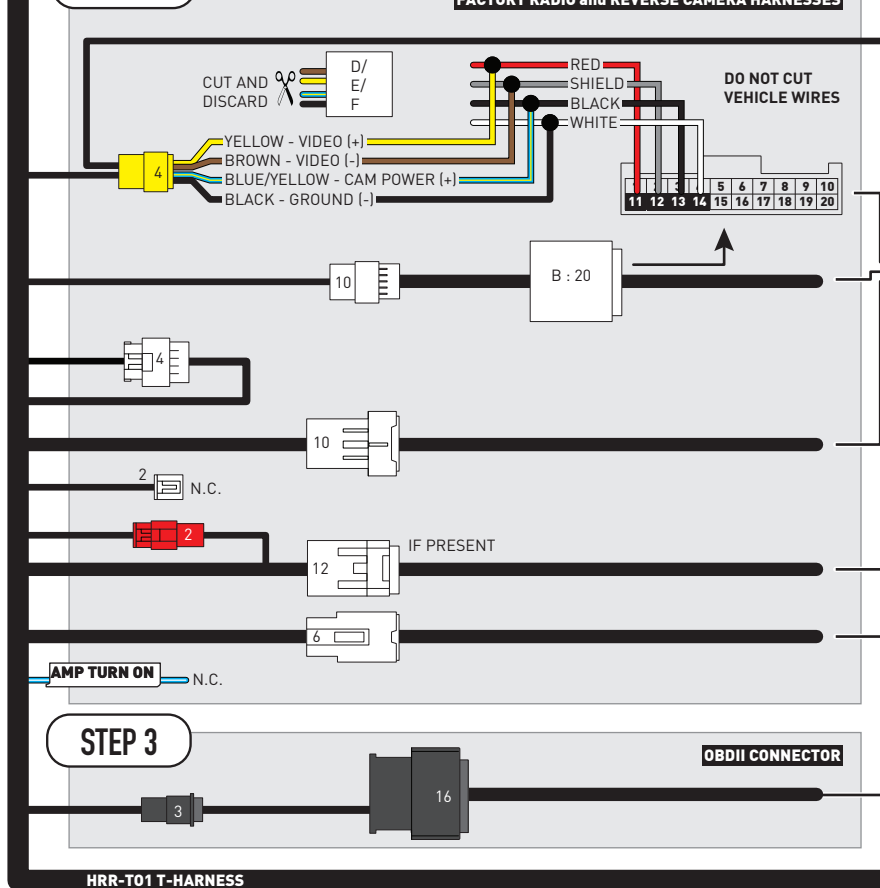

STEP 5

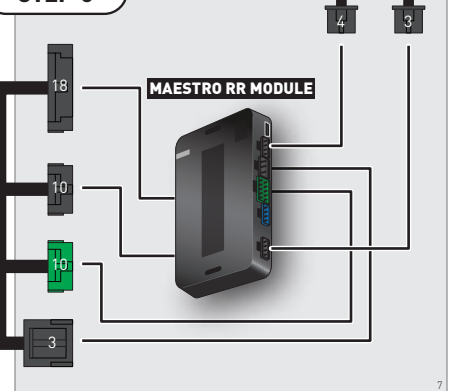

NOT REQUIRED

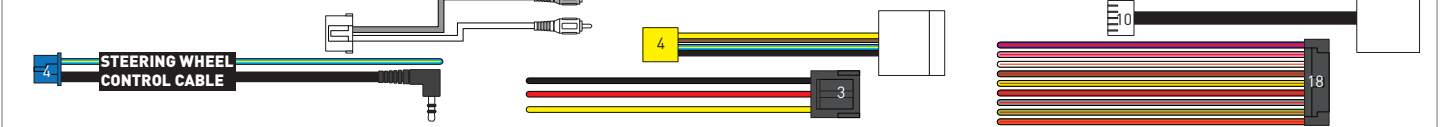

RADIO WIRE REFERENCE CHART

T01 T-harness Wire Description	Polarity	Wire Color on Maestro T-Harness	Wire Color on Alpine cable	Wire Color on Kenwood/JVC cable	Wire Color on Pioneer cable	Wire Color on Sony cable
Illumination	(+)	Orange	N/A	Orange/White	Orange/White	Orange
Reverse Light*	(+)	Purple/White	Orange/White	Purple/White	Purple/White	Purple/White
E-Brake	(-)	Lt Green	Yellow/Blue	Lt Green	Lt Green	Lt Green
VSS (vehicle speed sensor)	(DATA)	Pink	Green/White	Pink	Pink	N/A

Head unit adapter wiring (optional accessory, sold separately)

ACC-HU-ALP1 Wire Description	Polarity	Wire Color on Adapter	Alpine Radio
VSS (vehicle speed sensor)	(DATA)	Green/White	Green/White

ACC-HU-KEN1 Wire Description	Polarity	Wire Color on Adapter	Kenwood Radio
CAM	(+)	Green/Red	Refer to camera/radio manual
CAM	(-)	Green/White	Refer to camera/radio manual
Steering Wheel Controls	(DATA)	Blue/Yellow	n/a

ACC-HU-KEN2 Wire Description	Polarity	Wire Color on Adapter	Kenwood Radio
E-Brake	(-)	LtGreen	LtGreen
Reverse Light*	(+)	Purple/White	Purple/White
Steering Wheel Controls	(DATA)	Blue/Yellow	n/a

* Reverse light wire: Only connect to radio or module damage will occur.

MODULE DIAGNOSTICS



LED 1 Module/Firmware status	LED 2 (RR2) Bluetooth activity	LED STATUS	DIAGNOSTIC
or		RED or GREEN flashing	LED flashes 1 or more times, either red or green, when a steering wheel button is pressed : normal operation.
		1 RED flash	Module has no firmware. Flash module using Weblink Desktop and log in. Do <u>NOT</u> use DEMO MODE.
		2 RED flashes	Problem detected. Consult troubleshooting table.
		1 GREEN flash	After radio boots up : Normal operation.
		3 GREEN flashes	Bluetooth is activated. Turns off after one minute: Normal operation.
		OFF	Normal operation (inactive).

VIDEO HELP		Installation, product information, vehicle specific videos.
VERIFY FLASH		Last flash information, steering control configuration, vehicle information.
WEBLINK		Software to program module.

TROUBLESHOOTING TABLE

PROBLEM	SOLUTION
Gauges do not work, radio shows OBD2 Error 1 or Error 2.	<p>Ensure OBDII connector is securely attached to the OBDII connector of the vehicle.</p> <p>If you hardwired connections at the OBDII, check connections at the OBDII connector. Make sure the RED/BROWN wire is on PIN 6 and the YELLOW/BROWN wire is connected to PIN 14 of the OBDII connector. Do not use T-Taps. Soldering or military splicing methods are recommended.</p> <p>If anything else is connected to the OBD2 or CAN wires of vehicle (programmer, throttle controller, insurance tracker, etc.) try unplugging it to see if gauges work. If gauges work without it installed, call tech support for options.</p> <p>Reset the RR.</p>
The light on the Maestro is blinking RED TWICE and the radio IS turning on.	<p>Ensure the 4-pin data cable is connected between the radio and the RR, and that it is plugged into the black port on the Maestro RR. The red and blue ports on the RR should be empty.</p> <p>Make sure the correct radio model and serial number were entered during the flash. Verify the radio's serial number entered during the flash matches what is listed on the radio screen. This can be found in the settings of the radio, listed as Device Id, Device Number, or Serial Number.</p>
The light on the Maestro is blinking RED TWICE but the radio is NOT turning on.	<p>If installing a modular radio and it is not turning on, ensure the screen is secured and any trim pieces on the radio have been installed fully. Not installing these fully will prevent radio from powering up and show a 2x red error as well.</p> <p>Test red and yellow wires for DC voltage at radio using a multimeter. Contact support if no voltage on red or yellow.</p>
The steering wheel controls are not working, the Maestro RR does not blink when they are pressed.	<p>Ensure the 20 or 28-pin connector is plugged to the vehicle and to the T01 T-harness, as shown in step 3 (this is where the RR gets the steering wheel signal from the vehicle).</p>
(Prius only) After the car is turned off, the radio stays on. The car stays in accessory mode and will not turn off.	<p>Locate the white 12-pin connector of the T01 harness, it is connected to the vehicle harness.</p> <p>Then, cut and isolate the red wire located at pin 11. The radio will shut off when the vehicle is turned off.</p>

MAESTRO RR RESET PROCEDURE:

Turn the key to the OFF position, then disconnect all connectors from the module.

Press and hold the module's programming button and connect all the connectors back to the module. Wait, the module's LED will flash RED rapidly (this may take up to 10 seconds).

Release the programming button. Wait, the LED will turn solid GREEN for 2 seconds to show the reset was successful.

TECHNICAL ASSISTANCE

Phone: 1-866-427-2999

Email: maestro.support@idatalink.com

IMPORTANT: To ensure proper operation, the aftermarket radio needs to have the latest firmware from the manufacturer. Please visit the radio manufacturer's website and look for any updates pertaining to your radio.

RETAINS STEERING WHEEL CONTROLS, FACTORY AMPLIFIER, AND MORE!



PRODUCTS REQUIRED

iDatalink Maestro RR or RR2 Radio Replacement Interface
iDatalink Maestro HRR-T01 Installation Harness

PROGRAMMED FIRMWARE

ADS-RR(SR)-TOY01-DS

ADDITIONAL RESOURCES

[Maestro RR2 Programmable Outputs Guide](#)

OPTIONAL ACCESSORIES

K40[™]
ELECTRONICS
ESCORT

Click here for:
[Radar Installation Guides](#)

HEAD UNIT ADAPTER:
ACC-HU-PI01, SON1, KEN1, KEN2, ALP1

WELCOME

Congratulations on the purchase of your iDatalink Maestro RR Radio replacement solution. You are now a few simple steps away from enjoying your new car radio with enhanced features.

Before starting your installation, please ensure that your iDatalink Maestro module is programmed with the correct firmware for your vehicle and that you carefully review the install guide.

Please note that Maestro RR will only retain functionalities that were originally available in the vehicle.

TABLE OF CONTENTS

Installation Instructions	3
Wiring Diagram	4
Radio Wire Reference Chart	5
Module Diagnostics	6
Troubleshooting Table	7

NEED HELP?

 1 866 427-2999

 maestro.support@idatalink.com

INSTALLATION INSTRUCTIONS P1/1

STEP 1

Remove the factory radio

If using head unit adapter (sold separately), connect HRR-T01 harness to adapter and skip to step 2.

- Unbox the aftermarket radio and locate its main harness.
- Cut and remove the black 20 pin connector from the HRR-T01 T-harness and connect the wires, shown in the wiring diagram, from aftermarket radio main harness to the HRR-T01 T-harness and match the wire functions.

Note: only connect purple/white wire to radio reverse input or module damage will occur.

STEP 2

- If the vehicle is equipped with an OEM backup camera, connect the HRR-T01 harness to appropriate HRR adapter cable (D, E or F) then connect to the backup camera harness.

STEP 3

- Identify if your vehicle has a 20 or 28 pin secondary connector.
- Assemble T01 T-harness as shown on wiring diagram.
- Connect the factory harness to the HRR-T01 harness.

STEP 4

- Connect HRR-T01 3-pin black connector to black connector of OBDII extension harness.
- Plug the OBDII connector into the OBDII of the vehicle.

STEP 5

- Plug the harnesses into the aftermarket radio.
- Connect the backup camera RCA cable into the aftermarket radio (if equipped).
- Plug the Data cable to the data port of the aftermarket radio.
- Insert the Audio cable into the iDatalink 3.5 mm audio jack of the aftermarket radio (if there is no iDatalink audio input, connect to AUX).

Note: On Pioneer radio, ensure that there is nothing plugged into the W/R port.

STEP 6

- Connect all the harnesses to the Maestro RR module then test your installation.

WIRING DIAGRAM *without an Amplifier*

STEP 1

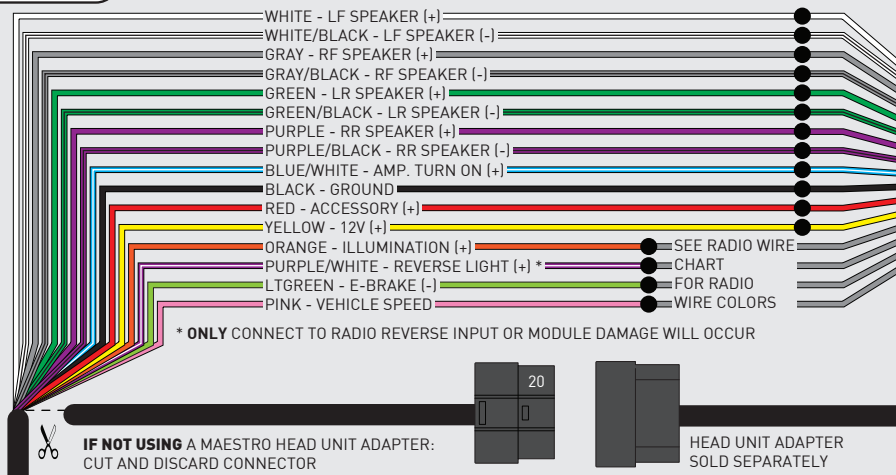

STEP 5

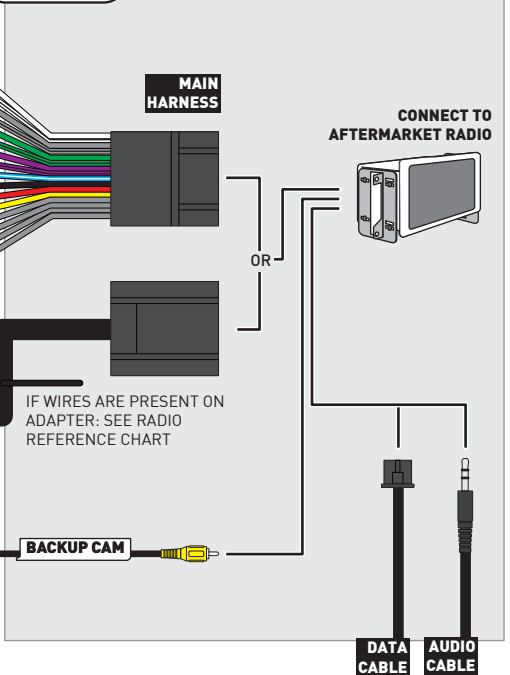

STEP 2

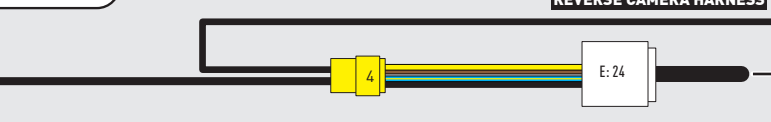

STEP 3

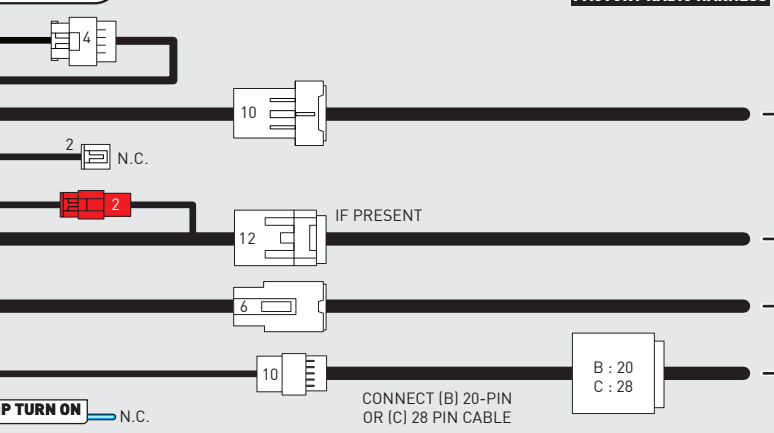

STEP 4



STEP 6

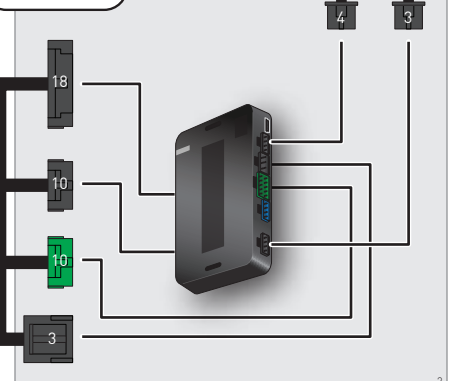

NOT REQUIRED

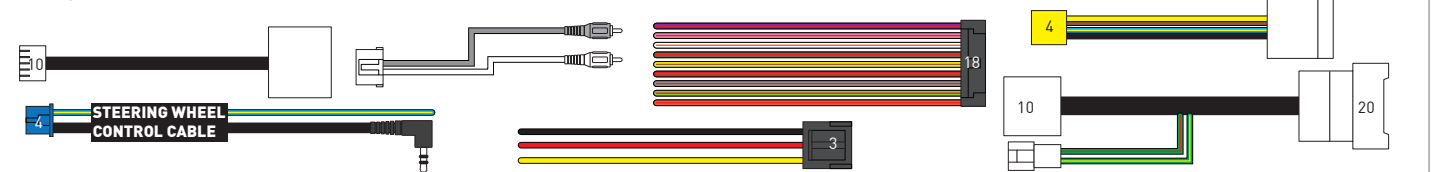

RADIO WIRE REFERENCE CHART

T01 T-harness Wire Description	Polarity	Wire Color on Maestro T-Harness	Wire Color on Alpine cable	Wire Color on Kenwood/JVC cable	Wire Color on Pioneer cable	Wire Color on Sony cable
Illumination	(+)	Orange	N/A	Orange/White	Orange/White	Orange
Reverse Light*	(+)	Purple/White	Orange/White	Purple/White	Purple/White	Purple/White
E-Brake	(-)	Lt Green	Yellow/Blue	Lt Green	Lt Green	Lt Green
VSS (vehicle speed sensor)	(DATA)	Pink	Green/White	Pink	Pink	N/A

Head unit adapter wiring (optional accessory, sold separately)

ACC-HU-ALP1 Wire Description	Polarity	Wire Color on Adapter	Alpine Radio
VSS (vehicle speed sensor)	(DATA)	Green/White	Green/White









ACC-HU-KEN1 Wire Description	Polarity	Wire Color on Adapter	Kenwood Radio
CAM	(+)	Green/Red	Refer to camera/radio manual
CAM	(-)	Green/White	Refer to camera/radio manual
Steering Wheel Controls	(DATA)	Blue/Yellow	n/a

ACC-HU-KEN2 Wire Description	Polarity	Wire Color on Adapter	Kenwood Radio
E-Brake	(-)	LtGreen	LtGreen
Reverse Light*	(+)	Purple/White	Purple/White
Steering Wheel Controls	(DATA)	Blue/Yellow	n/a

* Reverse light wire: Only connect to radio or module damage will occur.

MODULE DIAGNOSTICS



LED 1 Module/Firmware status	LED 2 (RR2) Bluetooth activity	LED STATUS	DIAGNOSTIC
 or 		RED or GREEN flashing	LED flashes 1 or more times, either red or green, when a steering wheel button is pressed : normal operation.
		1 RED flash	Module has no firmware. Flash module using Weblink Desktop and log in. Do <u>NOT</u> use DEMO MODE.
		2 RED flashes	Problem detected. Consult troubleshooting table.
		1 GREEN flash	After radio boots up : Normal operation.
		3 GREEN flashes	Bluetooth is activated. Turns off after one minute: Normal operation.
		OFF	Normal operation (inactive).

VIDEO HELP		Installation, product information, vehicle specific videos.
VERIFY FLASH		Last flash information, steering control configuration, vehicle information.
WEBLINK		Software to program module.

TROUBLESHOOTING TABLE

PROBLEM	SOLUTION
Gauges do not work, radio shows OBD2 Error 1 or Error 2.	<p>Ensure OBDII connector is securely attached to the OBDII connector of the vehicle.</p> <p>If you hardwired connections at the OBDII, check connections at the OBDII connector. Make sure the RED/BROWN wire is on PIN 6 and the YELLOW/BROWN wire is connected to PIN 14 of the OBDII connector. Do not use T-Taps. Soldering or military splicing methods are recommended.</p> <p>If anything else is connected to the OBD2 or CAN wires of vehicle (programmer, throttle controller, insurance tracker, etc.) try unplugging it to see if gauges work. If gauges work without it installed, call tech support for options.</p> <p>Reset the RR.</p>
The light on the Maestro is blinking RED TWICE and the radio IS turning on.	<p>Ensure the 4-pin data cable is connected between the radio and the RR, and that it is plugged into the black port on the Maestro RR. The red and blue ports on the RR should be empty.</p> <p>Make sure the correct radio model and serial number were entered during the flash. Verify the radio's serial number entered during the flash matches what is listed on the radio screen. This can be found in the settings of the radio, listed as Device Id, Device Number, or Serial Number.</p>
The light on the Maestro is blinking RED TWICE but the radio is NOT turning on.	<p>If installing a modular radio and it is not turning on, ensure the screen is secured and any trim pieces on the radio have been installed fully. Not installing these fully will prevent radio from powering up and show a 2x red error as well.</p> <p>Test red and yellow wires for DC voltage at radio using a multimeter. Contact support if no voltage on red or yellow.</p>
The steering wheel controls are not working, the Maestro RR does not blink when they are pressed.	<p>Ensure the 20 or 28-pin connector is plugged to the vehicle and to the T01 T-harness, as shown in step 3 (this is where the RR gets the steering wheel signal from the vehicle).</p>
(Prius only) After the car is turned off, the radio stays on. The car stays in accessory mode and will not turn off.	<p>Locate the white 12-pin connector of the T01 harness, it is connected to the vehicle harness.</p> <p>Then, cut and isolate the red wire located at pin 11. The radio will shut off when the vehicle is turned off.</p>

MAESTRO RR RESET PROCEDURE:

Turn the key to the OFF position, then disconnect all connectors from the module.

Press and hold the module's programming button and connect all the connectors back to the module. Wait, the module's LED will flash RED rapidly (this may take up to 10 seconds).

Release the programming button. Wait, the LED will turn solid GREEN for 2 seconds to show the reset was successful.

TECHNICAL ASSISTANCE

Phone: 1-866-427-2999

Email: maestro.support@idatalink.com

IMPORTANT: To ensure proper operation, the aftermarket radio needs to have the latest firmware from the manufacturer. Please visit the radio manufacturer's website and look for any updates pertaining to your radio.

RETAINS STEERING WHEEL CONTROLS, FACTORY AMPLIFIER, AND MORE!



PRODUCTS REQUIRED

iDatalink Maestro RR or RR2 Radio Replacement Interface
iDatalink Maestro HRR-T01 Installation Harness

PROGRAMMED FIRMWARE

ADS-RR(SR)-TOY01-DS

ADDITIONAL RESOURCES

[Maestro RR2 Programmable Outputs Guide](#)

OPTIONAL ACCESSORIES

K40
ELECTRONICS
ESCORT

Click here for:
[Radar Installation Guides](#)

HEAD UNIT ADAPTER:
ACC-HU-PI01, SON1, KEN1, KEN2, ALP1

WELCOME

Congratulations on the purchase of your iDatalink Maestro RR Radio replacement solution. You are now a few simple steps away from enjoying your new car radio with enhanced features.

Before starting your installation, please ensure that your iDatalink Maestro module is programmed with the correct firmware for your vehicle and that you carefully review the install guide.

Please note that Maestro RR will only retain functionalities that were originally available in the vehicle.

TABLE OF CONTENTS

Installation Instructions	3
Wiring Diagram	4
Radio Wire Reference Chart	5
Module Diagnostics	6
Troubleshooting Table	7

NEED HELP?

 1 866 427-2999

 maestro.support@idatalink.com

INSTALLATION INSTRUCTIONS P1/1

STEP 1

Remove the factory radio

If using head unit adapter (sold separately), connect HRR-T01 harness to adapter and skip to step 2.

- Unbox the aftermarket radio and locate its main harness.
- Cut and remove the black 20 pin connector from the HRR-T01 T-harness and connect the wires, shown in the wiring diagram, from aftermarket radio main harness to the HRR-T01 T-harness and match the wire functions.

Note: only connect purple/white wire to radio reverse input or module damage will occur.

STEP 2

- If the vehicle is equipped with an OEM backup camera, connect the HRR-T01 harness to appropriate HRR adapter cable (D, E or F) then connect to the backup camera harness.

STEP 3

- Identify if your vehicle has a 20 or 28 pin secondary connector.
- Assemble T01 T-harness as shown on wiring diagram.
- Connect the factory harness to the HRR-T01 harness.

STEP 4

- Connect HRR-T01 3-pin black connector to black connector of OBDII extension harness.
- Plug the OBDII connector into the OBDII of the vehicle.

STEP 5

- Plug the harnesses into the aftermarket radio.
- Connect the backup camera RCA cable into the aftermarket radio (if equipped).
- Connect the left front and right front low level outputs RCA cables into the aftermarket radio.
- Plug the Data cable to the data port of the aftermarket radio.
- Insert the Audio cable into the iDatalink 3.5 mm audio jack of the aftermarket radio (if there is no iDatalink audio input, connect to AUX).

Note: On Pioneer radio, ensure that there is nothing plugged into the W/R port.

STEP 6

- Connect all the harnesses to the Maestro RR module then test your installation.

WIRING DIAGRAM *with an Amplifier*

STEP 1

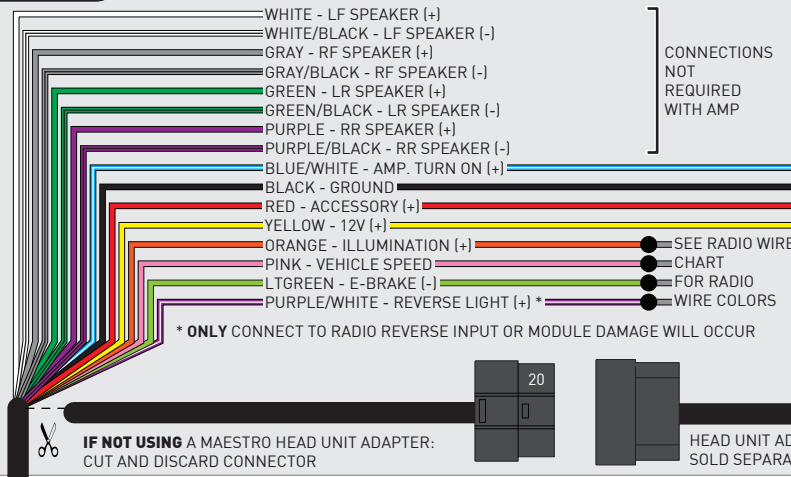

STEP 5

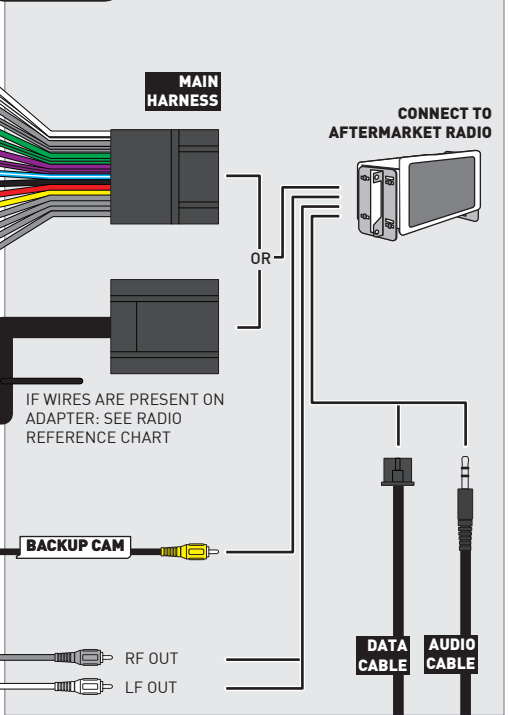

STEP 2

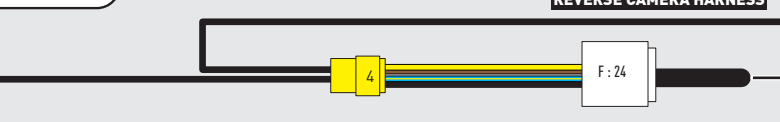

STEP 3

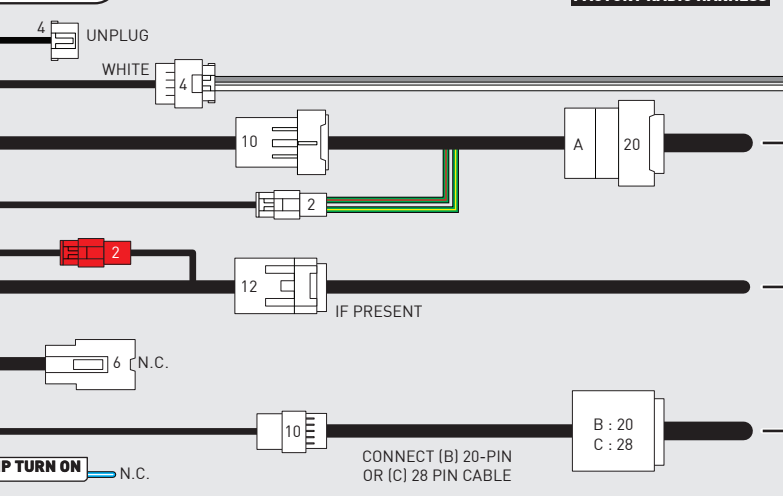

STEP 4

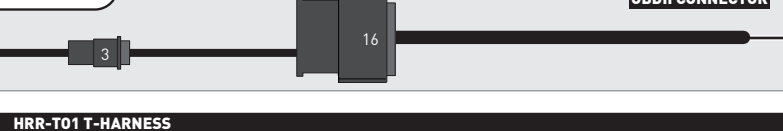

STEP 6

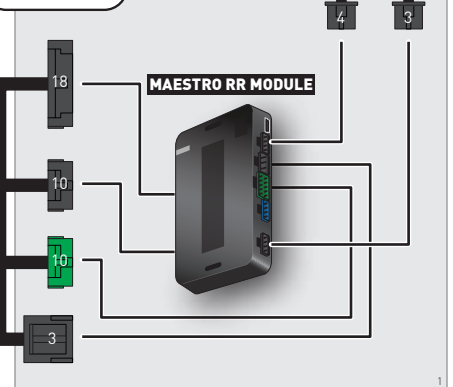

NOT REQUIRED

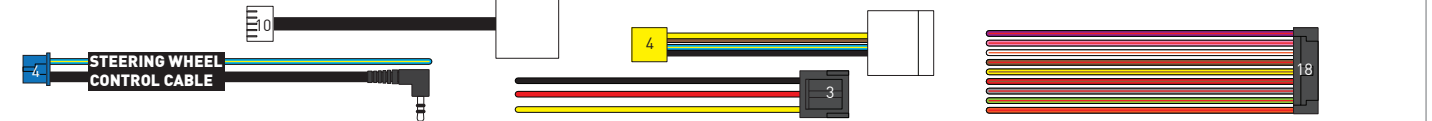

RADIO WIRE REFERENCE CHART

T01 T-harness Wire Description	Polarity	Wire Color on Maestro T-Harness	Wire Color on Alpine cable	Wire Color on Kenwood/ JVC cable	Wire Color on Pioneer cable	Wire Color on Sony cable
Illumination	(+)	Orange	N/A	Orange/White	Orange/White	Orange
Reverse Light*	(+)	Purple/White	Orange/White	Purple/White	Purple/White	Purple/White
E-Brake	(-)	Lt Green	Yellow/Blue	Lt Green	Lt Green	Lt Green
VSS (vehicle speed sensor)	(DATA)	Pink	Green/White	Pink	Pink	N/A

Head unit adapter wiring (optional accessory, sold separately)

ACC-HU-ALP1 Wire Description	Polarity	Wire Color on Adapter	Alpine Radio
VSS (vehicle speed sensor)	(DATA)	Green/White	Green/White

ACC-HU-KEN1 Wire Description	Polarity	Wire Color on Adapter	Kenwood Radio
CAM	(+)	Green/Red	Refer to camera/radio manual
CAM	(-)	Green/White	Refer to camera/radio manual
Steering Wheel Controls	(DATA)	Blue/Yellow	n/a

ACC-HU-KEN2 Wire Description	Polarity	Wire Color on Adapter	Kenwood Radio
E-Brake	(-)	LtGreen	LtGreen
Reverse Light*	(+)	Purple/White	Purple/White
Steering Wheel Controls	(DATA)	Blue/Yellow	n/a

* Reverse light wire: Only connect to radio or module damage will occur.

MODULE DIAGNOSTICS



LED 1 Module/Firmware status	LED 2 (RR2) Bluetooth activity	LED STATUS	DIAGNOSTIC
or		RED or GREEN flashing	LED flashes 1 or more times, either red or green, when a steering wheel button is pressed : normal operation.
		1 RED flash	Module has no firmware. Flash module using Weblink Desktop and log in. Do <u>NOT</u> use DEMO MODE.
		2 RED flashes	Problem detected. Consult troubleshooting table.
		1 GREEN flash	After radio boots up : Normal operation.
		3 GREEN flashes	Bluetooth is activated. Turns off after one minute: Normal operation.
		OFF	Normal operation (inactive).

VIDEO HELP		Installation, product information, vehicle specific videos.
VERIFY FLASH		Last flash information, steering control configuration, vehicle information.
WEBLINK		Software to program module.

TROUBLESHOOTING TABLE

PROBLEM	SOLUTION
Gauges do not work, radio shows OBD2 Error 1 or Error 2.	<p>Ensure OBDII connector is securely attached to the OBDII connector of the vehicle.</p> <p>If you hardwired connections at the OBDII, check connections at the OBDII connector. Make sure the RED/BROWN wire is on PIN 6 and the YELLOW/BROWN wire is connected to PIN 14 of the OBDII connector. Do not use T-Taps. Soldering or military splicing methods are recommended.</p> <p>If anything else is connected to the OBD2 or CAN wires of vehicle (programmer, throttle controller, insurance tracker, etc.) try unplugging it to see if gauges work. If gauges work without it installed, call tech support for options.</p> <p>Reset the RR.</p>
The light on the Maestro is blinking RED TWICE and the radio IS turning on.	<p>Ensure the 4-pin data cable is connected between the radio and the RR, and that it is plugged into the black port on the Maestro RR. The red and blue ports on the RR should be empty.</p> <p>Make sure the correct radio model and serial number were entered during the flash. Verify the radio's serial number entered during the flash matches what is listed on the radio screen. This can be found in the settings of the radio, listed as Device Id, Device Number, or Serial Number.</p>
The light on the Maestro is blinking RED TWICE but the radio is NOT turning on.	<p>If installing a modular radio and it is not turning on, ensure the screen is secured and any trim pieces on the radio have been installed fully. Not installing these fully will prevent radio from powering up and show a 2x red error as well.</p> <p>Test red and yellow wires for DC voltage at radio using a multimeter. Contact support if no voltage on red or yellow.</p>
The steering wheel controls are not working, the Maestro RR does not blink when they are pressed.	<p>Ensure the 20 or 28-pin connector is plugged to the vehicle and to the T01 T-harness, as shown in step 3 (this is where the RR gets the steering wheel signal from the vehicle).</p>
(Prius only) After the car is turned off, the radio stays on. The car stays in accessory mode and will not turn off.	<p>Locate the white 12-pin connector of the T01 harness, it is connected to the vehicle harness.</p> <p>Then, cut and isolate the red wire located at pin 11. The radio will shut off when the vehicle is turned off.</p>

MAESTRO RR RESET PROCEDURE:

Turn the key to the OFF position, then disconnect all connectors from the module.

Press and hold the module's programming button and connect all the connectors back to the module. Wait, the module's LED will flash RED rapidly (this may take up to 10 seconds).

Release the programming button. Wait, the LED will turn solid GREEN for 2 seconds to show the reset was successful.

TECHNICAL ASSISTANCE

Phone: 1-866-427-2999

Email: maestro.support@idatalink.com

IMPORTANT: To ensure proper operation, the aftermarket radio needs to have the latest firmware from the manufacturer. Please visit the radio manufacturer's website and look for any updates pertaining to your radio.

RETAINS STEERING WHEEL CONTROLS, FACTORY AMPLIFIER, AND MORE!



PRODUCTS REQUIRED

iDataLink Maestro RR or RR2 Radio Replacement Interface
iDataLink Maestro HRR-T01 Installation Harness

PROGRAMMED FIRMWARE

ADS-RR(SR)-TOY01-DS

ADDITIONAL RESOURCES

[Maestro RR2 Programmable Outputs Guide](#)

OPTIONAL ACCESSORIES

K40[™]
ELECTRONICS
ESCORT

Click here for:
[Radar Installation Guides](#)

HEAD UNIT ADAPTER:
ACC-HU-PI01, SON1, KEN1, KEN2, ALP1

WELCOME

Congratulations on the purchase of your iDatalink Maestro RR Radio replacement solution. You are now a few simple steps away from enjoying your new car radio with enhanced features.

Before starting your installation, please ensure that your iDatalink Maestro module is programmed with the correct firmware for your vehicle and that you carefully review the install guide.

Please note that Maestro RR will only retain functionalities that were originally available in the vehicle.

TABLE OF CONTENTS

Installation Instructions	3
Wiring Diagram	4
Radio Wire Reference Chart	5
Module Diagnostics	6
Troubleshooting Table	7

NEED HELP?

 1 866 427-2999

 maestro.support@idatalink.com

INSTALLATION INSTRUCTIONS P1/1

STEP 1

Remove the factory radio

If using head unit adapter (sold separately), connect HRR-T01 harness to adapter and skip to step 2.

- Unbox the aftermarket radio and locate its main harness.
- Cut and remove the black 20 pin connector from the HRR-T01 T-harness and connect the wires, shown in the wiring diagram, from aftermarket radio main harness to the HRR-T01 T-harness and match the wire functions.

Note: only connect purple/white wire to radio reverse input or module damage will occur.

STEP 2

- If the vehicle is equipped with an OEM backup camera, connect the HRR-T01 harness to any HRR adapter cable (D, E or F) then cut off the 16 or 24-pin connector. Connect the adapter's wires to parking assist ECU harness, as shown in wiring diagram.

STEP 3

- Identify if your vehicle has a 20 or 28 pin secondary connector.
- Assemble T01 T-harness as shown on wiring diagram.
- Connect the factory harness to the HRR-T01 harness.

STEP 4

- Connect HRR-T01 3-pin black connector to black connector of OBDII extension harness.
- Plug the OBDII connector into the OBDII of the vehicle.

STEP 5

- Plug the harnesses into the aftermarket radio.
- Connect the backup camera RCA cable into the aftermarket radio (if equipped).
- Connect the left front and right front low level outputs RCA cables into the aftermarket radio.
- Plug the Data cable to the data port of the aftermarket radio.
- Insert the Audio cable into the iDatalink 3.5 mm audio jack of the aftermarket radio (if there is no iDatalink audio input,

connect to AUX).

Note: On Pioneer radio, ensure that there is nothing plugged into the W/R port.

STEP 6

- Connect all the harnesses to the Maestro RR module then test your installation.

WIRING DIAGRAM *with an Amplifier*

STEP 1

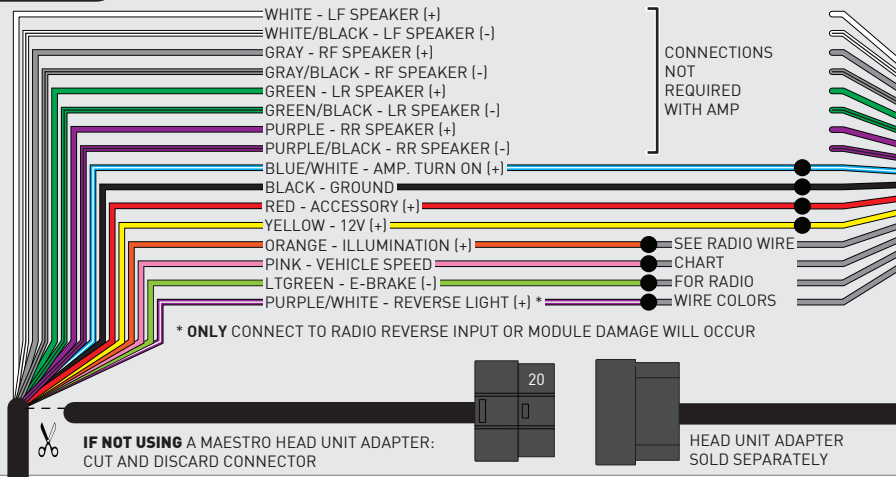

STEP 5

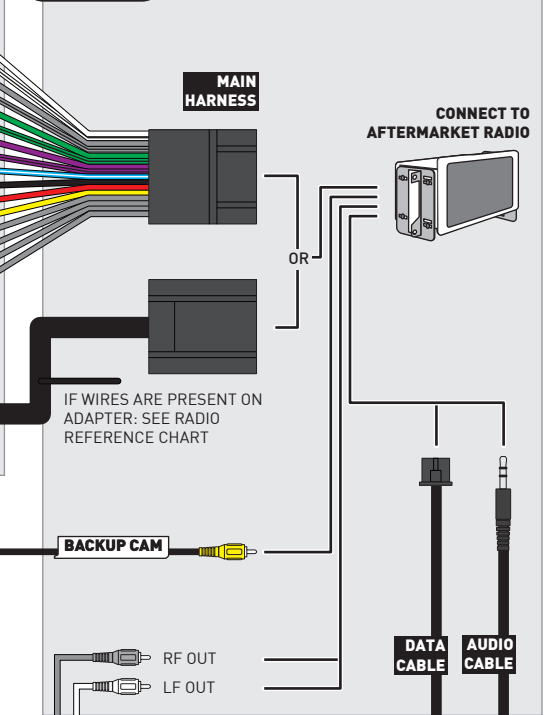

STEP 2

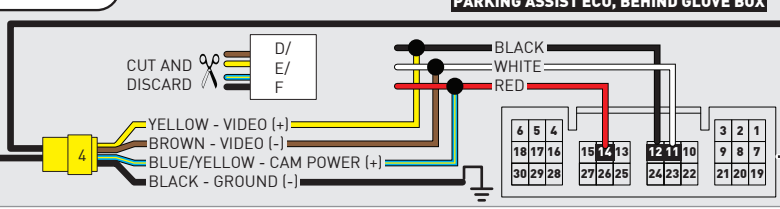

STEP 3

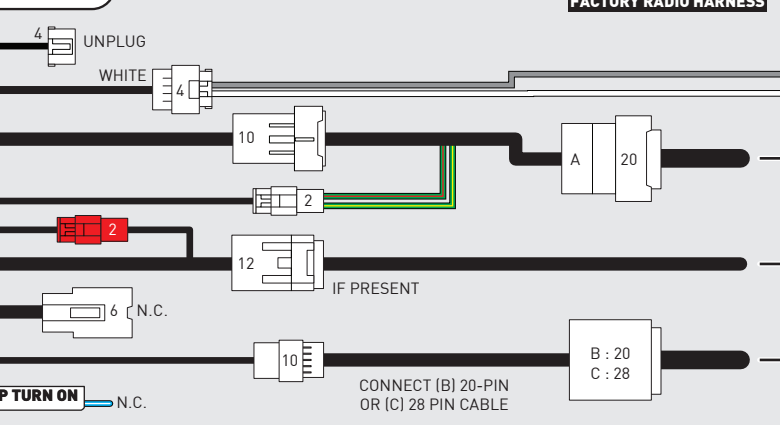

STEP 4



STEP 6

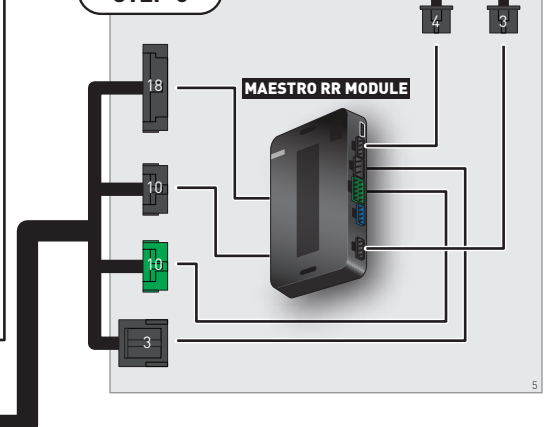

NOT REQUIRED

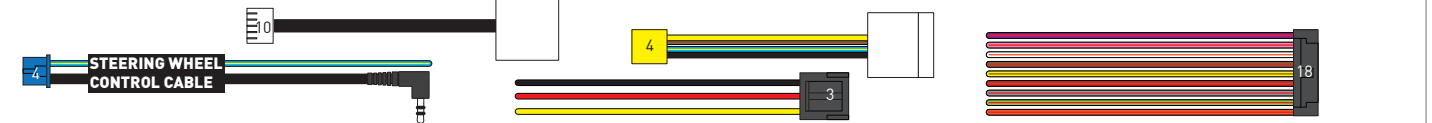

RADIO WIRE REFERENCE CHART

T01 T-harness Wire Description	Polarity	Wire Color on Maestro T-Harness	Wire Color on Alpine cable	Wire Color on Kenwood/JVC cable	Wire Color on Pioneer cable	Wire Color on Sony cable
Illumination	(+)	Orange	N/A	Orange/White	Orange/White	Orange
Reverse Light*	(+)	Purple/White	Orange/White	Purple/White	Purple/White	Purple/White
E-Brake	(-)	Lt Green	Yellow/Blue	Lt Green	Lt Green	Lt Green
VSS (vehicle speed sensor)	(DATA)	Pink	Green/White	Pink	Pink	N/A

Head unit adapter wiring (optional accessory, sold separately)

ACC-HU-ALP1 Wire Description	Polarity	Wire Color on Adapter	Alpine Radio
VSS (vehicle speed sensor)	(DATA)	Green/White	Green/White









ACC-HU-KEN1 Wire Description	Polarity	Wire Color on Adapter	Kenwood Radio
CAM	(+)	Green/Red	Refer to camera/radio manual
CAM	(-)	Green/White	Refer to camera/radio manual
Steering Wheel Controls	(DATA)	Blue/Yellow	n/a

ACC-HU-KEN2 Wire Description	Polarity	Wire Color on Adapter	Kenwood Radio
E-Brake	(-)	LtGreen	LtGreen
Reverse Light*	(+)	Purple/White	Purple/White
Steering Wheel Controls	(DATA)	Blue/Yellow	n/a

* Reverse light wire: Only connect to radio or module damage will occur.

MODULE DIAGNOSTICS



LED 1 Module/Firmware status	LED 2 (RR2) Bluetooth activity	LED STATUS	DIAGNOSTIC
 or 		RED or GREEN flashing	LED flashes 1 or more times, either red or green, when a steering wheel button is pressed : normal operation.
		1 RED flash	Module has no firmware. Flash module using Weblink Desktop and log in. Do <u>NOT</u> use DEMO MODE.
		2 RED flashes	Problem detected. Consult troubleshooting table.
		1 GREEN flash	After radio boots up : Normal operation.
		3 GREEN flashes	Bluetooth is activated. Turns off after one minute: Normal operation.
		OFF	Normal operation (inactive).

VIDEO HELP		Installation, product information, vehicle specific videos.
VERIFY FLASH		Last flash information, steering control configuration, vehicle information.
WEBLINK		Software to program module.

TROUBLESHOOTING TABLE

PROBLEM	SOLUTION
Gauges do not work, radio shows OBD2 Error 1 or Error 2.	<p>Ensure OBDII connector is securely attached to the OBDII connector of the vehicle.</p> <p>If you hardwired connections at the OBDII, check connections at the OBDII connector. Make sure the RED/BROWN wire is on PIN 6 and the YELLOW/BROWN wire is connected to PIN 14 of the OBDII connector. Do not use T-Taps. Soldering or military splicing methods are recommended.</p> <p>If anything else is connected to the OBD2 or CAN wires of vehicle (programmer, throttle controller, insurance tracker, etc.) try unplugging it to see if gauges work. If gauges work without it installed, call tech support for options.</p> <p>Reset the RR.</p>
The light on the Maestro is blinking RED TWICE and the radio IS turning on.	<p>Ensure the 4-pin data cable is connected between the radio and the RR, and that it is plugged into the black port on the Maestro RR. The red and blue ports on the RR should be empty.</p> <p>Make sure the correct radio model and serial number were entered during the flash. Verify the radio's serial number entered during the flash matches what is listed on the radio screen. This can be found in the settings of the radio, listed as Device Id, Device Number, or Serial Number.</p>
The light on the Maestro is blinking RED TWICE but the radio is NOT turning on.	<p>If installing a modular radio and it is not turning on, ensure the screen is secured and any trim pieces on the radio have been installed fully. Not installing these fully will prevent radio from powering up and show a 2x red error as well.</p> <p>Test red and yellow wires for DC voltage at radio using a multimeter. Contact support if no voltage on red or yellow.</p>
The steering wheel controls are not working, the Maestro RR does not blink when they are pressed.	<p>Ensure the 20 or 28-pin connector is plugged to the vehicle and to the T01 T-harness, as shown in step 3 (this is where the RR gets the steering wheel signal from the vehicle).</p>
(Prius only) After the car is turned off, the radio stays on. The car stays in accessory mode and will not turn off.	<p>Locate the white 12-pin connector of the T01 harness, it is connected to the vehicle harness.</p> <p>Then, cut and isolate the red wire located at pin 11. The radio will shut off when the vehicle is turned off.</p>

MAESTRO RR RESET PROCEDURE:

Turn the key to the OFF position, then disconnect all connectors from the module.

Press and hold the module's programming button and connect all the connectors back to the module. Wait, the module's LED will flash RED rapidly (this may take up to 10 seconds).

Release the programming button. Wait, the LED will turn solid GREEN for 2 seconds to show the reset was successful.

TECHNICAL ASSISTANCE

Phone: 1-866-427-2999

Email: maestro.support@idatalink.com

IMPORTANT: To ensure proper operation, the aftermarket radio needs to have the latest firmware from the manufacturer. Please visit the radio manufacturer's website and look for any updates pertaining to your radio.

RETAINS STEERING WHEEL CONTROLS, FACTORY AMPLIFIER, AND MORE!



PRODUCTS REQUIRED

iDatalink Maestro RR or RR2 Radio Replacement Interface
iDatalink Maestro HRR-T01 Installation Harness

PROGRAMMED FIRMWARE

ADS-RR(SR)-TOY01-DS

ADDITIONAL RESOURCES

[Maestro RR2 Programmable Outputs Guide](#)

OPTIONAL ACCESSORIES

K40[™]
ELECTRONICS
ESCORT

Click here for:
[Radar Installation Guides](#)

HEAD UNIT ADAPTER:
ACC-HU-PI01, SON1, KEN1, KEN2, ALP1

WELCOME

Congratulations on the purchase of your iDatalink Maestro RR Radio replacement solution. You are now a few simple steps away from enjoying your new car radio with enhanced features.

Before starting your installation, please ensure that your iDatalink Maestro module is programmed with the correct firmware for your vehicle and that you carefully review the install guide.

Please note that Maestro RR will only retain functionalities that were originally available in the vehicle.

TABLE OF CONTENTS

Installation Instructions	3
Wiring Diagram	4
Radio Wire Reference Chart	5
Module Diagnostics	6
Troubleshooting Table	7

NEED HELP?

 1 866 427-2999

 maestro.support@idatalink.com

INSTALLATION INSTRUCTIONS P1/1

STEP 1

Remove the factory radio

If using head unit adapter (sold separately), connect HRR-T01 harness to adapter and skip to step 2.

- Unbox the aftermarket radio and locate its main harness.
- Cut and remove the black 20 pin connector from the HRR-T01 T-harness and connect the wires, shown in the wiring diagram, from aftermarket radio main harness to the HRR-T01 T-harness and match the wire functions.

Note: only connect purple/white wire to radio reverse input or module damage will occur.

STEP 2

- Identify if your vehicle has a 20 or 28 pin secondary connector.
- Assemble T01 T-harness as shown on wiring diagram.
- Connect the factory harness to the HRR-T01 harness.

STEP 3

- Connect HRR-T01 3-pin black connector to black connector of OBDII extension harness.
- Plug the OBDII connector into the OBDII of the vehicle.

STEP 4

- Plug the harnesses into the aftermarket radio.
- Plug the Data cable to the data port of the aftermarket radio.
- Insert the Audio cable into the iDatalink 3.5 mm audio jack of the aftermarket radio (if there is no iDatalink audio input, connect to AUX).

Note: On Pioneer radio, ensure that there is nothing plugged into the W/R port.

STEP 5

- Connect all the harnesses to the Maestro RR module then test your installation.

WIRING DIAGRAM *without an Amplifier*

STEP 1

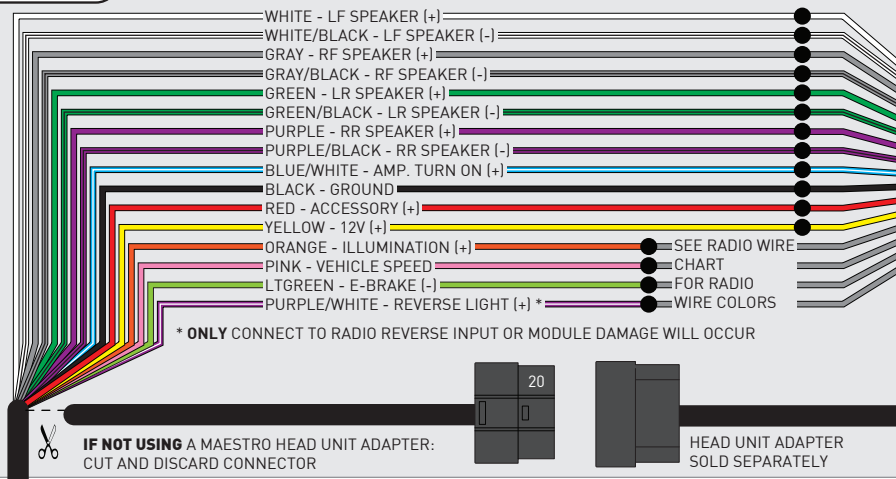

STEP 4

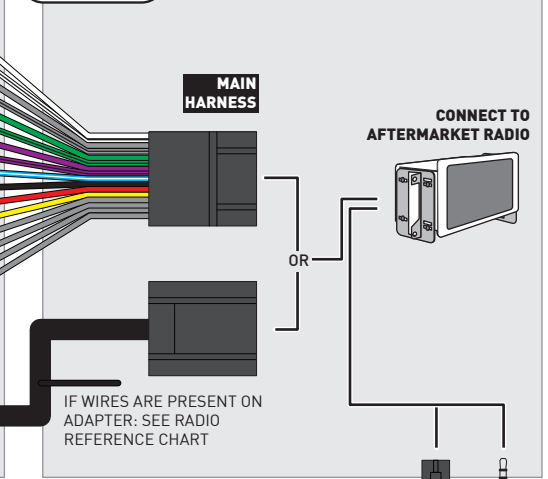

STEP 2

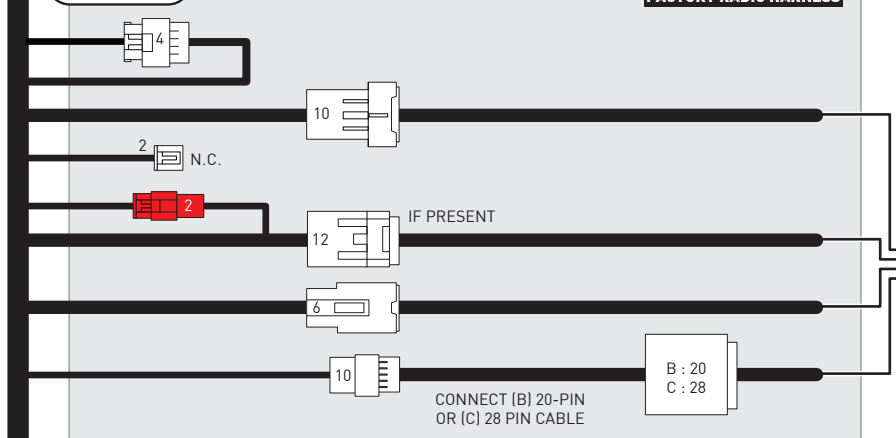

STEP 3

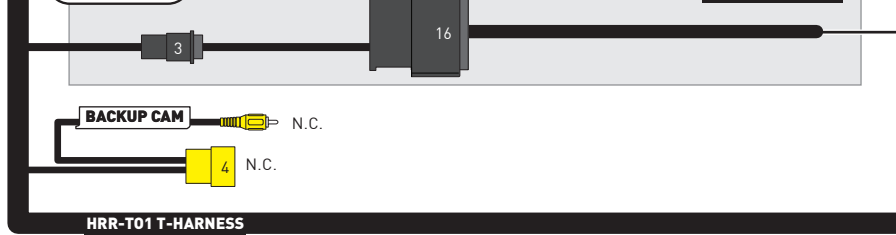

STEP 5

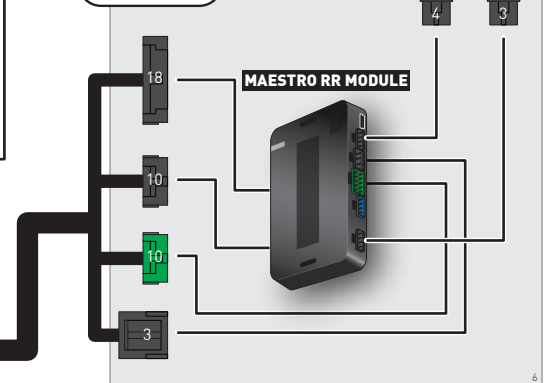

NOT REQUIRED

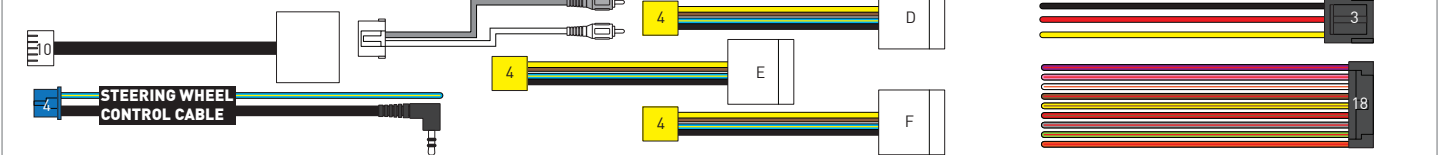

RADIO WIRE REFERENCE CHART

T01 T-harness Wire Description	Polarity	Wire Color on Maestro T-Harness	Wire Color on Alpine cable	Wire Color on Kenwood/JVC cable	Wire Color on Pioneer cable	Wire Color on Sony cable
Illumination	(+)	Orange	N/A	Orange/White	Orange/White	Orange
Reverse Light*	(+)	Purple/White	Orange/White	Purple/White	Purple/White	Purple/White
E-Brake	(-)	Lt Green	Yellow/Blue	Lt Green	Lt Green	Lt Green
VSS (vehicle speed sensor)	(DATA)	Pink	Green/White	Pink	Pink	N/A

Head unit adapter wiring (optional accessory, sold separately)

ACC-HU-ALP1 Wire Description	Polarity	Wire Color on Adapter	Alpine Radio
VSS (vehicle speed sensor)	(DATA)	Green/White	Green/White

ACC-HU-KEN1 Wire Description	Polarity	Wire Color on Adapter	Kenwood Radio
CAM	(+)	Green/Red	Refer to camera/radio manual
CAM	(-)	Green/White	Refer to camera/radio manual
Steering Wheel Controls	(DATA)	Blue/Yellow	n/a

ACC-HU-KEN2 Wire Description	Polarity	Wire Color on Adapter	Kenwood Radio
E-Brake	(-)	LtGreen	LtGreen
Reverse Light*	(+)	Purple/White	Purple/White
Steering Wheel Controls	(DATA)	Blue/Yellow	n/a

* Reverse light wire: Only connect to radio or module damage will occur.

MODULE DIAGNOSTICS



LED 1 Module/Firmware status	LED 2 (RR2) Bluetooth activity	LED STATUS	DIAGNOSTIC
or		RED or GREEN flashing	LED flashes 1 or more times, either red or green, when a steering wheel button is pressed : normal operation.
		1 RED flash	Module has no firmware. Flash module using Weblink Desktop and log in. Do <u>NOT</u> use DEMO MODE.
		2 RED flashes	Problem detected. Consult troubleshooting table.
		1 GREEN flash	After radio boots up : Normal operation.
		3 GREEN flashes	Bluetooth is activated. Turns off after one minute: Normal operation.
		OFF	Normal operation (inactive).

VIDEO HELP		Installation, product information, vehicle specific videos.
VERIFY FLASH		Last flash information, steering control configuration, vehicle information.
WEBLINK		Software to program module.

TROUBLESHOOTING TABLE

PROBLEM	SOLUTION
Gauges do not work, radio shows OBD2 Error 1 or Error 2.	<p>Ensure OBDII connector is securely attached to the OBDII connector of the vehicle.</p> <p>If you hardwired connections at the OBDII, check connections at the OBDII connector. Make sure the RED/BROWN wire is on PIN 6 and the YELLOW/BROWN wire is connected to PIN 14 of the OBDII connector. Do not use T-Taps. Soldering or military splicing methods are recommended.</p> <p>If anything else is connected to the OBD2 or CAN wires of vehicle (programmer, throttle controller, insurance tracker, etc.) try unplugging it to see if gauges work. If gauges work without it installed, call tech support for options.</p> <p>Reset the RR.</p>
The light on the Maestro is blinking RED TWICE and the radio IS turning on.	<p>Ensure the 4-pin data cable is connected between the radio and the RR, and that it is plugged into the black port on the Maestro RR. The red and blue ports on the RR should be empty.</p> <p>Make sure the correct radio model and serial number were entered during the flash. Verify the radio's serial number entered during the flash matches what is listed on the radio screen. This can be found in the settings of the radio, listed as Device Id, Device Number, or Serial Number.</p>
The light on the Maestro is blinking RED TWICE but the radio is NOT turning on.	<p>If installing a modular radio and it is not turning on, ensure the screen is secured and any trim pieces on the radio have been installed fully. Not installing these fully will prevent radio from powering up and show a 2x red error as well.</p> <p>Test red and yellow wires for DC voltage at radio using a multimeter. Contact support if no voltage on red or yellow.</p>
The steering wheel controls are not working, the Maestro RR does not blink when they are pressed.	<p>Ensure the 20 or 28-pin connector is plugged to the vehicle and to the T01 T-harness, as shown in step 3 (this is where the RR gets the steering wheel signal from the vehicle).</p>
(Prius only) After the car is turned off, the radio stays on. The car stays in accessory mode and will not turn off.	<p>Locate the white 12-pin connector of the T01 harness, it is connected to the vehicle harness.</p> <p>Then, cut and isolate the red wire located at pin 11. The radio will shut off when the vehicle is turned off.</p>

MAESTRO RR RESET PROCEDURE:

Turn the key to the OFF position, then disconnect all connectors from the module.

Press and hold the module's programming button and connect all the connectors back to the module. Wait, the module's LED will flash RED rapidly (this may take up to 10 seconds).

Release the programming button. Wait, the LED will turn solid GREEN for 2 seconds to show the reset was successful.

TECHNICAL ASSISTANCE

Phone: 1-866-427-2999

Email: maestro.support@idatalink.com

IMPORTANT: To ensure proper operation, the aftermarket radio needs to have the latest firmware from the manufacturer. Please visit the radio manufacturer's website and look for any updates pertaining to your radio.

RETAINS STEERING WHEEL CONTROLS, FACTORY AMPLIFIER, AND MORE!



PRODUCTS REQUIRED

iDataLink Maestro RR or RR2 Radio Replacement Interface
iDataLink Maestro HRR-T01 Installation Harness

PROGRAMMED FIRMWARE

ADS-RR(SR)-TOY01-DS

ADDITIONAL RESOURCES

[Maestro RR2 Programmable Outputs Guide](#)

OPTIONAL ACCESSORIES

K40[™]
ELECTRONICS
ESCORT

Click here for:
[Radar Installation Guides](#)

HEAD UNIT ADAPTER:
ACC-HU-PI01, SON1, KEN1, KEN2, ALP1

WELCOME

Congratulations on the purchase of your iDatalink Maestro RR Radio replacement solution. You are now a few simple steps away from enjoying your new car radio with enhanced features.

Before starting your installation, please ensure that your iDatalink Maestro module is programmed with the correct firmware for your vehicle and that you carefully review the install guide.

Please note that Maestro RR will only retain functionalities that were originally available in the vehicle.

NEED HELP?

 1 866 427-2999

 maestro.support@idatalink.com

TABLE OF CONTENTS

Installation Instructions	3
Wiring Diagram	4
Radio Wire Reference Chart	5
Module Diagnostics	6
Troubleshooting Table	7

INSTALLATION INSTRUCTIONS P1/1

STEP 1

Remove the factory radio

If using head unit adapter (sold separately), connect HRR-T01 harness to adapter and skip to step 2.

- Unbox the aftermarket radio and locate its main harness.
- Cut and remove the black 20 pin connector from the HRR-T01 T-harness and connect the wires, shown in the wiring diagram, from aftermarket radio main harness to the HRR-T01 T-harness and match the wire functions.

Note: only connect purple/white wire to radio reverse input or module damage will occur.

STEP 2

- If the vehicle is equipped with an OEM backup camera, connect the HRR-T01 harness to any HRR adapter cable (D, E or F) then cut off the 16 or 24-pin connector. Connect the adapter's wires to reverse camera harness, as shown in wiring diagram.
- Assemble T01 T-harness as shown on wiring diagram.
- Connect the factory harness to the HRR-T01 harness.

STEP 3

- Connect HRR-T01 3-pin black connector to black connector of OBDII extension harness.
- Plug the OBDII connector into the OBDII of the vehicle.

STEP 4

- Plug the harnesses into the aftermarket radio.
- Connect the backup camera RCA cable into the aftermarket radio (if equipped).
- Plug the Data cable to the data port of the aftermarket radio.
- Insert the Audio cable into the iDatalink 3.5 mm audio jack of the aftermarket radio (if there is no iDatalink audio input, connect to AUX).

Note: On Pioneer radio, ensure that there is nothing plugged into the W/R port.

STEP 5

- Connect all the harnesses to the Maestro RR module then test your installation.

WIRING DIAGRAM *without an Amplifier*

STEP 1

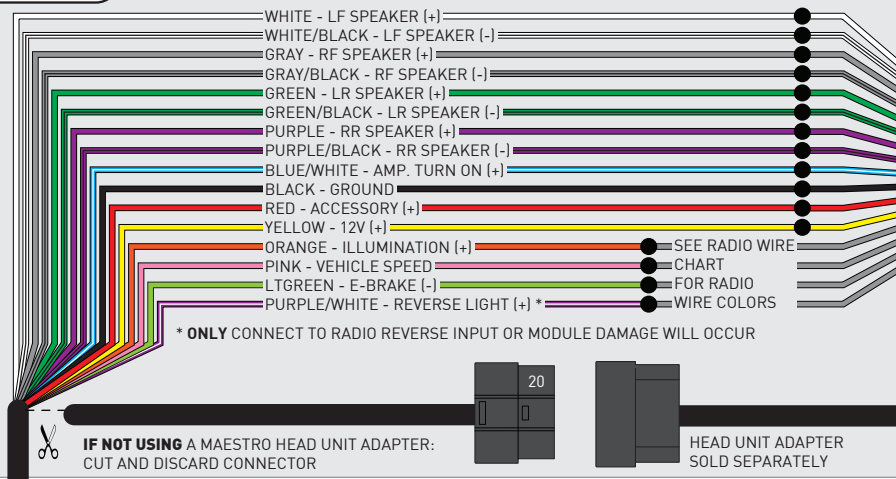

STEP 4

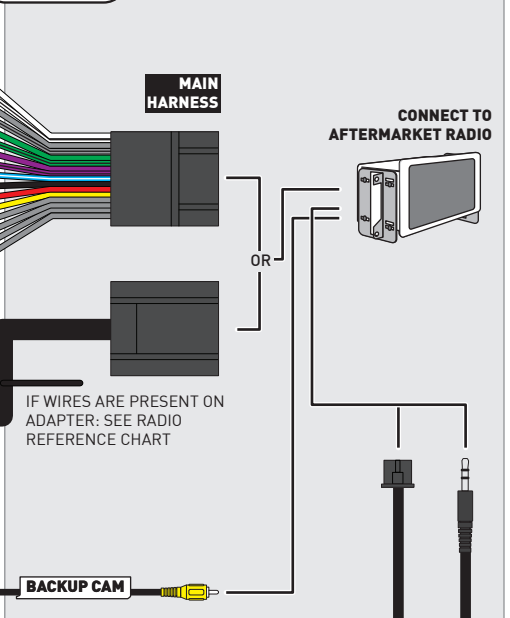

STEP 2

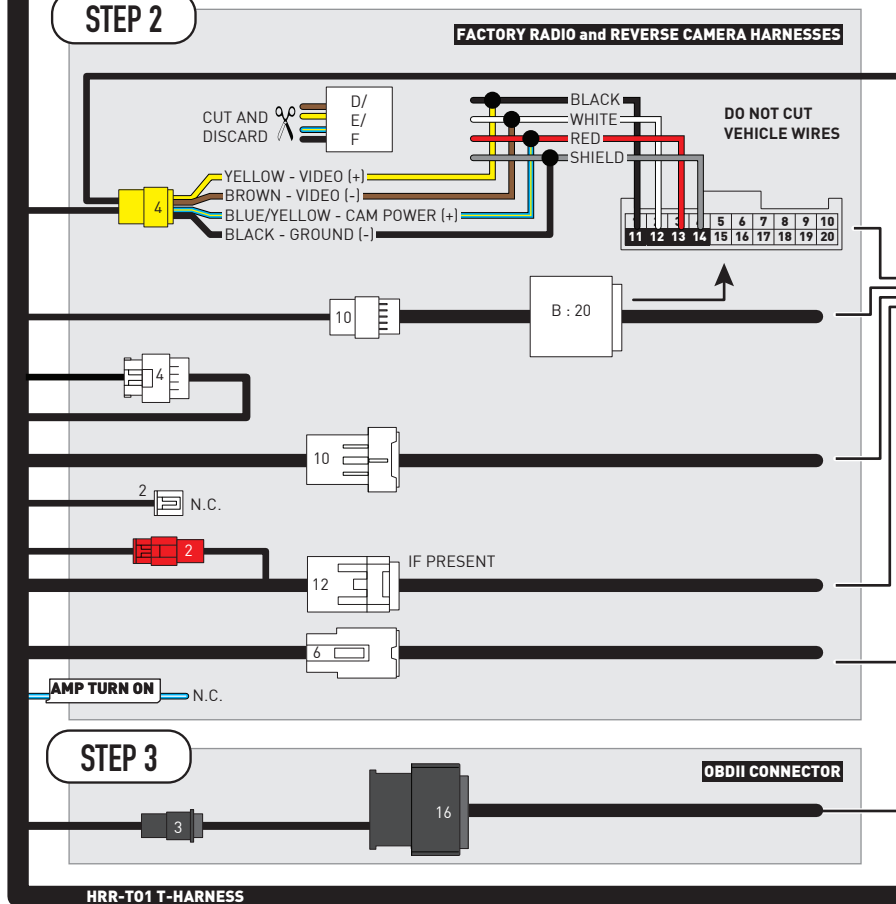

STEP 5

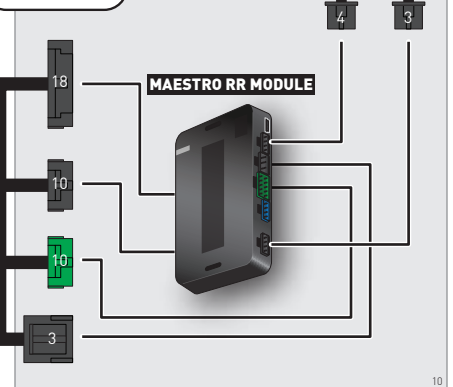

NOT REQUIRED

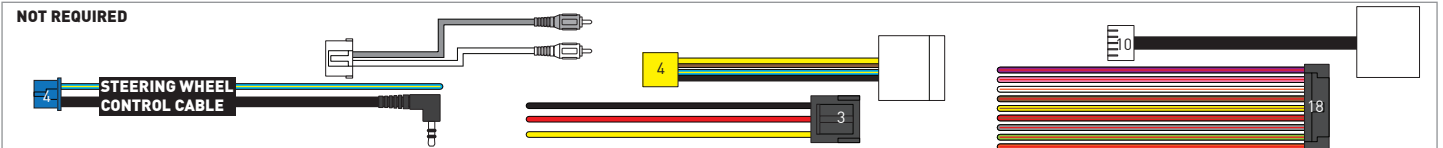

RADIO WIRE REFERENCE CHART

T01 T-harness Wire Description	Polarity	Wire Color on Maestro T-Harness	Wire Color on Alpine cable	Wire Color on Kenwood/ JVC cable	Wire Color on Pioneer cable	Wire Color on Sony cable
Illumination	(+)	Orange	N/A	Orange/White	Orange/White	Orange
Reverse Light*	(+)	Purple/White	Orange/White	Purple/White	Purple/White	Purple/White
E-Brake	(-)	Lt Green	Yellow/Blue	Lt Green	Lt Green	Lt Green
VSS (vehicle speed sensor)	(DATA)	Pink	Green/White	Pink	Pink	N/A

Head unit adapter wiring (optional accessory, sold separately)

ACC-HU-ALP1 Wire Description	Polarity	Wire Color on Adapter	Alpine Radio
VSS (vehicle speed sensor)	(DATA)	Green/White	Green/White

ACC-HU-KEN1 Wire Description	Polarity	Wire Color on Adapter	Kenwood Radio
CAM	(+)	Green/Red	Refer to camera/radio manual
CAM	(-)	Green/White	Refer to camera/radio manual
Steering Wheel Controls	(DATA)	Blue/Yellow	n/a

ACC-HU-KEN2 Wire Description	Polarity	Wire Color on Adapter	Kenwood Radio
E-Brake	(-)	LtGreen	LtGreen
Reverse Light*	(+)	Purple/White	Purple/White
Steering Wheel Controls	(DATA)	Blue/Yellow	n/a

* Reverse light wire: Only connect to radio or module damage will occur.

MODULE DIAGNOSTICS



LED 1 Module/Firmware status	LED 2 (RR2) Bluetooth activity	LED STATUS	DIAGNOSTIC
or		RED or GREEN flashing	LED flashes 1 or more times, either red or green, when a steering wheel button is pressed : normal operation.
		1 RED flash	Module has no firmware. Flash module using Weblink Desktop and log in. Do <u>NOT</u> use DEMO MODE.
		2 RED flashes	Problem detected. Consult troubleshooting table.
		1 GREEN flash	After radio boots up : Normal operation.
		3 GREEN flashes	Bluetooth is activated. Turns off after one minute: Normal operation.
		OFF	Normal operation (inactive).

VIDEO HELP		Installation, product information, vehicle specific videos.
VERIFY FLASH		Last flash information, steering control configuration, vehicle information.
WEBLINK		Software to program module.

TROUBLESHOOTING TABLE

PROBLEM	SOLUTION
Gauges do not work, radio shows OBD2 Error 1 or Error 2.	<p>Ensure OBDII connector is securely attached to the OBDII connector of the vehicle.</p> <p>If you hardwired connections at the OBDII, check connections at the OBDII connector. Make sure the RED/BROWN wire is on PIN 6 and the YELLOW/BROWN wire is connected to PIN 14 of the OBDII connector. Do not use T-Taps. Soldering or military splicing methods are recommended.</p> <p>If anything else is connected to the OBD2 or CAN wires of vehicle (programmer, throttle controller, insurance tracker, etc.) try unplugging it to see if gauges work. If gauges work without it installed, call tech support for options.</p> <p>Reset the RR.</p>
The light on the Maestro is blinking RED TWICE and the radio IS turning on.	<p>Ensure the 4-pin data cable is connected between the radio and the RR, and that it is plugged into the black port on the Maestro RR. The red and blue ports on the RR should be empty.</p> <p>Make sure the correct radio model and serial number were entered during the flash. Verify the radio's serial number entered during the flash matches what is listed on the radio screen. This can be found in the settings of the radio, listed as Device Id, Device Number, or Serial Number.</p>
The light on the Maestro is blinking RED TWICE but the radio is NOT turning on.	<p>If installing a modular radio and it is not turning on, ensure the screen is secured and any trim pieces on the radio have been installed fully. Not installing these fully will prevent radio from powering up and show a 2x red error as well.</p> <p>Test red and yellow wires for DC voltage at radio using a multimeter. Contact support if no voltage on red or yellow.</p>
The steering wheel controls are not working, the Maestro RR does not blink when they are pressed.	<p>Ensure the 20 or 28-pin connector is plugged to the vehicle and to the T01 T-harness, as shown in step 3 (this is where the RR gets the steering wheel signal from the vehicle).</p>
(Prius only) After the car is turned off, the radio stays on. The car stays in accessory mode and will not turn off.	<p>Locate the white 12-pin connector of the T01 harness, it is connected to the vehicle harness.</p> <p>Then, cut and isolate the red wire located at pin 11. The radio will shut off when the vehicle is turned off.</p>

MAESTRO RR RESET PROCEDURE:

Turn the key to the OFF position, then disconnect all connectors from the module.

Press and hold the module's programming button and connect all the connectors back to the module. Wait, the module's LED will flash RED rapidly (this may take up to 10 seconds).

Release the programming button. Wait, the LED will turn solid GREEN for 2 seconds to show the reset was successful.

TECHNICAL ASSISTANCE

Phone: 1-866-427-2999

Email: maestro.support@idatalink.com

IMPORTANT: To ensure proper operation, the aftermarket radio needs to have the latest firmware from the manufacturer. Please visit the radio manufacturer's website and look for any updates pertaining to your radio.

RETAINS STEERING WHEEL CONTROLS, FACTORY AMPLIFIER, AND MORE!



PRODUCTS REQUIRED

iDatalink Maestro RR or RR2 Radio Replacement Interface
iDatalink Maestro HRR-T01 Installation Harness

PROGRAMMED FIRMWARE

ADS-RR(SR)-TOY01-DS

ADDITIONAL RESOURCES

[Maestro RR2 Programmable Outputs Guide](#)

OPTIONAL ACCESSORIES

K40[™]
ELECTRONICS
ESCORT

Click here for:
[Radar Installation Guides](#)

HEAD UNIT ADAPTER:
ACC-HU-PI01, SON1, KEN1, KEN2, ALP1

WELCOME

Congratulations on the purchase of your iDatalink Maestro RR Radio replacement solution. You are now a few simple steps away from enjoying your new car radio with enhanced features.

Before starting your installation, please ensure that your iDatalink Maestro module is programmed with the correct firmware for your vehicle and that you carefully review the install guide.

Please note that Maestro RR will only retain functionalities that were originally available in the vehicle.

TABLE OF CONTENTS

Installation Instructions	3
Wiring Diagram	4
Radio Wire Reference Chart	5
Module Diagnostics	6
Troubleshooting Table	7

NEED HELP?

 1 866 427-2999

 maestro.support@idatalink.com

INSTALLATION INSTRUCTIONS P1/1

STEP 1

Remove the factory radio

If using head unit adapter (sold separately), connect HRR-T01 harness to adapter and skip to step 2.

- Unbox the aftermarket radio and locate its main harness.
- Cut and remove the black 20 pin connector from the HRR-T01 T-harness and connect the wires, shown in the wiring diagram, from aftermarket radio main harness to the HRR-T01 T-harness and match the wire functions.

Note: only connect purple/white wire to radio reverse input or module damage will occur.

STEP 2

- Identify if your vehicle has a 20 or 28 pin secondary connector.
- Assemble T01 T-harness as shown on wiring diagram.
- Connect the factory harness to the HRR-T01 harness.

STEP 3

- Connect HRR-T01 3-pin black connector to black connector of OBDII extension harness.
- Plug the OBDII connector into the OBDII of the vehicle.

STEP 4

- Plug the harnesses into the aftermarket radio.
- Connect the left front and right front low level outputs RCA cables into the aftermarket radio.
- Plug the Data cable to the data port of the aftermarket radio.
- Insert the Audio cable into the iDatalink 3.5 mm audio jack of the aftermarket radio (if there is no iDatalink audio input, connect to AUX).

Note: On Pioneer radio, ensure that there is nothing plugged into the W/R port.

STEP 5

- Connect all the harnesses to the Maestro RR module then test your installation.

WIRING DIAGRAM *with an Amplifier*

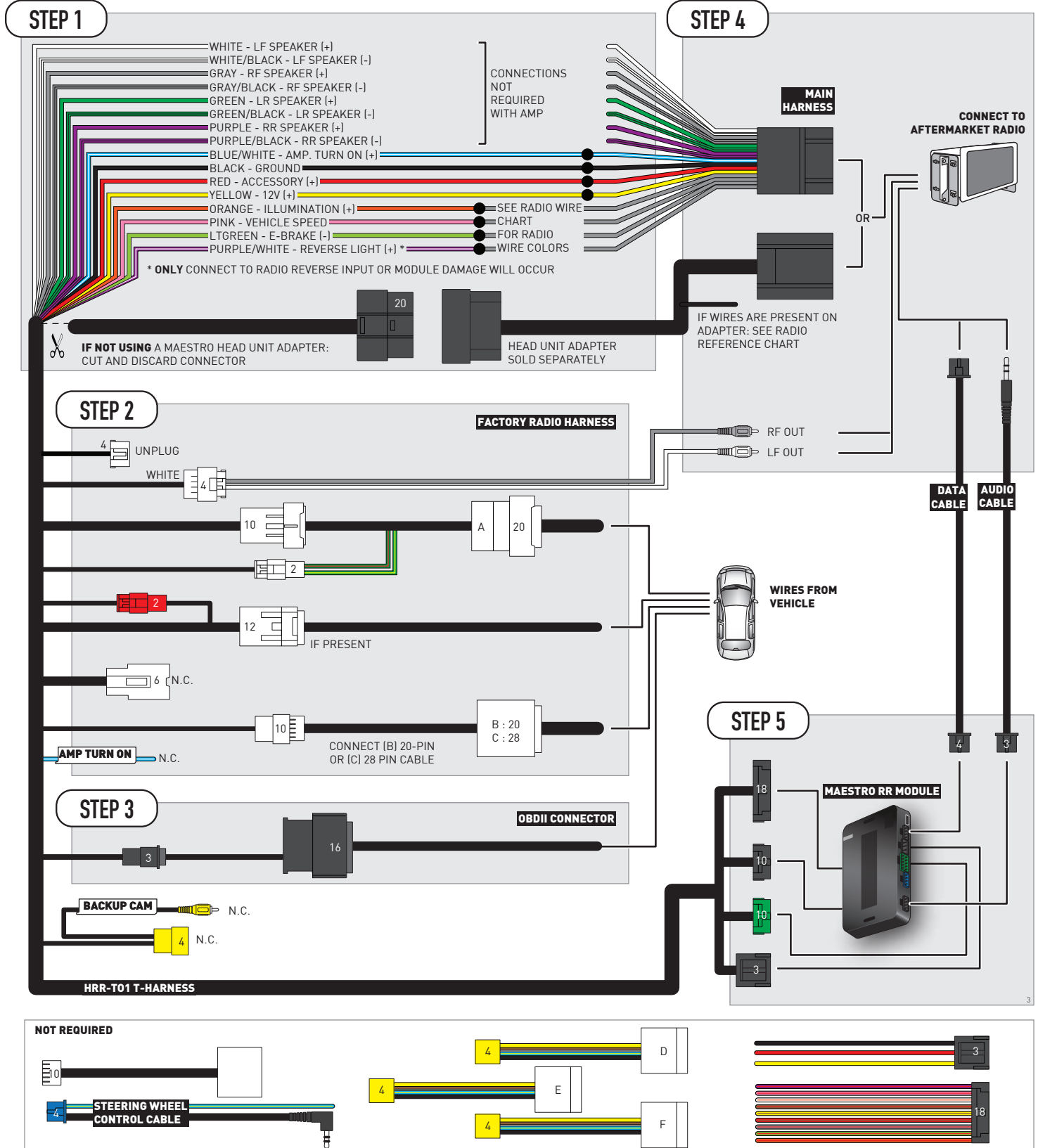

RADIO WIRE REFERENCE CHART

T01 T-harness Wire Description	Polarity	Wire Color on Maestro T-Harness	Wire Color on Alpine cable	Wire Color on Kenwood/JVC cable	Wire Color on Pioneer cable	Wire Color on Sony cable
Illumination	(+)	Orange	N/A	Orange/White	Orange/White	Orange
Reverse Light*	(+)	Purple/White	Orange/White	Purple/White	Purple/White	Purple/White
E-Brake	(-)	Lt Green	Yellow/Blue	Lt Green	Lt Green	Lt Green
VSS (vehicle speed sensor)	(DATA)	Pink	Green/White	Pink	Pink	N/A

Head unit adapter wiring (optional accessory, sold separately)

ACC-HU-ALP1 Wire Description	Polarity	Wire Color on Adapter	Alpine Radio
VSS (vehicle speed sensor)	(DATA)	Green/White	Green/White









ACC-HU-KEN1 Wire Description	Polarity	Wire Color on Adapter	Kenwood Radio
CAM	(+)	Green/Red	Refer to camera/radio manual
CAM	(-)	Green/White	Refer to camera/radio manual
Steering Wheel Controls	(DATA)	Blue/Yellow	n/a

ACC-HU-KEN2 Wire Description	Polarity	Wire Color on Adapter	Kenwood Radio
E-Brake	(-)	LtGreen	LtGreen
Reverse Light*	(+)	Purple/White	Purple/White
Steering Wheel Controls	(DATA)	Blue/Yellow	n/a

* Reverse light wire: Only connect to radio or module damage will occur.

MODULE DIAGNOSTICS



LED 1 Module/Firmware status	LED 2 (RR2) Bluetooth activity	LED STATUS	DIAGNOSTIC
 or 		RED or GREEN flashing	LED flashes 1 or more times, either red or green, when a steering wheel button is pressed : normal operation.
		1 RED flash	Module has no firmware. Flash module using Weblink Desktop and log in. Do <u>NOT</u> use DEMO MODE.
		2 RED flashes	Problem detected. Consult troubleshooting table.
		1 GREEN flash	After radio boots up : Normal operation.
		3 GREEN flashes	Bluetooth is activated. Turns off after one minute: Normal operation.
		OFF	Normal operation (inactive).

VIDEO HELP		Installation, product information, vehicle specific videos.
VERIFY FLASH		Last flash information, steering control configuration, vehicle information.
WEBLINK		Software to program module.

TROUBLESHOOTING TABLE

PROBLEM	SOLUTION
Gauges do not work, radio shows OBD2 Error 1 or Error 2.	<p>Ensure OBDII connector is securely attached to the OBDII connector of the vehicle.</p> <p>If you hardwired connections at the OBDII, check connections at the OBDII connector. Make sure the RED/BROWN wire is on PIN 6 and the YELLOW/BROWN wire is connected to PIN 14 of the OBDII connector. Do not use T-Taps. Soldering or military splicing methods are recommended.</p> <p>If anything else is connected to the OBD2 or CAN wires of vehicle (programmer, throttle controller, insurance tracker, etc.) try unplugging it to see if gauges work. If gauges work without it installed, call tech support for options.</p> <p>Reset the RR.</p>
The light on the Maestro is blinking RED TWICE and the radio IS turning on.	<p>Ensure the 4-pin data cable is connected between the radio and the RR, and that it is plugged into the black port on the Maestro RR. The red and blue ports on the RR should be empty.</p> <p>Make sure the correct radio model and serial number were entered during the flash. Verify the radio's serial number entered during the flash matches what is listed on the radio screen. This can be found in the settings of the radio, listed as Device Id, Device Number, or Serial Number.</p>
The light on the Maestro is blinking RED TWICE but the radio is NOT turning on.	<p>If installing a modular radio and it is not turning on, ensure the screen is secured and any trim pieces on the radio have been installed fully. Not installing these fully will prevent radio from powering up and show a 2x red error as well.</p> <p>Test red and yellow wires for DC voltage at radio using a multimeter. Contact support if no voltage on red or yellow.</p>
The steering wheel controls are not working, the Maestro RR does not blink when they are pressed.	<p>Ensure the 20 or 28-pin connector is plugged to the vehicle and to the T01 T-harness, as shown in step 3 (this is where the RR gets the steering wheel signal from the vehicle).</p>
(Prius only) After the car is turned off, the radio stays on. The car stays in accessory mode and will not turn off.	<p>Locate the white 12-pin connector of the T01 harness, it is connected to the vehicle harness.</p> <p>Then, cut and isolate the red wire located at pin 11. The radio will shut off when the vehicle is turned off.</p>

MAESTRO RR RESET PROCEDURE:

Turn the key to the OFF position, then disconnect all connectors from the module.

Press and hold the module's programming button and connect all the connectors back to the module. Wait, the module's LED will flash RED rapidly (this may take up to 10 seconds).

Release the programming button. Wait, the LED will turn solid GREEN for 2 seconds to show the reset was successful.

TECHNICAL ASSISTANCE

Phone: 1-866-427-2999

Email: maestro.support@idatalink.com

IMPORTANT: To ensure proper operation, the aftermarket radio needs to have the latest firmware from the manufacturer. Please visit the radio manufacturer's website and look for any updates pertaining to your radio.

RETAINS STEERING WHEEL CONTROLS, FACTORY AMPLIFIER, AND MORE!



PRODUCTS REQUIRED

iDatalink Maestro RR or RR2 Radio Replacement Interface
iDatalink Maestro HRR-T01 Installation Harness

PROGRAMMED FIRMWARE

ADS-RR(SR)-TOY01-DS

ADDITIONAL RESOURCES

[Maestro RR2 Programmable Outputs Guide](#)

OPTIONAL ACCESSORIES

K40[™]
ELECTRONICS
ESCORT

Click here for:
[Radar Installation Guides](#)

HEAD UNIT ADAPTER:
ACC-HU-PI01, SON1, KEN1, KEN2, ALP1

WELCOME

Congratulations on the purchase of your iDatalink Maestro RR Radio replacement solution. You are now a few simple steps away from enjoying your new car radio with enhanced features.

Before starting your installation, please ensure that your iDatalink Maestro module is programmed with the correct firmware for your vehicle and that you carefully review the install guide.

Please note that Maestro RR will only retain functionalities that were originally available in the vehicle.

TABLE OF CONTENTS

Installation Instructions	3
Wiring Diagram	4
Radio Wire Reference Chart	5
Module Diagnostics	6
Troubleshooting Table	7

NEED HELP?

 1 866 427-2999

 maestro.support@idatalink.com

INSTALLATION INSTRUCTIONS P1/1

STEP 1

Remove the factory radio

If using head unit adapter (sold separately), connect HRR-T01 harness to adapter and skip to step 2.

- Unbox the aftermarket radio and locate its main harness.
- Cut and remove the black 20 pin connector from the HRR-T01 T-harness and connect the wires, shown in the wiring diagram, from aftermarket radio main harness to the HRR-T01 T-harness and match the wire functions.

Note: only connect purple/white wire to radio reverse input or module damage will occur.

STEP 2

- If the vehicle is equipped with an OEM backup camera, connect the HRR-T01 harness to appropriate HRR adapter cable (D, E or F) then connect to the backup camera harness.

STEP 3

- Identify if your vehicle has a 20 or 28 pin secondary connector.
- Assemble T01 T-harness as shown on wiring diagram.
- Connect the factory harness to the HRR-T01 harness.

STEP 4

- Connect HRR-T01 3-pin black connector to black connector of OBDII extension harness.
- Plug the OBDII connector into the OBDII of the vehicle.

STEP 5

- Plug the harnesses into the aftermarket radio.
- Connect the backup camera RCA cable into the aftermarket radio (if equipped).
- Connect the left front and right front low level outputs RCA cables into the aftermarket radio.
- Plug the Data cable to the data port of the aftermarket radio.
- Insert the Audio cable into the iDatalink 3.5 mm audio jack of the aftermarket radio (if there is no iDatalink audio input, connect to AUX).

Note: On Pioneer radio, ensure that there is nothing plugged into the W/R port.

STEP 6

- Connect all the harnesses to the Maestro RR module then test your installation.

WIRING DIAGRAM *with an Amplifier*

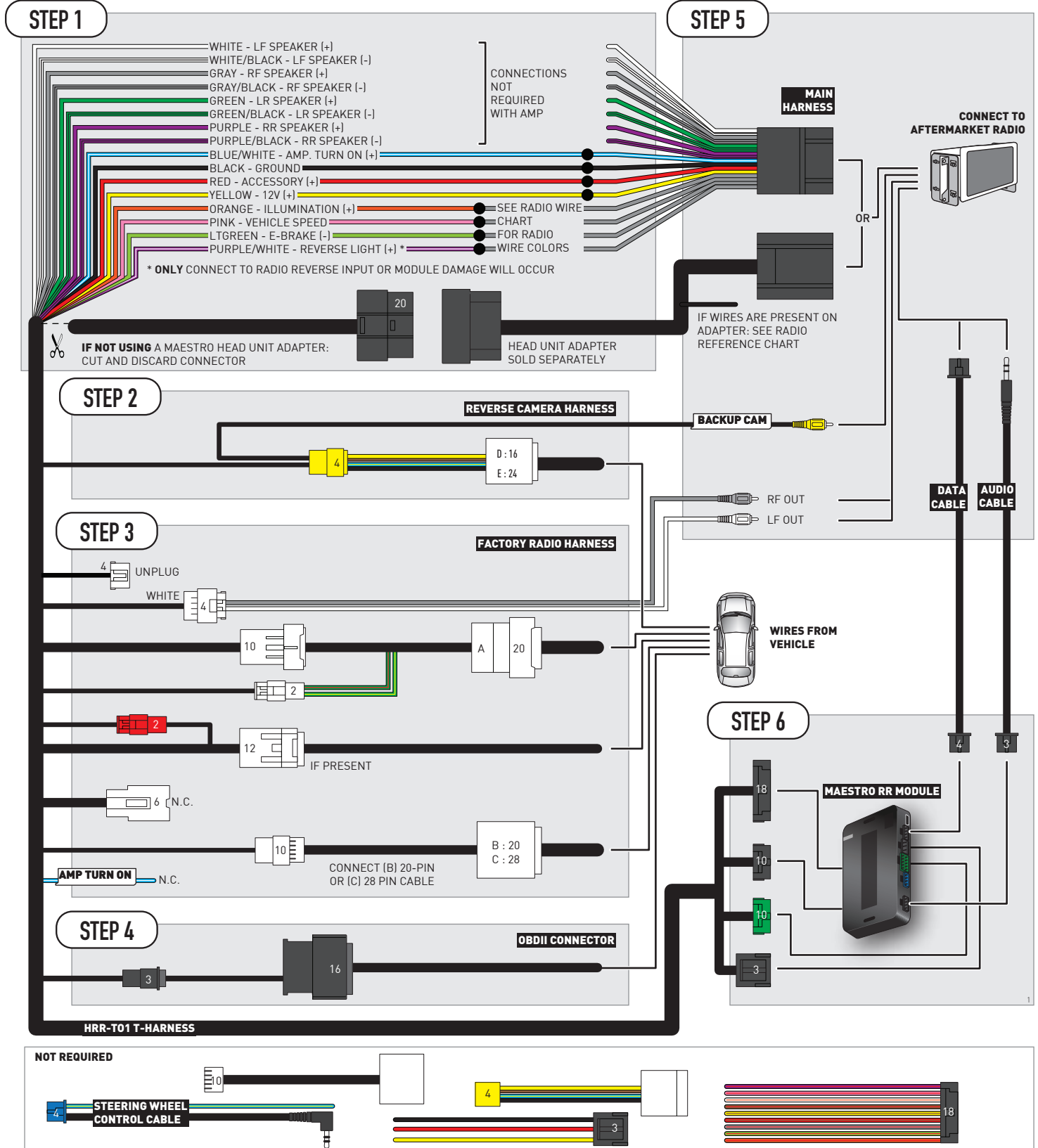

RADIO WIRE REFERENCE CHART

T01 T-harness Wire Description	Polarity	Wire Color on Maestro T-Harness	Wire Color on Alpine cable	Wire Color on Kenwood/JVC cable	Wire Color on Pioneer cable	Wire Color on Sony cable
Illumination	(+)	Orange	N/A	Orange/White	Orange/White	Orange
Reverse Light*	(+)	Purple/White	Orange/White	Purple/White	Purple/White	Purple/White
E-Brake	(-)	Lt Green	Yellow/Blue	Lt Green	Lt Green	Lt Green
VSS (vehicle speed sensor)	(DATA)	Pink	Green/White	Pink	Pink	N/A

Head unit adapter wiring (optional accessory, sold separately)

ACC-HU-ALP1 Wire Description	Polarity	Wire Color on Adapter	Alpine Radio
VSS (vehicle speed sensor)	(DATA)	Green/White	Green/White









ACC-HU-KEN1 Wire Description	Polarity	Wire Color on Adapter	Kenwood Radio
CAM	(+)	Green/Red	Refer to camera/radio manual
CAM	(-)	Green/White	Refer to camera/radio manual
Steering Wheel Controls	(DATA)	Blue/Yellow	n/a

ACC-HU-KEN2 Wire Description	Polarity	Wire Color on Adapter	Kenwood Radio
E-Brake	(-)	LtGreen	LtGreen
Reverse Light*	(+)	Purple/White	Purple/White
Steering Wheel Controls	(DATA)	Blue/Yellow	n/a

* Reverse light wire: Only connect to radio or module damage will occur.

MODULE DIAGNOSTICS



LED 1 Module/Firmware status	LED 2 (RR2) Bluetooth activity	LED STATUS	DIAGNOSTIC
 or 		RED or GREEN flashing	LED flashes 1 or more times, either red or green, when a steering wheel button is pressed : normal operation.
		1 RED flash	Module has no firmware. Flash module using Weblink Desktop and log in. Do <u>NOT</u> use DEMO MODE.
		2 RED flashes	Problem detected. Consult troubleshooting table.
		1 GREEN flash	After radio boots up : Normal operation.
		3 GREEN flashes	Bluetooth is activated. Turns off after one minute: Normal operation.
		OFF	Normal operation (inactive).

VIDEO HELP		Installation, product information, vehicle specific videos.
VERIFY FLASH		Last flash information, steering control configuration, vehicle information.
WEBLINK		Software to program module.

TROUBLESHOOTING TABLE

PROBLEM	SOLUTION
Gauges do not work, radio shows OBD2 Error 1 or Error 2.	<p>Ensure OBDII connector is securely attached to the OBDII connector of the vehicle.</p> <p>If you hardwired connections at the OBDII, check connections at the OBDII connector. Make sure the RED/BROWN wire is on PIN 6 and the YELLOW/BROWN wire is connected to PIN 14 of the OBDII connector. Do not use T-Taps. Soldering or military splicing methods are recommended.</p> <p>If anything else is connected to the OBD2 or CAN wires of vehicle (programmer, throttle controller, insurance tracker, etc.) try unplugging it to see if gauges work. If gauges work without it installed, call tech support for options.</p> <p>Reset the RR.</p>
The light on the Maestro is blinking RED TWICE and the radio IS turning on.	<p>Ensure the 4-pin data cable is connected between the radio and the RR, and that it is plugged into the black port on the Maestro RR. The red and blue ports on the RR should be empty.</p> <p>Make sure the correct radio model and serial number were entered during the flash. Verify the radio's serial number entered during the flash matches what is listed on the radio screen. This can be found in the settings of the radio, listed as Device Id, Device Number, or Serial Number.</p>
The light on the Maestro is blinking RED TWICE but the radio is NOT turning on.	<p>If installing a modular radio and it is not turning on, ensure the screen is secured and any trim pieces on the radio have been installed fully. Not installing these fully will prevent radio from powering up and show a 2x red error as well.</p> <p>Test red and yellow wires for DC voltage at radio using a multimeter. Contact support if no voltage on red or yellow.</p>
The steering wheel controls are not working, the Maestro RR does not blink when they are pressed.	<p>Ensure the 20 or 28-pin connector is plugged to the vehicle and to the T01 T-harness, as shown in step 3 (this is where the RR gets the steering wheel signal from the vehicle).</p>
(Prius only) After the car is turned off, the radio stays on. The car stays in accessory mode and will not turn off.	<p>Locate the white 12-pin connector of the T01 harness, it is connected to the vehicle harness.</p> <p>Then, cut and isolate the red wire located at pin 11. The radio will shut off when the vehicle is turned off.</p>

MAESTRO RR RESET PROCEDURE:

Turn the key to the OFF position, then disconnect all connectors from the module.

Press and hold the module's programming button and connect all the connectors back to the module. Wait, the module's LED will flash RED rapidly (this may take up to 10 seconds).

Release the programming button. Wait, the LED will turn solid GREEN for 2 seconds to show the reset was successful.

TECHNICAL ASSISTANCE

Phone: 1-866-427-2999

Email: maestro.support@idatalink.com

IMPORTANT: To ensure proper operation, the aftermarket radio needs to have the latest firmware from the manufacturer. Please visit the radio manufacturer's website and look for any updates pertaining to your radio.

RETAINS STEERING WHEEL CONTROLS, FACTORY AMPLIFIER, AND MORE!



PRODUCTS REQUIRED

iDatalink Maestro RR or RR2 Radio Replacement Interface
iDatalink Maestro HRR-T01 Installation Harness

PROGRAMMED FIRMWARE

ADS-RR(SR)-TOY01-DS

ADDITIONAL RESOURCES

[Maestro RR2 Programmable Outputs Guide](#)

OPTIONAL ACCESSORIES

K40[™]
ELECTRONICS
ESCORT

Click here for:
[Radar Installation Guides](#)

HEAD UNIT ADAPTER:
ACC-HU-PI01, SON1, KEN1, KEN2, ALP1

WELCOME

Congratulations on the purchase of your iDatalink Maestro RR Radio replacement solution. You are now a few simple steps away from enjoying your new car radio with enhanced features.

Before starting your installation, please ensure that your iDatalink Maestro module is programmed with the correct firmware for your vehicle and that you carefully review the install guide.

Please note that Maestro RR will only retain functionalities that were originally available in the vehicle.

TABLE OF CONTENTS

Installation Instructions	3
Wiring Diagram	4
Radio Wire Reference Chart	5
Module Diagnostics	6
Troubleshooting Table	7

NEED HELP?

 1 866 427-2999

 maestro.support@idatalink.com

INSTALLATION INSTRUCTIONS P1/1

STEP 1

Remove the factory radio

If using head unit adapter (sold separately), connect HRR-T01 harness to adapter and skip to step 2.

- Unbox the aftermarket radio and locate its main harness.
- Cut and remove the black 20 pin connector from the HRR-T01 T-harness and connect the wires, shown in the wiring diagram, from aftermarket radio main harness to the HRR-T01 T-harness and match the wire functions.

Note: only connect purple/white wire to radio reverse input or module damage will occur.

STEP 2

- Identify if your vehicle has a 20 or 28 pin secondary connector.
- Assemble T01 T-harness as shown on wiring diagram.
- Connect the factory harness to the HRR-T01 harness.

STEP 3

- Connect HRR-T01 3-pin black connector to black connector of OBDII extension harness.
- Plug the OBDII connector into the OBDII of the vehicle.

STEP 4

- Plug the harnesses into the aftermarket radio.
- Plug the Data cable to the data port of the aftermarket radio.
- Insert the Audio cable into the iDatalink 3.5 mm audio jack of the aftermarket radio (if there is no iDatalink audio input, connect to AUX).

Note: On Pioneer radio, ensure that there is nothing plugged into the W/R port.

STEP 5

- Connect all the harnesses to the Maestro RR module then test your installation.

WIRING DIAGRAM *without an Amplifier*

STEP 1

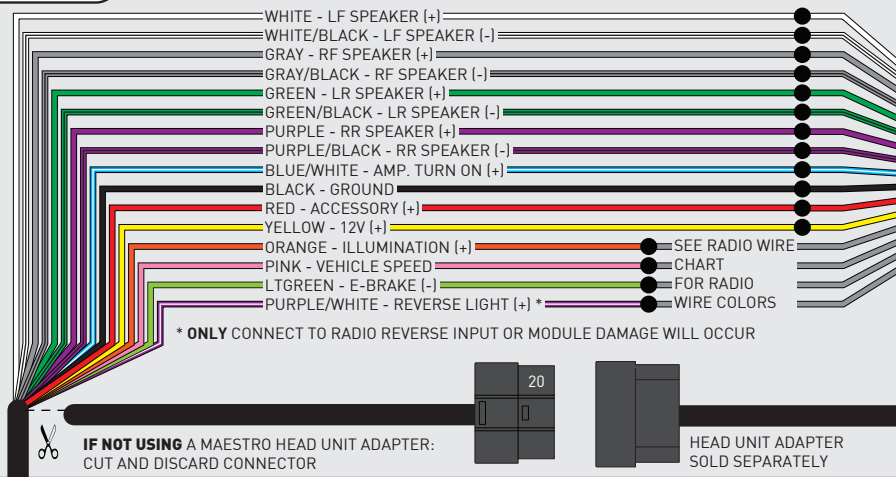

STEP 4

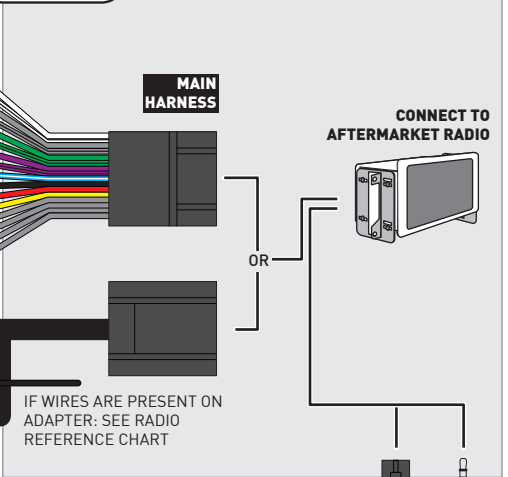

STEP 2

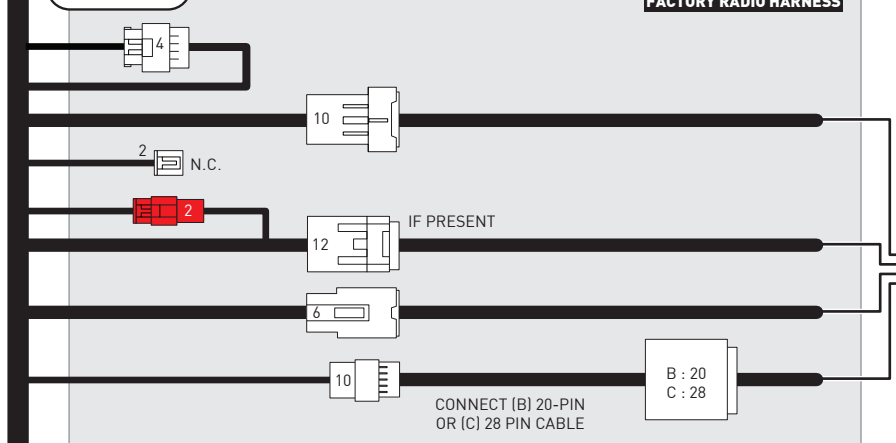

STEP 3

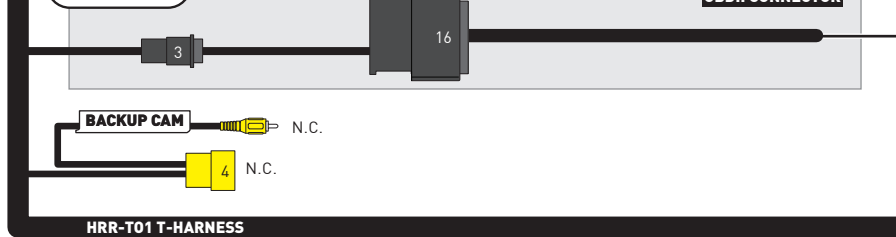

STEP 5

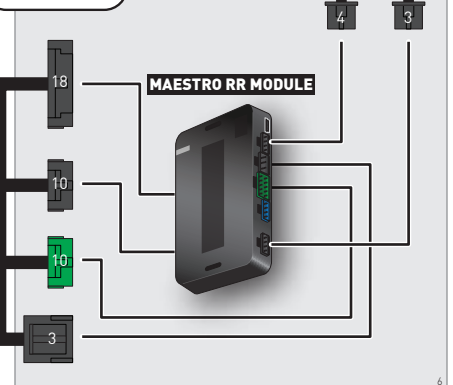

NOT REQUIRED

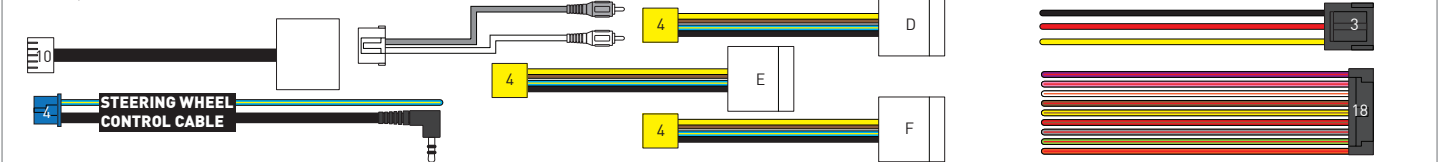

RADIO WIRE REFERENCE CHART

T01 T-harness Wire Description	Polarity	Wire Color on Maestro T-Harness	Wire Color on Alpine cable	Wire Color on Kenwood/JVC cable	Wire Color on Pioneer cable	Wire Color on Sony cable
Illumination	(+)	Orange	N/A	Orange/White	Orange/White	Orange
Reverse Light*	(+)	Purple/White	Orange/White	Purple/White	Purple/White	Purple/White
E-Brake	(-)	Lt Green	Yellow/Blue	Lt Green	Lt Green	Lt Green
VSS (vehicle speed sensor)	(DATA)	Pink	Green/White	Pink	Pink	N/A

Head unit adapter wiring (optional accessory, sold separately)

ACC-HU-ALP1 Wire Description	Polarity	Wire Color on Adapter	Alpine Radio
VSS (vehicle speed sensor)	(DATA)	Green/White	Green/White

ACC-HU-KEN1 Wire Description	Polarity	Wire Color on Adapter	Kenwood Radio
CAM	(+)	Green/Red	Refer to camera/radio manual
CAM	(-)	Green/White	Refer to camera/radio manual
Steering Wheel Controls	(DATA)	Blue/Yellow	n/a

ACC-HU-KEN2 Wire Description	Polarity	Wire Color on Adapter	Kenwood Radio
E-Brake	(-)	LtGreen	LtGreen
Reverse Light*	(+)	Purple/White	Purple/White
Steering Wheel Controls	(DATA)	Blue/Yellow	n/a

* Reverse light wire: Only connect to radio or module damage will occur.

MODULE DIAGNOSTICS



LED 1 Module/Firmware status	LED 2 (RR2) Bluetooth activity	LED STATUS	DIAGNOSTIC
or		RED or GREEN flashing	LED flashes 1 or more times, either red or green, when a steering wheel button is pressed : normal operation.
		1 RED flash	Module has no firmware. Flash module using Weblink Desktop and log in. Do <u>NOT</u> use DEMO MODE.
		2 RED flashes	Problem detected. Consult troubleshooting table.
		1 GREEN flash	After radio boots up : Normal operation.
		3 GREEN flashes	Bluetooth is activated. Turns off after one minute: Normal operation.
		OFF	Normal operation (inactive).

VIDEO HELP		Installation, product information, vehicle specific videos.
VERIFY FLASH		Last flash information, steering control configuration, vehicle information.
WEBLINK		Software to program module.

TROUBLESHOOTING TABLE

PROBLEM	SOLUTION
Gauges do not work, radio shows OBD2 Error 1 or Error 2.	<p>Ensure OBDII connector is securely attached to the OBDII connector of the vehicle.</p> <p>If you hardwired connections at the OBDII, check connections at the OBDII connector. Make sure the RED/BROWN wire is on PIN 6 and the YELLOW/BROWN wire is connected to PIN 14 of the OBDII connector. Do not use T-Taps. Soldering or military splicing methods are recommended.</p> <p>If anything else is connected to the OBD2 or CAN wires of vehicle (programmer, throttle controller, insurance tracker, etc.) try unplugging it to see if gauges work. If gauges work without it installed, call tech support for options.</p> <p>Reset the RR.</p>
The light on the Maestro is blinking RED TWICE and the radio IS turning on.	<p>Ensure the 4-pin data cable is connected between the radio and the RR, and that it is plugged into the black port on the Maestro RR. The red and blue ports on the RR should be empty.</p> <p>Make sure the correct radio model and serial number were entered during the flash. Verify the radio's serial number entered during the flash matches what is listed on the radio screen. This can be found in the settings of the radio, listed as Device Id, Device Number, or Serial Number.</p>
The light on the Maestro is blinking RED TWICE but the radio is NOT turning on.	<p>If installing a modular radio and it is not turning on, ensure the screen is secured and any trim pieces on the radio have been installed fully. Not installing these fully will prevent radio from powering up and show a 2x red error as well.</p> <p>Test red and yellow wires for DC voltage at radio using a multimeter. Contact support if no voltage on red or yellow.</p>
The steering wheel controls are not working, the Maestro RR does not blink when they are pressed.	<p>Ensure the 20 or 28-pin connector is plugged to the vehicle and to the T01 T-harness, as shown in step 3 (this is where the RR gets the steering wheel signal from the vehicle).</p>
(Prius only) After the car is turned off, the radio stays on. The car stays in accessory mode and will not turn off.	<p>Locate the white 12-pin connector of the T01 harness, it is connected to the vehicle harness.</p> <p>Then, cut and isolate the red wire located at pin 11. The radio will shut off when the vehicle is turned off.</p>

MAESTRO RR RESET PROCEDURE:

Turn the key to the OFF position, then disconnect all connectors from the module.

Press and hold the module's programming button and connect all the connectors back to the module. Wait, the module's LED will flash RED rapidly (this may take up to 10 seconds).

Release the programming button. Wait, the LED will turn solid GREEN for 2 seconds to show the reset was successful.

TECHNICAL ASSISTANCE

Phone: 1-866-427-2999

Email: maestro.support@idatalink.com

IMPORTANT: To ensure proper operation, the aftermarket radio needs to have the latest firmware from the manufacturer. Please visit the radio manufacturer's website and look for any updates pertaining to your radio.

RETAINS STEERING WHEEL CONTROLS, FACTORY AMPLIFIER, AND MORE!



PRODUCTS REQUIRED

iDatalink Maestro RR or RR2 Radio Replacement Interface
iDatalink Maestro HRR-T01 Installation Harness

PROGRAMMED FIRMWARE

ADS-RR(SR)-TOY01-DS

ADDITIONAL RESOURCES

[Maestro RR2 Programmable Outputs Guide](#)

OPTIONAL ACCESSORIES

K40[™]
ELECTRONICS
ESCORT

Click here for:
[Radar Installation Guides](#)

HEAD UNIT ADAPTER:
ACC-HU-PI01, SON1, KEN1, KEN2, ALP1

WELCOME

Congratulations on the purchase of your iDatalink Maestro RR Radio replacement solution. You are now a few simple steps away from enjoying your new car radio with enhanced features.

Before starting your installation, please ensure that your iDatalink Maestro module is programmed with the correct firmware for your vehicle and that you carefully review the install guide.

Please note that Maestro RR will only retain functionalities that were originally available in the vehicle.

TABLE OF CONTENTS

Installation Instructions	3
Wiring Diagram	4
Radio Wire Reference Chart	5
Module Diagnostics	6
Troubleshooting Table	7

NEED HELP?

 1 866 427-2999

 maestro.support@idatalink.com

INSTALLATION INSTRUCTIONS P1/1

STEP 1

Remove the factory radio

If using head unit adapter (sold separately), connect HRR-T01 harness to adapter and skip to step 2.

- Unbox the aftermarket radio and locate its main harness.
- Cut and remove the black 20 pin connector from the HRR-T01 T-harness and connect the wires, shown in the wiring diagram, from aftermarket radio main harness to the HRR-T01 T-harness and match the wire functions.

Note: only connect purple/white wire to radio reverse input or module damage will occur.

STEP 2

- If the vehicle is equipped with an OEM backup camera, connect the HRR-T01 harness to appropriate HRR adapter cable (D, E or F) then connect to the backup camera harness.

STEP 3

- Identify if your vehicle has a 20 or 28 pin secondary connector.
- Assemble T01 T-harness as shown on wiring diagram.
- Connect the factory harness to the HRR-T01 harness.

STEP 4

- Connect HRR-T01 3-pin black connector to black connector of OBDII extension harness.
- Plug the OBDII connector into the OBDII of the vehicle.

STEP 5

- Plug the harnesses into the aftermarket radio.
- Connect the backup camera RCA cable into the aftermarket radio (if equipped).
- Plug the Data cable to the data port of the aftermarket radio.
- Insert the Audio cable into the iDatalink 3.5 mm audio jack of the aftermarket radio (if there is no iDatalink audio input, connect to AUX).

Note: On Pioneer radio, ensure that there is nothing plugged into the W/R port.

STEP 6

- Connect all the harnesses to the Maestro RR module then test your installation.

WIRING DIAGRAM *without an Amplifier*

STEP 1

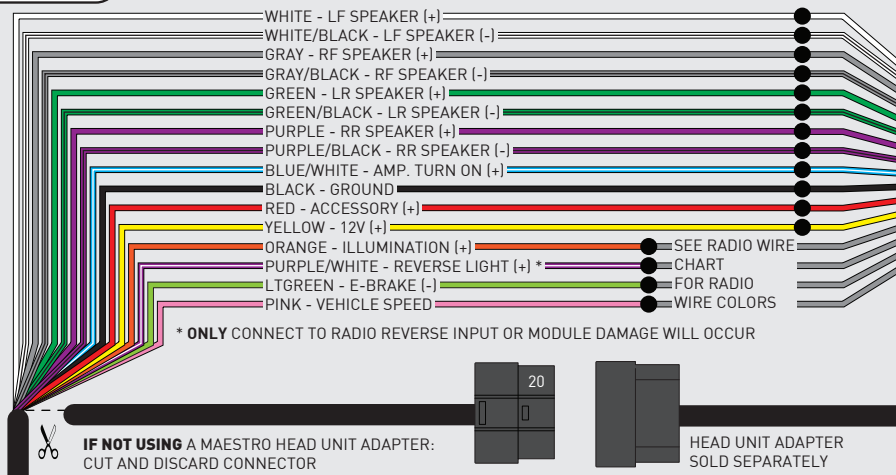

STEP 5

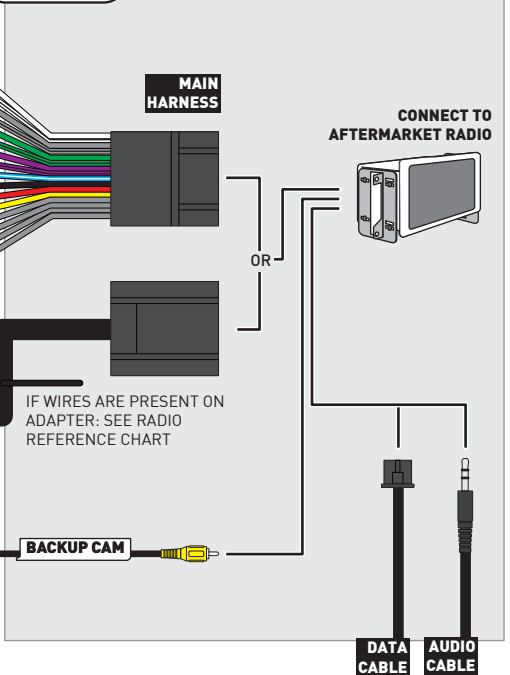

STEP 2

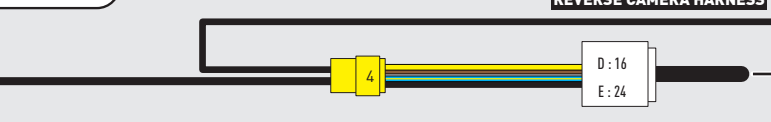

STEP 3

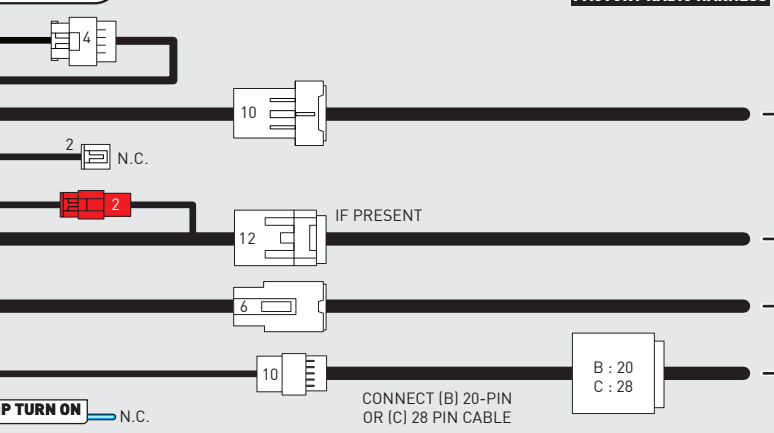

STEP 4



STEP 6

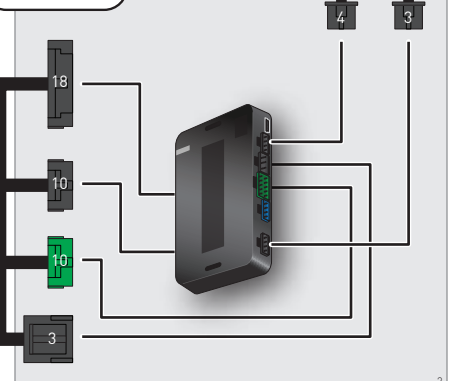

NOT REQUIRED

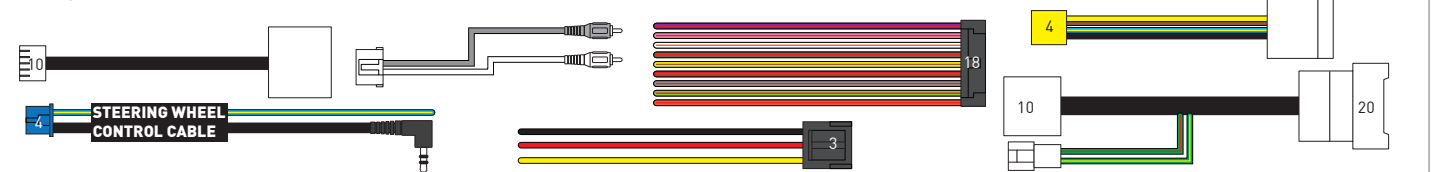

RADIO WIRE REFERENCE CHART

T01 T-harness Wire Description	Polarity	Wire Color on Maestro T-Harness	Wire Color on Alpine cable	Wire Color on Kenwood/JVC cable	Wire Color on Pioneer cable	Wire Color on Sony cable
Illumination	(+)	Orange	N/A	Orange/White	Orange/White	Orange
Reverse Light*	(+)	Purple/White	Orange/White	Purple/White	Purple/White	Purple/White
E-Brake	(-)	Lt Green	Yellow/Blue	Lt Green	Lt Green	Lt Green
VSS (vehicle speed sensor)	(DATA)	Pink	Green/White	Pink	Pink	N/A

Head unit adapter wiring (optional accessory, sold separately)

ACC-HU-ALP1 Wire Description	Polarity	Wire Color on Adapter	Alpine Radio
VSS (vehicle speed sensor)	(DATA)	Green/White	Green/White









ACC-HU-KEN1 Wire Description	Polarity	Wire Color on Adapter	Kenwood Radio
CAM	(+)	Green/Red	Refer to camera/radio manual
CAM	(-)	Green/White	Refer to camera/radio manual
Steering Wheel Controls	(DATA)	Blue/Yellow	n/a

ACC-HU-KEN2 Wire Description	Polarity	Wire Color on Adapter	Kenwood Radio
E-Brake	(-)	LtGreen	LtGreen
Reverse Light*	(+)	Purple/White	Purple/White
Steering Wheel Controls	(DATA)	Blue/Yellow	n/a

* Reverse light wire: Only connect to radio or module damage will occur.

MODULE DIAGNOSTICS



LED 1 Module/Firmware status	LED 2 (RR2) Bluetooth activity	LED STATUS	DIAGNOSTIC
 or 		RED or GREEN flashing	LED flashes 1 or more times, either red or green, when a steering wheel button is pressed : normal operation.
		1 RED flash	Module has no firmware. Flash module using Weblink Desktop and log in. Do <u>NOT</u> use DEMO MODE.
		2 RED flashes	Problem detected. Consult troubleshooting table.
		1 GREEN flash	After radio boots up : Normal operation.
		3 GREEN flashes	Bluetooth is activated. Turns off after one minute: Normal operation.
		OFF	Normal operation (inactive).

VIDEO HELP		Installation, product information, vehicle specific videos.
VERIFY FLASH		Last flash information, steering control configuration, vehicle information.
WEBLINK		Software to program module.

TROUBLESHOOTING TABLE

PROBLEM	SOLUTION
Gauges do not work, radio shows OBD2 Error 1 or Error 2.	<p>Ensure OBDII connector is securely attached to the OBDII connector of the vehicle.</p> <p>If you hardwired connections at the OBDII, check connections at the OBDII connector. Make sure the RED/BROWN wire is on PIN 6 and the YELLOW/BROWN wire is connected to PIN 14 of the OBDII connector. Do not use T-Taps. Soldering or military splicing methods are recommended.</p> <p>If anything else is connected to the OBD2 or CAN wires of vehicle (programmer, throttle controller, insurance tracker, etc.) try unplugging it to see if gauges work. If gauges work without it installed, call tech support for options.</p> <p>Reset the RR.</p>
The light on the Maestro is blinking RED TWICE and the radio IS turning on.	<p>Ensure the 4-pin data cable is connected between the radio and the RR, and that it is plugged into the black port on the Maestro RR. The red and blue ports on the RR should be empty.</p> <p>Make sure the correct radio model and serial number were entered during the flash. Verify the radio's serial number entered during the flash matches what is listed on the radio screen. This can be found in the settings of the radio, listed as Device Id, Device Number, or Serial Number.</p>
The light on the Maestro is blinking RED TWICE but the radio is NOT turning on.	<p>If installing a modular radio and it is not turning on, ensure the screen is secured and any trim pieces on the radio have been installed fully. Not installing these fully will prevent radio from powering up and show a 2x red error as well.</p> <p>Test red and yellow wires for DC voltage at radio using a multimeter. Contact support if no voltage on red or yellow.</p>
The steering wheel controls are not working, the Maestro RR does not blink when they are pressed.	<p>Ensure the 20 or 28-pin connector is plugged to the vehicle and to the T01 T-harness, as shown in step 3 (this is where the RR gets the steering wheel signal from the vehicle).</p>
(Prius only) After the car is turned off, the radio stays on. The car stays in accessory mode and will not turn off.	<p>Locate the white 12-pin connector of the T01 harness, it is connected to the vehicle harness.</p> <p>Then, cut and isolate the red wire located at pin 11. The radio will shut off when the vehicle is turned off.</p>

MAESTRO RR RESET PROCEDURE:

Turn the key to the OFF position, then disconnect all connectors from the module.

Press and hold the module's programming button and connect all the connectors back to the module. Wait, the module's LED will flash RED rapidly (this may take up to 10 seconds).

Release the programming button. Wait, the LED will turn solid GREEN for 2 seconds to show the reset was successful.

TECHNICAL ASSISTANCE

Phone: 1-866-427-2999

Email: maestro.support@idatalink.com

IMPORTANT: To ensure proper operation, the aftermarket radio needs to have the latest firmware from the manufacturer. Please visit the radio manufacturer's website and look for any updates pertaining to your radio.

RETAINS STEERING WHEEL CONTROLS, FACTORY AMPLIFIER, AND MORE!



PRODUCTS REQUIRED

iDatalink Maestro RR or RR2 Radio Replacement Interface
iDatalink Maestro HRR-T01 Installation Harness

PROGRAMMED FIRMWARE

ADS-RR(SR)-TOY01-DS

ADDITIONAL RESOURCES

[Maestro RR2 Programmable Outputs Guide](#)

OPTIONAL ACCESSORIES

K40[™]
ELECTRONICS
ESCORT

Click here for:
[Radar Installation Guides](#)

HEAD UNIT ADAPTER:
ACC-HU-PI01, SON1, KEN1, KEN2, ALP1

WELCOME

Congratulations on the purchase of your iDatalink Maestro RR Radio replacement solution. You are now a few simple steps away from enjoying your new car radio with enhanced features.

Before starting your installation, please ensure that your iDatalink Maestro module is programmed with the correct firmware for your vehicle and that you carefully review the install guide.

Please note that Maestro RR will only retain functionalities that were originally available in the vehicle.

TABLE OF CONTENTS

Installation Instructions	3
Wiring Diagram	4
Radio Wire Reference Chart	5
Module Diagnostics	6
Troubleshooting Table	7

NEED HELP?

 1 866 427-2999

 maestro.support@idatalink.com

INSTALLATION INSTRUCTIONS P1/1

STEP 1

Remove the factory radio

If using head unit adapter (sold separately), connect HRR-T01 harness to adapter and skip to step 2.

- Unbox the aftermarket radio and locate its main harness.
- Cut and remove the black 20 pin connector from the HRR-T01 T-harness and connect the wires, shown in the wiring diagram, from aftermarket radio main harness to the HRR-T01 T-harness and match the wire functions.

Note: only connect purple/white wire to radio reverse input or module damage will occur.

STEP 2

- If the vehicle is equipped with an OEM backup camera, connect the HRR-T01 harness to appropriate HRR adapter cable (D, E or F) then connect to the backup camera harness.

STEP 3

- Identify if your vehicle has a 20 or 28 pin secondary connector.
- Assemble T01 T-harness as shown on wiring diagram.
- Connect the factory harness to the HRR-T01 harness.

STEP 4

- Connect HRR-T01 3-pin black connector to black connector of OBDII extension harness.
- Plug the OBDII connector into the OBDII of the vehicle.

STEP 5

- Plug the harnesses into the aftermarket radio.
- Connect the backup camera RCA cable into the aftermarket radio (if equipped).
- Connect the left front and right front low level outputs RCA cables into the aftermarket radio.
- Plug the Data cable to the data port of the aftermarket radio.
- Insert the Audio cable into the iDatalink 3.5 mm audio jack of the aftermarket radio (if there is no iDatalink audio input, connect to AUX).

Note: On Pioneer radio, ensure that there is nothing plugged into the W/R port.

STEP 6

- Connect all the harnesses to the Maestro RR module then test your installation.

WIRING DIAGRAM *with an Amplifier*

STEP 1

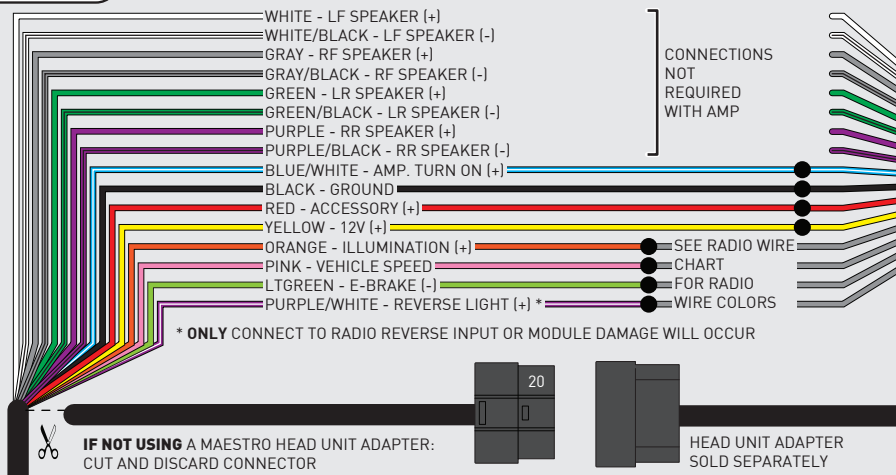

STEP 5

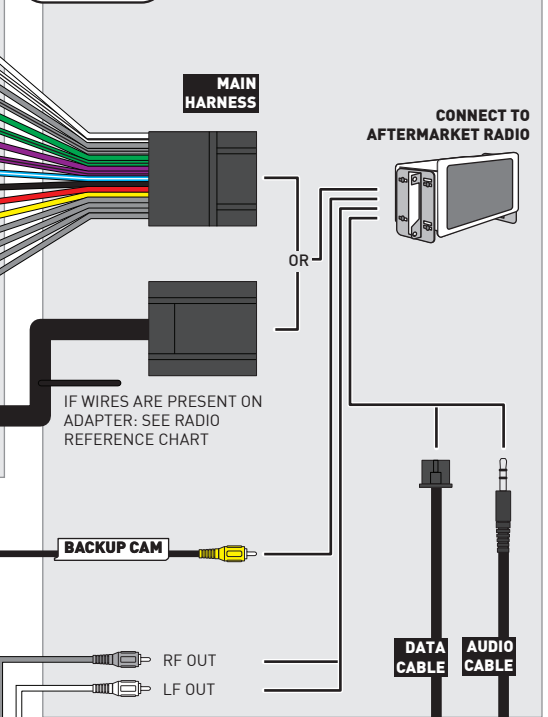

STEP 2

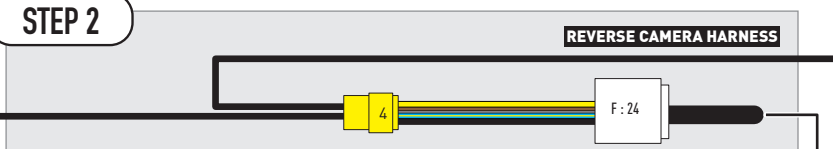

STEP 3

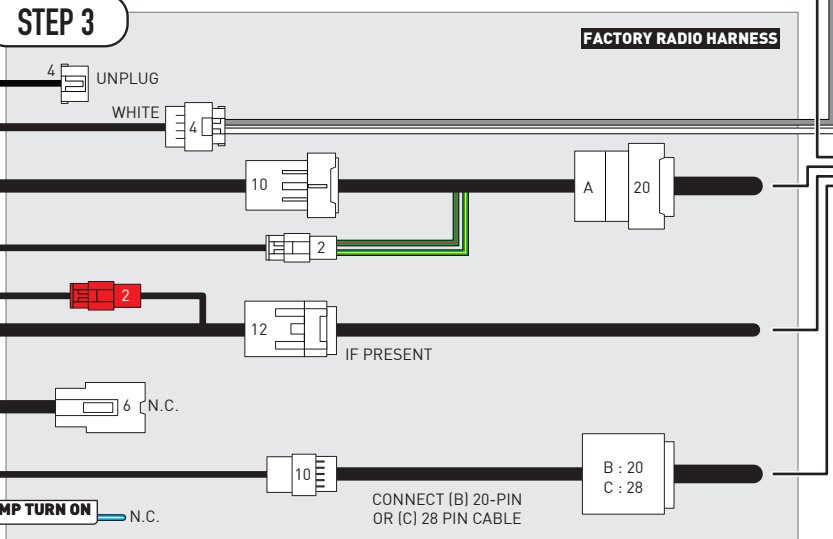

STEP 4

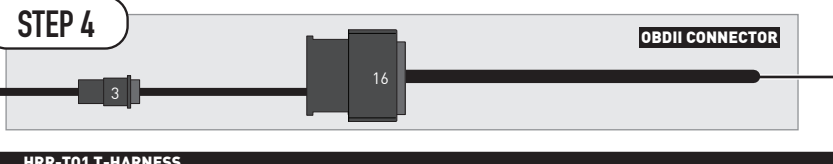

STEP 6

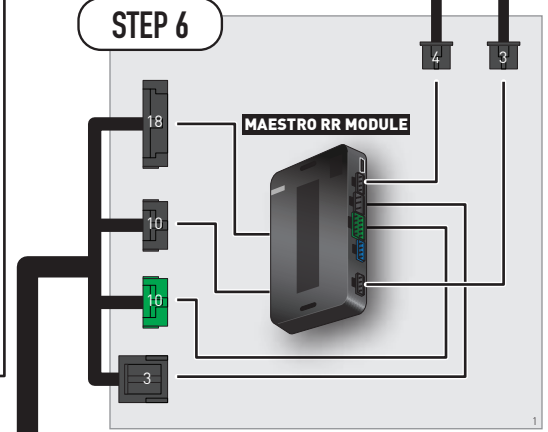

NOT REQUIRED

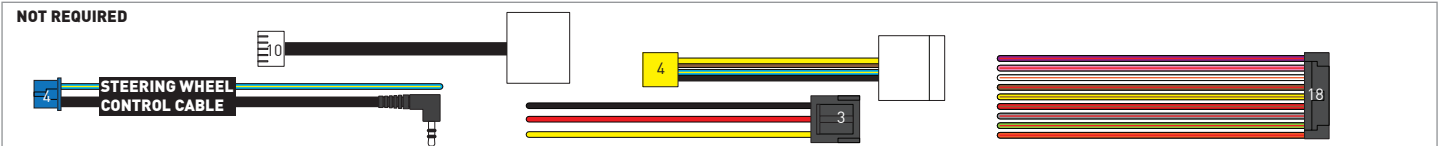

RADIO WIRE REFERENCE CHART

T01 T-harness Wire Description	Polarity	Wire Color on Maestro T-Harness	Wire Color on Alpine cable	Wire Color on Kenwood/JVC cable	Wire Color on Pioneer cable	Wire Color on Sony cable
Illumination	(+)	Orange	N/A	Orange/White	Orange/White	Orange
Reverse Light*	(+)	Purple/White	Orange/White	Purple/White	Purple/White	Purple/White
E-Brake	(-)	Lt Green	Yellow/Blue	Lt Green	Lt Green	Lt Green
VSS (vehicle speed sensor)	(DATA)	Pink	Green/White	Pink	Pink	N/A

Head unit adapter wiring (optional accessory, sold separately)

ACC-HU-ALP1 Wire Description	Polarity	Wire Color on Adapter	Alpine Radio
VSS (vehicle speed sensor)	(DATA)	Green/White	Green/White

ACC-HU-KEN1 Wire Description	Polarity	Wire Color on Adapter	Kenwood Radio
CAM	(+)	Green/Red	Refer to camera/radio manual
CAM	(-)	Green/White	Refer to camera/radio manual
Steering Wheel Controls	(DATA)	Blue/Yellow	n/a

ACC-HU-KEN2 Wire Description	Polarity	Wire Color on Adapter	Kenwood Radio
E-Brake	(-)	LtGreen	LtGreen
Reverse Light*	(+)	Purple/White	Purple/White
Steering Wheel Controls	(DATA)	Blue/Yellow	n/a

* Reverse light wire: Only connect to radio or module damage will occur.

MODULE DIAGNOSTICS



LED 1 Module/Firmware status	LED 2 (RR2) Bluetooth activity	LED STATUS	DIAGNOSTIC
or		RED or GREEN flashing	LED flashes 1 or more times, either red or green, when a steering wheel button is pressed : normal operation.
		1 RED flash	Module has no firmware. Flash module using Weblink Desktop and log in. Do <u>NOT</u> use DEMO MODE.
		2 RED flashes	Problem detected. Consult troubleshooting table.
		1 GREEN flash	After radio boots up : Normal operation.
		3 GREEN flashes	Bluetooth is activated. Turns off after one minute: Normal operation.
		OFF	Normal operation (inactive).

VIDEO HELP		Installation, product information, vehicle specific videos.
VERIFY FLASH		Last flash information, steering control configuration, vehicle information.
WEBLINK		Software to program module.

TROUBLESHOOTING TABLE

PROBLEM	SOLUTION
Gauges do not work, radio shows OBD2 Error 1 or Error 2.	<p>Ensure OBDII connector is securely attached to the OBDII connector of the vehicle.</p> <p>If you hardwired connections at the OBDII, check connections at the OBDII connector. Make sure the RED/BROWN wire is on PIN 6 and the YELLOW/BROWN wire is connected to PIN 14 of the OBDII connector. Do not use T-Taps. Soldering or military splicing methods are recommended.</p> <p>If anything else is connected to the OBD2 or CAN wires of vehicle (programmer, throttle controller, insurance tracker, etc.) try unplugging it to see if gauges work. If gauges work without it installed, call tech support for options.</p> <p>Reset the RR.</p>
The light on the Maestro is blinking RED TWICE and the radio IS turning on.	<p>Ensure the 4-pin data cable is connected between the radio and the RR, and that it is plugged into the black port on the Maestro RR. The red and blue ports on the RR should be empty.</p> <p>Make sure the correct radio model and serial number were entered during the flash. Verify the radio's serial number entered during the flash matches what is listed on the radio screen. This can be found in the settings of the radio, listed as Device Id, Device Number, or Serial Number.</p>
The light on the Maestro is blinking RED TWICE but the radio is NOT turning on.	<p>If installing a modular radio and it is not turning on, ensure the screen is secured and any trim pieces on the radio have been installed fully. Not installing these fully will prevent radio from powering up and show a 2x red error as well.</p> <p>Test red and yellow wires for DC voltage at radio using a multimeter. Contact support if no voltage on red or yellow.</p>
The steering wheel controls are not working, the Maestro RR does not blink when they are pressed.	<p>Ensure the 20 or 28-pin connector is plugged to the vehicle and to the T01 T-harness, as shown in step 3 (this is where the RR gets the steering wheel signal from the vehicle).</p>
(Prius only) After the car is turned off, the radio stays on. The car stays in accessory mode and will not turn off.	<p>Locate the white 12-pin connector of the T01 harness, it is connected to the vehicle harness.</p> <p>Then, cut and isolate the red wire located at pin 11. The radio will shut off when the vehicle is turned off.</p>

MAESTRO RR RESET PROCEDURE:

Turn the key to the OFF position, then disconnect all connectors from the module.

Press and hold the module's programming button and connect all the connectors back to the module. Wait, the module's LED will flash RED rapidly (this may take up to 10 seconds).

Release the programming button. Wait, the LED will turn solid GREEN for 2 seconds to show the reset was successful.

TECHNICAL ASSISTANCE

Phone: 1-866-427-2999

Email: maestro.support@idatalink.com

IMPORTANT: To ensure proper operation, the aftermarket radio needs to have the latest firmware from the manufacturer. Please visit the radio manufacturer's website and look for any updates pertaining to your radio.

RETAINS STEERING WHEEL CONTROLS, FACTORY AMPLIFIER, AND MORE!



PRODUCTS REQUIRED

iDatalink Maestro RR or RR2 Radio Replacement Interface
iDatalink Maestro HRR-T01 Installation Harness

PROGRAMMED FIRMWARE

ADS-RR(SR)-TOY01-DS

ADDITIONAL RESOURCES

[Maestro RR2 Programmable Outputs Guide](#)

OPTIONAL ACCESSORIES



Click here for:
[Radar Installation Guides](#)

HEAD UNIT ADAPTER:
ACC-HU-PI01, SON1, KEN1, KEN2, ALP1

WELCOME

Congratulations on the purchase of your iDatalink Maestro RR Radio replacement solution. You are now a few simple steps away from enjoying your new car radio with enhanced features.

Before starting your installation, please ensure that your iDatalink Maestro module is programmed with the correct firmware for your vehicle and that you carefully review the install guide.

Please note that Maestro RR will only retain functionalities that were originally available in the vehicle.

TABLE OF CONTENTS

Installation Instructions	3
Wiring Diagram	4
Radio Wire Reference Chart	5
Module Diagnostics	6
Troubleshooting Table	7

NEED HELP?

 1 866 427-2999

 maestro.support@idatalink.com

INSTALLATION INSTRUCTIONS P1/1

STEP 1

Remove the factory radio

If using head unit adapter (sold separately), connect HRR-T01 harness to adapter and skip to step 2.

- Unbox the aftermarket radio and locate its main harness.
- Cut and remove the black 20 pin connector from the HRR-T01 T-harness and connect the wires, shown in the wiring diagram, from aftermarket radio main harness to the HRR-T01 T-harness and match the wire functions.

Note: only connect purple/white wire to radio reverse input or module damage will occur.

STEP 2

- If the vehicle is equipped with an OEM backup camera, connect the HRR-T01 harness to any HRR adapter cable (D, E or F) then cut off the 16 or 24-pin connector. Connect the adapter's wires to reverse camera harness, as shown in wiring diagram.
- Assemble T01 T-harness as shown on wiring diagram.
- Connect the factory harness to the HRR-T01 harness.

STEP 3

- Connect HRR-T01 3-pin black connector to black connector of OBDII extension harness.
- Plug the OBDII connector into the OBDII of the vehicle.

STEP 4

- Plug the harnesses into the aftermarket radio.
- Connect the backup camera RCA cable into the aftermarket radio (if equipped).
- Plug the Data cable to the data port of the aftermarket radio.
- Insert the Audio cable into the iDatalink 3.5 mm audio jack of the aftermarket radio (if there is no iDatalink audio input, connect to AUX).

Note: On Pioneer radio, ensure that there is nothing plugged into the W/R port.

STEP 5

- Connect all the harnesses to the Maestro RR module then test your installation.

WIRING DIAGRAM *without an Amplifier*

STEP 1

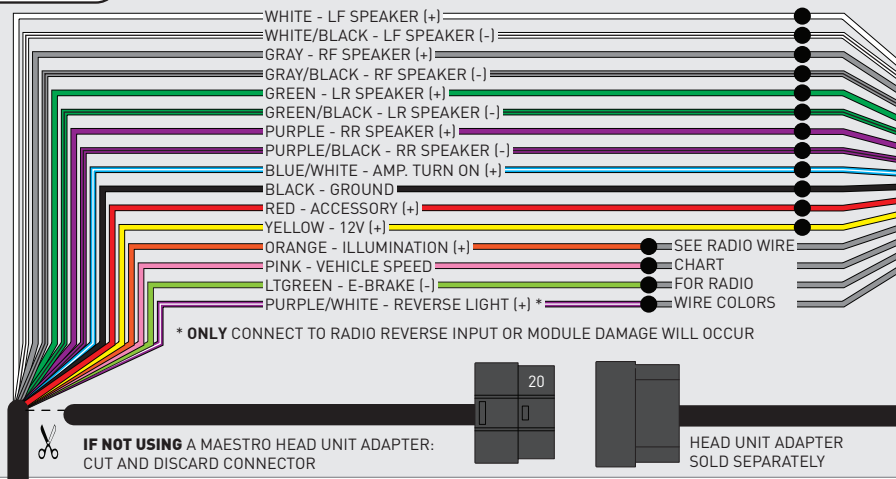

STEP 4

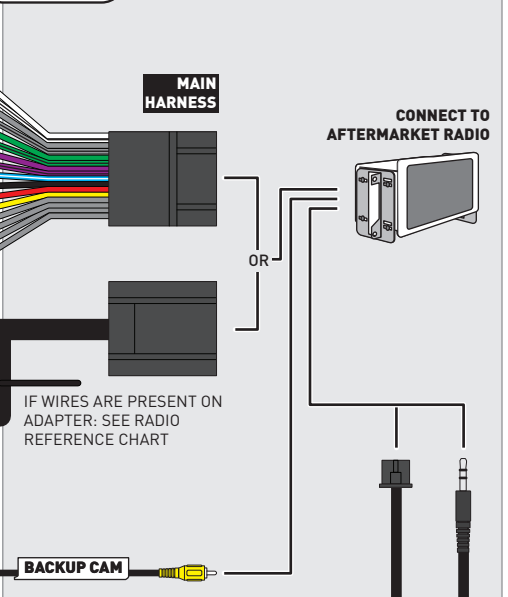

STEP 2

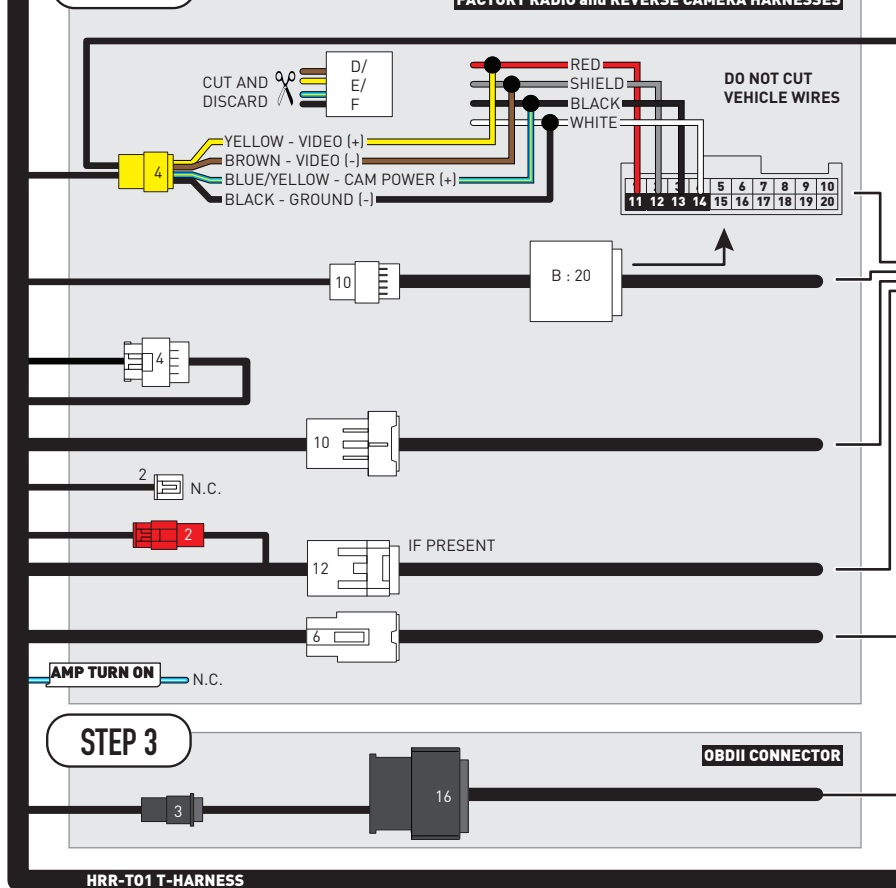

STEP 3

STEP 5

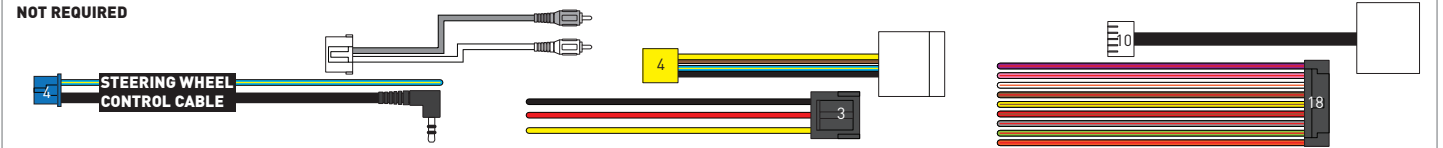
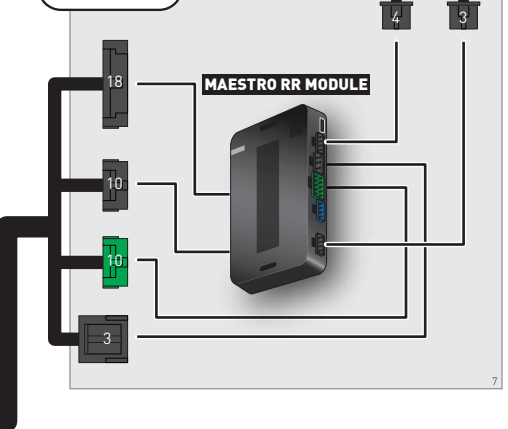

RADIO WIRE REFERENCE CHART

T01 T-harness Wire Description	Polarity	Wire Color on Maestro T-Harness	Wire Color on Alpine cable	Wire Color on Kenwood/JVC cable	Wire Color on Pioneer cable	Wire Color on Sony cable
Illumination	(+)	Orange	N/A	Orange/White	Orange/White	Orange
Reverse Light*	(+)	Purple/White	Orange/White	Purple/White	Purple/White	Purple/White
E-Brake	(-)	Lt Green	Yellow/Blue	Lt Green	Lt Green	Lt Green
VSS (vehicle speed sensor)	(DATA)	Pink	Green/White	Pink	Pink	N/A

Head unit adapter wiring (optional accessory, sold separately)

ACC-HU-ALP1 Wire Description	Polarity	Wire Color on Adapter	Alpine Radio
VSS (vehicle speed sensor)	(DATA)	Green/White	Green/White

ACC-HU-KEN1 Wire Description	Polarity	Wire Color on Adapter	Kenwood Radio
CAM	(+)	Green/Red	Refer to camera/radio manual
CAM	(-)	Green/White	Refer to camera/radio manual
Steering Wheel Controls	(DATA)	Blue/Yellow	n/a

ACC-HU-KEN2 Wire Description	Polarity	Wire Color on Adapter	Kenwood Radio
E-Brake	(-)	LtGreen	LtGreen
Reverse Light*	(+)	Purple/White	Purple/White
Steering Wheel Controls	(DATA)	Blue/Yellow	n/a

* Reverse light wire: Only connect to radio or module damage will occur.

MODULE DIAGNOSTICS



LED 1 Module/Firmware status	LED 2 (RR2) Bluetooth activity	LED STATUS	DIAGNOSTIC
or		RED or GREEN flashing	LED flashes 1 or more times, either red or green, when a steering wheel button is pressed : normal operation.
		1 RED flash	Module has no firmware. Flash module using Weblink Desktop and log in. Do <u>NOT</u> use DEMO MODE.
		2 RED flashes	Problem detected. Consult troubleshooting table.
		1 GREEN flash	After radio boots up : Normal operation.
		3 GREEN flashes	Bluetooth is activated. Turns off after one minute: Normal operation.
		OFF	Normal operation (inactive).

VIDEO HELP		Installation, product information, vehicle specific videos.
VERIFY FLASH		Last flash information, steering control configuration, vehicle information.
WEBLINK		Software to program module.

TROUBLESHOOTING TABLE

PROBLEM	SOLUTION
Gauges do not work, radio shows OBD2 Error 1 or Error 2.	<p>Ensure OBDII connector is securely attached to the OBDII connector of the vehicle.</p> <p>If you hardwired connections at the OBDII, check connections at the OBDII connector. Make sure the RED/BROWN wire is on PIN 6 and the YELLOW/BROWN wire is connected to PIN 14 of the OBDII connector. Do not use T-Taps. Soldering or military splicing methods are recommended.</p> <p>If anything else is connected to the OBD2 or CAN wires of vehicle (programmer, throttle controller, insurance tracker, etc.) try unplugging it to see if gauges work. If gauges work without it installed, call tech support for options.</p> <p>Reset the RR.</p>
The light on the Maestro is blinking RED TWICE and the radio IS turning on.	<p>Ensure the 4-pin data cable is connected between the radio and the RR, and that it is plugged into the black port on the Maestro RR. The red and blue ports on the RR should be empty.</p> <p>Make sure the correct radio model and serial number were entered during the flash. Verify the radio's serial number entered during the flash matches what is listed on the radio screen. This can be found in the settings of the radio, listed as Device Id, Device Number, or Serial Number.</p>
The light on the Maestro is blinking RED TWICE but the radio is NOT turning on.	<p>If installing a modular radio and it is not turning on, ensure the screen is secured and any trim pieces on the radio have been installed fully. Not installing these fully will prevent radio from powering up and show a 2x red error as well.</p> <p>Test red and yellow wires for DC voltage at radio using a multimeter. Contact support if no voltage on red or yellow.</p>
The steering wheel controls are not working, the Maestro RR does not blink when they are pressed.	<p>Ensure the 20 or 28-pin connector is plugged to the vehicle and to the T01 T-harness, as shown in step 3 (this is where the RR gets the steering wheel signal from the vehicle).</p>
(Prius only) After the car is turned off, the radio stays on. The car stays in accessory mode and will not turn off.	<p>Locate the white 12-pin connector of the T01 harness, it is connected to the vehicle harness.</p> <p>Then, cut and isolate the red wire located at pin 11. The radio will shut off when the vehicle is turned off.</p>

MAESTRO RR RESET PROCEDURE:

Turn the key to the OFF position, then disconnect all connectors from the module.

Press and hold the module's programming button and connect all the connectors back to the module. Wait, the module's LED will flash RED rapidly (this may take up to 10 seconds).

Release the programming button. Wait, the LED will turn solid GREEN for 2 seconds to show the reset was successful.

TECHNICAL ASSISTANCE

Phone: 1-866-427-2999

Email: maestro.support@idatalink.com

IMPORTANT: To ensure proper operation, the aftermarket radio needs to have the latest firmware from the manufacturer. Please visit the radio manufacturer's website and look for any updates pertaining to your radio.

RETAINS STEERING WHEEL CONTROLS, FACTORY AMPLIFIER, AND MORE!



PRODUCTS REQUIRED

iDatalink Maestro RR or RR2 Radio Replacement Interface
iDatalink Maestro HRR-T01 Installation Harness

PROGRAMMED FIRMWARE

ADS-RR(SR)-TOY01-DS

ADDITIONAL RESOURCES

[Maestro RR2 Programmable Outputs Guide](#)

OPTIONAL ACCESSORIES



Click here for:
[Radar Installation Guides](#)

HEAD UNIT ADAPTER:
ACC-HU-PI01, SON1, KEN1, KEN2, ALP1

WELCOME

Congratulations on the purchase of your iDatalink Maestro RR Radio replacement solution. You are now a few simple steps away from enjoying your new car radio with enhanced features.

Before starting your installation, please ensure that your iDatalink Maestro module is programmed with the correct firmware for your vehicle and that you carefully review the install guide.

Please note that Maestro RR will only retain functionalities that were originally available in the vehicle.

TABLE OF CONTENTS

Installation Instructions	3
Wiring Diagram	4
Radio Wire Reference Chart	5
Module Diagnostics	6
Troubleshooting Table	7

NEED HELP?

 1 866 427-2999

 maestro.support@idatalink.com

INSTALLATION INSTRUCTIONS P1/1

STEP 1

Remove the factory radio

If using head unit adapter (sold separately), connect HRR-T01 harness to adapter and skip to step 2.

- Unbox the aftermarket radio and locate its main harness.
- Cut and remove the black 20 pin connector from the HRR-T01 T-harness and connect the wires, shown in the wiring diagram, from aftermarket radio main harness to the HRR-T01 T-harness and match the wire functions.

Note: only connect purple/white wire to radio reverse input or module damage will occur.

STEP 2

- If the vehicle is equipped with an OEM backup camera, connect the HRR-T01 harness to appropriate HRR adapter cable (D, E or F) then connect to the backup camera harness.

STEP 3

- Identify if your vehicle has a 20 or 28 pin secondary connector.
- Assemble T01 T-harness as shown on wiring diagram.
- Connect the factory harness to the HRR-T01 harness.

STEP 4

- Connect HRR-T01 3-pin black connector to black connector of OBDII extension harness.
- Plug the OBDII connector into the OBDII of the vehicle.

STEP 5

- Plug the harnesses into the aftermarket radio.
- Connect the backup camera RCA cable into the aftermarket radio (if equipped).
- Connect the left front and right front low level outputs RCA cables into the aftermarket radio.
- Plug the Data cable to the data port of the aftermarket radio.
- Insert the Audio cable into the iDatalink 3.5 mm audio jack of the aftermarket radio (if there is no iDatalink audio input, connect to AUX).

Note: On Pioneer radio, ensure that there is nothing plugged into the W/R port.

STEP 6

- Connect all the harnesses to the Maestro RR module then test your installation.

WIRING DIAGRAM *with an Amplifier*

STEP 1

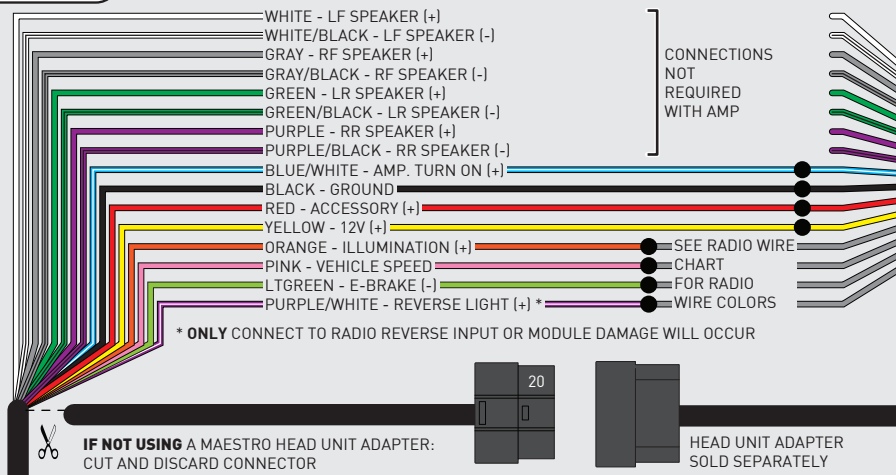

STEP 5

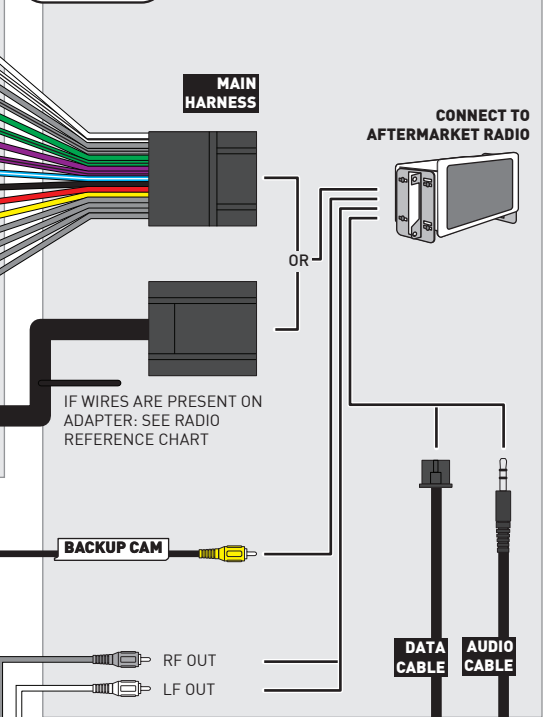

STEP 2

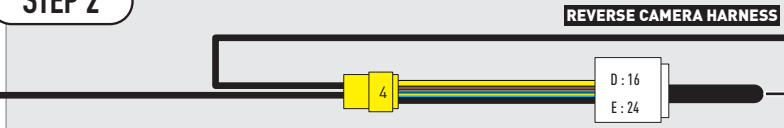

STEP 3

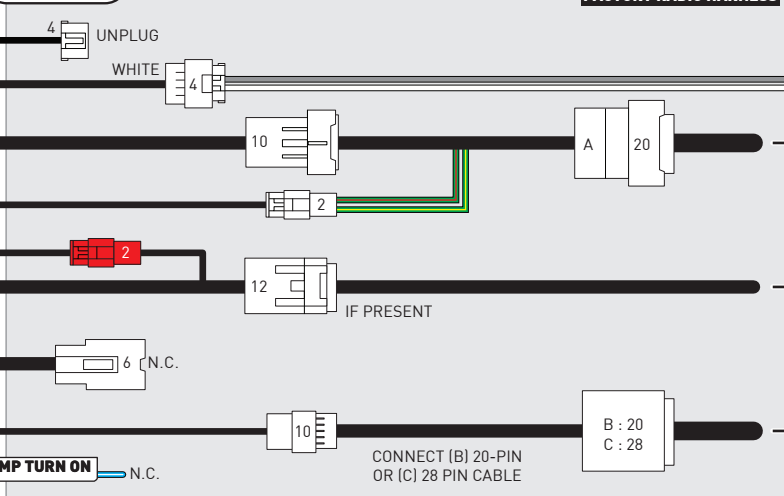

STEP 4

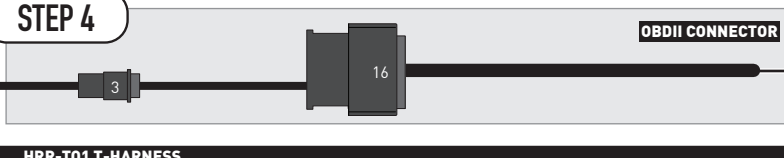

STEP 6

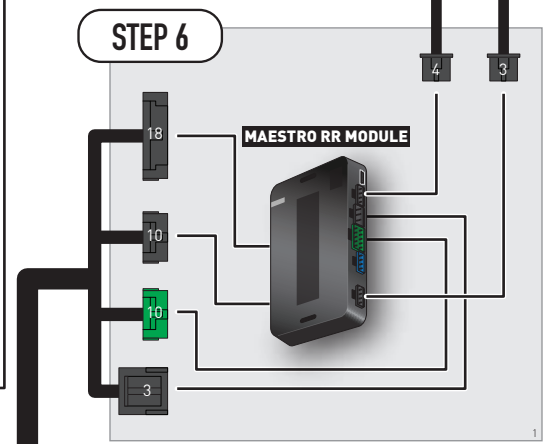

NOT REQUIRED

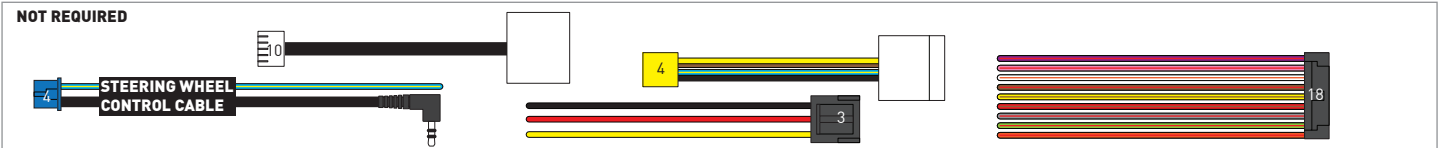

RADIO WIRE REFERENCE CHART

T01 T-harness Wire Description	Polarity	Wire Color on Maestro T-Harness	Wire Color on Alpine cable	Wire Color on Kenwood/JVC cable	Wire Color on Pioneer cable	Wire Color on Sony cable
Illumination	(+)	Orange	N/A	Orange/White	Orange/White	Orange
Reverse Light*	(+)	Purple/White	Orange/White	Purple/White	Purple/White	Purple/White
E-Brake	(-)	Lt Green	Yellow/Blue	Lt Green	Lt Green	Lt Green
VSS (vehicle speed sensor)	(DATA)	Pink	Green/White	Pink	Pink	N/A

Head unit adapter wiring (optional accessory, sold separately)

ACC-HU-ALP1 Wire Description	Polarity	Wire Color on Adapter	Alpine Radio
VSS (vehicle speed sensor)	(DATA)	Green/White	Green/White

ACC-HU-KEN1 Wire Description	Polarity	Wire Color on Adapter	Kenwood Radio
CAM	(+)	Green/Red	Refer to camera/radio manual
CAM	(-)	Green/White	Refer to camera/radio manual
Steering Wheel Controls	(DATA)	Blue/Yellow	n/a

ACC-HU-KEN2 Wire Description	Polarity	Wire Color on Adapter	Kenwood Radio
E-Brake	(-)	LtGreen	LtGreen
Reverse Light*	(+)	Purple/White	Purple/White
Steering Wheel Controls	(DATA)	Blue/Yellow	n/a

* Reverse light wire: Only connect to radio or module damage will occur.

MODULE DIAGNOSTICS



LED 1 Module/Firmware status	LED 2 (RR2) Bluetooth activity	LED STATUS	DIAGNOSTIC
or		RED or GREEN flashing	LED flashes 1 or more times, either red or green, when a steering wheel button is pressed : normal operation.
		1 RED flash	Module has no firmware. Flash module using Weblink Desktop and log in. Do <u>NOT</u> use DEMO MODE.
		2 RED flashes	Problem detected. Consult troubleshooting table.
		1 GREEN flash	After radio boots up : Normal operation.
		3 GREEN flashes	Bluetooth is activated. Turns off after one minute: Normal operation.
		OFF	Normal operation (inactive).

VIDEO HELP		Installation, product information, vehicle specific videos.
VERIFY FLASH		Last flash information, steering control configuration, vehicle information.
WEBLINK		Software to program module.

TROUBLESHOOTING TABLE

PROBLEM	SOLUTION
Gauges do not work, radio shows OBD2 Error 1 or Error 2.	<p>Ensure OBDII connector is securely attached to the OBDII connector of the vehicle.</p> <p>If you hardwired connections at the OBDII, check connections at the OBDII connector. Make sure the RED/BROWN wire is on PIN 6 and the YELLOW/BROWN wire is connected to PIN 14 of the OBDII connector. Do not use T-Taps. Soldering or military splicing methods are recommended.</p> <p>If anything else is connected to the OBD2 or CAN wires of vehicle (programmer, throttle controller, insurance tracker, etc.) try unplugging it to see if gauges work. If gauges work without it installed, call tech support for options.</p> <p>Reset the RR.</p>
The light on the Maestro is blinking RED TWICE and the radio IS turning on.	<p>Ensure the 4-pin data cable is connected between the radio and the RR, and that it is plugged into the black port on the Maestro RR. The red and blue ports on the RR should be empty.</p> <p>Make sure the correct radio model and serial number were entered during the flash. Verify the radio's serial number entered during the flash matches what is listed on the radio screen. This can be found in the settings of the radio, listed as Device Id, Device Number, or Serial Number.</p>
The light on the Maestro is blinking RED TWICE but the radio is NOT turning on.	<p>If installing a modular radio and it is not turning on, ensure the screen is secured and any trim pieces on the radio have been installed fully. Not installing these fully will prevent radio from powering up and show a 2x red error as well.</p> <p>Test red and yellow wires for DC voltage at radio using a multimeter. Contact support if no voltage on red or yellow.</p>
The steering wheel controls are not working, the Maestro RR does not blink when they are pressed.	<p>Ensure the 20 or 28-pin connector is plugged to the vehicle and to the T01 T-harness, as shown in step 3 (this is where the RR gets the steering wheel signal from the vehicle).</p>
(Prius only) After the car is turned off, the radio stays on. The car stays in accessory mode and will not turn off.	<p>Locate the white 12-pin connector of the T01 harness, it is connected to the vehicle harness.</p> <p>Then, cut and isolate the red wire located at pin 11. The radio will shut off when the vehicle is turned off.</p>

MAESTRO RR RESET PROCEDURE:

Turn the key to the OFF position, then disconnect all connectors from the module.

Press and hold the module's programming button and connect all the connectors back to the module. Wait, the module's LED will flash RED rapidly (this may take up to 10 seconds).

Release the programming button. Wait, the LED will turn solid GREEN for 2 seconds to show the reset was successful.

TECHNICAL ASSISTANCE

Phone: 1-866-427-2999

Email: maestro.support@idatalink.com

IMPORTANT: To ensure proper operation, the aftermarket radio needs to have the latest firmware from the manufacturer. Please visit the radio manufacturer's website and look for any updates pertaining to your radio.

RETAINS STEERING WHEEL CONTROLS, FACTORY AMPLIFIER, AND MORE!



PRODUCTS REQUIRED

iDatalink Maestro RR or RR2 Radio Replacement Interface
iDatalink Maestro HRR-T01 Installation Harness

PROGRAMMED FIRMWARE

ADS-RR(SR)-TOY01-DS

ADDITIONAL RESOURCES

[Maestro RR2 Programmable Outputs Guide](#)

OPTIONAL ACCESSORIES

K40[™]
ELECTRONICS
ESCORT

Click here for:
[Radar Installation Guides](#)

HEAD UNIT ADAPTER:
ACC-HU-PI01, SON1, KEN1, KEN2, ALP1

WELCOME

Congratulations on the purchase of your iDatalink Maestro RR Radio replacement solution. You are now a few simple steps away from enjoying your new car radio with enhanced features.

Before starting your installation, please ensure that your iDatalink Maestro module is programmed with the correct firmware for your vehicle and that you carefully review the install guide.

Please note that Maestro RR will only retain functionalities that were originally available in the vehicle.

NEED HELP?

 1 866 427-2999

 maestro.support@idatalink.com

TABLE OF CONTENTS

Installation Instructions	3
Wiring Diagram	4
Radio Wire Reference Chart	5
Module Diagnostics	6
Troubleshooting Table	7

INSTALLATION INSTRUCTIONS P1/1

STEP 1

Remove the factory radio

If using head unit adapter (sold separately), connect HRR-T01 harness to adapter and skip to step 2.

- Unbox the aftermarket radio and locate its main harness.
- Cut and remove the black 20 pin connector from the HRR-T01 T-harness and connect the wires, shown in the wiring diagram, from aftermarket radio main harness to the HRR-T01 T-harness and match the wire functions.

Note: only connect purple/white wire to radio reverse input or module damage will occur.

STEP 2

- If the vehicle is equipped with an OEM backup camera, connect the HRR-T01 harness to appropriate HRR adapter cable (D, E or F) then connect to the backup camera harness.

STEP 3

- Identify if your vehicle has a 20 or 28 pin secondary connector.
- Assemble T01 T-harness as shown on wiring diagram.
- Connect the factory harness to the HRR-T01 harness.

STEP 4

- Connect HRR-T01 3-pin black connector to black connector of OBDII extension harness.
- Plug the OBDII connector into the OBDII of the vehicle.

STEP 5

- Plug the harnesses into the aftermarket radio.
- Connect the backup camera RCA cable into the aftermarket radio (if equipped).
- Connect the left front and right front low level outputs RCA cables into the aftermarket radio.
- Plug the Data cable to the data port of the aftermarket radio.
- Insert the Audio cable into the iDatalink 3.5 mm audio jack of the aftermarket radio (if there is no iDatalink audio input, connect to AUX).

Note: On Pioneer radio, ensure that there is nothing plugged into the W/R port.

STEP 6

- Connect all the harnesses to the Maestro RR module then test your installation.

WIRING DIAGRAM *with an Amplifier*

STEP 1

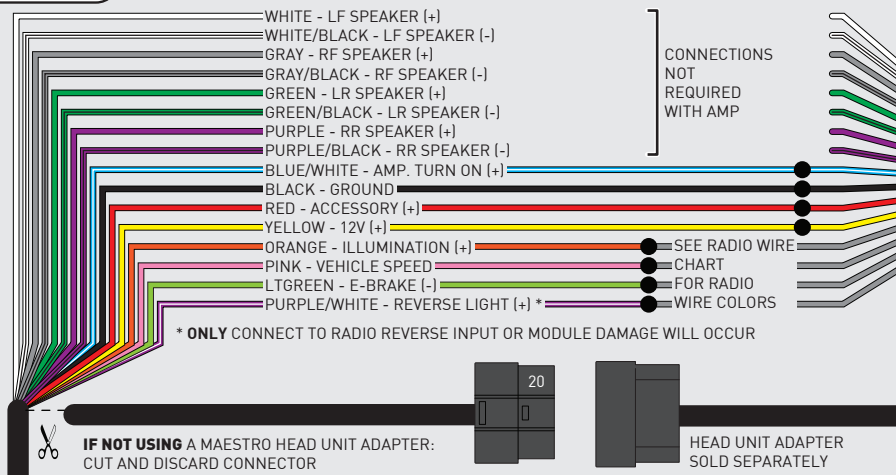

STEP 5

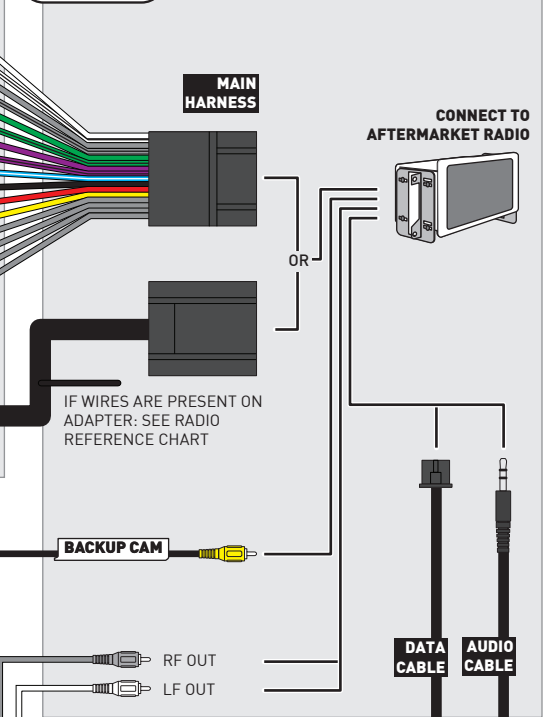

STEP 2

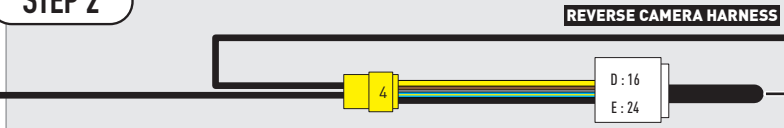

STEP 3

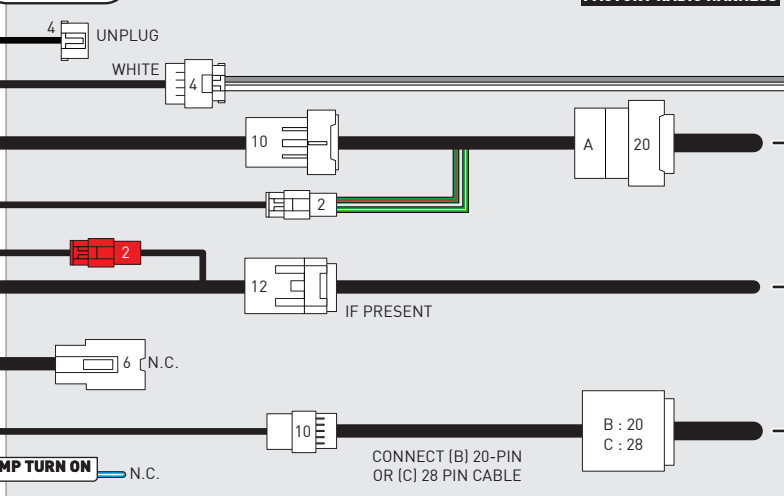

STEP 4

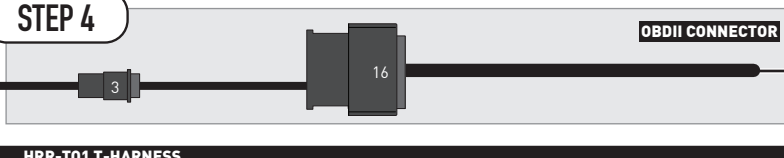

STEP 6

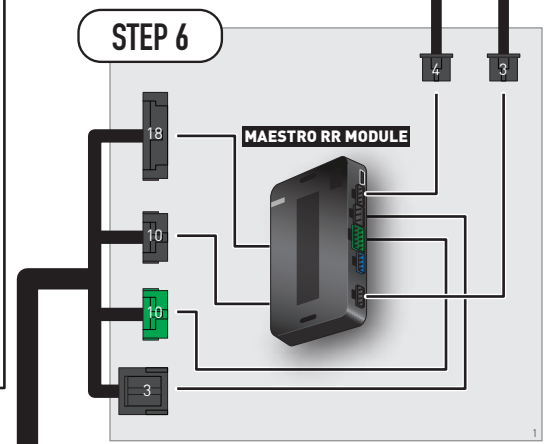

NOT REQUIRED

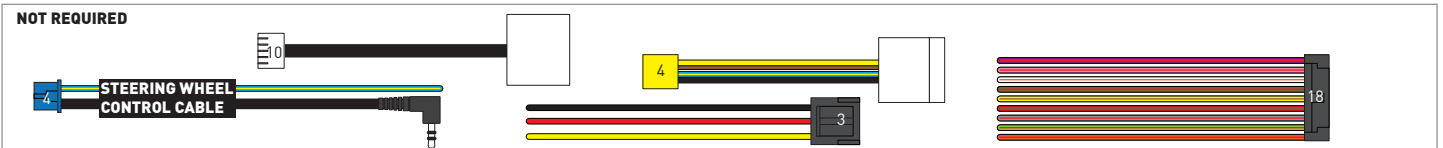

RADIO WIRE REFERENCE CHART

T01 T-harness Wire Description	Polarity	Wire Color on Maestro T-Harness	Wire Color on Alpine cable	Wire Color on Kenwood/JVC cable	Wire Color on Pioneer cable	Wire Color on Sony cable
Illumination	(+)	Orange	N/A	Orange/White	Orange/White	Orange
Reverse Light*	(+)	Purple/White	Orange/White	Purple/White	Purple/White	Purple/White
E-Brake	(-)	Lt Green	Yellow/Blue	Lt Green	Lt Green	Lt Green
VSS (vehicle speed sensor)	(DATA)	Pink	Green/White	Pink	Pink	N/A

Head unit adapter wiring (optional accessory, sold separately)

ACC-HU-ALP1 Wire Description	Polarity	Wire Color on Adapter	Alpine Radio
VSS (vehicle speed sensor)	(DATA)	Green/White	Green/White

ACC-HU-KEN1 Wire Description	Polarity	Wire Color on Adapter	Kenwood Radio
CAM	(+)	Green/Red	Refer to camera/radio manual
CAM	(-)	Green/White	Refer to camera/radio manual
Steering Wheel Controls	(DATA)	Blue/Yellow	n/a

ACC-HU-KEN2 Wire Description	Polarity	Wire Color on Adapter	Kenwood Radio
E-Brake	(-)	LtGreen	LtGreen
Reverse Light*	(+)	Purple/White	Purple/White
Steering Wheel Controls	(DATA)	Blue/Yellow	n/a

* Reverse light wire: Only connect to radio or module damage will occur.

MODULE DIAGNOSTICS



LED 1 Module/Firmware status	LED 2 (RR2) Bluetooth activity	LED STATUS	DIAGNOSTIC
or		RED or GREEN flashing	LED flashes 1 or more times, either red or green, when a steering wheel button is pressed : normal operation.
		1 RED flash	Module has no firmware. Flash module using Weblink Desktop and log in. Do <u>NOT</u> use DEMO MODE.
		2 RED flashes	Problem detected. Consult troubleshooting table.
		1 GREEN flash	After radio boots up : Normal operation.
		3 GREEN flashes	Bluetooth is activated. Turns off after one minute: Normal operation.
		OFF	Normal operation (inactive).

VIDEO HELP		Installation, product information, vehicle specific videos.
VERIFY FLASH		Last flash information, steering control configuration, vehicle information.
WEBLINK		Software to program module.

TROUBLESHOOTING TABLE

PROBLEM	SOLUTION
Gauges do not work, radio shows OBD2 Error 1 or Error 2.	<p>Ensure OBDII connector is securely attached to the OBDII connector of the vehicle.</p> <p>If you hardwired connections at the OBDII, check connections at the OBDII connector. Make sure the RED/BROWN wire is on PIN 6 and the YELLOW/BROWN wire is connected to PIN 14 of the OBDII connector. Do not use T-Taps. Soldering or military splicing methods are recommended.</p> <p>If anything else is connected to the OBD2 or CAN wires of vehicle (programmer, throttle controller, insurance tracker, etc.) try unplugging it to see if gauges work. If gauges work without it installed, call tech support for options.</p> <p>Reset the RR.</p>
The light on the Maestro is blinking RED TWICE and the radio IS turning on.	<p>Ensure the 4-pin data cable is connected between the radio and the RR, and that it is plugged into the black port on the Maestro RR. The red and blue ports on the RR should be empty.</p> <p>Make sure the correct radio model and serial number were entered during the flash. Verify the radio's serial number entered during the flash matches what is listed on the radio screen. This can be found in the settings of the radio, listed as Device Id, Device Number, or Serial Number.</p>
The light on the Maestro is blinking RED TWICE but the radio is NOT turning on.	<p>If installing a modular radio and it is not turning on, ensure the screen is secured and any trim pieces on the radio have been installed fully. Not installing these fully will prevent radio from powering up and show a 2x red error as well.</p> <p>Test red and yellow wires for DC voltage at radio using a multimeter. Contact support if no voltage on red or yellow.</p>
The steering wheel controls are not working, the Maestro RR does not blink when they are pressed.	<p>Ensure the 20 or 28-pin connector is plugged to the vehicle and to the T01 T-harness, as shown in step 3 (this is where the RR gets the steering wheel signal from the vehicle).</p>
(Prius only) After the car is turned off, the radio stays on. The car stays in accessory mode and will not turn off.	<p>Locate the white 12-pin connector of the T01 harness, it is connected to the vehicle harness.</p> <p>Then, cut and isolate the red wire located at pin 11. The radio will shut off when the vehicle is turned off.</p>

MAESTRO RR RESET PROCEDURE:

Turn the key to the OFF position, then disconnect all connectors from the module.

Press and hold the module's programming button and connect all the connectors back to the module. Wait, the module's LED will flash RED rapidly (this may take up to 10 seconds).

Release the programming button. Wait, the LED will turn solid GREEN for 2 seconds to show the reset was successful.

TECHNICAL ASSISTANCE

Phone: 1-866-427-2999

Email: maestro.support@idatalink.com

IMPORTANT: To ensure proper operation, the aftermarket radio needs to have the latest firmware from the manufacturer. Please visit the radio manufacturer's website and look for any updates pertaining to your radio.

RETAINS STEERING WHEEL CONTROLS, FACTORY AMPLIFIER, AND MORE!



PRODUCTS REQUIRED

iDatalink Maestro RR or RR2 Radio Replacement Interface
iDatalink Maestro HRR-T01 Installation Harness

PROGRAMMED FIRMWARE

ADS-RR(SR)-TOY01-DS

ADDITIONAL RESOURCES

[Maestro RR2 Programmable Outputs Guide](#)

OPTIONAL ACCESSORIES



Click here for:
[Radar Installation Guides](#)

HEAD UNIT ADAPTER:
ACC-HU-PI01, SON1, KEN1, KEN2, ALP1

WELCOME

Congratulations on the purchase of your iDatalink Maestro RR Radio replacement solution. You are now a few simple steps away from enjoying your new car radio with enhanced features.

Before starting your installation, please ensure that your iDatalink Maestro module is programmed with the correct firmware for your vehicle and that you carefully review the install guide.

Please note that Maestro RR will only retain functionalities that were originally available in the vehicle.

TABLE OF CONTENTS

Installation Instructions	3
Wiring Diagram	4
Radio Wire Reference Chart	5
Module Diagnostics	6
Troubleshooting Table	7

NEED HELP?

 1 866 427-2999

 maestro.support@idatalink.com

INSTALLATION INSTRUCTIONS P1/1

STEP 1

Remove the factory radio

If using head unit adapter (sold separately), connect HRR-T01 harness to adapter and skip to step 2.

- Unbox the aftermarket radio and locate its main harness.
- Cut and remove the black 20 pin connector from the HRR-T01 T-harness and connect the wires, shown in the wiring diagram, from aftermarket radio main harness to the HRR-T01 T-harness and match the wire functions.

Note: only connect purple/white wire to radio reverse input or module damage will occur.

STEP 2

- Identify if your vehicle has a 20 or 28 pin secondary connector.
- Assemble T01 T-harness as shown on wiring diagram.
- Connect the factory harness to the HRR-T01 harness.

STEP 3

- Connect HRR-T01 3-pin black connector to black connector of OBDII extension harness.
- Plug the OBDII connector into the OBDII of the vehicle.

STEP 4

- Plug the harnesses into the aftermarket radio.
- Plug the Data cable to the data port of the aftermarket radio.
- Insert the Audio cable into the iDatalink 3.5 mm audio jack of the aftermarket radio (if there is no iDatalink audio input, connect to AUX).

Note: On Pioneer radio, ensure that there is nothing plugged into the W/R port.

STEP 5

- Connect all the harnesses to the Maestro RR module then test your installation.

WIRING DIAGRAM *without an Amplifier*

STEP 1

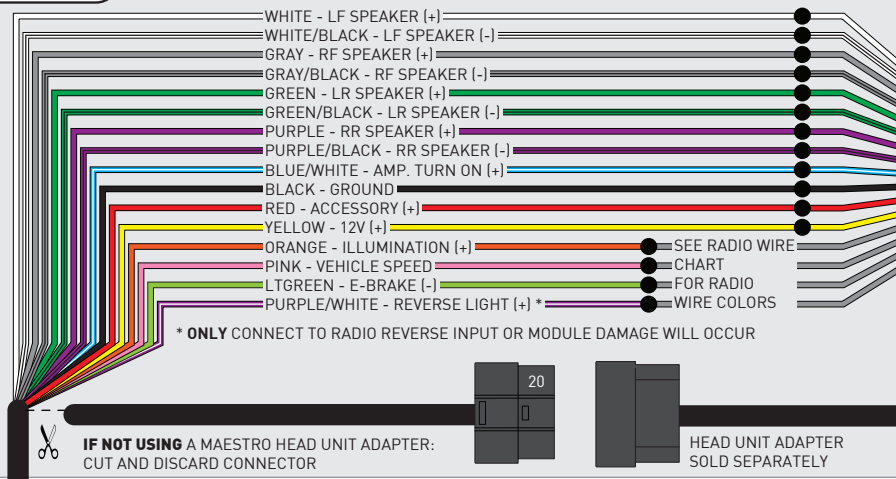

STEP 4

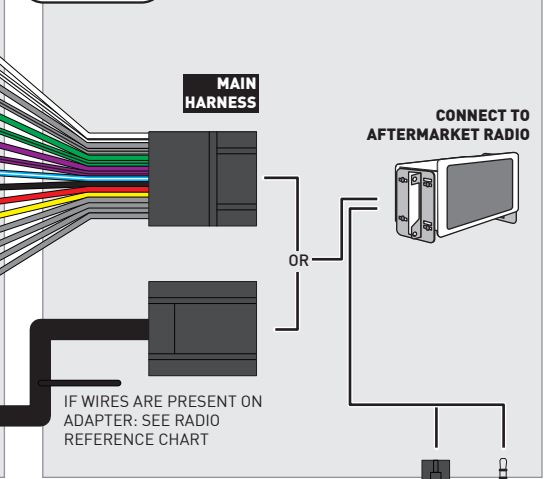

STEP 2

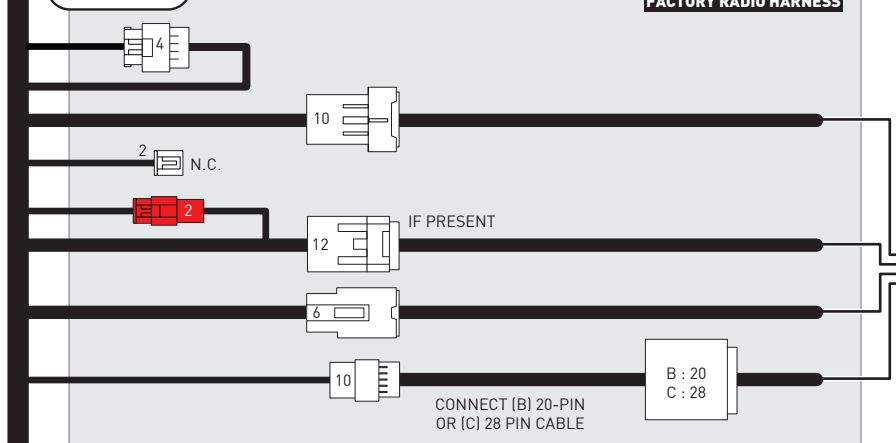

STEP 3

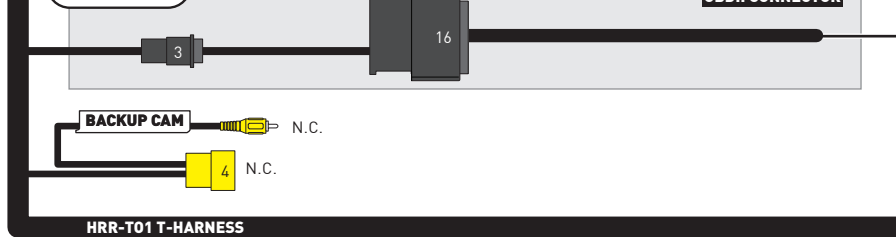

STEP 5

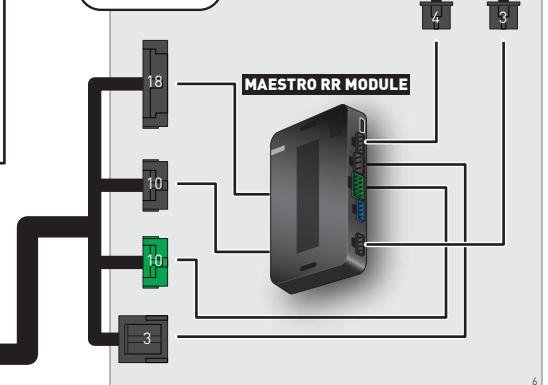

NOT REQUIRED

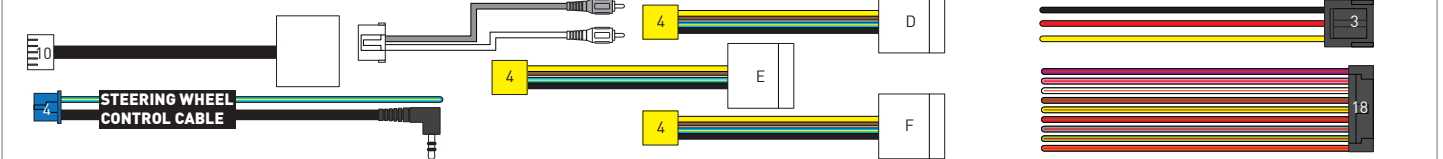

RADIO WIRE REFERENCE CHART

T01 T-harness Wire Description	Polarity	Wire Color on Maestro T-Harness	Wire Color on Alpine cable	Wire Color on Kenwood/JVC cable	Wire Color on Pioneer cable	Wire Color on Sony cable
Illumination	(+)	Orange	N/A	Orange/White	Orange/White	Orange
Reverse Light*	(+)	Purple/White	Orange/White	Purple/White	Purple/White	Purple/White
E-Brake	(-)	Lt Green	Yellow/Blue	Lt Green	Lt Green	Lt Green
VSS (vehicle speed sensor)	(DATA)	Pink	Green/White	Pink	Pink	N/A

Head unit adapter wiring (optional accessory, sold separately)

ACC-HU-ALP1 Wire Description	Polarity	Wire Color on Adapter	Alpine Radio
VSS (vehicle speed sensor)	(DATA)	Green/White	Green/White

ACC-HU-KEN1 Wire Description	Polarity	Wire Color on Adapter	Kenwood Radio
CAM	(+)	Green/Red	Refer to camera/radio manual
CAM	(-)	Green/White	Refer to camera/radio manual
Steering Wheel Controls	(DATA)	Blue/Yellow	n/a

ACC-HU-KEN2 Wire Description	Polarity	Wire Color on Adapter	Kenwood Radio
E-Brake	(-)	LtGreen	LtGreen
Reverse Light*	(+)	Purple/White	Purple/White
Steering Wheel Controls	(DATA)	Blue/Yellow	n/a

* Reverse light wire: Only connect to radio or module damage will occur.

MODULE DIAGNOSTICS



LED 1 Module/Firmware status	LED 2 (RR2) Bluetooth activity	LED STATUS	DIAGNOSTIC
or		RED or GREEN flashing	LED flashes 1 or more times, either red or green, when a steering wheel button is pressed : normal operation.
		1 RED flash	Module has no firmware. Flash module using Weblink Desktop and log in. Do <u>NOT</u> use DEMO MODE.
		2 RED flashes	Problem detected. Consult troubleshooting table.
		1 GREEN flash	After radio boots up : Normal operation.
		3 GREEN flashes	Bluetooth is activated. Turns off after one minute: Normal operation.
		OFF	Normal operation (inactive).

VIDEO HELP		Installation, product information, vehicle specific videos.
VERIFY FLASH		Last flash information, steering control configuration, vehicle information.
WEBLINK		Software to program module.

TROUBLESHOOTING TABLE

PROBLEM	SOLUTION
Gauges do not work, radio shows OBD2 Error 1 or Error 2.	<p>Ensure OBDII connector is securely attached to the OBDII connector of the vehicle.</p> <p>If you hardwired connections at the OBDII, check connections at the OBDII connector. Make sure the RED/BROWN wire is on PIN 6 and the YELLOW/BROWN wire is connected to PIN 14 of the OBDII connector. Do not use T-Taps. Soldering or military splicing methods are recommended.</p> <p>If anything else is connected to the OBD2 or CAN wires of vehicle (programmer, throttle controller, insurance tracker, etc.) try unplugging it to see if gauges work. If gauges work without it installed, call tech support for options.</p> <p>Reset the RR.</p>
The light on the Maestro is blinking RED TWICE and the radio IS turning on.	<p>Ensure the 4-pin data cable is connected between the radio and the RR, and that it is plugged into the black port on the Maestro RR. The red and blue ports on the RR should be empty.</p> <p>Make sure the correct radio model and serial number were entered during the flash. Verify the radio's serial number entered during the flash matches what is listed on the radio screen. This can be found in the settings of the radio, listed as Device Id, Device Number, or Serial Number.</p>
The light on the Maestro is blinking RED TWICE but the radio is NOT turning on.	<p>If installing a modular radio and it is not turning on, ensure the screen is secured and any trim pieces on the radio have been installed fully. Not installing these fully will prevent radio from powering up and show a 2x red error as well.</p> <p>Test red and yellow wires for DC voltage at radio using a multimeter. Contact support if no voltage on red or yellow.</p>
The steering wheel controls are not working, the Maestro RR does not blink when they are pressed.	<p>Ensure the 20 or 28-pin connector is plugged to the vehicle and to the T01 T-harness, as shown in step 3 (this is where the RR gets the steering wheel signal from the vehicle).</p>
(Prius only) After the car is turned off, the radio stays on. The car stays in accessory mode and will not turn off.	<p>Locate the white 12-pin connector of the T01 harness, it is connected to the vehicle harness.</p> <p>Then, cut and isolate the red wire located at pin 11. The radio will shut off when the vehicle is turned off.</p>

MAESTRO RR RESET PROCEDURE:

Turn the key to the OFF position, then disconnect all connectors from the module.

Press and hold the module's programming button and connect all the connectors back to the module. Wait, the module's LED will flash RED rapidly (this may take up to 10 seconds).

Release the programming button. Wait, the LED will turn solid GREEN for 2 seconds to show the reset was successful.

TECHNICAL ASSISTANCE

Phone: 1-866-427-2999

Email: maestro.support@idatalink.com

IMPORTANT: To ensure proper operation, the aftermarket radio needs to have the latest firmware from the manufacturer. Please visit the radio manufacturer's website and look for any updates pertaining to your radio.

RETAINS STEERING WHEEL CONTROLS, FACTORY AMPLIFIER, AND MORE!



PRODUCTS REQUIRED

iDatalink Maestro RR or RR2 Radio Replacement Interface
iDatalink Maestro HRR-T01 Installation Harness

PROGRAMMED FIRMWARE

ADS-RR(SR)-TOY01-DS

ADDITIONAL RESOURCES

[Maestro RR2 Programmable Outputs Guide](#)

OPTIONAL ACCESSORIES

K40
ELECTRONICS
ESCORT

Click here for:
[Radar Installation Guides](#)

HEAD UNIT ADAPTER:
ACC-HU-PI01, SON1, KEN1, KEN2, ALP1

WELCOME

Congratulations on the purchase of your iDatalink Maestro RR Radio replacement solution. You are now a few simple steps away from enjoying your new car radio with enhanced features.

Before starting your installation, please ensure that your iDatalink Maestro module is programmed with the correct firmware for your vehicle and that you carefully review the install guide.

Please note that Maestro RR will only retain functionalities that were originally available in the vehicle.

TABLE OF CONTENTS

Installation Instructions	3
Wiring Diagram	4
Radio Wire Reference Chart	5
Module Diagnostics	6
Troubleshooting Table	7

NEED HELP?

 1 866 427-2999

 maestro.support@idatalink.com

INSTALLATION INSTRUCTIONS P1/1

STEP 1

Remove the factory radio

If using head unit adapter (sold separately), connect HRR-T01 harness to adapter and skip to step 2.

- Unbox the aftermarket radio and locate its main harness.
- Cut and remove the black 20 pin connector from the HRR-T01 T-harness and connect the wires, shown in the wiring diagram, from aftermarket radio main harness to the HRR-T01 T-harness and match the wire functions.

Note: only connect purple/white wire to radio reverse input or module damage will occur.

STEP 2

- If the vehicle is equipped with an OEM backup camera, connect the HRR-T01 harness to appropriate HRR adapter cable (D, E or F) then connect to the backup camera harness.

STEP 3

- Identify if your vehicle has a 20 or 28 pin secondary connector.
- Assemble T01 T-harness as shown on wiring diagram.
- Connect the factory harness to the HRR-T01 harness.

STEP 4

- Connect HRR-T01 3-pin black connector to black connector of OBDII extension harness.
- Plug the OBDII connector into the OBDII of the vehicle.

STEP 5

- Plug the harnesses into the aftermarket radio.
- Connect the backup camera RCA cable into the aftermarket radio (if equipped).
- Plug the Data cable to the data port of the aftermarket radio.
- Insert the Audio cable into the iDatalink 3.5 mm audio jack of the aftermarket radio (if there is no iDatalink audio input, connect to AUX).

Note: On Pioneer radio, ensure that there is nothing plugged into the W/R port.

STEP 6

- Connect all the harnesses to the Maestro RR module then test your installation.

WIRING DIAGRAM *without an Amplifier*

STEP 1

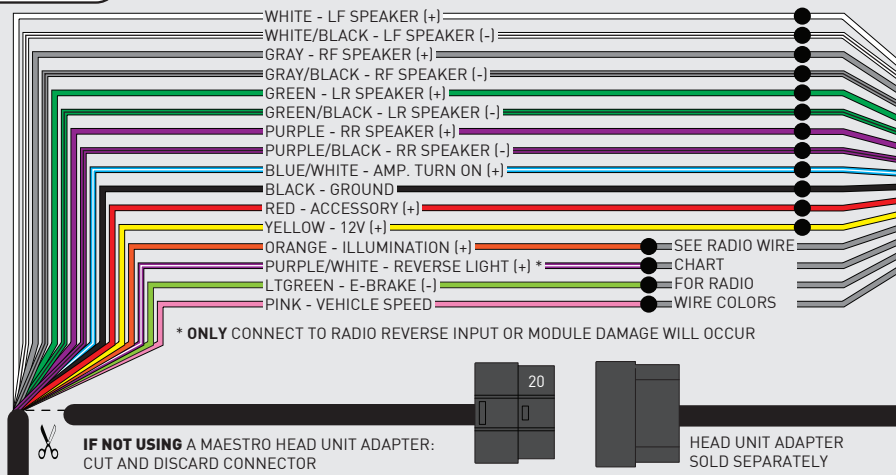

STEP 5

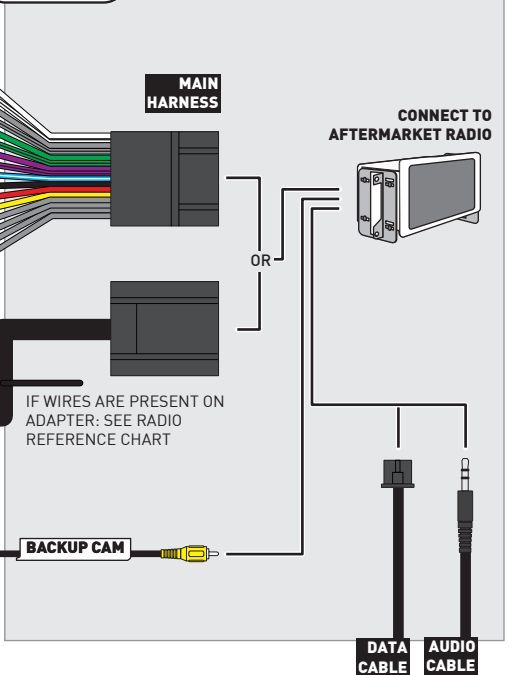

STEP 2

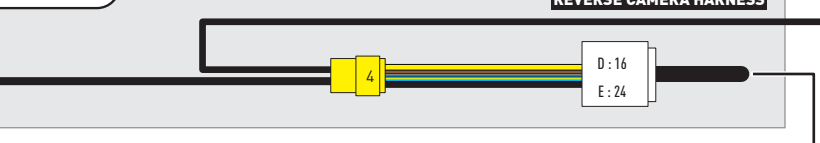

STEP 3

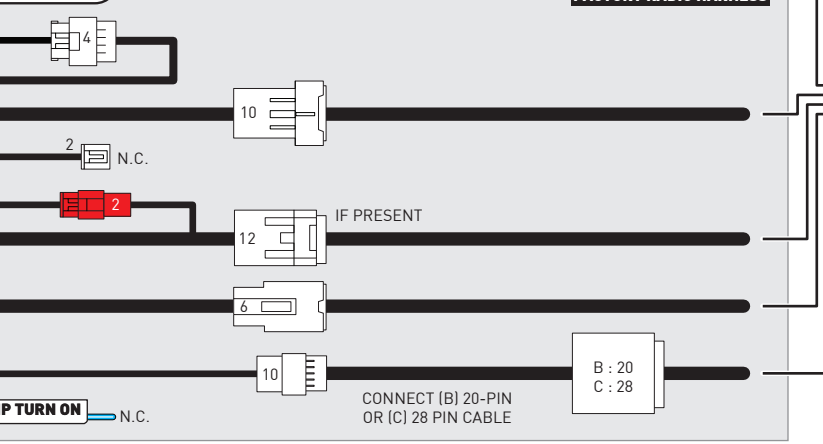

STEP 4



STEP 6

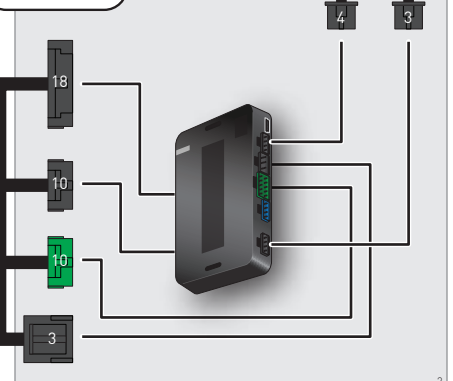

NOT REQUIRED

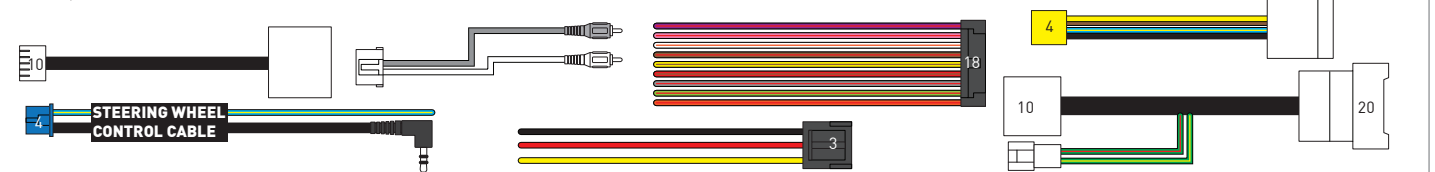

RADIO WIRE REFERENCE CHART

T01 T-harness Wire Description	Polarity	Wire Color on Maestro T-Harness	Wire Color on Alpine cable	Wire Color on Kenwood/ JVC cable	Wire Color on Pioneer cable	Wire Color on Sony cable
Illumination	(+)	Orange	N/A	Orange/White	Orange/White	Orange
Reverse Light*	(+)	Purple/White	Orange/White	Purple/White	Purple/White	Purple/White
E-Brake	(-)	Lt Green	Yellow/Blue	Lt Green	Lt Green	Lt Green
VSS (vehicle speed sensor)	(DATA)	Pink	Green/White	Pink	Pink	N/A

Head unit adapter wiring (optional accessory, sold separately)

ACC-HU-ALP1 Wire Description	Polarity	Wire Color on Adapter	Alpine Radio
VSS (vehicle speed sensor)	(DATA)	Green/White	Green/White

ACC-HU-KEN1 Wire Description	Polarity	Wire Color on Adapter	Kenwood Radio
CAM	(+)	Green/Red	Refer to camera/radio manual
CAM	(-)	Green/White	Refer to camera/radio manual
Steering Wheel Controls	(DATA)	Blue/Yellow	n/a

ACC-HU-KEN2 Wire Description	Polarity	Wire Color on Adapter	Kenwood Radio
E-Brake	(-)	LtGreen	LtGreen
Reverse Light*	(+)	Purple/White	Purple/White
Steering Wheel Controls	(DATA)	Blue/Yellow	n/a

* Reverse light wire: Only connect to radio or module damage will occur.

MODULE DIAGNOSTICS



LED 1 Module/Firmware status	LED 2 (RR2) Bluetooth activity	LED STATUS	DIAGNOSTIC
or		RED or GREEN flashing	LED flashes 1 or more times, either red or green, when a steering wheel button is pressed : normal operation.
		1 RED flash	Module has no firmware. Flash module using Weblink Desktop and log in. Do <u>NOT</u> use DEMO MODE.
		2 RED flashes	Problem detected. Consult troubleshooting table.
		1 GREEN flash	After radio boots up : Normal operation.
		3 GREEN flashes	Bluetooth is activated. Turns off after one minute: Normal operation.
		OFF	Normal operation (inactive).

VIDEO HELP		Installation, product information, vehicle specific videos.
VERIFY FLASH		Last flash information, steering control configuration, vehicle information.
WEBLINK		Software to program module.

TROUBLESHOOTING TABLE

PROBLEM	SOLUTION
Gauges do not work, radio shows OBD2 Error 1 or Error 2.	<p>Ensure OBDII connector is securely attached to the OBDII connector of the vehicle.</p> <p>If you hardwired connections at the OBDII, check connections at the OBDII connector. Make sure the RED/BROWN wire is on PIN 6 and the YELLOW/BROWN wire is connected to PIN 14 of the OBDII connector. Do not use T-Taps. Soldering or military splicing methods are recommended.</p> <p>If anything else is connected to the OBD2 or CAN wires of vehicle (programmer, throttle controller, insurance tracker, etc.) try unplugging it to see if gauges work. If gauges work without it installed, call tech support for options.</p> <p>Reset the RR.</p>
The light on the Maestro is blinking RED TWICE and the radio IS turning on.	<p>Ensure the 4-pin data cable is connected between the radio and the RR, and that it is plugged into the black port on the Maestro RR. The red and blue ports on the RR should be empty.</p> <p>Make sure the correct radio model and serial number were entered during the flash. Verify the radio's serial number entered during the flash matches what is listed on the radio screen. This can be found in the settings of the radio, listed as Device Id, Device Number, or Serial Number.</p>
The light on the Maestro is blinking RED TWICE but the radio is NOT turning on.	<p>If installing a modular radio and it is not turning on, ensure the screen is secured and any trim pieces on the radio have been installed fully. Not installing these fully will prevent radio from powering up and show a 2x red error as well.</p> <p>Test red and yellow wires for DC voltage at radio using a multimeter. Contact support if no voltage on red or yellow.</p>
The steering wheel controls are not working, the Maestro RR does not blink when they are pressed.	<p>Ensure the 20 or 28-pin connector is plugged to the vehicle and to the T01 T-harness, as shown in step 3 (this is where the RR gets the steering wheel signal from the vehicle).</p>
(Prius only) After the car is turned off, the radio stays on. The car stays in accessory mode and will not turn off.	<p>Locate the white 12-pin connector of the T01 harness, it is connected to the vehicle harness.</p> <p>Then, cut and isolate the red wire located at pin 11. The radio will shut off when the vehicle is turned off.</p>

MAESTRO RR RESET PROCEDURE:

Turn the key to the OFF position, then disconnect all connectors from the module.

Press and hold the module's programming button and connect all the connectors back to the module. Wait, the module's LED will flash RED rapidly (this may take up to 10 seconds).

Release the programming button. Wait, the LED will turn solid GREEN for 2 seconds to show the reset was successful.

TECHNICAL ASSISTANCE

Phone: 1-866-427-2999

Email: maestro.support@idatalink.com

IMPORTANT: To ensure proper operation, the aftermarket radio needs to have the latest firmware from the manufacturer. Please visit the radio manufacturer's website and look for any updates pertaining to your radio.

RETAINS STEERING WHEEL CONTROLS, FACTORY AMPLIFIER, AND MORE!



PRODUCTS REQUIRED

iDataLink Maestro RR or RR2 Radio Replacement Interface
iDataLink Maestro HRR-T01 Installation Harness

PROGRAMMED FIRMWARE

ADS-RR(SR)-TOY01-DS

ADDITIONAL RESOURCES

[Maestro RR2 Programmable Outputs Guide](#)

OPTIONAL ACCESSORIES

K40[™]
ELECTRONICS
ESCORT

Click here for:
[Radar Installation Guides](#)

HEAD UNIT ADAPTER:
ACC-HU-PI01, SON1, KEN1, KEN2, ALP1

WELCOME

Congratulations on the purchase of your iDatalink Maestro RR Radio replacement solution. You are now a few simple steps away from enjoying your new car radio with enhanced features.

Before starting your installation, please ensure that your iDatalink Maestro module is programmed with the correct firmware for your vehicle and that you carefully review the install guide.

Please note that Maestro RR will only retain functionalities that were originally available in the vehicle.

TABLE OF CONTENTS

Installation Instructions	3
Wiring Diagram	4
Radio Wire Reference Chart	5
Module Diagnostics	6
Troubleshooting Table	7

NEED HELP?

 1 866 427-2999

 maestro.support@idatalink.com

INSTALLATION INSTRUCTIONS P1/1

STEP 1

Remove the factory radio

If using head unit adapter (sold separately), connect HRR-T01 harness to adapter and skip to step 2.

- Unbox the aftermarket radio and locate its main harness.
- Cut and remove the black 20 pin connector from the HRR-T01 T-harness and connect the wires, shown in the wiring diagram, from aftermarket radio main harness to the HRR-T01 T-harness and match the wire functions.

Note: only connect purple/white wire to radio reverse input or module damage will occur.

STEP 2

- Identify if your vehicle has a 20 or 28 pin secondary connector.
- Assemble T01 T-harness as shown on wiring diagram.
- Connect the factory harness to the HRR-T01 harness.

STEP 3

- Connect HRR-T01 3-pin black connector to black connector of OBDII extension harness.
- Plug the OBDII connector into the OBDII of the vehicle.

STEP 4

- Plug the harnesses into the aftermarket radio.
- Plug the Data cable to the data port of the aftermarket radio.
- Insert the Audio cable into the iDatalink 3.5 mm audio jack of the aftermarket radio (if there is no iDatalink audio input, connect to AUX).

Note: On Pioneer radio, ensure that there is nothing plugged into the W/R port.

STEP 5

- Connect all the harnesses to the Maestro RR module then test your installation.

WIRING DIAGRAM *without an Amplifier*

STEP 1

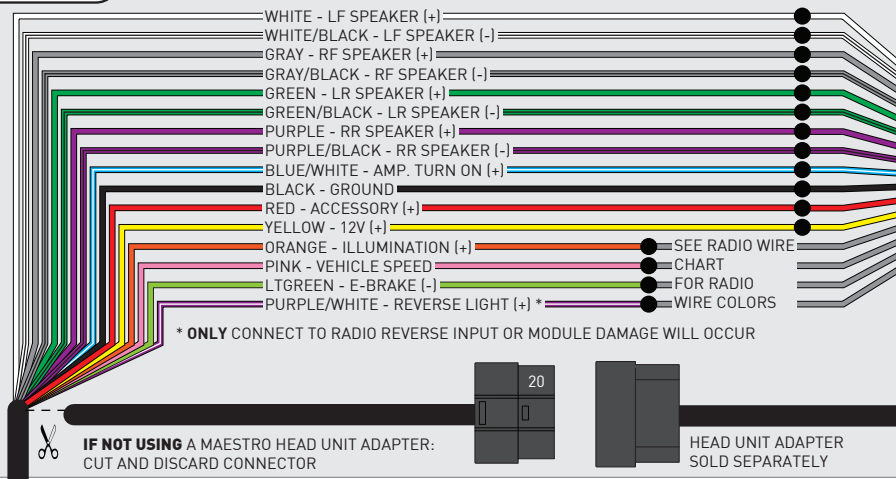

STEP 4

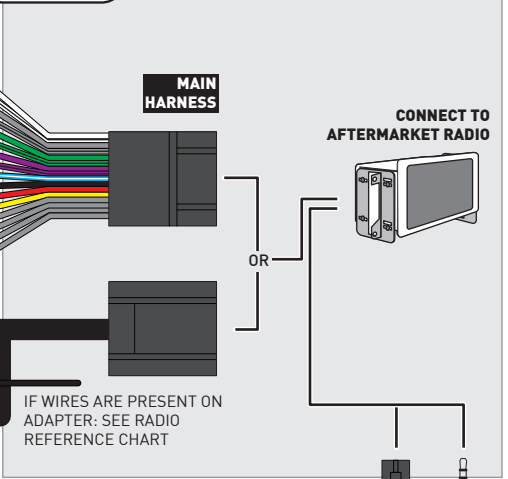

STEP 2

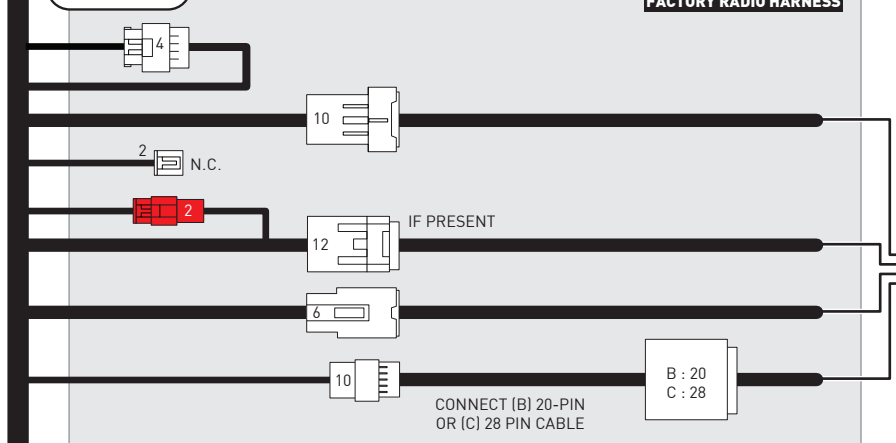

STEP 3

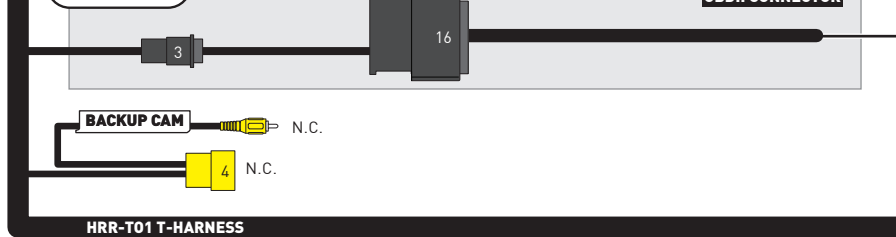

STEP 5

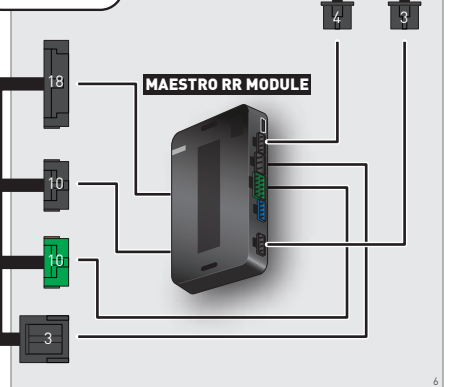

NOT REQUIRED

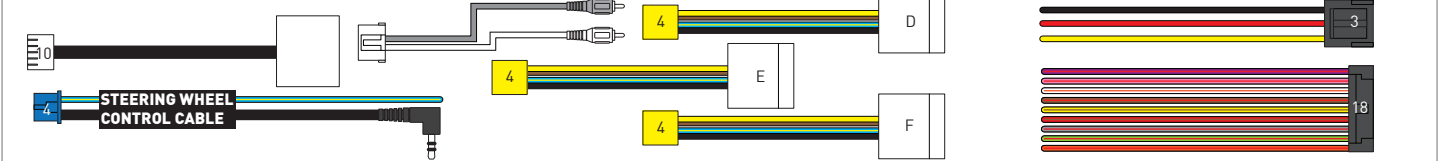

RADIO WIRE REFERENCE CHART

T01 T-harness Wire Description	Polarity	Wire Color on Maestro T-Harness	Wire Color on Alpine cable	Wire Color on Kenwood/ JVC cable	Wire Color on Pioneer cable	Wire Color on Sony cable
Illumination	(+)	Orange	N/A	Orange/White	Orange/White	Orange
Reverse Light*	(+)	Purple/White	Orange/White	Purple/White	Purple/White	Purple/White
E-Brake	(-)	Lt Green	Yellow/Blue	Lt Green	Lt Green	Lt Green
VSS (vehicle speed sensor)	(DATA)	Pink	Green/White	Pink	Pink	N/A

Head unit adapter wiring (optional accessory, sold separately)

ACC-HU-ALP1 Wire Description	Polarity	Wire Color on Adapter	Alpine Radio
VSS (vehicle speed sensor)	(DATA)	Green/White	Green/White

ACC-HU-KEN1 Wire Description	Polarity	Wire Color on Adapter	Kenwood Radio
CAM	(+)	Green/Red	Refer to camera/radio manual
CAM	(-)	Green/White	Refer to camera/radio manual
Steering Wheel Controls	(DATA)	Blue/Yellow	n/a

ACC-HU-KEN2 Wire Description	Polarity	Wire Color on Adapter	Kenwood Radio
E-Brake	(-)	LtGreen	LtGreen
Reverse Light*	(+)	Purple/White	Purple/White
Steering Wheel Controls	(DATA)	Blue/Yellow	n/a

* Reverse light wire: Only connect to radio or module damage will occur.

MODULE DIAGNOSTICS



LED 1 Module/Firmware status	LED 2 (RR2) Bluetooth activity	LED STATUS	DIAGNOSTIC
or		RED or GREEN flashing	LED flashes 1 or more times, either red or green, when a steering wheel button is pressed : normal operation.
		1 RED flash	Module has no firmware. Flash module using Weblink Desktop and log in. Do <u>NOT</u> use DEMO MODE.
		2 RED flashes	Problem detected. Consult troubleshooting table.
		1 GREEN flash	After radio boots up : Normal operation.
		3 GREEN flashes	Bluetooth is activated. Turns off after one minute: Normal operation.
		OFF	Normal operation (inactive).

VIDEO HELP		Installation, product information, vehicle specific videos.
VERIFY FLASH		Last flash information, steering control configuration, vehicle information.
WEBLINK		Software to program module.

TROUBLESHOOTING TABLE

PROBLEM	SOLUTION
Gauges do not work, radio shows OBD2 Error 1 or Error 2.	<p>Ensure OBDII connector is securely attached to the OBDII connector of the vehicle.</p> <p>If you hardwired connections at the OBDII, check connections at the OBDII connector. Make sure the RED/BROWN wire is on PIN 6 and the YELLOW/BROWN wire is connected to PIN 14 of the OBDII connector. Do not use T-Taps. Soldering or military splicing methods are recommended.</p> <p>If anything else is connected to the OBD2 or CAN wires of vehicle (programmer, throttle controller, insurance tracker, etc.) try unplugging it to see if gauges work. If gauges work without it installed, call tech support for options.</p> <p>Reset the RR.</p>
The light on the Maestro is blinking RED TWICE and the radio IS turning on.	<p>Ensure the 4-pin data cable is connected between the radio and the RR, and that it is plugged into the black port on the Maestro RR. The red and blue ports on the RR should be empty.</p> <p>Make sure the correct radio model and serial number were entered during the flash. Verify the radio's serial number entered during the flash matches what is listed on the radio screen. This can be found in the settings of the radio, listed as Device Id, Device Number, or Serial Number.</p>
The light on the Maestro is blinking RED TWICE but the radio is NOT turning on.	<p>If installing a modular radio and it is not turning on, ensure the screen is secured and any trim pieces on the radio have been installed fully. Not installing these fully will prevent radio from powering up and show a 2x red error as well.</p> <p>Test red and yellow wires for DC voltage at radio using a multimeter. Contact support if no voltage on red or yellow.</p>
The steering wheel controls are not working, the Maestro RR does not blink when they are pressed.	<p>Ensure the 20 or 28-pin connector is plugged to the vehicle and to the T01 T-harness, as shown in step 3 (this is where the RR gets the steering wheel signal from the vehicle).</p>
(Prius only) After the car is turned off, the radio stays on. The car stays in accessory mode and will not turn off.	<p>Locate the white 12-pin connector of the T01 harness, it is connected to the vehicle harness.</p> <p>Then, cut and isolate the red wire located at pin 11. The radio will shut off when the vehicle is turned off.</p>

MAESTRO RR RESET PROCEDURE:

Turn the key to the OFF position, then disconnect all connectors from the module.

Press and hold the module's programming button and connect all the connectors back to the module. Wait, the module's LED will flash RED rapidly (this may take up to 10 seconds).

Release the programming button. Wait, the LED will turn solid GREEN for 2 seconds to show the reset was successful.

TECHNICAL ASSISTANCE

Phone: 1-866-427-2999

Email: maestro.support@idatalink.com

IMPORTANT: To ensure proper operation, the aftermarket radio needs to have the latest firmware from the manufacturer. Please visit the radio manufacturer's website and look for any updates pertaining to your radio.

RETAINS STEERING WHEEL CONTROLS, FACTORY AMPLIFIER, AND MORE!



PRODUCTS REQUIRED

iDatalink Maestro RR or RR2 Radio Replacement Interface
iDatalink Maestro HRR-T01 Installation Harness

PROGRAMMED FIRMWARE

ADS-RR(SR)-TOY01-DS

ADDITIONAL RESOURCES

[Maestro RR2 Programmable Outputs Guide](#)

OPTIONAL ACCESSORIES

K40[™]
ELECTRONICS
ESCORT

Click here for:
[Radar Installation Guides](#)

HEAD UNIT ADAPTER:
ACC-HU-PI01, SON1, KEN1, KEN2, ALP1

WELCOME

Congratulations on the purchase of your iDatalink Maestro RR Radio replacement solution. You are now a few simple steps away from enjoying your new car radio with enhanced features.

Before starting your installation, please ensure that your iDatalink Maestro module is programmed with the correct firmware for your vehicle and that you carefully review the install guide.

Please note that Maestro RR will only retain functionalities that were originally available in the vehicle.

TABLE OF CONTENTS

Installation Instructions	3
Wiring Diagram	4
Radio Wire Reference Chart	5
Module Diagnostics	6
Troubleshooting Table	7

NEED HELP?

 1 866 427-2999

 maestro.support@idatalink.com

INSTALLATION INSTRUCTIONS P1/1

STEP 1

Remove the factory radio

If using head unit adapter (sold separately), connect HRR-T01 harness to adapter and skip to step 2.

- Unbox the aftermarket radio and locate its main harness.
- Cut and remove the black 20 pin connector from the HRR-T01 T-harness and connect the wires, shown in the wiring diagram, from aftermarket radio main harness to the HRR-T01 T-harness and match the wire functions.

Note: only connect purple/white wire to radio reverse input or module damage will occur.

STEP 2

- Identify if your vehicle has a 20 or 28 pin secondary connector.
- Assemble T01 T-harness as shown on wiring diagram.
- Connect the factory harness to the HRR-T01 harness.

STEP 3

- Connect HRR-T01 3-pin black connector to black connector of OBDII extension harness.
- Plug the OBDII connector into the OBDII of the vehicle.

STEP 4

- Plug the harnesses into the aftermarket radio.
- Plug the Data cable to the data port of the aftermarket radio.
- Insert the Audio cable into the iDatalink 3.5 mm audio jack of the aftermarket radio (if there is no iDatalink audio input, connect to AUX).

Note: On Pioneer radio, ensure that there is nothing plugged into the W/R port.

STEP 5

- Connect all the harnesses to the Maestro RR module then test your installation.

WIRING DIAGRAM *without an Amplifier*

STEP 1

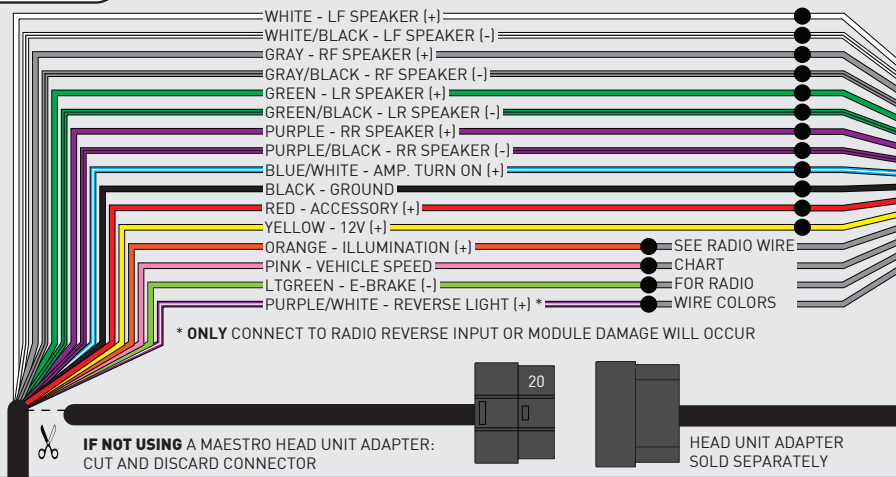

STEP 4

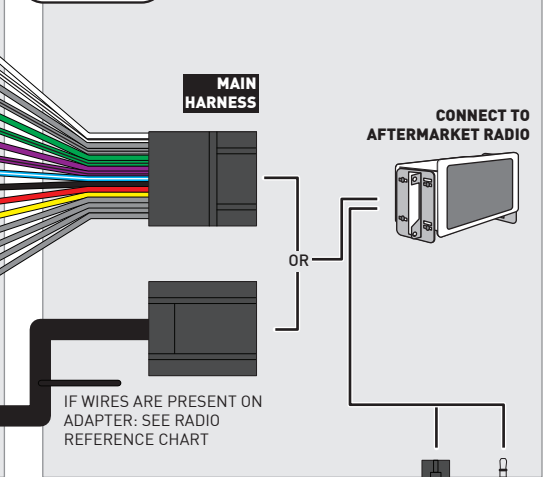

STEP 2

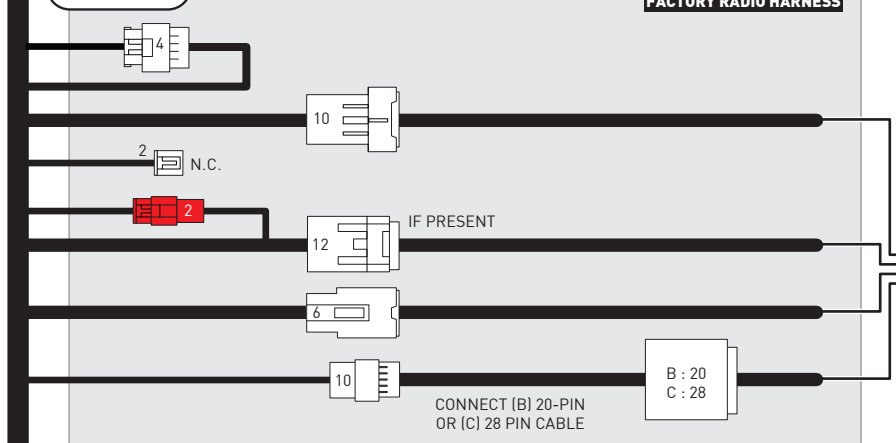

STEP 3

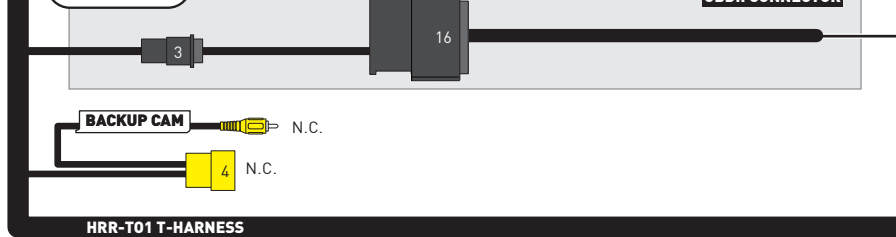

STEP 5

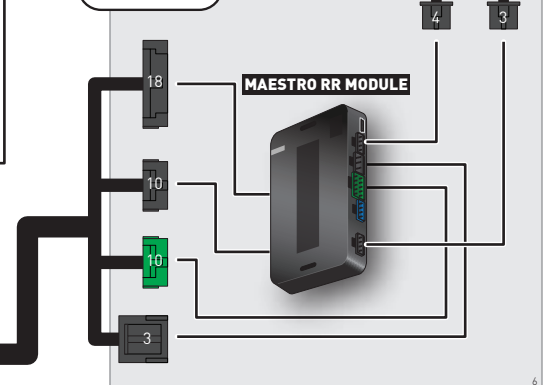

NOT REQUIRED

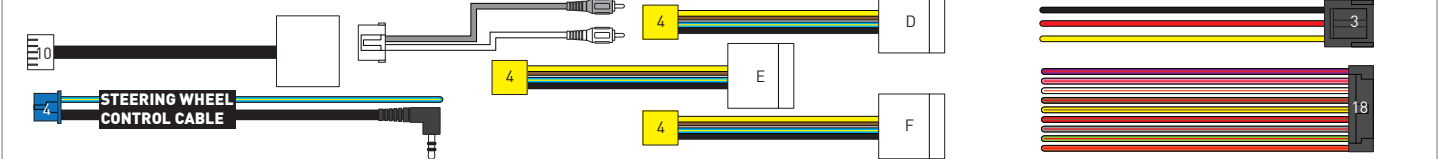

RADIO WIRE REFERENCE CHART

T01 T-harness Wire Description	Polarity	Wire Color on Maestro T-Harness	Wire Color on Alpine cable	Wire Color on Kenwood/JVC cable	Wire Color on Pioneer cable	Wire Color on Sony cable
Illumination	(+)	Orange	N/A	Orange/White	Orange/White	Orange
Reverse Light*	(+)	Purple/White	Orange/White	Purple/White	Purple/White	Purple/White
E-Brake	(-)	Lt Green	Yellow/Blue	Lt Green	Lt Green	Lt Green
VSS (vehicle speed sensor)	(DATA)	Pink	Green/White	Pink	Pink	N/A

Head unit adapter wiring (optional accessory, sold separately)

ACC-HU-ALP1 Wire Description	Polarity	Wire Color on Adapter	Alpine Radio
VSS (vehicle speed sensor)	(DATA)	Green/White	Green/White

ACC-HU-KEN1 Wire Description	Polarity	Wire Color on Adapter	Kenwood Radio
CAM	(+)	Green/Red	Refer to camera/radio manual
CAM	(-)	Green/White	Refer to camera/radio manual
Steering Wheel Controls	(DATA)	Blue/Yellow	n/a

ACC-HU-KEN2 Wire Description	Polarity	Wire Color on Adapter	Kenwood Radio
E-Brake	(-)	LtGreen	LtGreen
Reverse Light*	(+)	Purple/White	Purple/White
Steering Wheel Controls	(DATA)	Blue/Yellow	n/a

* Reverse light wire: Only connect to radio or module damage will occur.

MODULE DIAGNOSTICS



LED 1 Module/Firmware status	LED 2 (RR2) Bluetooth activity	LED STATUS	DIAGNOSTIC
or		RED or GREEN flashing	LED flashes 1 or more times, either red or green, when a steering wheel button is pressed : normal operation.
		1 RED flash	Module has no firmware. Flash module using Weblink Desktop and log in. Do <u>NOT</u> use DEMO MODE.
		2 RED flashes	Problem detected. Consult troubleshooting table.
		1 GREEN flash	After radio boots up : Normal operation.
		3 GREEN flashes	Bluetooth is activated. Turns off after one minute: Normal operation.
		OFF	Normal operation (inactive).

VIDEO HELP		Installation, product information, vehicle specific videos.
VERIFY FLASH		Last flash information, steering control configuration, vehicle information.
WEBLINK		Software to program module.

TROUBLESHOOTING TABLE

PROBLEM	SOLUTION
Gauges do not work, radio shows OBD2 Error 1 or Error 2.	<p>Ensure OBDII connector is securely attached to the OBDII connector of the vehicle.</p> <p>If you hardwired connections at the OBDII, check connections at the OBDII connector. Make sure the RED/BROWN wire is on PIN 6 and the YELLOW/BROWN wire is connected to PIN 14 of the OBDII connector. Do not use T-Taps. Soldering or military splicing methods are recommended.</p> <p>If anything else is connected to the OBD2 or CAN wires of vehicle (programmer, throttle controller, insurance tracker, etc.) try unplugging it to see if gauges work. If gauges work without it installed, call tech support for options.</p> <p>Reset the RR.</p>
The light on the Maestro is blinking RED TWICE and the radio IS turning on.	<p>Ensure the 4-pin data cable is connected between the radio and the RR, and that it is plugged into the black port on the Maestro RR. The red and blue ports on the RR should be empty.</p> <p>Make sure the correct radio model and serial number were entered during the flash. Verify the radio's serial number entered during the flash matches what is listed on the radio screen. This can be found in the settings of the radio, listed as Device Id, Device Number, or Serial Number.</p>
The light on the Maestro is blinking RED TWICE but the radio is NOT turning on.	<p>If installing a modular radio and it is not turning on, ensure the screen is secured and any trim pieces on the radio have been installed fully. Not installing these fully will prevent radio from powering up and show a 2x red error as well.</p> <p>Test red and yellow wires for DC voltage at radio using a multimeter. Contact support if no voltage on red or yellow.</p>
The steering wheel controls are not working, the Maestro RR does not blink when they are pressed.	<p>Ensure the 20 or 28-pin connector is plugged to the vehicle and to the T01 T-harness, as shown in step 3 (this is where the RR gets the steering wheel signal from the vehicle).</p>
(Prius only) After the car is turned off, the radio stays on. The car stays in accessory mode and will not turn off.	<p>Locate the white 12-pin connector of the T01 harness, it is connected to the vehicle harness.</p> <p>Then, cut and isolate the red wire located at pin 11. The radio will shut off when the vehicle is turned off.</p>

MAESTRO RR RESET PROCEDURE:

Turn the key to the OFF position, then disconnect all connectors from the module.

Press and hold the module's programming button and connect all the connectors back to the module. Wait, the module's LED will flash RED rapidly (this may take up to 10 seconds).

Release the programming button. Wait, the LED will turn solid GREEN for 2 seconds to show the reset was successful.

TECHNICAL ASSISTANCE

Phone: 1-866-427-2999

Email: maestro.support@idatalink.com

IMPORTANT: To ensure proper operation, the aftermarket radio needs to have the latest firmware from the manufacturer. Please visit the radio manufacturer's website and look for any updates pertaining to your radio.