



HOW TO USE THIS INSTALL GUIDE

- 1** Open the Bookmarks menu and find your vehicle OR scroll down until you find the install guide for your vehicle.
- 2** Print only the pages for your vehicle using the advanced options in the Print menu.
- 3** Install your Maestro RR according to the guide for your vehicle.

WARNING

Pressing the printer icon or “quick printing” this document will print all of the guides in this compilation.

RETAINS STEERING WHEEL CONTROLS, VEHICLE SETTINGS, AND MORE!



PRODUCTS REQUIRED

iDataLink Maestro RR or RR2 Radio Replacement Interface
iDataLink Maestro HRR-MA2 Installation Harness

PROGRAMMED FIRMWARE

ADS-RR(SR)-MA1-DS

ADDITIONAL RESOURCES

[Maestro RR2 Programmable Outputs Guide](#)

OPTIONAL ACCESSORIES

K40[™]
ELECTRONICS
ESCORT

Click here for:
[Radar Installation Guides](#)

ANTENNA ADAPTER (MAY BE REQUIRED)

HEAD UNIT ADAPTER:
ACC-HU-PI01, SON1, KEN1, KEN2, ALP1

WELCOME

Congratulations on the purchase of your iDatalink Maestro RR Radio replacement solution. You are now a few simple steps away from enjoying your new car radio with enhanced features.

Before starting your installation, please ensure that your iDatalink Maestro module is programmed with the correct firmware for your vehicle and that you carefully review the install guide.

Please note that Maestro RR will only retain functionalities that were originally available in the vehicle.

NEED HELP?

 1 866 427-2999

 maestro.support@idatalink.com

 maestro.idatalink.com/support
www.12voldata.com/forum

TABLE OF CONTENTS

Installation Instructions	3
Wiring Diagram	4
Radio Wire Reference Chart	5
Module Diagnostics	6
Troubleshooting Table	7

INSTALLATION INSTRUCTIONS P1/1

STEP 1

- **Disconnect the negative battery terminal** (not doing so may blow the 7.5A audio fuse 2 under hood during the installation of the radio).
- Remove the factory radio

If using head unit adapter (sold separately), connect HRR-MA2 harness to adapter and skip to step 2.

- Unbox the aftermarket radio and locate its main harness.
- Cut and remove the black 20 pin connector from the HRR-MA2 T-harness and connect the wires, shown in the wiring diagram, from aftermarket radio main harness to the HRR-MA2 T-harness and match the wire functions.

Note: only connect purple/white wire to radio reverse input or module damage will occur.

STEP 2

If the vehicle DOES NOT have a factory amplifier:

- Plug in the extension harness to HRR-MA2 main harness 8-pin black connector.

If the vehicle DOES have a factory amplifier:

- Plug in the extension harness to 8-pin black connector of RCA cable.
- Connect the RCAs to the radio outputs: white/left front, gray/right front, green/left rear, purple/right rear.
- Route the extension harness to the radio tuner in the passenger kick panel.

STEP 3

- Connect both the 18-pin and 28-pin connectors of HRR-MA2 T-harness to the factory radio harness (at CMU, behind/below display).

STEP 4

- Connect the 24-pin adapter (red connector) to the factory radio tuner in the passenger kick panel.
- Connect the adapter's 8-pin black connector to the extension harness.
- Plug the blue POWER ANT terminal to amplified antenna adapter (if required).

STEP 5

- Plug the harnesses into the aftermarket radio.
- Connect the backup cam cable into the aftermarket radio (if equipped).
- Plug the antenna adapter (if required).
- Plug the Data cable to the data port of the aftermarket radio.

Note: On Pioneer radio, ensure that there is nothing plugged into the W/R port.

STEP 6

- Connect all the harnesses to the Maestro RR module.
- **Reconnect the negative battery terminal then test your installation.**

WIRING DIAGRAM

STEP 1

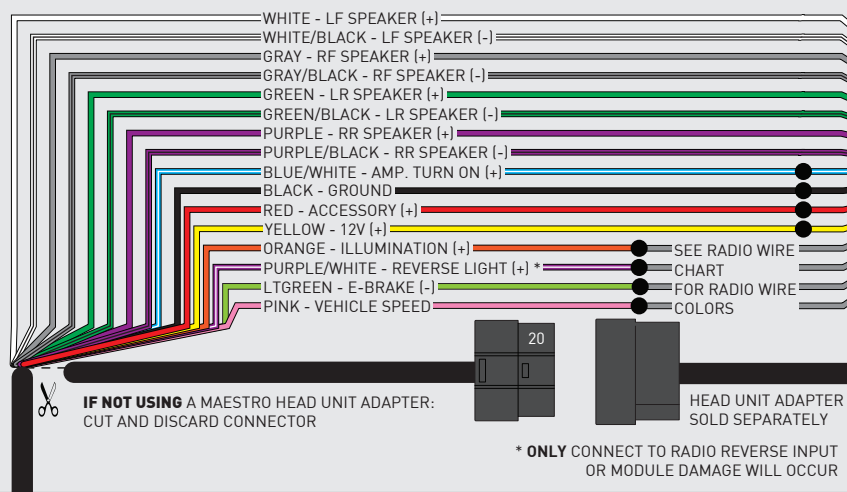

STEP 5

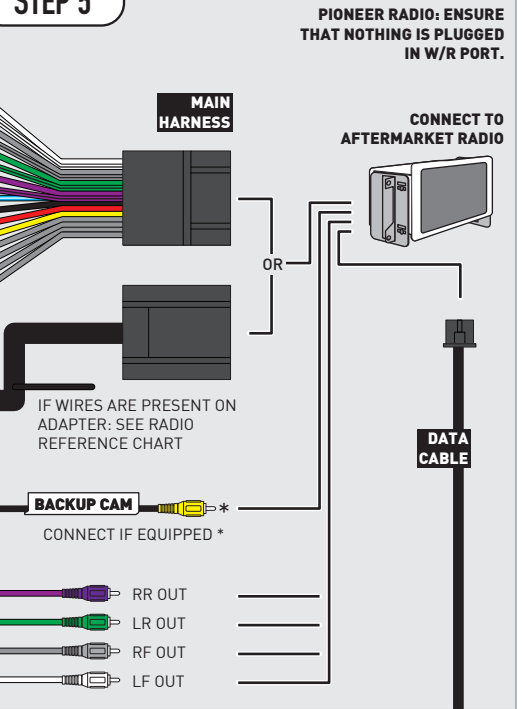

STEP 2

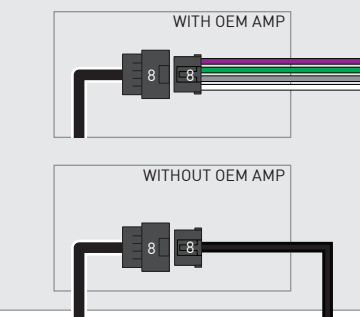

STEP 3

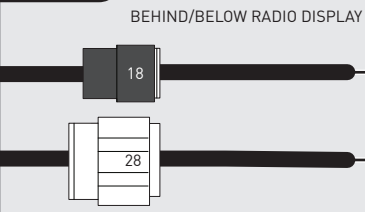

STEP 4

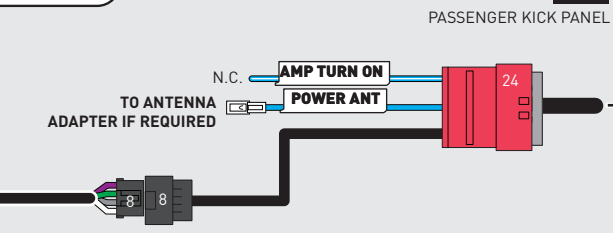

STEP 6

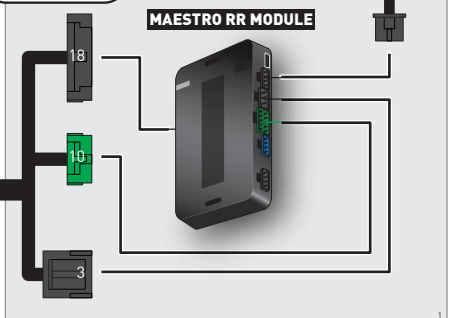

NOT REQUIRED

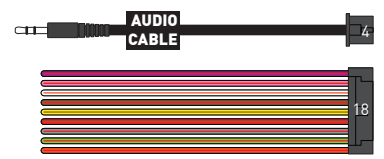
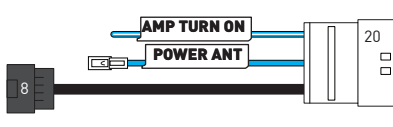
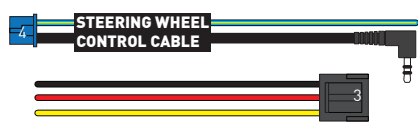

RADIO WIRE REFERENCE CHART

MA2 T-harness Wire Description	Polarity	Wire Color on Maestro T-Harness	Wire Color on Alpine cable	Wire Color on Kenwood cable	Wire Color on Pioneer cable	Wire Color on Sony cable
Illumination	(+)	Orange	N/A	Orange/White	Orange/White	Orange
Reverse Light*	(+)	Purple/White	Orange/White	Purple/White	Purple/White	Purple/White
E-Brake	(-)	Lt Green	Yellow/Blue	Lt Green	Lt Green	Lt Green
VSS (vehicle speed sensor)	(DATA)	Pink	Green/White	Pink	Pink	N/A

Head unit adapter wiring (optional accessory, sold separately)

ACC-HU-ALP1 Wire Description	Polarity	Wire Color on Adapter	Alpine Radio
VSS (vehicle speed sensor)	(DATA)	Green/White	Green/White

ACC-HU-KEN1 Wire Description	Polarity	Wire Color on Adapter	Kenwood Radio
CAM	(+)	Green/Red	Refer to camera/radio manual
CAM	(-)	Green/White	Refer to camera/radio manual
Steering Wheel Controls	(DATA)	Blue/Yellow	n/a

ACC-HU-KEN2 Wire Description	Polarity	Wire Color on Adapter	Kenwood Radio
E-Brake	(-)	LtGreen	LtGreen
Reverse Light*	(+)	Purple/White	Purple/White
Steering Wheel Controls	(DATA)	Blue/Yellow	n/a

* Reverse light wire: Only connect to radio or module damage will occur.

MODULE DIAGNOSTICS



LED 1 Module/Firmware status	LED 2 (RR2) Bluetooth activity	LED STATUS	DIAGNOSTIC
● or ●		RED or GREEN flashing	LED flashes 1 or more times, either red or green, when a steering wheel button is pressed : normal operation.
●		1 RED flash	Module has no firmware. Flash module using Weblink Desktop and log in. Do <u>NOT</u> use DEMO MODE.
●		2 RED flashes	Problem detected. Consult troubleshooting table.
●		1 GREEN flash	After radio boots up : Normal operation.
	●	3 GREEN flashes	Bluetooth is activated. Turns off after one minute: Normal operation.
●	●	OFF	Normal operation (inactive).

VIDEO HELP		Installation, product information, vehicle specific videos.
VERIFY FLASH		Last flash information, steering control configuration, vehicle information.
WEBLINK		Software to program module.

TROUBLESHOOTING TABLE

PROBLEM	SOLUTION
Gauges do not work, radio shows OBD2 Error 1 or Error 2.	If anything is connected to the OBD2 or CAN wires of vehicle (programmer, throttle controller, insurance tracker, etc.) try unplugging it to see if gauges work. If gauges work without it installed, call tech support for options. Reset the RR.
CX-5 and Mazda3 No audio after installing new radio. Factory radio no longer has sound.	Check 7.5 amp "AUDIO 2" fuse located under the hood.
The light on the Maestro is flashing RED ONCE .	There is no firmware on the module. Flash the RR module using Weblink Desktop and log in. Do NOT use DEMO MODE.
The light on the Maestro is blinking RED TWICE and the radio IS turning on.	Ensure the 4-pin data cable is connected between the radio and the RR, and that it is plugged into the black port on the Maestro RR. The red and blue ports on the RR should be empty. Make sure the correct radio model and serial number were entered during the flash. Verify the radio's serial number entered during the flash matches what is listed on the radio screen. This can be found in the settings of the radio, listed as Device Id, Device Number, or Serial Number.
The light on the Maestro is blinking RED TWICE but the radio is NOT turning on.	If installing a modular radio and it is not turning on, ensure the screen is secured and any trim pieces on the radio have been installed fully. Not installing these fully will prevent radio from powering up and show a 2x red error as well. Test red and yellow wires for DC voltage at radio using a multimeter. Contact support if no voltage on red or yellow.

MAESTRO RR RESET PROCEDURE:

Turn the key to the OFF position, then disconnect all connectors from the module.

Press and hold the module's programming button and connect all the connectors back to the module. Wait, the module's LED will flash RED rapidly (this may take up to 10 seconds).

Release the programming button. Wait, the LED will turn solid GREEN for 2 seconds to show the reset was successful.

TECHNICAL ASSISTANCE

Phone: 1-866-427-2999

Email: maestro.support@idatalink.com

Web: maestro.idatalink.com/support add www.12voldata.com/forum/

IMPORTANT: To ensure proper operation, the aftermarket radio needs to have the latest firmware from the manufacturer. Please visit the radio manufacturer's website and look for any updates pertaining to your radio.

2018

MAZDA 3

TOUCHSCREEN WITH AMPLIFIER

RETAINS STEERING WHEEL CONTROLS, VEHICLE SETTINGS, AND MORE!



PRODUCTS REQUIRED

iDatalink Maestro RR or RR2 Radio Replacement Interface
iDatalink Maestro HRR-MA2 Installation Harness

PROGRAMMED FIRMWARE

ADS-RR(SR)-MA1-DS

ADDITIONAL RESOURCES

[Maestro RR2 Programmable Outputs Guide](#)

OPTIONAL ACCESSORIES



Click here for:
[Radar Installation Guides](#)

ANTENNA ADAPTER (MAY BE REQUIRED)

HEAD UNIT ADAPTER:
ACC-HU-PI01, SON1, KEN1, KEN2, ALP1

WELCOME

Congratulations on the purchase of your iDatalink Maestro RR Radio replacement solution. You are now a few simple steps away from enjoying your new car radio with enhanced features.

Before starting your installation, please ensure that your iDatalink Maestro module is programmed with the correct firmware for your vehicle and that you carefully review the install guide.

Please note that Maestro RR will only retain functionalities that were originally available in the vehicle.

NEED HELP?

 1 866 427-2999

 maestro.support@idatalink.com

 maestro.idatalink.com/support
www.12voltdata.com/forum

TABLE OF CONTENTS

Installation Instructions	3
Wiring Diagram	4
Radio Wire Reference Chart	5
Module Diagnostics	6
Troubleshooting Table	7

INSTALLATION INSTRUCTIONS P1/1

STEP 1

- **Disconnect the negative battery terminal** (not doing so may blow the 7.5A audio fuse 2 under hood during the installation of the radio).
- Remove the factory radio

If using head unit adapter (sold separately), connect HRR-MA2 harness to adapter and skip to step 2.

- Unbox the aftermarket radio and locate its main harness.
- Cut and remove the black 20 pin connector from the HRR-MA2 T-harness and connect the wires, shown in the wiring diagram, from aftermarket radio main harness to the HRR-MA2 T-harness and match the wire functions.

Note: only connect purple/white wire to radio reverse input or module damage will occur.

STEP 2

- Plug in the extension harness to 8-pin black connector of RCA cable.
- Connect the RCAs to the radio outputs: white/left front, gray/right front, green/left rear, purple/right rear.
- Route the extension harness to the radio tuner in the passenger kick panel.

STEP 3

- Connect both the 18-pin and 28-pin connectors of HRR-MA2 T-harness to the factory radio harness (at CMU, behind/below display).

STEP 4

- Connect the 24-pin adapter (red connector) to the factory radio tuner in the passenger kick panel.
- Connect the adapter's 8-pin black connector to the extension harness.
- Connect the adapter's AMP TURN ON blue/white wire to tuner's white wire at pin 6 of 32-pin white connector.
- Plug the blue POWER ANT terminal to amplified antenna adapter (if required).

STEP 5

- Plug the harnesses into the aftermarket radio.
- Connect the backup cam cable into the aftermarket radio (if equipped).
- Plug the antenna adapter (if required).
- Plug the Data cable to the data port of the aftermarket radio.

Note: On Pioneer radio, ensure that there is nothing plugged into the W/R port.

STEP 6

- Connect all the harnesses to the Maestro RR module.
- **Reconnect the negative battery terminal then test your installation.**

WIRING DIAGRAM

STEP 1

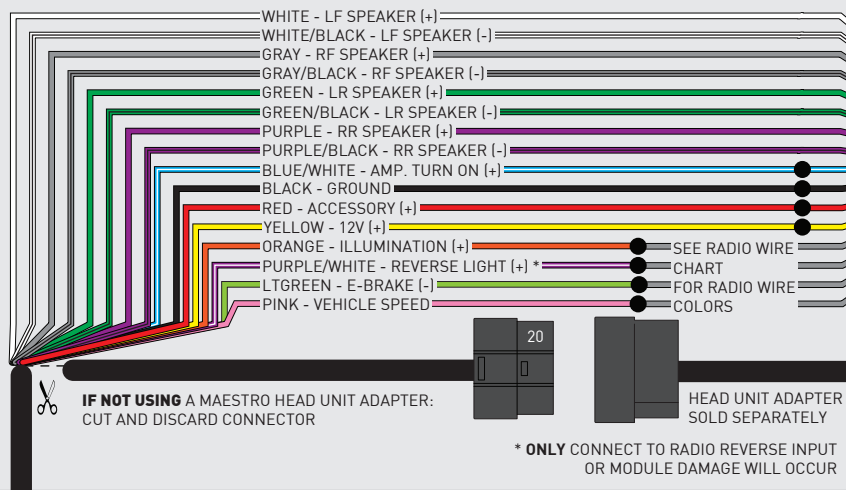

STEP 5

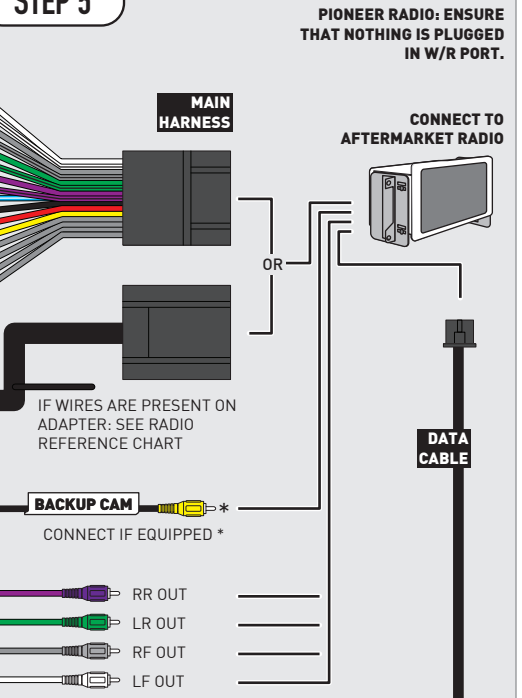

STEP 2

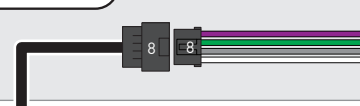

STEP 3

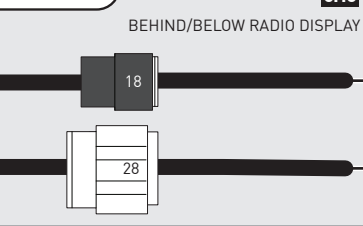

STEP 4

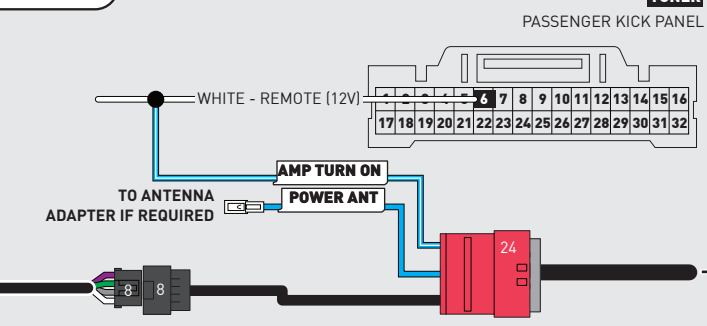

STEP 6

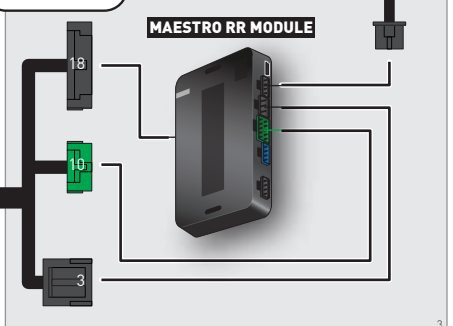

NOT REQUIRED

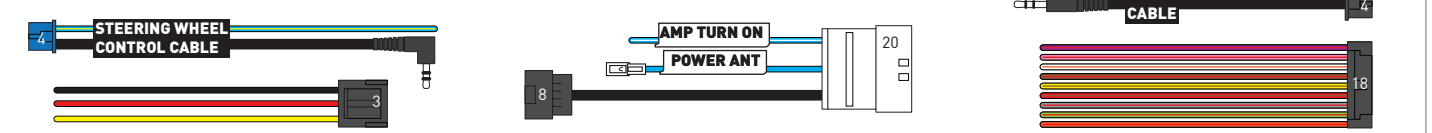

RADIO WIRE REFERENCE CHART

MA2 T-harness Wire Description	Polarity	Wire Color on Maestro T-Harness	Wire Color on Alpine cable	Wire Color on Kenwood cable	Wire Color on Pioneer cable	Wire Color on Sony cable
Illumination	(+)	Orange	N/A	Orange/White	Orange/White	Orange
Reverse Light*	(+)	Purple/White	Orange/White	Purple/White	Purple/White	Purple/White
E-Brake	(-)	Lt Green	Yellow/Blue	Lt Green	Lt Green	Lt Green
VSS (vehicle speed sensor)	(DATA)	Pink	Green/White	Pink	Pink	N/A

Head unit adapter wiring (optional accessory, sold separately)

ACC-HU-ALP1 Wire Description	Polarity	Wire Color on Adapter	Alpine Radio
VSS (vehicle speed sensor)	(DATA)	Green/White	Green/White

ACC-HU-KEN1 Wire Description	Polarity	Wire Color on Adapter	Kenwood Radio
CAM	(+)	Green/Red	Refer to camera/radio manual
CAM	(-)	Green/White	Refer to camera/radio manual
Steering Wheel Controls	(DATA)	Blue/Yellow	n/a

ACC-HU-KEN2 Wire Description	Polarity	Wire Color on Adapter	Kenwood Radio
E-Brake	(-)	LtGreen	LtGreen
Reverse Light*	(+)	Purple/White	Purple/White
Steering Wheel Controls	(DATA)	Blue/Yellow	n/a

* Reverse light wire: Only connect to radio or module damage will occur.

MODULE DIAGNOSTICS



LED 1 Module/Firmware status	LED 2 (RR2) Bluetooth activity	LED STATUS	DIAGNOSTIC
● or ●		RED or GREEN flashing	LED flashes 1 or more times, either red or green, when a steering wheel button is pressed : normal operation.
●		1 RED flash	Module has no firmware. Flash module using Weblink Desktop and log in. Do <u>NOT</u> use DEMO MODE.
●		2 RED flashes	Problem detected. Consult troubleshooting table.
●		1 GREEN flash	After radio boots up : Normal operation.
	●	3 GREEN flashes	Bluetooth is activated. Turns off after one minute: Normal operation.
●	●	OFF	Normal operation (inactive).

VIDEO HELP		Installation, product information, vehicle specific videos.
VERIFY FLASH		Last flash information, steering control configuration, vehicle information.
WEBLINK		Software to program module.

TROUBLESHOOTING TABLE

PROBLEM	SOLUTION
Gauges do not work, radio shows OBD2 Error 1 or Error 2.	If anything is connected to the OBD2 or CAN wires of vehicle (programmer, throttle controller, insurance tracker, etc.) try unplugging it to see if gauges work. If gauges work without it installed, call tech support for options. Reset the RR.
CX-5 and Mazda3 No audio after installing new radio. Factory radio no longer has sound.	Check 7.5 amp "AUDIO 2" fuse located under the hood.
The light on the Maestro is flashing RED ONCE .	There is no firmware on the module. Flash the RR module using Weblink Desktop and log in. Do NOT use DEMO MODE.
The light on the Maestro is blinking RED TWICE and the radio IS turning on.	Ensure the 4-pin data cable is connected between the radio and the RR, and that it is plugged into the black port on the Maestro RR. The red and blue ports on the RR should be empty. Make sure the correct radio model and serial number were entered during the flash. Verify the radio's serial number entered during the flash matches what is listed on the radio screen. This can be found in the settings of the radio, listed as Device Id, Device Number, or Serial Number.
The light on the Maestro is blinking RED TWICE but the radio is NOT turning on.	If installing a modular radio and it is not turning on, ensure the screen is secured and any trim pieces on the radio have been installed fully. Not installing these fully will prevent radio from powering up and show a 2x red error as well. Test red and yellow wires for DC voltage at radio using a multimeter. Contact support if no voltage on red or yellow.

MAESTRO RR RESET PROCEDURE:

Turn the key to the OFF position, then disconnect all connectors from the module.

Press and hold the module's programming button and connect all the connectors back to the module. Wait, the module's LED will flash RED rapidly (this may take up to 10 seconds).

Release the programming button. Wait, the LED will turn solid GREEN for 2 seconds to show the reset was successful.

TECHNICAL ASSISTANCE

Phone: 1-866-427-2999

Email: maestro.support@idatalink.com

Web: maestro.idatalink.com/support add www.12voldata.com/forum/

IMPORTANT: To ensure proper operation, the aftermarket radio needs to have the latest firmware from the manufacturer. Please visit the radio manufacturer's website and look for any updates pertaining to your radio.

2018

MAZDA 3

TOUCHSCREEN WITHOUT AMPLIFIER

RETAINS STEERING WHEEL CONTROLS, VEHICLE SETTINGS, AND MORE!



PRODUCTS REQUIRED

iDataLink Maestro RR or RR2 Radio Replacement Interface
iDataLink Maestro HRR-MA2 Installation Harness

PROGRAMMED FIRMWARE

ADS-RR(SR)-MA1-DS

ADDITIONAL RESOURCES

[Maestro RR2 Programmable Outputs Guide](#)

OPTIONAL ACCESSORIES

K40
ELECTRONICS
ESCORT

Click here for:
[Radar Installation Guides](#)

ANTENNA ADAPTER (MAY BE REQUIRED)

HEAD UNIT ADAPTER:
ACC-HU-PI01, SON1, KEN1, KEN2, ALP1

WELCOME

Congratulations on the purchase of your iDatalink Maestro RR Radio replacement solution. You are now a few simple steps away from enjoying your new car radio with enhanced features.

Before starting your installation, please ensure that your iDatalink Maestro module is programmed with the correct firmware for your vehicle and that you carefully review the install guide.

Please note that Maestro RR will only retain functionalities that were originally available in the vehicle.

NEED HELP?

 1 866 427-2999

 maestro.support@idatalink.com

 maestro.idatalink.com/support
www.12voldata.com/forum

TABLE OF CONTENTS

Installation Instructions	3
Wiring Diagram	4
Radio Wire Reference Chart	5
Module Diagnostics	6
Troubleshooting Table	7

INSTALLATION INSTRUCTIONS P1/1

STEP 1

- **Disconnect the negative battery terminal** (not doing so may blow the 7.5A audio fuse 2 under hood during the installation of the radio).
- Remove the factory radio
If using head unit adapter (sold separately), connect HRR-MA2 harness to adapter and skip to step 2.
- Unbox the aftermarket radio and locate its main harness.
- Cut and remove the black 20 pin connector from the HRR-MA2 T-harness and connect the wires, shown in the wiring diagram, from aftermarket radio main harness to the HRR-MA2 T-harness and match the wire functions.
Note: only connect purple/white wire to radio reverse input or module damage will occur.

STEP 2

- Plug in the extension harness to HRR-MA2 main harness 8-pin black connector.
- Route the extension harness to the radio tuner in the passenger kick panel.

STEP 3

- Connect both the 18-pin and 28-pin connectors of HRR-MA2 T-harness to the factory radio harness (at CMU, behind/below display).

STEP 4

- Connect the 24-pin adapter (red connector) to the factory radio tuner in the passenger kick panel.
- Connect the adapter's 8-pin black connector to the extension harness.
- Plug the blue POWER ANT terminal to amplified antenna adapter (if required).

STEP 5

- Plug the harnesses into the aftermarket radio.
- Connect the backup cam cable into the aftermarket radio (if equipped).
- Plug the antenna adapter (if required).
- Plug the Data cable to the data port of the aftermarket radio.

Note: On Pioneer radio, ensure that there is nothing plugged into the W/R port.

STEP 6

- Connect all the harnesses to the Maestro RR module.
- **Reconnect the negative battery terminal then test your installation.**

WIRING DIAGRAM

STEP 1

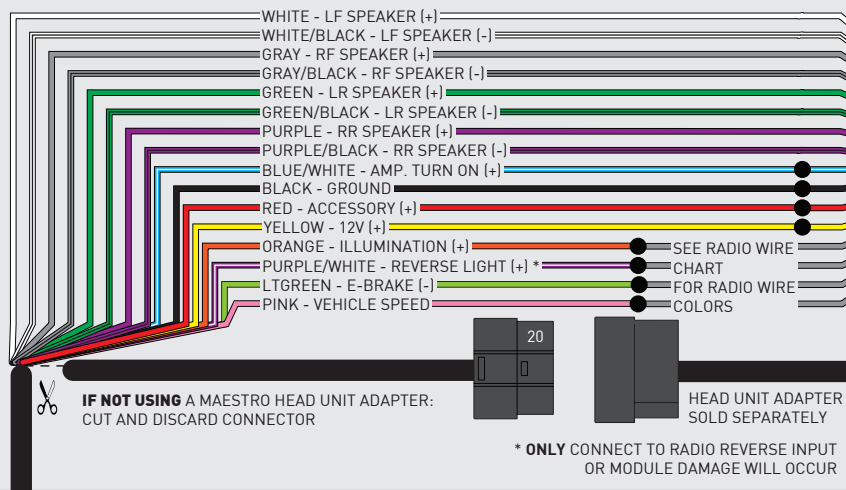

STEP 5

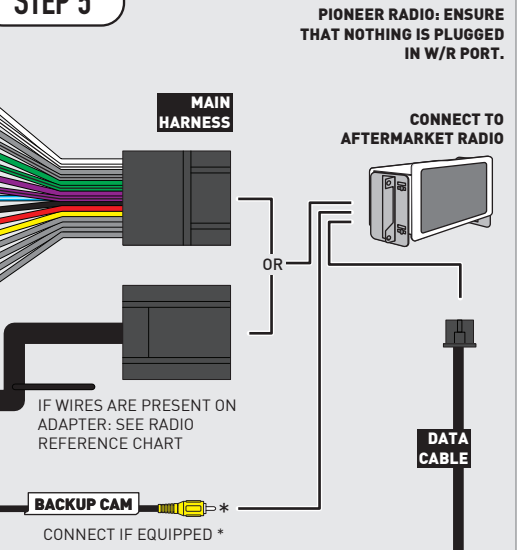

STEP 2

STEP 3

STEP 4

STEP 6

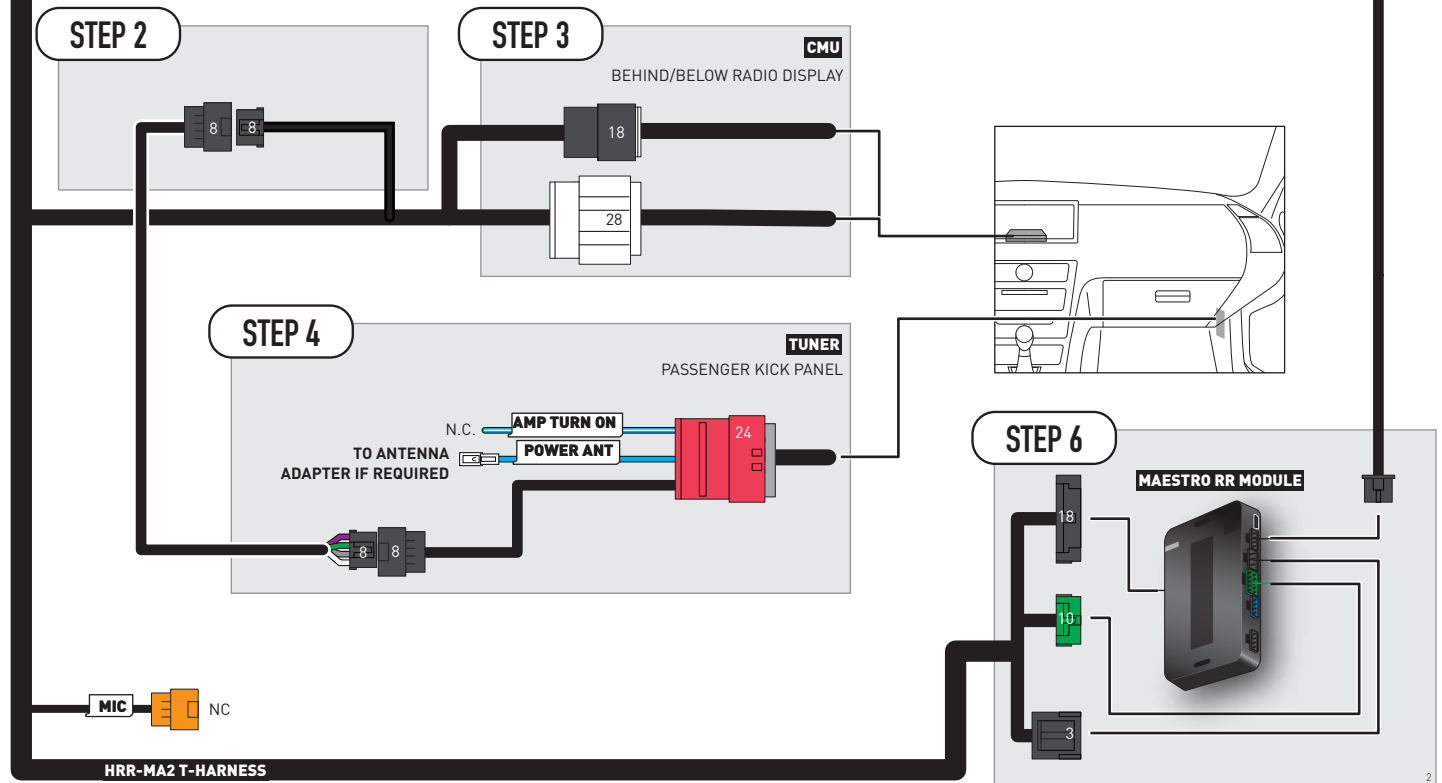

NOT REQUIRED

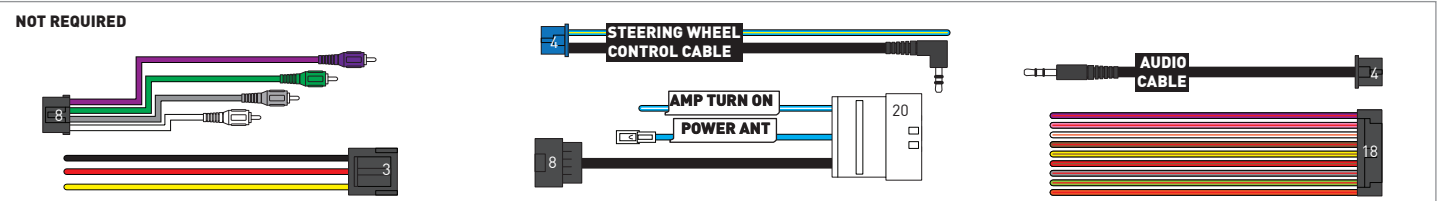

RADIO WIRE REFERENCE CHART

MA2 T-harness Wire Description	Polarity	Wire Color on Maestro T-Harness	Wire Color on Alpine cable	Wire Color on Kenwood cable	Wire Color on Pioneer cable	Wire Color on Sony cable
Illumination	(+)	Orange	N/A	Orange/White	Orange/White	Orange
Reverse Light*	(+)	Purple/White	Orange/White	Purple/White	Purple/White	Purple/White
E-Brake	(-)	Lt Green	Yellow/Blue	Lt Green	Lt Green	Lt Green
VSS (vehicle speed sensor)	(DATA)	Pink	Green/White	Pink	Pink	N/A

Head unit adapter wiring (optional accessory, sold separately)

ACC-HU-ALP1 Wire Description	Polarity	Wire Color on Adapter	Alpine Radio
VSS (vehicle speed sensor)	(DATA)	Green/White	Green/White

ACC-HU-KEN1 Wire Description	Polarity	Wire Color on Adapter	Kenwood Radio
CAM	(+)	Green/Red	Refer to camera/radio manual
CAM	(-)	Green/White	Refer to camera/radio manual
Steering Wheel Controls	(DATA)	Blue/Yellow	n/a

ACC-HU-KEN2 Wire Description	Polarity	Wire Color on Adapter	Kenwood Radio
E-Brake	(-)	LtGreen	LtGreen
Reverse Light*	(+)	Purple/White	Purple/White
Steering Wheel Controls	(DATA)	Blue/Yellow	n/a

* Reverse light wire: Only connect to radio or module damage will occur.

MODULE DIAGNOSTICS



LED 1 Module/Firmware status	LED 2 (RR2) Bluetooth activity	LED STATUS	DIAGNOSTIC
● or ●		RED or GREEN flashing	LED flashes 1 or more times, either red or green, when a steering wheel button is pressed : normal operation.
●		1 RED flash	Module has no firmware. Flash module using Weblink Desktop and log in. Do <u>NOT</u> use DEMO MODE.
●		2 RED flashes	Problem detected. Consult troubleshooting table.
●		1 GREEN flash	After radio boots up : Normal operation.
	●	3 GREEN flashes	Bluetooth is activated. Turns off after one minute: Normal operation.
●	●	OFF	Normal operation (inactive).

VIDEO HELP		Installation, product information, vehicle specific videos.
VERIFY FLASH		Last flash information, steering control configuration, vehicle information.
WEBLINK		Software to program module.

TROUBLESHOOTING TABLE

PROBLEM	SOLUTION
Gauges do not work, radio shows OBD2 Error 1 or Error 2.	If anything is connected to the OBD2 or CAN wires of vehicle (programmer, throttle controller, insurance tracker, etc.) try unplugging it to see if gauges work. If gauges work without it installed, call tech support for options. Reset the RR.
CX-5 and Mazda3 No audio after installing new radio. Factory radio no longer has sound.	Check 7.5 amp "AUDIO 2" fuse located under the hood.
The light on the Maestro is flashing RED ONCE .	There is no firmware on the module. Flash the RR module using Weblink Desktop and log in. Do NOT use DEMO MODE.
The light on the Maestro is blinking RED TWICE and the radio IS turning on.	Ensure the 4-pin data cable is connected between the radio and the RR, and that it is plugged into the black port on the Maestro RR. The red and blue ports on the RR should be empty. Make sure the correct radio model and serial number were entered during the flash. Verify the radio's serial number entered during the flash matches what is listed on the radio screen. This can be found in the settings of the radio, listed as Device Id, Device Number, or Serial Number.
The light on the Maestro is blinking RED TWICE but the radio is NOT turning on.	If installing a modular radio and it is not turning on, ensure the screen is secured and any trim pieces on the radio have been installed fully. Not installing these fully will prevent radio from powering up and show a 2x red error as well. Test red and yellow wires for DC voltage at radio using a multimeter. Contact support if no voltage on red or yellow.

MAESTRO RR RESET PROCEDURE:

Turn the key to the OFF position, then disconnect all connectors from the module.

Press and hold the module's programming button and connect all the connectors back to the module. Wait, the module's LED will flash RED rapidly (this may take up to 10 seconds).

Release the programming button. Wait, the LED will turn solid GREEN for 2 seconds to show the reset was successful.

TECHNICAL ASSISTANCE

Phone: 1-866-427-2999

Email: maestro.support@idatalink.com

Web: maestro.idatalink.com/support add www.12voldata.com/forum/

IMPORTANT: To ensure proper operation, the aftermarket radio needs to have the latest firmware from the manufacturer. Please visit the radio manufacturer's website and look for any updates pertaining to your radio.

RETAINS STEERING WHEEL CONTROLS, VEHICLE SETTINGS, AND MORE!



PRODUCTS REQUIRED

iDataLink Maestro RR or RR2 Radio Replacement Interface
iDataLink Maestro HRR-MA2 Installation Harness

PROGRAMMED FIRMWARE

ADS-RR(SR)-MA1-DS

ADDITIONAL RESOURCES

[Maestro RR2 Programmable Outputs Guide](#)

OPTIONAL ACCESSORIES

K40[™]
ELECTRONICS
ESCORT

Click here for:
[Radar Installation Guides](#)

ANTENNA ADAPTER (MAY BE REQUIRED)

HEAD UNIT ADAPTER:
ACC-HU-PI01, SON1, KEN1, KEN2, ALP1

WELCOME

Congratulations on the purchase of your iDatalink Maestro RR Radio replacement solution. You are now a few simple steps away from enjoying your new car radio with enhanced features.

Before starting your installation, please ensure that your iDatalink Maestro module is programmed with the correct firmware for your vehicle and that you carefully review the install guide.

Please note that Maestro RR will only retain functionalities that were originally available in the vehicle.

NEED HELP?

 1 866 427-2999

 maestro.support@idatalink.com

 maestro.idatalink.com/support
www.12voldata.com/forum

TABLE OF CONTENTS

Installation Instructions	3
Wiring Diagram	4
Radio Wire Reference Chart	5
Module Diagnostics	6
Troubleshooting Table	7

INSTALLATION INSTRUCTIONS P1/1

STEP 1

- **Disconnect the negative battery terminal** (not doing so may blow the 7.5A audio fuse 2 under hood during the installation of the radio).
- Remove the factory radio

If using head unit adapter (sold separately), connect HRR-MA2 harness to adapter and skip to step 2.

- Unbox the aftermarket radio and locate its main harness.
- Cut and remove the black 20 pin connector from the HRR-MA2 T-harness and connect the wires, shown in the wiring diagram, from aftermarket radio main harness to the HRR-MA2 T-harness and match the wire functions.

Note: only connect purple/white wire to radio reverse input or module damage will occur.

STEP 2

If the vehicle DOES NOT have a factory amplifier:

- Plug in the extension harness to HRR-MA2 main harness 8-pin black connector.

If the vehicle DOES have a factory amplifier:

- Plug in the extension harness to 8-pin black connector of RCA cable.
- Connect the RCAs to the radio outputs: white/left front, gray/right front, green/left rear, purple/right rear.
- Route the extension harness to the radio tuner in the passenger kick panel.

STEP 3

- Connect both the 18-pin and 28-pin connectors of HRR-MA2 T-harness to the factory radio harness (at CMU, behind/below display).

STEP 4

- Connect the 24-pin adapter (red connector) to the factory radio tuner in the passenger kick panel.
- Connect the adapter's 8-pin black connector to the extension harness.
- Plug the blue POWER ANT terminal to amplified antenna adapter (if required).

STEP 5

- Plug the harnesses into the aftermarket radio.
- Connect the backup cam cable into the aftermarket radio (if equipped).
- Plug the antenna adapter (if required).
- Plug the Data cable to the data port of the aftermarket radio.

Note: On Pioneer radio, ensure that there is nothing plugged into the W/R port.

STEP 6

- Connect all the harnesses to the Maestro RR module.
- **Reconnect the negative battery terminal then test your installation.**

WIRING DIAGRAM

STEP 1

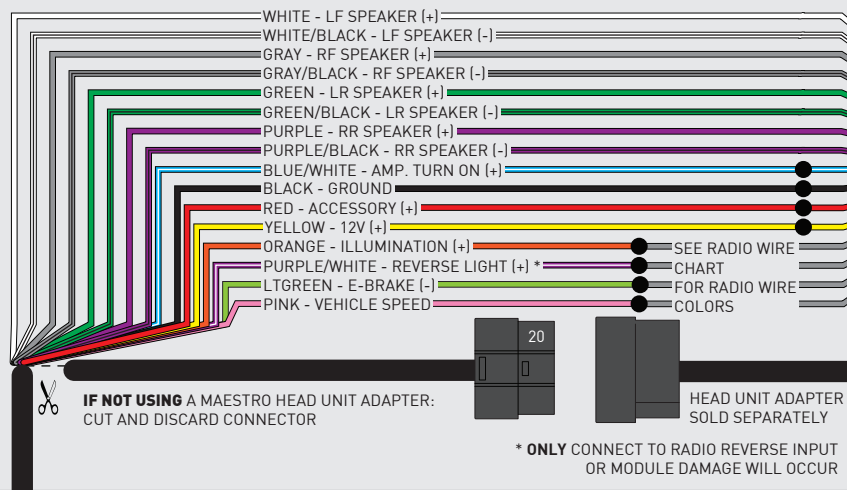

STEP 5

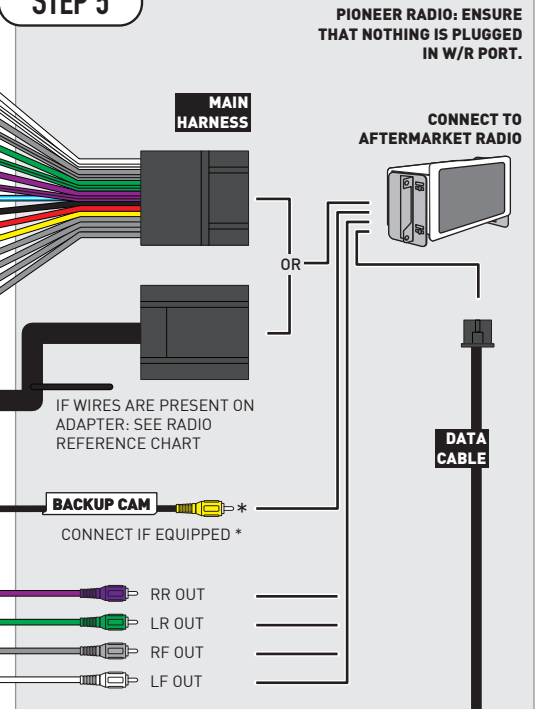

STEP 2

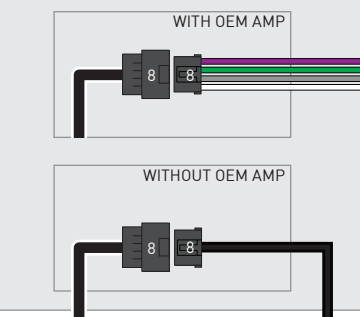

STEP 3

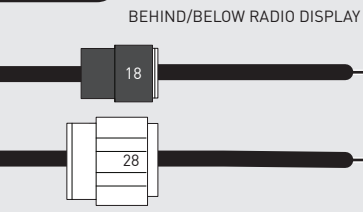

STEP 4

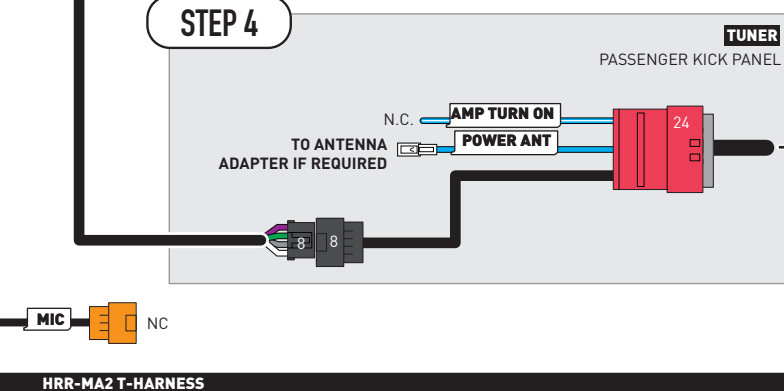

STEP 6

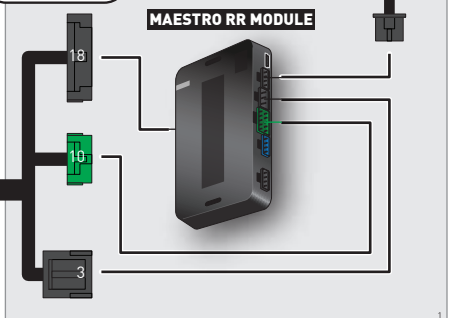

NOT REQUIRED

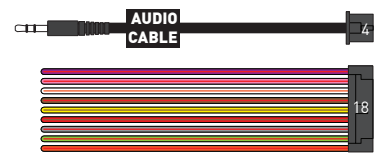
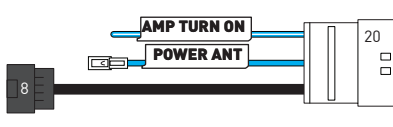
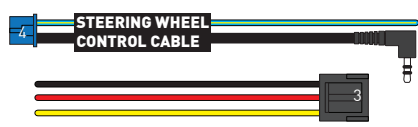

RADIO WIRE REFERENCE CHART

MA2 T-harness Wire Description	Polarity	Wire Color on Maestro T-Harness	Wire Color on Alpine cable	Wire Color on Kenwood cable	Wire Color on Pioneer cable	Wire Color on Sony cable
Illumination	(+)	Orange	N/A	Orange/White	Orange/White	Orange
Reverse Light*	(+)	Purple/White	Orange/White	Purple/White	Purple/White	Purple/White
E-Brake	(-)	Lt Green	Yellow/Blue	Lt Green	Lt Green	Lt Green
VSS (vehicle speed sensor)	(DATA)	Pink	Green/White	Pink	Pink	N/A

Head unit adapter wiring (optional accessory, sold separately)

ACC-HU-ALP1 Wire Description	Polarity	Wire Color on Adapter	Alpine Radio
VSS (vehicle speed sensor)	(DATA)	Green/White	Green/White

ACC-HU-KEN1 Wire Description	Polarity	Wire Color on Adapter	Kenwood Radio
CAM	(+)	Green/Red	Refer to camera/radio manual
CAM	(-)	Green/White	Refer to camera/radio manual
Steering Wheel Controls	(DATA)	Blue/Yellow	n/a

ACC-HU-KEN2 Wire Description	Polarity	Wire Color on Adapter	Kenwood Radio
E-Brake	(-)	LtGreen	LtGreen
Reverse Light*	(+)	Purple/White	Purple/White
Steering Wheel Controls	(DATA)	Blue/Yellow	n/a

* Reverse light wire: Only connect to radio or module damage will occur.

MODULE DIAGNOSTICS



LED 1 Module/Firmware status	LED 2 (RR2) Bluetooth activity	LED STATUS	DIAGNOSTIC
• or •		RED or GREEN flashing	LED flashes 1 or more times, either red or green, when a steering wheel button is pressed : normal operation.
•		1 RED flash	Module has no firmware. Flash module using Weblink Desktop and log in. Do <u>NOT</u> use DEMO MODE.
•		2 RED flashes	Problem detected. Consult troubleshooting table.
•		1 GREEN flash	After radio boots up : Normal operation.
	•	3 GREEN flashes	Bluetooth is activated. Turns off after one minute: Normal operation.
•	•	OFF	Normal operation (inactive).

VIDEO HELP		Installation, product information, vehicle specific videos.
VERIFY FLASH		Last flash information, steering control configuration, vehicle information.
WEBLINK		Software to program module.

TROUBLESHOOTING TABLE

PROBLEM	SOLUTION
Gauges do not work, radio shows OBD2 Error 1 or Error 2.	If anything is connected to the OBD2 or CAN wires of vehicle (programmer, throttle controller, insurance tracker, etc.) try unplugging it to see if gauges work. If gauges work without it installed, call tech support for options. Reset the RR.
CX-5 and Mazda3 No audio after installing new radio. Factory radio no longer has sound.	Check 7.5 amp "AUDIO 2" fuse located under the hood.
The light on the Maestro is flashing RED ONCE .	There is no firmware on the module. Flash the RR module using Weblink Desktop and log in. Do NOT use DEMO MODE.
The light on the Maestro is blinking RED TWICE and the radio IS turning on.	Ensure the 4-pin data cable is connected between the radio and the RR, and that it is plugged into the black port on the Maestro RR. The red and blue ports on the RR should be empty. Make sure the correct radio model and serial number were entered during the flash. Verify the radio's serial number entered during the flash matches what is listed on the radio screen. This can be found in the settings of the radio, listed as Device Id, Device Number, or Serial Number.
The light on the Maestro is blinking RED TWICE but the radio is NOT turning on.	If installing a modular radio and it is not turning on, ensure the screen is secured and any trim pieces on the radio have been installed fully. Not installing these fully will prevent radio from powering up and show a 2x red error as well. Test red and yellow wires for DC voltage at radio using a multimeter. Contact support if no voltage on red or yellow.

MAESTRO RR RESET PROCEDURE:

Turn the key to the OFF position, then disconnect all connectors from the module.

Press and hold the module's programming button and connect all the connectors back to the module. Wait, the module's LED will flash RED rapidly (this may take up to 10 seconds).

Release the programming button. Wait, the LED will turn solid GREEN for 2 seconds to show the reset was successful.

TECHNICAL ASSISTANCE

Phone: 1-866-427-2999

Email: maestro.support@idatalink.com

Web: maestro.idatalink.com/support add www.12voldata.com/forum/

IMPORTANT: To ensure proper operation, the aftermarket radio needs to have the latest firmware from the manufacturer. Please visit the radio manufacturer's website and look for any updates pertaining to your radio.

RETAINS STEERING WHEEL CONTROLS, VEHICLE SETTINGS, AND MORE!



PRODUCTS REQUIRED

iDataLink Maestro RR or RR2 Radio Replacement Interface
iDataLink Maestro HRR-MA2 Installation Harness

PROGRAMMED FIRMWARE

ADS-RR(SR)-MA1-DS

ADDITIONAL RESOURCES

[Maestro RR2 Programmable Outputs Guide](#)

OPTIONAL ACCESSORIES

K40[™]
ELECTRONICS
ESCORT

Click here for:
[Radar Installation Guides](#)

ANTENNA ADAPTER (MAY BE REQUIRED)

HEAD UNIT ADAPTER:
ACC-HU-PI01, SON1, KEN1, KEN2, ALP1

WELCOME

Congratulations on the purchase of your iDatalink Maestro RR Radio replacement solution. You are now a few simple steps away from enjoying your new car radio with enhanced features.

Before starting your installation, please ensure that your iDatalink Maestro module is programmed with the correct firmware for your vehicle and that you carefully review the install guide.

Please note that Maestro RR will only retain functionalities that were originally available in the vehicle.

NEED HELP?

 1 866 427-2999

 maestro.support@idatalink.com

 maestro.idatalink.com/support
www.12voltdata.com/forum

TABLE OF CONTENTS

Installation Instructions	3
Wiring Diagram	4
Radio Wire Reference Chart	5
Module Diagnostics	6
Troubleshooting Table	7

INSTALLATION INSTRUCTIONS P1/1

STEP 1

- **Disconnect the negative battery terminal** (not doing so may blow the 7.5A audio fuse 2 under hood during the installation of the radio).
- Remove the factory radio

If using head unit adapter (sold separately), connect HRR-MA2 harness to adapter and skip to step 2.

- Unbox the aftermarket radio and locate its main harness.
- Cut and remove the black 20 pin connector from the HRR-MA2 T-harness and connect the wires, shown in the wiring diagram, from aftermarket radio main harness to the HRR-MA2 T-harness and match the wire functions.

Note: only connect purple/white wire to radio reverse input or module damage will occur.

STEP 2

If the vehicle DOES NOT have a factory amplifier:

- Plug in the extension harness to HRR-MA2 main harness 8-pin black connector.

If the vehicle DOES have a factory amplifier:

- Plug in the extension harness to 8-pin black connector of RCA cable.
- Connect the RCAs to the radio outputs: white/left front, gray/right front, green/left rear, purple/right rear.
- Route the extension harness to the radio tuner in the passenger kick panel.

STEP 3

- Connect both the 18-pin and 28-pin connectors of HRR-MA2 T-harness to the factory radio harness (at CMU, behind/below display).

STEP 4

- Connect the 20-pin adapter (white connector) to the factory radio tuner in the passenger kick panel.
- Connect the adapter's 8-pin black connector to the extension harness.
- Plug the blue POWER ANT terminal to amplified antenna adapter (if required).

STEP 5

- Plug the harnesses into the aftermarket radio.
- Connect the backup cam cable into the aftermarket radio (if equipped).
- Plug the antenna adapter (if required).
- Plug the Data cable to the data port of the aftermarket radio.

Note: On Pioneer radio, ensure that there is nothing plugged into the W/R port.

STEP 6

- Connect all the harnesses to the Maestro RR module.
- **Reconnect the negative battery terminal then test your installation.**

WIRING DIAGRAM

STEP 1

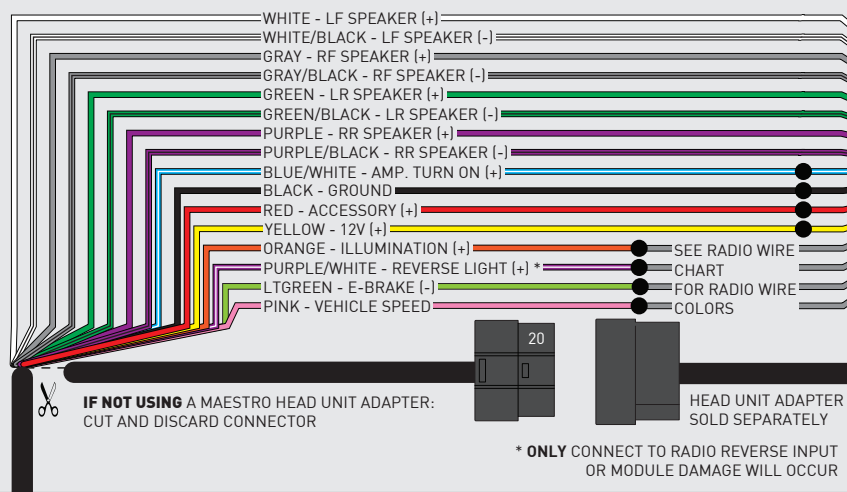

STEP 5

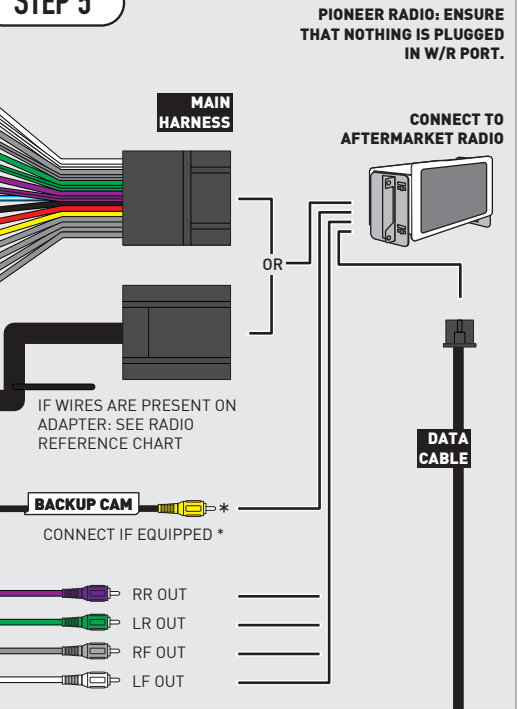

STEP 2

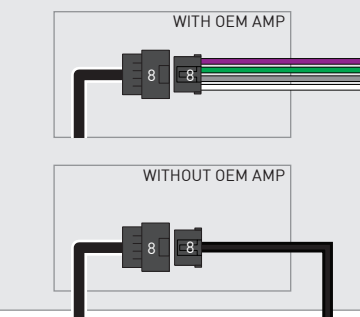

STEP 3

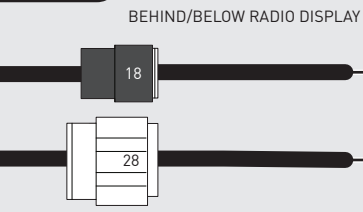

STEP 4

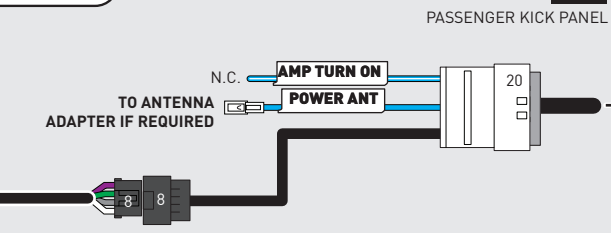

STEP 6

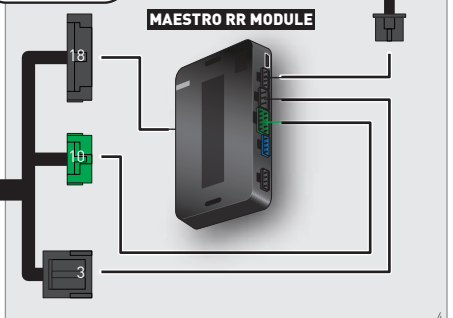

NOT REQUIRED

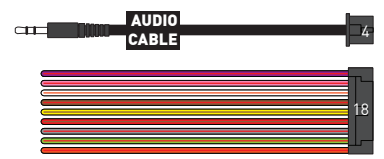
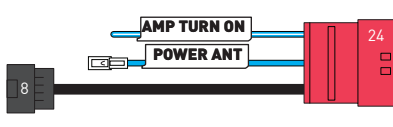
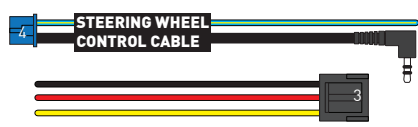

RADIO WIRE REFERENCE CHART

MA2 T-harness Wire Description	Polarity	Wire Color on Maestro T-Harness	Wire Color on Alpine cable	Wire Color on Kenwood cable	Wire Color on Pioneer cable	Wire Color on Sony cable
Illumination	(+)	Orange	N/A	Orange/White	Orange/White	Orange
Reverse Light*	(+)	Purple/White	Orange/White	Purple/White	Purple/White	Purple/White
E-Brake	(-)	Lt Green	Yellow/Blue	Lt Green	Lt Green	Lt Green
VSS (vehicle speed sensor)	(DATA)	Pink	Green/White	Pink	Pink	N/A

Head unit adapter wiring (optional accessory, sold separately)

ACC-HU-ALP1 Wire Description	Polarity	Wire Color on Adapter	Alpine Radio
VSS (vehicle speed sensor)	(DATA)	Green/White	Green/White

ACC-HU-KEN1 Wire Description	Polarity	Wire Color on Adapter	Kenwood Radio
CAM	(+)	Green/Red	Refer to camera/radio manual
CAM	(-)	Green/White	Refer to camera/radio manual
Steering Wheel Controls	(DATA)	Blue/Yellow	n/a

ACC-HU-KEN2 Wire Description	Polarity	Wire Color on Adapter	Kenwood Radio
E-Brake	(-)	LtGreen	LtGreen
Reverse Light*	(+)	Purple/White	Purple/White
Steering Wheel Controls	(DATA)	Blue/Yellow	n/a

* Reverse light wire: Only connect to radio or module damage will occur.

MODULE DIAGNOSTICS



LED 1 Module/Firmware status	LED 2 (RR2) Bluetooth activity	LED STATUS	DIAGNOSTIC
● or ●		RED or GREEN flashing	LED flashes 1 or more times, either red or green, when a steering wheel button is pressed : normal operation.
●		1 RED flash	Module has no firmware. Flash module using Weblink Desktop and log in. Do <u>NOT</u> use DEMO MODE.
●		2 RED flashes	Problem detected. Consult troubleshooting table.
●		1 GREEN flash	After radio boots up : Normal operation.
	●	3 GREEN flashes	Bluetooth is activated. Turns off after one minute: Normal operation.
●	●	OFF	Normal operation (inactive).

VIDEO HELP		Installation, product information, vehicle specific videos.
VERIFY FLASH		Last flash information, steering control configuration, vehicle information.
WEBLINK		Software to program module.

TROUBLESHOOTING TABLE

PROBLEM	SOLUTION
Gauges do not work, radio shows OBD2 Error 1 or Error 2.	If anything is connected to the OBD2 or CAN wires of vehicle (programmer, throttle controller, insurance tracker, etc.) try unplugging it to see if gauges work. If gauges work without it installed, call tech support for options. Reset the RR.
CX-5 and Mazda3 No audio after installing new radio. Factory radio no longer has sound.	Check 7.5 amp "AUDIO 2" fuse located under the hood.
The light on the Maestro is flashing RED ONCE .	There is no firmware on the module. Flash the RR module using Weblink Desktop and log in. Do NOT use DEMO MODE.
The light on the Maestro is blinking RED TWICE and the radio IS turning on.	Ensure the 4-pin data cable is connected between the radio and the RR, and that it is plugged into the black port on the Maestro RR. The red and blue ports on the RR should be empty. Make sure the correct radio model and serial number were entered during the flash. Verify the radio's serial number entered during the flash matches what is listed on the radio screen. This can be found in the settings of the radio, listed as Device Id, Device Number, or Serial Number.
The light on the Maestro is blinking RED TWICE but the radio is NOT turning on.	If installing a modular radio and it is not turning on, ensure the screen is secured and any trim pieces on the radio have been installed fully. Not installing these fully will prevent radio from powering up and show a 2x red error as well. Test red and yellow wires for DC voltage at radio using a multimeter. Contact support if no voltage on red or yellow.

MAESTRO RR RESET PROCEDURE:

Turn the key to the OFF position, then disconnect all connectors from the module.

Press and hold the module's programming button and connect all the connectors back to the module. Wait, the module's LED will flash RED rapidly (this may take up to 10 seconds).

Release the programming button. Wait, the LED will turn solid GREEN for 2 seconds to show the reset was successful.

TECHNICAL ASSISTANCE

Phone: 1-866-427-2999

Email: maestro.support@idatalink.com

Web: maestro.idatalink.com/support add www.12voldata.com/forum/

IMPORTANT: To ensure proper operation, the aftermarket radio needs to have the latest firmware from the manufacturer. Please visit the radio manufacturer's website and look for any updates pertaining to your radio.

RETAINS STEERING WHEEL CONTROLS, VEHICLE SETTINGS, AND MORE!



PRODUCTS REQUIRED

iDatalink Maestro RR or RR2 Radio Replacement Interface
iDatalink Maestro HRR-MA2 Installation Harness

PROGRAMMED FIRMWARE

ADS-RR(SR)-MA1-DS

ADDITIONAL RESOURCES

[Maestro RR2 Programmable Outputs Guide](#)

OPTIONAL ACCESSORIES

K40
ELECTRONICS
ESCORT

Click here for:
[Radar Installation Guides](#)

ANTENNA ADAPTER (MAY BE REQUIRED)

HEAD UNIT ADAPTER:
ACC-HU-PI01, SON1, KEN1, KEN2, ALP1

WELCOME

Congratulations on the purchase of your iDatalink Maestro RR Radio replacement solution. You are now a few simple steps away from enjoying your new car radio with enhanced features.

Before starting your installation, please ensure that your iDatalink Maestro module is programmed with the correct firmware for your vehicle and that you carefully review the install guide.

Please note that Maestro RR will only retain functionalities that were originally available in the vehicle.

NEED HELP?

 1 866 427-2999

 maestro.support@idatalink.com

 maestro.idatalink.com/support
www.12voltdata.com/forum

TABLE OF CONTENTS

Installation Instructions	3
Wiring Diagram	4
Radio Wire Reference Chart	5
Module Diagnostics	6
Troubleshooting Table	7

INSTALLATION INSTRUCTIONS P1/1

STEP 1

- **Disconnect the negative battery terminal** (not doing so may blow the 7.5A audio fuse 2 under hood during the installation of the radio).
- Remove the factory radio

If using head unit adapter (sold separately), connect HRR-MA2 harness to adapter and skip to step 2.

- Unbox the aftermarket radio and locate its main harness.
- Cut and remove the black 20 pin connector from the HRR-MA2 T-harness and connect the wires, shown in the wiring diagram, from aftermarket radio main harness to the HRR-MA2 T-harness and match the wire functions.

Note: only connect purple/white wire to radio reverse input or module damage will occur.

STEP 2

If the vehicle DOES NOT have a factory amplifier:

- Plug in the extension harness to HRR-MA2 main harness 8-pin black connector.

If the vehicle DOES have a factory amplifier:

- Plug in the extension harness to 8-pin black connector of RCA cable.
- Connect the RCAs to the radio outputs: white/left front, gray/right front, green/left rear, purple/right rear.
- Route the extension harness to the radio tuner in the passenger kick panel.

STEP 3

- Connect both the 18-pin and 28-pin connectors of HRR-MA2 T-harness to the factory radio harness (at CMU, behind/below display).

STEP 4

- Connect the 24-pin adapter (red connector) to the factory radio tuner in the passenger kick panel.
- Connect the adapter's 8-pin black connector to the extension harness.
- Plug the blue POWER ANT terminal to amplified antenna adapter (if required).

STEP 5

- Plug the harnesses into the aftermarket radio.
- Connect the backup cam cable into the aftermarket radio (if equipped).
- Plug the antenna adapter (if required).
- Plug the Data cable to the data port of the aftermarket radio.

Note: On Pioneer radio, ensure that there is nothing plugged into the W/R port.

STEP 6

- Connect all the harnesses to the Maestro RR module.
- **Reconnect the negative battery terminal then test your installation.**

WIRING DIAGRAM

STEP 1

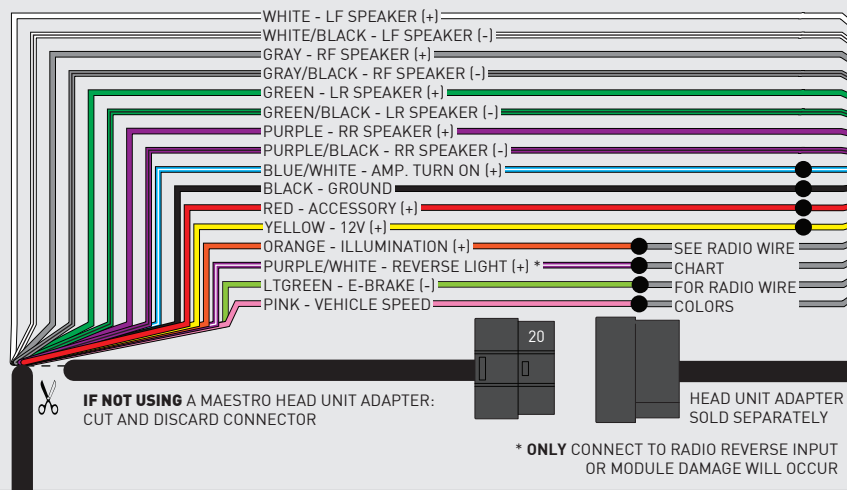

STEP 5

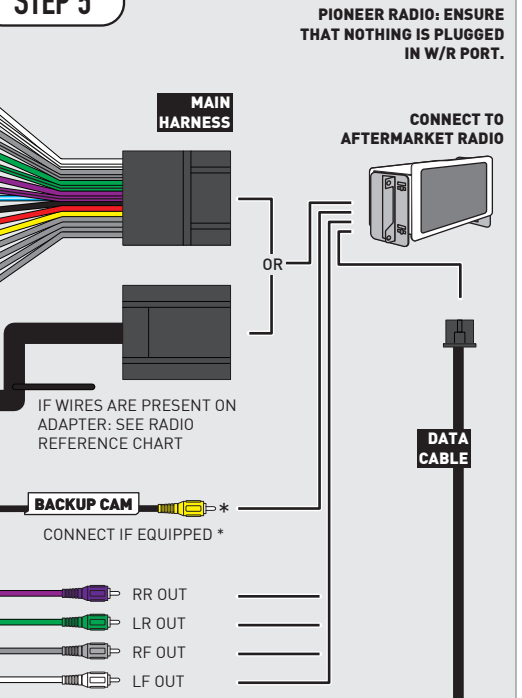

STEP 2

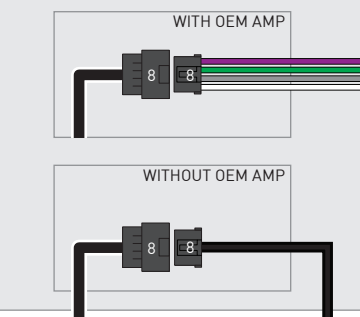

STEP 3

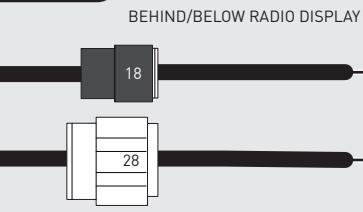

STEP 4

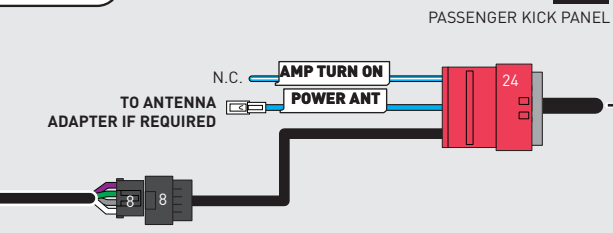

STEP 6

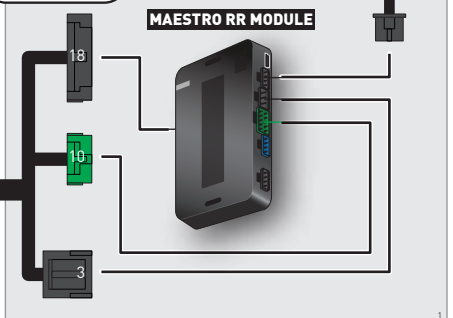

NOT REQUIRED

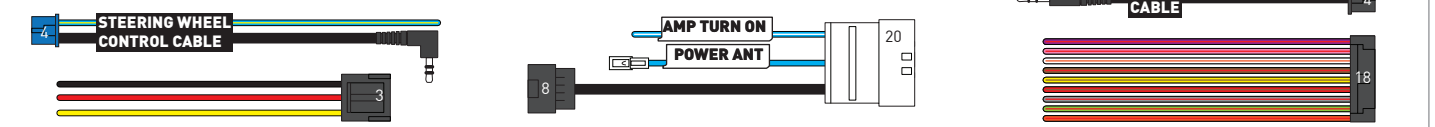

RADIO WIRE REFERENCE CHART

MA2 T-harness Wire Description	Polarity	Wire Color on Maestro T-Harness	Wire Color on Alpine cable	Wire Color on Kenwood cable	Wire Color on Pioneer cable	Wire Color on Sony cable
Illumination	(+)	Orange	N/A	Orange/White	Orange/White	Orange
Reverse Light*	(+)	Purple/White	Orange/White	Purple/White	Purple/White	Purple/White
E-Brake	(-)	Lt Green	Yellow/Blue	Lt Green	Lt Green	Lt Green
VSS (vehicle speed sensor)	(DATA)	Pink	Green/White	Pink	Pink	N/A

Head unit adapter wiring (optional accessory, sold separately)

ACC-HU-ALP1 Wire Description	Polarity	Wire Color on Adapter	Alpine Radio
VSS (vehicle speed sensor)	(DATA)	Green/White	Green/White

ACC-HU-KEN1 Wire Description	Polarity	Wire Color on Adapter	Kenwood Radio
CAM	(+)	Green/Red	Refer to camera/radio manual
CAM	(-)	Green/White	Refer to camera/radio manual
Steering Wheel Controls	(DATA)	Blue/Yellow	n/a

ACC-HU-KEN2 Wire Description	Polarity	Wire Color on Adapter	Kenwood Radio
E-Brake	(-)	LtGreen	LtGreen
Reverse Light*	(+)	Purple/White	Purple/White
Steering Wheel Controls	(DATA)	Blue/Yellow	n/a

* Reverse light wire: Only connect to radio or module damage will occur.

MODULE DIAGNOSTICS



LED 1 Module/Firmware status	LED 2 (RR2) Bluetooth activity	LED STATUS	DIAGNOSTIC
● or ●		RED or GREEN flashing	LED flashes 1 or more times, either red or green, when a steering wheel button is pressed : normal operation.
●		1 RED flash	Module has no firmware. Flash module using Weblink Desktop and log in. Do <u>NOT</u> use DEMO MODE.
●		2 RED flashes	Problem detected. Consult troubleshooting table.
●		1 GREEN flash	After radio boots up : Normal operation.
	●	3 GREEN flashes	Bluetooth is activated. Turns off after one minute: Normal operation.
●	●	OFF	Normal operation (inactive).

VIDEO HELP		Installation, product information, vehicle specific videos.
VERIFY FLASH		Last flash information, steering control configuration, vehicle information.
WEBLINK		Software to program module.

TROUBLESHOOTING TABLE

PROBLEM	SOLUTION
Gauges do not work, radio shows OBD2 Error 1 or Error 2.	If anything is connected to the OBD2 or CAN wires of vehicle (programmer, throttle controller, insurance tracker, etc.) try unplugging it to see if gauges work. If gauges work without it installed, call tech support for options. Reset the RR.
CX-5 and Mazda3 No audio after installing new radio. Factory radio no longer has sound.	Check 7.5 amp "AUDIO 2" fuse located under the hood.
The light on the Maestro is flashing RED ONCE .	There is no firmware on the module. Flash the RR module using Weblink Desktop and log in. Do NOT use DEMO MODE.
The light on the Maestro is blinking RED TWICE and the radio IS turning on.	Ensure the 4-pin data cable is connected between the radio and the RR, and that it is plugged into the black port on the Maestro RR. The red and blue ports on the RR should be empty. Make sure the correct radio model and serial number were entered during the flash. Verify the radio's serial number entered during the flash matches what is listed on the radio screen. This can be found in the settings of the radio, listed as Device Id, Device Number, or Serial Number.
The light on the Maestro is blinking RED TWICE but the radio is NOT turning on.	If installing a modular radio and it is not turning on, ensure the screen is secured and any trim pieces on the radio have been installed fully. Not installing these fully will prevent radio from powering up and show a 2x red error as well. Test red and yellow wires for DC voltage at radio using a multimeter. Contact support if no voltage on red or yellow.

MAESTRO RR RESET PROCEDURE:

Turn the key to the OFF position, then disconnect all connectors from the module.

Press and hold the module's programming button and connect all the connectors back to the module. Wait, the module's LED will flash RED rapidly (this may take up to 10 seconds).

Release the programming button. Wait, the LED will turn solid GREEN for 2 seconds to show the reset was successful.

TECHNICAL ASSISTANCE

Phone: 1-866-427-2999

Email: maestro.support@idatalink.com

Web: maestro.idatalink.com/support add www.12voldata.com/forum/

IMPORTANT: To ensure proper operation, the aftermarket radio needs to have the latest firmware from the manufacturer. Please visit the radio manufacturer's website and look for any updates pertaining to your radio.

RETAINS STEERING WHEEL CONTROLS, VEHICLE SETTINGS, AND MORE!



PRODUCTS REQUIRED

iDataLink Maestro RR or RR2 Radio Replacement Interface
iDataLink Maestro HRR-MA2 Installation Harness

PROGRAMMED FIRMWARE

ADS-RR(SR)-MA1-DS

ADDITIONAL RESOURCES

[Maestro RR2 Programmable Outputs Guide](#)

OPTIONAL ACCESSORIES

K40[™]
ELECTRONICS
ESCORT

Click here for:
[Radar Installation Guides](#)

ANTENNA ADAPTER (MAY BE REQUIRED)

HEAD UNIT ADAPTER:
ACC-HU-PI01, SON1, KEN1, KEN2, ALP1

WELCOME

Congratulations on the purchase of your iDatalink Maestro RR Radio replacement solution. You are now a few simple steps away from enjoying your new car radio with enhanced features.

Before starting your installation, please ensure that your iDatalink Maestro module is programmed with the correct firmware for your vehicle and that you carefully review the install guide.

Please note that Maestro RR will only retain functionalities that were originally available in the vehicle.

NEED HELP?

 1 866 427-2999

 maestro.support@idatalink.com

 maestro.idatalink.com/support
www.12voltdata.com/forum

TABLE OF CONTENTS

Installation Instructions	3
Wiring Diagram	4
Radio Wire Reference Chart	5
Module Diagnostics	6
Troubleshooting Table	7

INSTALLATION INSTRUCTIONS P1/1

STEP 1

- **Disconnect the negative battery terminal** (not doing so may blow the 7.5A audio fuse 2 under hood during the installation of the radio).
- Remove the factory radio

If using head unit adapter (sold separately), connect HRR-MA2 harness to adapter and skip to step 2.

- Unbox the aftermarket radio and locate its main harness.
- Cut and remove the black 20 pin connector from the HRR-MA2 T-harness and connect the wires, shown in the wiring diagram, from aftermarket radio main harness to the HRR-MA2 T-harness and match the wire functions.

Note: only connect purple/white wire to radio reverse input or module damage will occur.

STEP 2

If the vehicle DOES NOT have a factory amplifier:

- Plug in the extension harness to HRR-MA2 main harness 8-pin black connector.

If the vehicle DOES have a factory amplifier:

- Plug in the extension harness to 8-pin black connector of RCA cable.
- Connect the RCAs to the radio outputs: white/left front, gray/right front, green/left rear, purple/right rear.
- Route the extension harness to the radio tuner in the passenger kick panel.

STEP 3

- Connect both the 18-pin and 28-pin connectors of HRR-MA2 T-harness to the factory radio harness (at CMU, behind/below display).

STEP 4

- Connect the 20-pin adapter (white connector) or the 24-pin adapter (red connector) to the factory radio tuner in the passenger kick panel.
- Connect the adapter's 8-pin black connector to the extension harness.
- Plug the blue POWER ANT terminal to amplified antenna adapter (if required).

STEP 5

- Plug the harnesses into the aftermarket radio.
- Connect the backup cam cable into the aftermarket radio (if equipped).
- Plug the antenna adapter (if required).
- Plug the Data cable to the data port of the aftermarket radio.

Note: On Pioneer radio, ensure that there is nothing plugged into the W/R port.

STEP 6

- Connect all the harnesses to the Maestro RR module.
- **Reconnect the negative battery terminal then test your installation.**

WIRING DIAGRAM

STEP 1

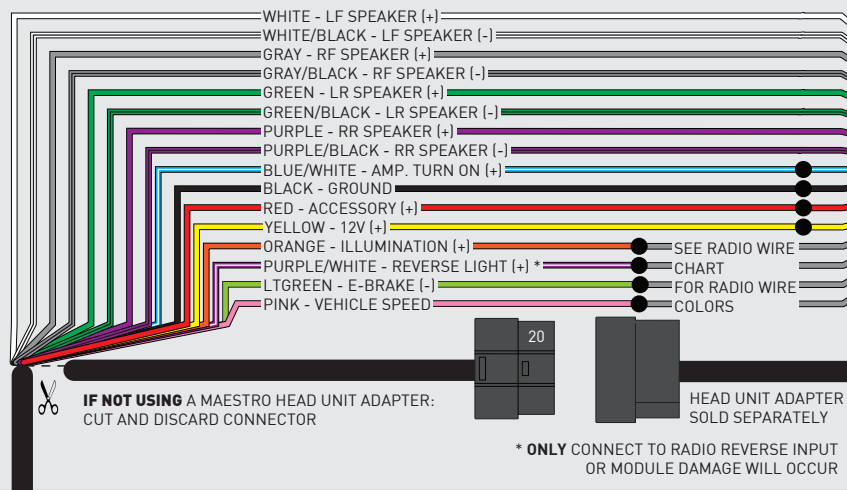

STEP 5

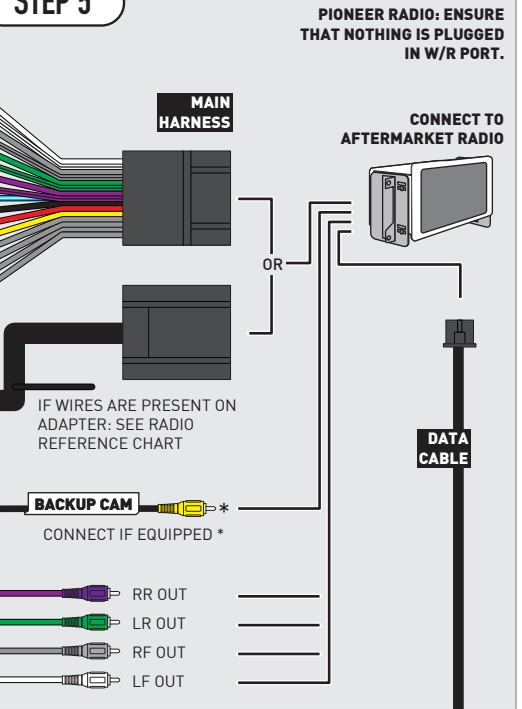

STEP 2

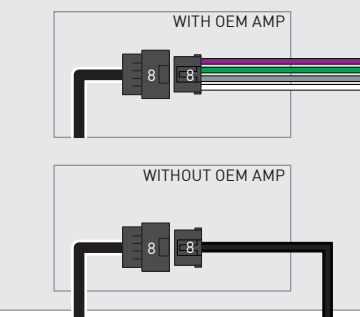

STEP 3

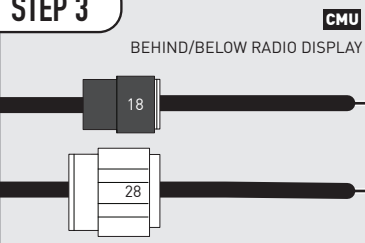

STEP 4

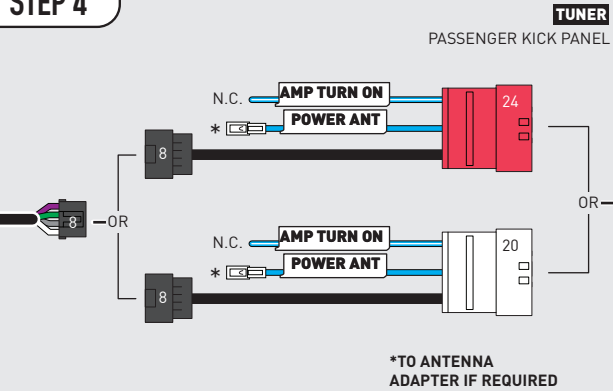

STEP 6

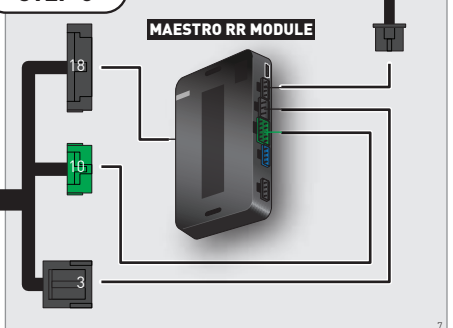

NOT REQUIRED

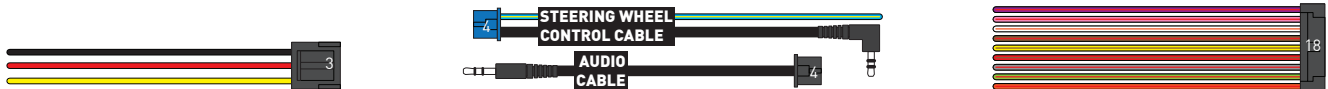

RADIO WIRE REFERENCE CHART

MA2 T-harness Wire Description	Polarity	Wire Color on Maestro T-Harness	Wire Color on Alpine cable	Wire Color on Kenwood cable	Wire Color on Pioneer cable	Wire Color on Sony cable
Illumination	(+)	Orange	N/A	Orange/White	Orange/White	Orange
Reverse Light*	(+)	Purple/White	Orange/White	Purple/White	Purple/White	Purple/White
E-Brake	(-)	Lt Green	Yellow/Blue	Lt Green	Lt Green	Lt Green
VSS (vehicle speed sensor)	(DATA)	Pink	Green/White	Pink	Pink	N/A

Head unit adapter wiring (optional accessory, sold separately)

ACC-HU-ALP1 Wire Description	Polarity	Wire Color on Adapter	Alpine Radio
VSS (vehicle speed sensor)	(DATA)	Green/White	Green/White

ACC-HU-KEN1 Wire Description	Polarity	Wire Color on Adapter	Kenwood Radio
CAM	(+)	Green/Red	Refer to camera/radio manual
CAM	(-)	Green/White	Refer to camera/radio manual
Steering Wheel Controls	(DATA)	Blue/Yellow	n/a

ACC-HU-KEN2 Wire Description	Polarity	Wire Color on Adapter	Kenwood Radio
E-Brake	(-)	LtGreen	LtGreen
Reverse Light*	(+)	Purple/White	Purple/White
Steering Wheel Controls	(DATA)	Blue/Yellow	n/a

* Reverse light wire: Only connect to radio or module damage will occur.

MODULE DIAGNOSTICS



LED 1 Module/Firmware status	LED 2 (RR2) Bluetooth activity	LED STATUS	DIAGNOSTIC
● or ●		RED or GREEN flashing	LED flashes 1 or more times, either red or green, when a steering wheel button is pressed : normal operation.
●		1 RED flash	Module has no firmware. Flash module using Weblink Desktop and log in. Do <u>NOT</u> use DEMO MODE.
●		2 RED flashes	Problem detected. Consult troubleshooting table.
●		1 GREEN flash	After radio boots up : Normal operation.
	●	3 GREEN flashes	Bluetooth is activated. Turns off after one minute: Normal operation.
●	●	OFF	Normal operation (inactive).

VIDEO HELP		Installation, product information, vehicle specific videos.
VERIFY FLASH		Last flash information, steering control configuration, vehicle information.
WEBLINK		Software to program module.

TROUBLESHOOTING TABLE

PROBLEM	SOLUTION
Gauges do not work, radio shows OBD2 Error 1 or Error 2.	If anything is connected to the OBD2 or CAN wires of vehicle (programmer, throttle controller, insurance tracker, etc.) try unplugging it to see if gauges work. If gauges work without it installed, call tech support for options. Reset the RR.
CX-5 and Mazda3 No audio after installing new radio. Factory radio no longer has sound.	Check 7.5 amp "AUDIO 2" fuse located under the hood.
The light on the Maestro is flashing RED ONCE .	There is no firmware on the module. Flash the RR module using Weblink Desktop and log in. Do NOT use DEMO MODE.
The light on the Maestro is blinking RED TWICE and the radio IS turning on.	Ensure the 4-pin data cable is connected between the radio and the RR, and that it is plugged into the black port on the Maestro RR. The red and blue ports on the RR should be empty. Make sure the correct radio model and serial number were entered during the flash. Verify the radio's serial number entered during the flash matches what is listed on the radio screen. This can be found in the settings of the radio, listed as Device Id, Device Number, or Serial Number.
The light on the Maestro is blinking RED TWICE but the radio is NOT turning on.	If installing a modular radio and it is not turning on, ensure the screen is secured and any trim pieces on the radio have been installed fully. Not installing these fully will prevent radio from powering up and show a 2x red error as well. Test red and yellow wires for DC voltage at radio using a multimeter. Contact support if no voltage on red or yellow.

MAESTRO RR RESET PROCEDURE:

Turn the key to the OFF position, then disconnect all connectors from the module.

Press and hold the module's programming button and connect all the connectors back to the module. Wait, the module's LED will flash RED rapidly (this may take up to 10 seconds).

Release the programming button. Wait, the LED will turn solid GREEN for 2 seconds to show the reset was successful.

TECHNICAL ASSISTANCE

Phone: 1-866-427-2999

Email: maestro.support@idatalink.com

Web: maestro.idatalink.com/support add www.12voldata.com/forum/

IMPORTANT: To ensure proper operation, the aftermarket radio needs to have the latest firmware from the manufacturer. Please visit the radio manufacturer's website and look for any updates pertaining to your radio.

RETAINS STEERING WHEEL CONTROLS, VEHICLE SETTINGS, AND MORE!



PRODUCTS REQUIRED

iDatalink Maestro RR or RR2 Radio Replacement Interface
iDatalink Maestro HRR-MA2 Installation Harness

PROGRAMMED FIRMWARE

ADS-RR(SR)-MA1-DS

ADDITIONAL RESOURCES

[Maestro RR2 Programmable Outputs Guide](#)

OPTIONAL ACCESSORIES

K40[™]
ELECTRONICS
ESCORT

Click here for:
[Radar Installation Guides](#)

ANTENNA ADAPTER (MAY BE REQUIRED)

HEAD UNIT ADAPTER:
ACC-HU-PI01, SON1, KEN1, KEN2, ALP1

WELCOME

Congratulations on the purchase of your iDatalink Maestro RR Radio replacement solution. You are now a few simple steps away from enjoying your new car radio with enhanced features.

Before starting your installation, please ensure that your iDatalink Maestro module is programmed with the correct firmware for your vehicle and that you carefully review the install guide.

Please note that Maestro RR will only retain functionalities that were originally available in the vehicle.

NEED HELP?

 1 866 427-2999

 maestro.support@idatalink.com

 maestro.idatalink.com/support
www.12voltdata.com/forum

TABLE OF CONTENTS

Installation Instructions	3
Wiring Diagram	4
Radio Wire Reference Chart	5
Module Diagnostics	6
Troubleshooting Table	7

INSTALLATION INSTRUCTIONS P1/1

STEP 1

- **Disconnect the negative battery terminal** (not doing so may blow the 7.5A audio fuse 2 under hood during the installation of the radio).
- Remove the factory radio

If using head unit adapter (sold separately), connect HRR-MA2 harness to adapter and skip to step 2.

- Unbox the aftermarket radio and locate its main harness.
- Cut and remove the black 20 pin connector from the HRR-MA2 T-harness and connect the wires, shown in the wiring diagram, from aftermarket radio main harness to the HRR-MA2 T-harness and match the wire functions.

Note: only connect purple/white wire to radio reverse input or module damage will occur.

STEP 2

If the vehicle DOES NOT have a factory amplifier:

- Plug in the extension harness to HRR-MA2 main harness 8-pin black connector.

If the vehicle DOES have a factory amplifier:

- Plug in the extension harness to 8-pin black connector of RCA cable.
- Connect the RCAs to the radio outputs: white/left front, gray/right front, green/left rear, purple/right rear.
- Route the extension harness to the radio tuner in the passenger kick panel.

STEP 3

- Connect both the 18-pin and 28-pin connectors of HRR-MA2 T-harness to the factory radio harness (at CMU, behind/below display).

STEP 4

- Connect the 20-pin adapter (white connector) to the factory radio tuner in the passenger kick panel.
- Connect the adapter's 8-pin black connector to the extension harness.
- Plug the blue POWER ANT terminal to amplified antenna adapter (if required).

STEP 5

- Plug the harnesses into the aftermarket radio.
- Connect the backup cam cable into the aftermarket radio (if equipped).
- Plug the antenna adapter (if required).
- Plug the Data cable to the data port of the aftermarket radio.

Note: On Pioneer radio, ensure that there is nothing plugged into the W/R port.

STEP 6

- Connect all the harnesses to the Maestro RR module.
- **Reconnect the negative battery terminal then test your installation.**

WIRING DIAGRAM

STEP 1

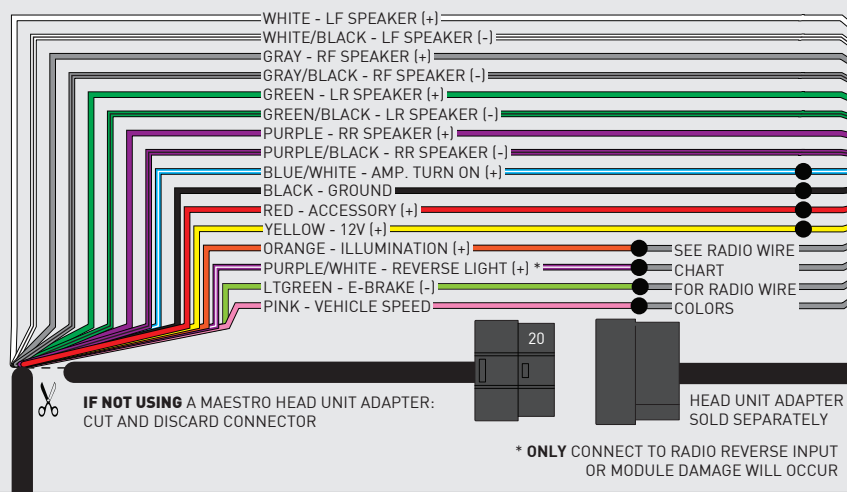

STEP 5

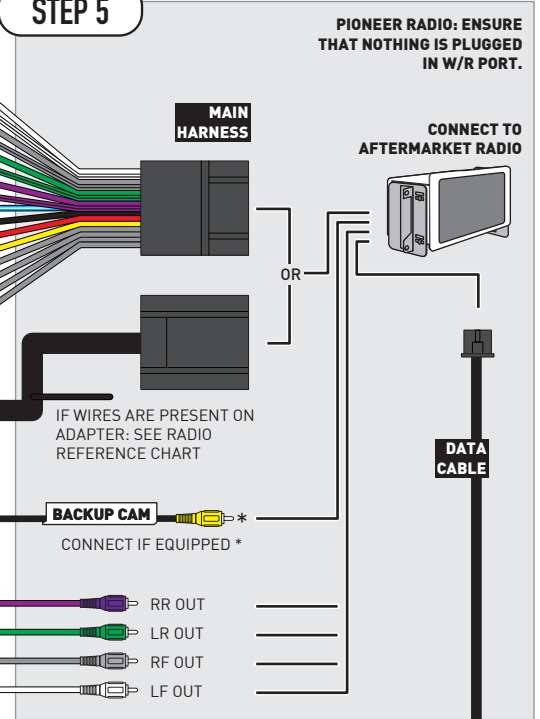

STEP 2

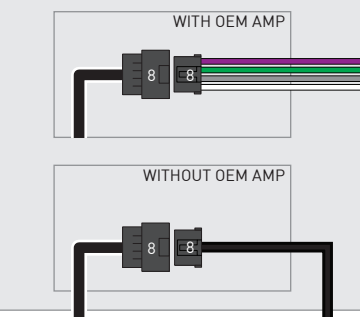

STEP 3

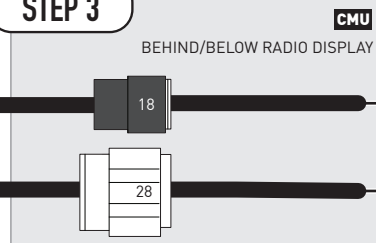

STEP 4

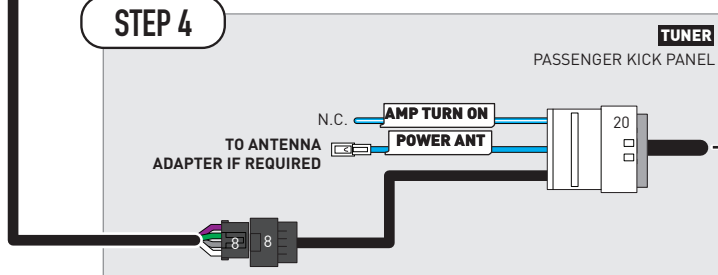

STEP 6

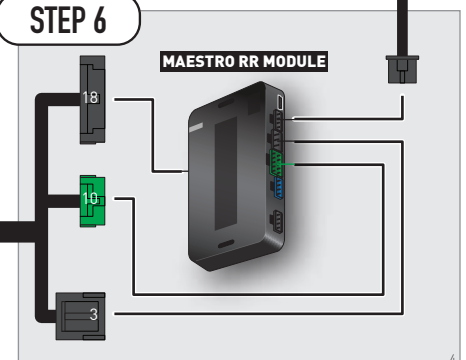

NOT REQUIRED

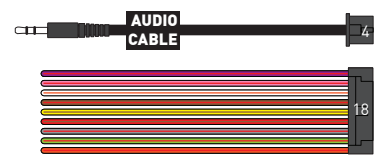
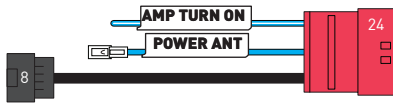
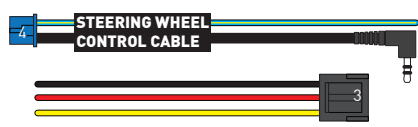

RADIO WIRE REFERENCE CHART

MA2 T-harness Wire Description	Polarity	Wire Color on Maestro T-Harness	Wire Color on Alpine cable	Wire Color on Kenwood cable	Wire Color on Pioneer cable	Wire Color on Sony cable
Illumination	(+)	Orange	N/A	Orange/White	Orange/White	Orange
Reverse Light*	(+)	Purple/White	Orange/White	Purple/White	Purple/White	Purple/White
E-Brake	(-)	Lt Green	Yellow/Blue	Lt Green	Lt Green	Lt Green
VSS (vehicle speed sensor)	(DATA)	Pink	Green/White	Pink	Pink	N/A

Head unit adapter wiring (optional accessory, sold separately)

ACC-HU-ALP1 Wire Description	Polarity	Wire Color on Adapter	Alpine Radio
VSS (vehicle speed sensor)	(DATA)	Green/White	Green/White

ACC-HU-KEN1 Wire Description	Polarity	Wire Color on Adapter	Kenwood Radio
CAM	(+)	Green/Red	Refer to camera/radio manual
CAM	(-)	Green/White	Refer to camera/radio manual
Steering Wheel Controls	(DATA)	Blue/Yellow	n/a

ACC-HU-KEN2 Wire Description	Polarity	Wire Color on Adapter	Kenwood Radio
E-Brake	(-)	LtGreen	LtGreen
Reverse Light*	(+)	Purple/White	Purple/White
Steering Wheel Controls	(DATA)	Blue/Yellow	n/a

* Reverse light wire: Only connect to radio or module damage will occur.

MODULE DIAGNOSTICS



LED 1 Module/Firmware status	LED 2 (RR2) Bluetooth activity	LED STATUS	DIAGNOSTIC
● or ●		RED or GREEN flashing	LED flashes 1 or more times, either red or green, when a steering wheel button is pressed : normal operation.
●		1 RED flash	Module has no firmware. Flash module using Weblink Desktop and log in. Do <u>NOT</u> use DEMO MODE.
●		2 RED flashes	Problem detected. Consult troubleshooting table.
●		1 GREEN flash	After radio boots up : Normal operation.
	●	3 GREEN flashes	Bluetooth is activated. Turns off after one minute: Normal operation.
●	●	OFF	Normal operation (inactive).

VIDEO HELP		Installation, product information, vehicle specific videos.
VERIFY FLASH		Last flash information, steering control configuration, vehicle information.
WEBLINK		Software to program module.

TROUBLESHOOTING TABLE

PROBLEM	SOLUTION
Gauges do not work, radio shows OBD2 Error 1 or Error 2.	If anything is connected to the OBD2 or CAN wires of vehicle (programmer, throttle controller, insurance tracker, etc.) try unplugging it to see if gauges work. If gauges work without it installed, call tech support for options. Reset the RR.
CX-5 and Mazda3 No audio after installing new radio. Factory radio no longer has sound.	Check 7.5 amp "AUDIO 2" fuse located under the hood.
The light on the Maestro is flashing RED ONCE .	There is no firmware on the module. Flash the RR module using Weblink Desktop and log in. Do NOT use DEMO MODE.
The light on the Maestro is blinking RED TWICE and the radio IS turning on.	Ensure the 4-pin data cable is connected between the radio and the RR, and that it is plugged into the black port on the Maestro RR. The red and blue ports on the RR should be empty. Make sure the correct radio model and serial number were entered during the flash. Verify the radio's serial number entered during the flash matches what is listed on the radio screen. This can be found in the settings of the radio, listed as Device Id, Device Number, or Serial Number.
The light on the Maestro is blinking RED TWICE but the radio is NOT turning on.	If installing a modular radio and it is not turning on, ensure the screen is secured and any trim pieces on the radio have been installed fully. Not installing these fully will prevent radio from powering up and show a 2x red error as well. Test red and yellow wires for DC voltage at radio using a multimeter. Contact support if no voltage on red or yellow.

MAESTRO RR RESET PROCEDURE:

Turn the key to the OFF position, then disconnect all connectors from the module.

Press and hold the module's programming button and connect all the connectors back to the module. Wait, the module's LED will flash RED rapidly (this may take up to 10 seconds).

Release the programming button. Wait, the LED will turn solid GREEN for 2 seconds to show the reset was successful.

TECHNICAL ASSISTANCE

Phone: 1-866-427-2999

Email: maestro.support@idatalink.com

Web: maestro.idatalink.com/support add www.12voldata.com/forum/

IMPORTANT: To ensure proper operation, the aftermarket radio needs to have the latest firmware from the manufacturer. Please visit the radio manufacturer's website and look for any updates pertaining to your radio.

2021

MAZDA CX-3

TOUCHSCREEN WITH AMPLIFIER

RETAINS STEERING WHEEL CONTROLS, VEHICLE SETTINGS, AND MORE!



PRODUCTS REQUIRED

iDataLink Maestro RR or RR2 Radio Replacement Interface
iDataLink Maestro HRR-MA2 Installation Harness

PROGRAMMED FIRMWARE

ADS-RR(SR)-MA1-DS

ADDITIONAL RESOURCES

[Maestro RR2 Programmable Outputs Guide](#)

OPTIONAL ACCESSORIES

K40[™]
ELECTRONICS
ESCORT

Click here for:
[Radar Installation Guides](#)

ANTENNA ADAPTER (MAY BE REQUIRED)

HEAD UNIT ADAPTER:
ACC-HU-PI01, SON1, KEN1, KEN2, ALP1

WELCOME

Congratulations on the purchase of your iDatalink Maestro RR Radio replacement solution. You are now a few simple steps away from enjoying your new car radio with enhanced features.

Before starting your installation, please ensure that your iDatalink Maestro module is programmed with the correct firmware for your vehicle and that you carefully review the install guide.

Please note that Maestro RR will only retain functionalities that were originally available in the vehicle.

NEED HELP?

 1 866 427-2999

 maestro.support@idatalink.com

 maestro.idatalink.com/support
www.12voltdata.com/forum

TABLE OF CONTENTS

Installation Instructions	3
Wiring Diagram	4
Radio Wire Reference Chart	5
Module Diagnostics	6
Troubleshooting Table	7

INSTALLATION INSTRUCTIONS P1/1

STEP 1

- **Disconnect the negative battery terminal** (not doing so may blow the 7.5A audio fuse 2 under hood during the installation of the radio).
- Remove the factory radio

If using head unit adapter (sold separately), connect HRR-MA2 harness to adapter and skip to step 2.

- Unbox the aftermarket radio and locate its main harness.
- Cut and remove the black 20 pin connector from the HRR-MA2 T-harness and connect the wires, shown in the wiring diagram, from aftermarket radio main harness to the HRR-MA2 T-harness and match the wire functions.

Note: only connect purple/white wire to radio reverse input or module damage will occur.

STEP 2

- Plug in the extension harness to 8-pin black connector of RCA cable.
- Connect the RCAs to the radio outputs: white/left front, gray/right front, green/left rear, purple/right rear.
- Route the extension harness to the radio tuner in the passenger kick panel.

STEP 3

- Connect both the 18-pin and 28-pin connectors of HRR-MA2 T-harness to the factory radio harness (at CMU, behind/below display).

STEP 4

- Connect the 20-pin adapter (white connector) to the factory radio tuner in the passenger kick panel.
- Connect the adapter's 8-pin black connector to the extension harness.
- Connect the adapter's AMP TURN ON blue/white wire to tuner's white wire at pin 6 of 32-pin white connector.
- Plug the blue POWER ANT terminal to amplified antenna adapter (if required).

STEP 5

- Plug the harnesses into the aftermarket radio.
- Connect the backup cam cable into the aftermarket radio (if equipped).
- Plug the antenna adapter (if required).
- Plug the Data cable to the data port of the aftermarket radio.

Note: On Pioneer radio, ensure that there is nothing plugged into the W/R port.

STEP 6

- Connect all the harnesses to the Maestro RR module.
- **Reconnect the negative battery terminal then test your installation.**

WIRING DIAGRAM

STEP 1

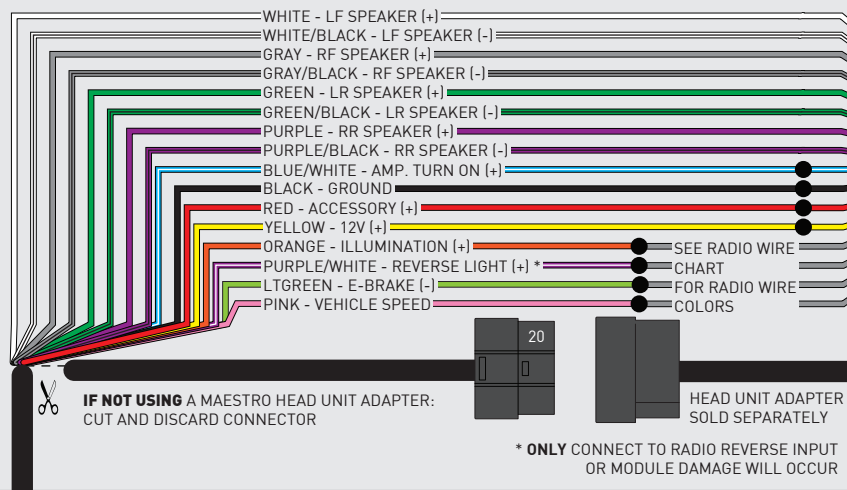

STEP 5

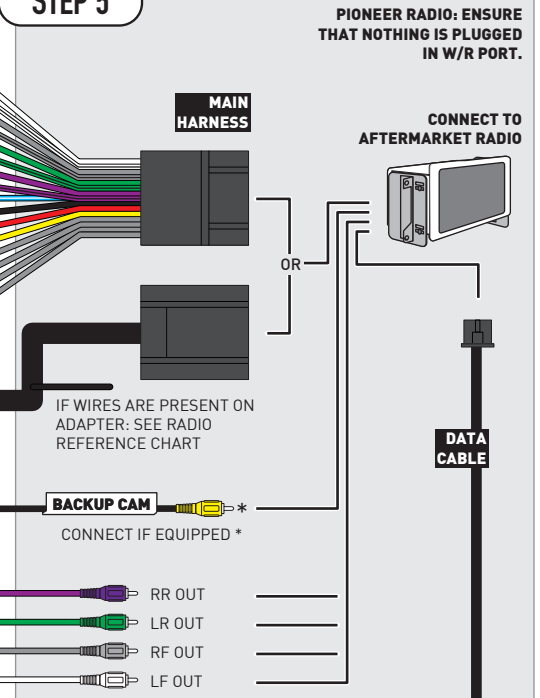

STEP 2



STEP 3

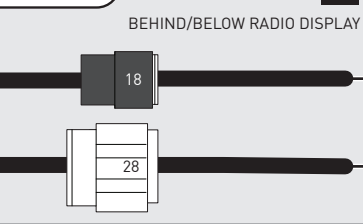

STEP 4

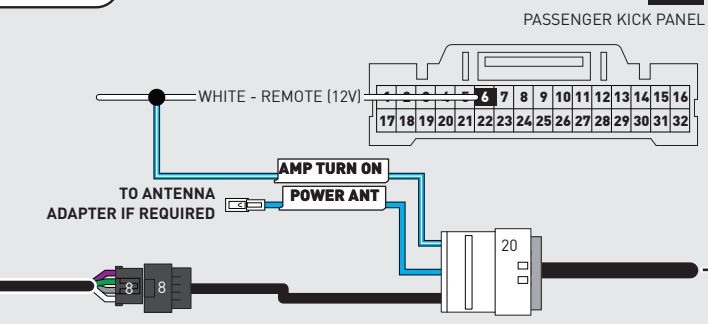

STEP 6

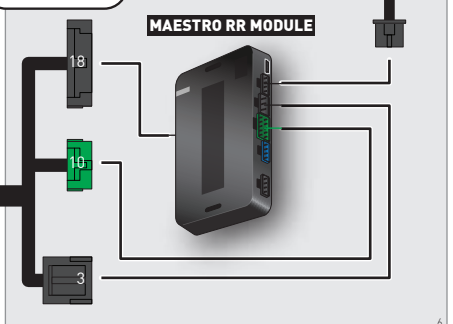

NOT REQUIRED

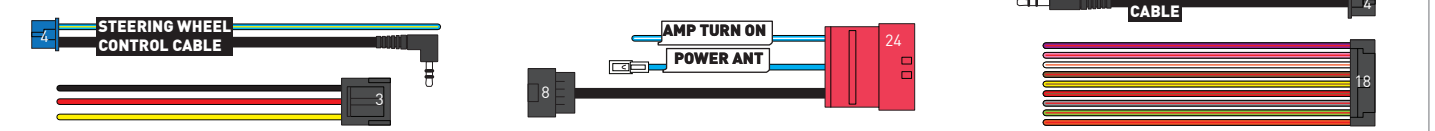

RADIO WIRE REFERENCE CHART

MA2 T-harness Wire Description	Polarity	Wire Color on Maestro T-Harness	Wire Color on Alpine cable	Wire Color on Kenwood cable	Wire Color on Pioneer cable	Wire Color on Sony cable
Illumination	(+)	Orange	N/A	Orange/White	Orange/White	Orange
Reverse Light*	(+)	Purple/White	Orange/White	Purple/White	Purple/White	Purple/White
E-Brake	(-)	Lt Green	Yellow/Blue	Lt Green	Lt Green	Lt Green
VSS (vehicle speed sensor)	(DATA)	Pink	Green/White	Pink	Pink	N/A

Head unit adapter wiring (optional accessory, sold separately)

ACC-HU-ALP1 Wire Description	Polarity	Wire Color on Adapter	Alpine Radio
VSS (vehicle speed sensor)	(DATA)	Green/White	Green/White

ACC-HU-KEN1 Wire Description	Polarity	Wire Color on Adapter	Kenwood Radio
CAM	(+)	Green/Red	Refer to camera/radio manual
CAM	(-)	Green/White	Refer to camera/radio manual
Steering Wheel Controls	(DATA)	Blue/Yellow	n/a

ACC-HU-KEN2 Wire Description	Polarity	Wire Color on Adapter	Kenwood Radio
E-Brake	(-)	LtGreen	LtGreen
Reverse Light*	(+)	Purple/White	Purple/White
Steering Wheel Controls	(DATA)	Blue/Yellow	n/a

* Reverse light wire: Only connect to radio or module damage will occur.

MODULE DIAGNOSTICS



LED 1 Module/Firmware status	LED 2 (RR2) Bluetooth activity	LED STATUS	DIAGNOSTIC
● or ●		RED or GREEN flashing	LED flashes 1 or more times, either red or green, when a steering wheel button is pressed : normal operation.
●		1 RED flash	Module has no firmware. Flash module using Weblink Desktop and log in. Do <u>NOT</u> use DEMO MODE.
●		2 RED flashes	Problem detected. Consult troubleshooting table.
●		1 GREEN flash	After radio boots up : Normal operation.
	●	3 GREEN flashes	Bluetooth is activated. Turns off after one minute: Normal operation.
●	●	OFF	Normal operation (inactive).

VIDEO HELP		Installation, product information, vehicle specific videos.
VERIFY FLASH		Last flash information, steering control configuration, vehicle information.
WEBLINK		Software to program module.

TROUBLESHOOTING TABLE

PROBLEM	SOLUTION
Gauges do not work, radio shows OBD2 Error 1 or Error 2.	If anything is connected to the OBD2 or CAN wires of vehicle (programmer, throttle controller, insurance tracker, etc.) try unplugging it to see if gauges work. If gauges work without it installed, call tech support for options. Reset the RR.
CX-5 and Mazda3 No audio after installing new radio. Factory radio no longer has sound.	Check 7.5 amp "AUDIO 2" fuse located under the hood.
The light on the Maestro is flashing RED ONCE .	There is no firmware on the module. Flash the RR module using Weblink Desktop and log in. Do NOT use DEMO MODE.
The light on the Maestro is blinking RED TWICE and the radio IS turning on.	Ensure the 4-pin data cable is connected between the radio and the RR, and that it is plugged into the black port on the Maestro RR. The red and blue ports on the RR should be empty. Make sure the correct radio model and serial number were entered during the flash. Verify the radio's serial number entered during the flash matches what is listed on the radio screen. This can be found in the settings of the radio, listed as Device Id, Device Number, or Serial Number.
The light on the Maestro is blinking RED TWICE but the radio is NOT turning on.	If installing a modular radio and it is not turning on, ensure the screen is secured and any trim pieces on the radio have been installed fully. Not installing these fully will prevent radio from powering up and show a 2x red error as well. Test red and yellow wires for DC voltage at radio using a multimeter. Contact support if no voltage on red or yellow.

MAESTRO RR RESET PROCEDURE:

Turn the key to the OFF position, then disconnect all connectors from the module.

Press and hold the module's programming button and connect all the connectors back to the module. Wait, the module's LED will flash RED rapidly (this may take up to 10 seconds).

Release the programming button. Wait, the LED will turn solid GREEN for 2 seconds to show the reset was successful.

TECHNICAL ASSISTANCE

Phone: 1-866-427-2999

Email: maestro.support@idatalink.com

Web: maestro.idatalink.com/support add www.12voldata.com/forum/

IMPORTANT: To ensure proper operation, the aftermarket radio needs to have the latest firmware from the manufacturer. Please visit the radio manufacturer's website and look for any updates pertaining to your radio.

2021

MAZDA CX-3

TOUCHSCREEN WITHOUT AMPLIFIER

RETAINS STEERING WHEEL CONTROLS, VEHICLE SETTINGS, AND MORE!



PRODUCTS REQUIRED

iDatalink Maestro RR or RR2 Radio Replacement Interface
iDatalink Maestro HRR-MA2 Installation Harness

PROGRAMMED FIRMWARE

ADS-RR(SR)-MA1-DS

ADDITIONAL RESOURCES

[Maestro RR2 Programmable Outputs Guide](#)

OPTIONAL ACCESSORIES

K40[™]
ELECTRONICS
ESCORT

Click here for:
[Radar Installation Guides](#)

ANTENNA ADAPTER (MAY BE REQUIRED)

HEAD UNIT ADAPTER:
ACC-HU-PI01, SON1, KEN1, KEN2, ALP1

WELCOME

Congratulations on the purchase of your iDatalink Maestro RR Radio replacement solution. You are now a few simple steps away from enjoying your new car radio with enhanced features.

Before starting your installation, please ensure that your iDatalink Maestro module is programmed with the correct firmware for your vehicle and that you carefully review the install guide.

Please note that Maestro RR will only retain functionalities that were originally available in the vehicle.

NEED HELP?

 1 866 427-2999

 maestro.support@idatalink.com

 maestro.idatalink.com/support
www.12voldata.com/forum

TABLE OF CONTENTS

Installation Instructions	3
Wiring Diagram	4
Radio Wire Reference Chart	5
Module Diagnostics	6
Troubleshooting Table	7

INSTALLATION INSTRUCTIONS P1/1

STEP 1

- **Disconnect the negative battery terminal** (not doing so may blow the 7.5A audio fuse 2 under hood during the installation of the radio).
- Remove the factory radio
If using head unit adapter (sold separately), connect HRR-MA2 harness to adapter and skip to step 2.
- Unbox the aftermarket radio and locate its main harness.
- Cut and remove the black 20 pin connector from the HRR-MA2 T-harness and connect the wires, shown in the wiring diagram, from aftermarket radio main harness to the HRR-MA2 T-harness and match the wire functions.
Note: only connect purple/white wire to radio reverse input or module damage will occur.

STEP 2

- Plug in the extension harness to HRR-MA2 main harness 8-pin black connector.
- Route the extension harness to the radio tuner in the passenger kick panel.

STEP 3

- Connect both the 18-pin and 28-pin connectors of HRR-MA2 T-harness to the factory radio harness (at CMU, behind/below display).

STEP 4

- Connect the 20-pin adapter (white connector) to the factory radio tuner in the passenger kick panel.
- Connect the adapter's 8-pin black connector to the extension harness.
- Plug the blue POWER ANT terminal to amplified antenna adapter (if required).

STEP 5

- Plug the harnesses into the aftermarket radio.
- Connect the backup cam cable into the aftermarket radio (if equipped).
- Plug the antenna adapter (if required).
- Plug the Data cable to the data port of the aftermarket radio.

Note: On Pioneer radio, ensure that there is nothing plugged into the W/R port.

STEP 6

- Connect all the harnesses to the Maestro RR module.
- **Reconnect the negative battery terminal then test your installation.**

WIRING DIAGRAM

STEP 1

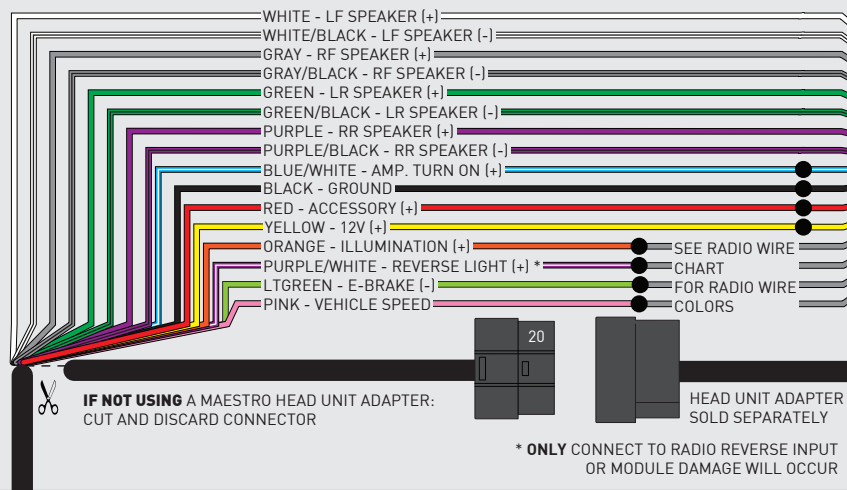

STEP 5

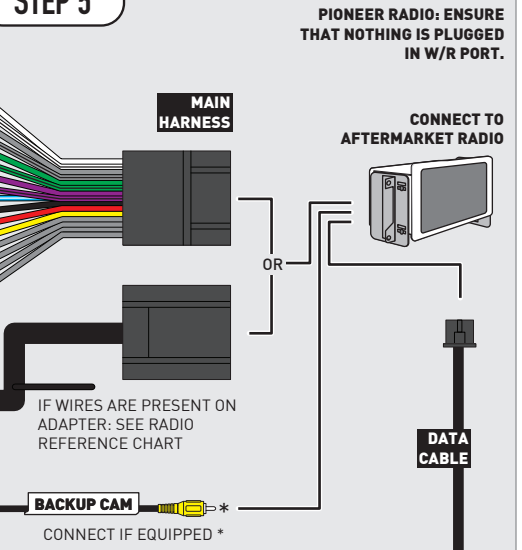

STEP 2

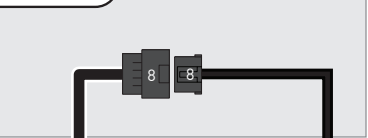

STEP 3

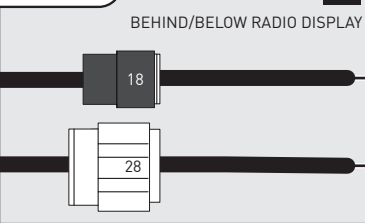

STEP 4

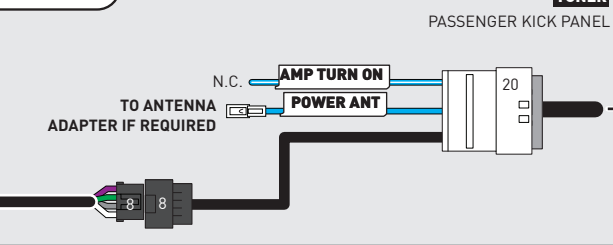

STEP 6

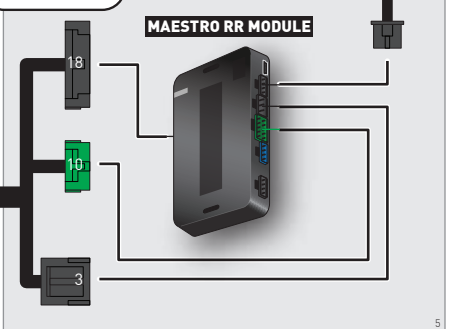

NOT REQUIRED

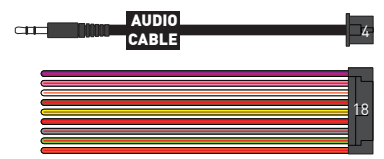
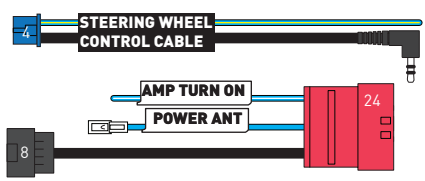
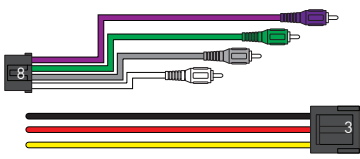

RADIO WIRE REFERENCE CHART

MA2 T-harness Wire Description	Polarity	Wire Color on Maestro T-Harness	Wire Color on Alpine cable	Wire Color on Kenwood cable	Wire Color on Pioneer cable	Wire Color on Sony cable
Illumination	(+)	Orange	N/A	Orange/White	Orange/White	Orange
Reverse Light*	(+)	Purple/White	Orange/White	Purple/White	Purple/White	Purple/White
E-Brake	(-)	Lt Green	Yellow/Blue	Lt Green	Lt Green	Lt Green
VSS (vehicle speed sensor)	(DATA)	Pink	Green/White	Pink	Pink	N/A

Head unit adapter wiring (optional accessory, sold separately)

ACC-HU-ALP1 Wire Description	Polarity	Wire Color on Adapter	Alpine Radio
VSS (vehicle speed sensor)	(DATA)	Green/White	Green/White

ACC-HU-KEN1 Wire Description	Polarity	Wire Color on Adapter	Kenwood Radio
CAM	(+)	Green/Red	Refer to camera/radio manual
CAM	(-)	Green/White	Refer to camera/radio manual
Steering Wheel Controls	(DATA)	Blue/Yellow	n/a

ACC-HU-KEN2 Wire Description	Polarity	Wire Color on Adapter	Kenwood Radio
E-Brake	(-)	LtGreen	LtGreen
Reverse Light*	(+)	Purple/White	Purple/White
Steering Wheel Controls	(DATA)	Blue/Yellow	n/a

* Reverse light wire: Only connect to radio or module damage will occur.

MODULE DIAGNOSTICS



LED 1 Module/Firmware status	LED 2 (RR2) Bluetooth activity	LED STATUS	DIAGNOSTIC
● or ●		RED or GREEN flashing	LED flashes 1 or more times, either red or green, when a steering wheel button is pressed : normal operation.
●		1 RED flash	Module has no firmware. Flash module using Weblink Desktop and log in. Do <u>NOT</u> use DEMO MODE.
●		2 RED flashes	Problem detected. Consult troubleshooting table.
●		1 GREEN flash	After radio boots up : Normal operation.
	●	3 GREEN flashes	Bluetooth is activated. Turns off after one minute: Normal operation.
●	●	OFF	Normal operation (inactive).

VIDEO HELP		Installation, product information, vehicle specific videos.
VERIFY FLASH		Last flash information, steering control configuration, vehicle information.
WEBLINK		Software to program module.

TROUBLESHOOTING TABLE

PROBLEM	SOLUTION
Gauges do not work, radio shows OBD2 Error 1 or Error 2.	If anything is connected to the OBD2 or CAN wires of vehicle (programmer, throttle controller, insurance tracker, etc.) try unplugging it to see if gauges work. If gauges work without it installed, call tech support for options. Reset the RR.
CX-5 and Mazda3 No audio after installing new radio. Factory radio no longer has sound.	Check 7.5 amp "AUDIO 2" fuse located under the hood.
The light on the Maestro is flashing RED ONCE .	There is no firmware on the module. Flash the RR module using Weblink Desktop and log in. Do NOT use DEMO MODE.
The light on the Maestro is blinking RED TWICE and the radio IS turning on.	Ensure the 4-pin data cable is connected between the radio and the RR, and that it is plugged into the black port on the Maestro RR. The red and blue ports on the RR should be empty. Make sure the correct radio model and serial number were entered during the flash. Verify the radio's serial number entered during the flash matches what is listed on the radio screen. This can be found in the settings of the radio, listed as Device Id, Device Number, or Serial Number.
The light on the Maestro is blinking RED TWICE but the radio is NOT turning on.	If installing a modular radio and it is not turning on, ensure the screen is secured and any trim pieces on the radio have been installed fully. Not installing these fully will prevent radio from powering up and show a 2x red error as well. Test red and yellow wires for DC voltage at radio using a multimeter. Contact support if no voltage on red or yellow.

MAESTRO RR RESET PROCEDURE:

Turn the key to the OFF position, then disconnect all connectors from the module.

Press and hold the module's programming button and connect all the connectors back to the module. Wait, the module's LED will flash RED rapidly (this may take up to 10 seconds).

Release the programming button. Wait, the LED will turn solid GREEN for 2 seconds to show the reset was successful.

TECHNICAL ASSISTANCE

Phone: 1-866-427-2999

Email: maestro.support@idatalink.com

Web: maestro.idatalink.com/support add www.12voldata.com/forum/

IMPORTANT: To ensure proper operation, the aftermarket radio needs to have the latest firmware from the manufacturer. Please visit the radio manufacturer's website and look for any updates pertaining to your radio.

2016-2018
MAZDA CX-5
TOUCHSCREEN

RETAINS STEERING WHEEL CONTROLS, VEHICLE SETTINGS, AND MORE!



PRODUCTS REQUIRED

iDatalink Maestro RR or RR2 Radio Replacement Interface
iDatalink Maestro HRR-MA2 Installation Harness

PROGRAMMED FIRMWARE

ADS-RR(SR)-MA1-DS

ADDITIONAL RESOURCES

[Maestro RR2 Programmable Outputs Guide](#)

OPTIONAL ACCESSORIES

K40
ELECTRONICS
ESCORT

Click here for:
[Radar Installation Guides](#)

ANTENNA ADAPTER (MAY BE REQUIRED)

HEAD UNIT ADAPTER:
ACC-HU-PI01, SON1, KEN1, KEN2, ALP1

WELCOME

Congratulations on the purchase of your iDatalink Maestro RR Radio replacement solution. You are now a few simple steps away from enjoying your new car radio with enhanced features.

Before starting your installation, please ensure that your iDatalink Maestro module is programmed with the correct firmware for your vehicle and that you carefully review the install guide.

Please note that Maestro RR will only retain functionalities that were originally available in the vehicle.

NEED HELP?

 1 866 427-2999

 maestro.support@idatalink.com

 maestro.idatalink.com/support
www.12voldata.com/forum

TABLE OF CONTENTS

Installation Instructions	3
Wiring Diagram	4
Radio Wire Reference Chart	5
Module Diagnostics	6
Troubleshooting Table	7

INSTALLATION INSTRUCTIONS P1/1

STEP 1

- **Disconnect the negative battery terminal** (not doing so may blow the 7.5A audio fuse 2 under hood during the installation of the radio).
- Remove the factory radio

If using head unit adapter (sold separately), connect HRR-MA2 harness to adapter and skip to step 2.

- Unbox the aftermarket radio and locate its main harness.
- Cut and remove the black 20 pin connector from the HRR-MA2 T-harness and connect the wires, shown in the wiring diagram, from aftermarket radio main harness to the HRR-MA2 T-harness and match the wire functions.

Note: only connect purple/white wire to radio reverse input or module damage will occur.

STEP 2

If the vehicle DOES NOT have a factory amplifier:

- Plug in the extension harness to HRR-MA2 main harness 8-pin black connector.

If the vehicle DOES have a factory amplifier:

- Plug in the extension harness to 8-pin black connector of RCA cable.
- Connect the RCAs to the radio outputs: white/left front, gray/right front, green/left rear, purple/right rear.
- Route the extension harness to the radio tuner in the passenger kick panel.

STEP 3

- Connect both the 18-pin and 28-pin connectors of HRR-MA2 T-harness to the factory radio harness (at CMU, behind/below display).

STEP 4

- Connect the 24-pin adapter (red connector) to the factory radio tuner in the passenger kick panel.
- Connect the adapter's 8-pin black connector to the extension harness.
- Plug the blue POWER ANT terminal to amplified antenna adapter (if required).

STEP 5

- Plug the harnesses into the aftermarket radio.
- Connect the backup cam cable into the aftermarket radio (if equipped).
- Plug the antenna adapter (if required).
- Plug the Data cable to the data port of the aftermarket radio.

Note: On Pioneer radio, ensure that there is nothing plugged into the W/R port.

STEP 6

- Connect all the harnesses to the Maestro RR module.
- **Reconnect the negative battery terminal then test your installation.**

WIRING DIAGRAM

STEP 1

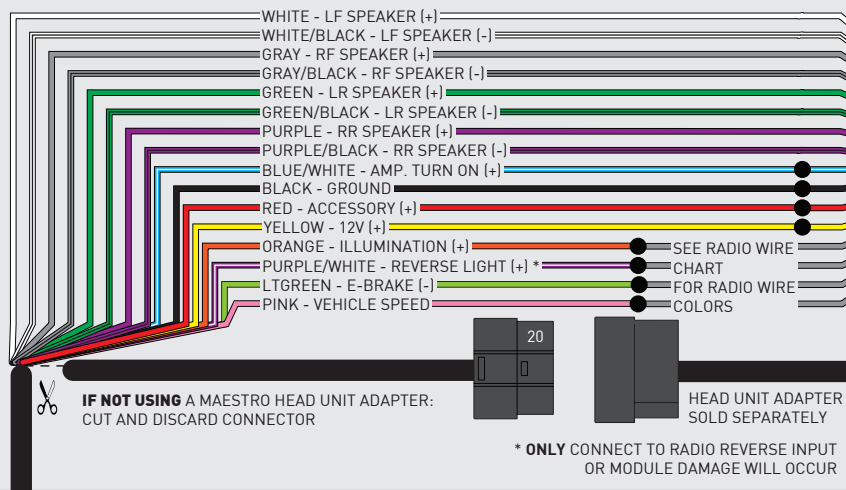

STEP 5

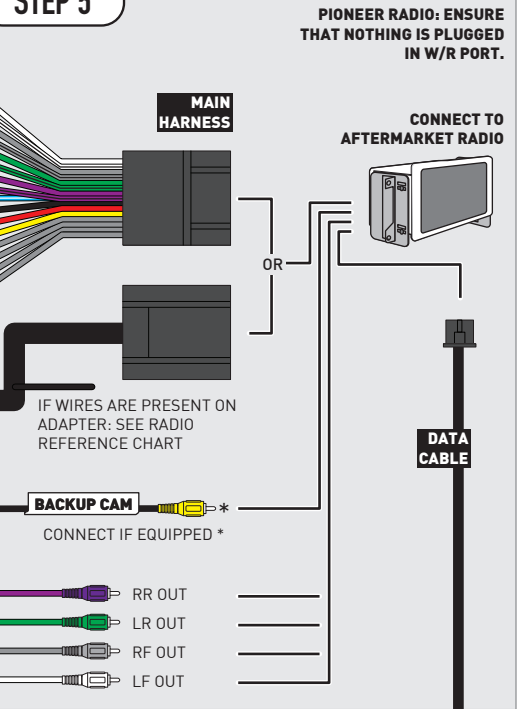

STEP 2

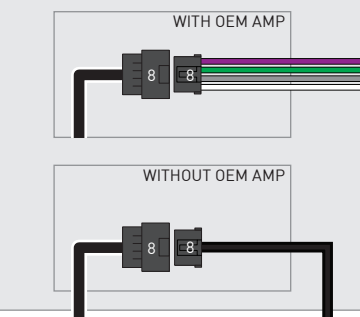

STEP 3

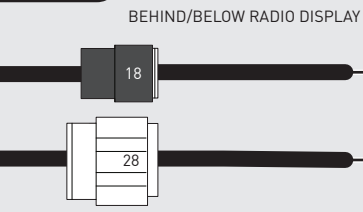

STEP 4

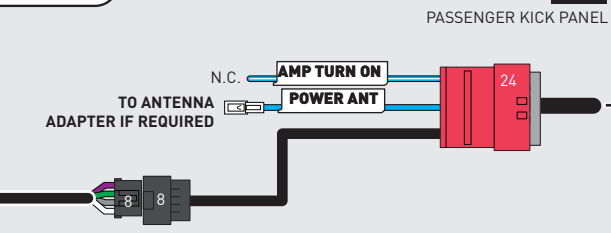

STEP 6

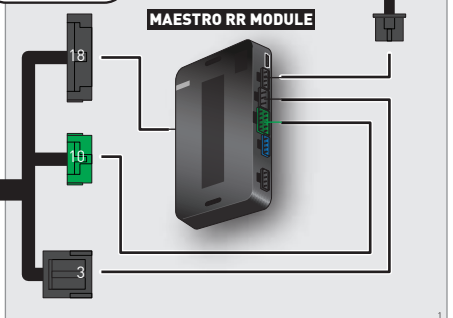

NOT REQUIRED

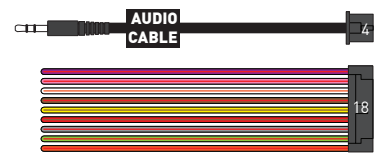
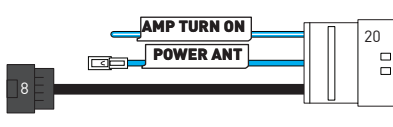
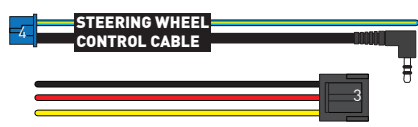

RADIO WIRE REFERENCE CHART

MA2 T-harness Wire Description	Polarity	Wire Color on Maestro T-Harness	Wire Color on Alpine cable	Wire Color on Kenwood cable	Wire Color on Pioneer cable	Wire Color on Sony cable
Illumination	(+)	Orange	N/A	Orange/White	Orange/White	Orange
Reverse Light*	(+)	Purple/White	Orange/White	Purple/White	Purple/White	Purple/White
E-Brake	(-)	Lt Green	Yellow/Blue	Lt Green	Lt Green	Lt Green
VSS (vehicle speed sensor)	(DATA)	Pink	Green/White	Pink	Pink	N/A

Head unit adapter wiring (optional accessory, sold separately)

ACC-HU-ALP1 Wire Description	Polarity	Wire Color on Adapter	Alpine Radio
VSS (vehicle speed sensor)	(DATA)	Green/White	Green/White

ACC-HU-KEN1 Wire Description	Polarity	Wire Color on Adapter	Kenwood Radio
CAM	(+)	Green/Red	Refer to camera/radio manual
CAM	(-)	Green/White	Refer to camera/radio manual
Steering Wheel Controls	(DATA)	Blue/Yellow	n/a

ACC-HU-KEN2 Wire Description	Polarity	Wire Color on Adapter	Kenwood Radio
E-Brake	(-)	LtGreen	LtGreen
Reverse Light*	(+)	Purple/White	Purple/White
Steering Wheel Controls	(DATA)	Blue/Yellow	n/a

* Reverse light wire: Only connect to radio or module damage will occur.

MODULE DIAGNOSTICS



LED 1 Module/Firmware status	LED 2 (RR2) Bluetooth activity	LED STATUS	DIAGNOSTIC
● or ●		RED or GREEN flashing	LED flashes 1 or more times, either red or green, when a steering wheel button is pressed : normal operation.
●		1 RED flash	Module has no firmware. Flash module using Weblink Desktop and log in. Do <u>NOT</u> use DEMO MODE.
●		2 RED flashes	Problem detected. Consult troubleshooting table.
●		1 GREEN flash	After radio boots up : Normal operation.
	●	3 GREEN flashes	Bluetooth is activated. Turns off after one minute: Normal operation.
●	●	OFF	Normal operation (inactive).

VIDEO HELP		Installation, product information, vehicle specific videos.
VERIFY FLASH		Last flash information, steering control configuration, vehicle information.
WEBLINK		Software to program module.

TROUBLESHOOTING TABLE

PROBLEM	SOLUTION
Gauges do not work, radio shows OBD2 Error 1 or Error 2.	If anything is connected to the OBD2 or CAN wires of vehicle (programmer, throttle controller, insurance tracker, etc.) try unplugging it to see if gauges work. If gauges work without it installed, call tech support for options. Reset the RR.
CX-5 and Mazda3 No audio after installing new radio. Factory radio no longer has sound.	Check 7.5 amp "AUDIO 2" fuse located under the hood.
The light on the Maestro is flashing RED ONCE .	There is no firmware on the module. Flash the RR module using Weblink Desktop and log in. Do NOT use DEMO MODE.
The light on the Maestro is blinking RED TWICE and the radio IS turning on.	Ensure the 4-pin data cable is connected between the radio and the RR, and that it is plugged into the black port on the Maestro RR. The red and blue ports on the RR should be empty. Make sure the correct radio model and serial number were entered during the flash. Verify the radio's serial number entered during the flash matches what is listed on the radio screen. This can be found in the settings of the radio, listed as Device Id, Device Number, or Serial Number.
The light on the Maestro is blinking RED TWICE but the radio is NOT turning on.	If installing a modular radio and it is not turning on, ensure the screen is secured and any trim pieces on the radio have been installed fully. Not installing these fully will prevent radio from powering up and show a 2x red error as well. Test red and yellow wires for DC voltage at radio using a multimeter. Contact support if no voltage on red or yellow.

MAESTRO RR RESET PROCEDURE:

Turn the key to the OFF position, then disconnect all connectors from the module.

Press and hold the module's programming button and connect all the connectors back to the module. Wait, the module's LED will flash RED rapidly (this may take up to 10 seconds).

Release the programming button. Wait, the LED will turn solid GREEN for 2 seconds to show the reset was successful.

TECHNICAL ASSISTANCE

Phone: 1-866-427-2999

Email: maestro.support@idatalink.com

Web: maestro.idatalink.com/support add www.12voldata.com/forum/

IMPORTANT: To ensure proper operation, the aftermarket radio needs to have the latest firmware from the manufacturer. Please visit the radio manufacturer's website and look for any updates pertaining to your radio.

RETAINS STEERING WHEEL CONTROLS, VEHICLE SETTINGS, AND MORE!



PRODUCTS REQUIRED

iDatalink Maestro RR or RR2 Radio Replacement Interface
iDatalink Maestro HRR-MA2 Installation Harness

PROGRAMMED FIRMWARE

ADS-RR(SR)-MA1-DS

ADDITIONAL RESOURCES

[Maestro RR2 Programmable Outputs Guide](#)

OPTIONAL ACCESSORIES

K40
ELECTRONICS
ESCORT

Click here for:
[Radar Installation Guides](#)

ANTENNA ADAPTER (MAY BE REQUIRED)

HEAD UNIT ADAPTER:
ACC-HU-PI01, SON1, KEN1, KEN2, ALP1

WELCOME

Congratulations on the purchase of your iDatalink Maestro RR Radio replacement solution. You are now a few simple steps away from enjoying your new car radio with enhanced features.

Before starting your installation, please ensure that your iDatalink Maestro module is programmed with the correct firmware for your vehicle and that you carefully review the install guide.

Please note that Maestro RR will only retain functionalities that were originally available in the vehicle.

NEED HELP?

 1 866 427-2999

 maestro.support@idatalink.com

 maestro.idatalink.com/support
www.12voltdata.com/forum

TABLE OF CONTENTS

Installation Instructions	3
Wiring Diagram	4
Radio Wire Reference Chart	5
Module Diagnostics	6
Troubleshooting Table	7

INSTALLATION INSTRUCTIONS P1/1

STEP 1

- **Disconnect the negative battery terminal** (not doing so may blow the 7.5A audio fuse 2 under hood during the installation of the radio).
- Remove the factory radio

If using head unit adapter (sold separately), connect HRR-MA2 harness to adapter and skip to step 2.

- Unbox the aftermarket radio and locate its main harness.
- Cut and remove the black 20 pin connector from the HRR-MA2 T-harness and connect the wires, shown in the wiring diagram, from aftermarket radio main harness to the HRR-MA2 T-harness and match the wire functions.

Note: only connect purple/white wire to radio reverse input or module damage will occur.

STEP 2

If the vehicle DOES NOT have a factory amplifier:

- Plug in the extension harness to HRR-MA2 main harness 8-pin black connector.

If the vehicle DOES have a factory amplifier:

- Plug in the extension harness to 8-pin black connector of RCA cable.
- Connect the RCAs to the radio outputs: white/left front, gray/right front, green/left rear, purple/right rear.
- Route the extension harness to the radio tuner in the passenger kick panel.

STEP 3

- Connect both the 18-pin and 28-pin connectors of HRR-MA2 T-harness to the factory radio harness (at CMU, behind/below display).

STEP 4

- Connect the 20-pin adapter (white connector) to the factory radio tuner in the passenger kick panel.
- Connect the adapter's 8-pin black connector to the extension harness.
- Plug the blue POWER ANT terminal to amplified antenna adapter (if required).

STEP 5

- Plug the harnesses into the aftermarket radio.
- Connect the backup cam cable into the aftermarket radio (if equipped).
- Plug the antenna adapter (if required).
- Plug the Data cable to the data port of the aftermarket radio.

Note: On Pioneer radio, ensure that there is nothing plugged into the W/R port.

STEP 6

- Connect all the harnesses to the Maestro RR module.
- **Reconnect the negative battery terminal then test your installation.**

WIRING DIAGRAM

STEP 1

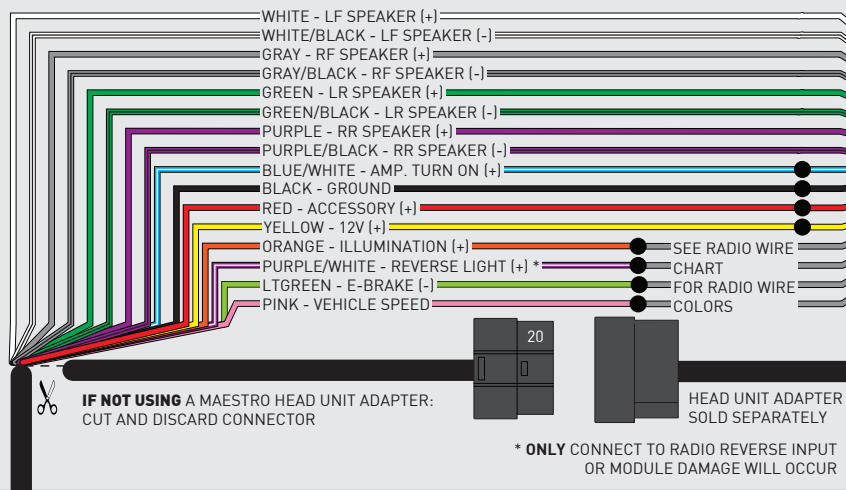

STEP 5

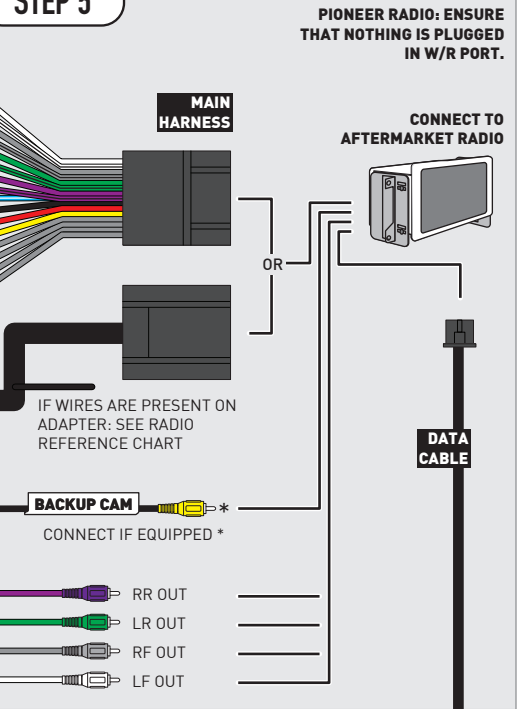

STEP 2

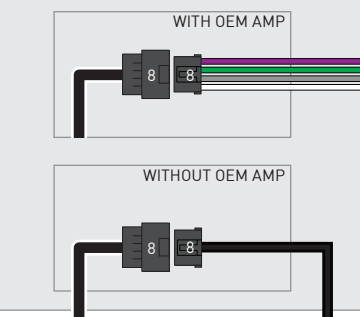

STEP 3

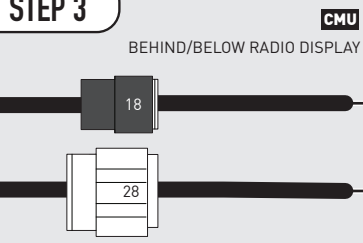

STEP 4

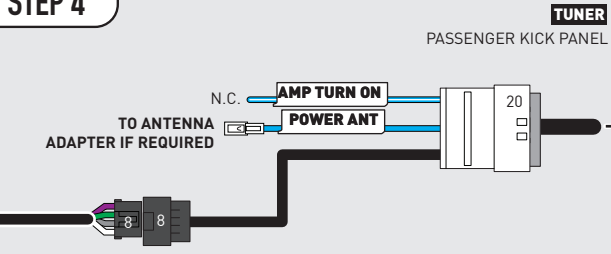

STEP 6

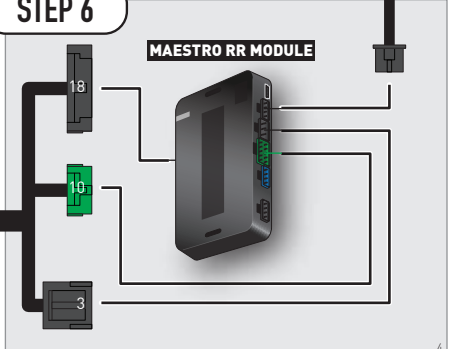

NOT REQUIRED

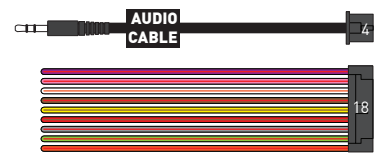
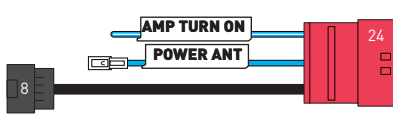
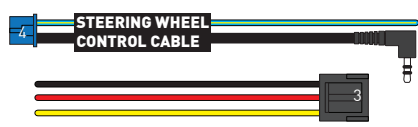

RADIO WIRE REFERENCE CHART

MA2 T-harness Wire Description	Polarity	Wire Color on Maestro T-Harness	Wire Color on Alpine cable	Wire Color on Kenwood cable	Wire Color on Pioneer cable	Wire Color on Sony cable
Illumination	(+)	Orange	N/A	Orange/White	Orange/White	Orange
Reverse Light*	(+)	Purple/White	Orange/White	Purple/White	Purple/White	Purple/White
E-Brake	(-)	Lt Green	Yellow/Blue	Lt Green	Lt Green	Lt Green
VSS (vehicle speed sensor)	(DATA)	Pink	Green/White	Pink	Pink	N/A

Head unit adapter wiring (optional accessory, sold separately)

ACC-HU-ALP1 Wire Description	Polarity	Wire Color on Adapter	Alpine Radio
VSS (vehicle speed sensor)	(DATA)	Green/White	Green/White

ACC-HU-KEN1 Wire Description	Polarity	Wire Color on Adapter	Kenwood Radio
CAM	(+)	Green/Red	Refer to camera/radio manual
CAM	(-)	Green/White	Refer to camera/radio manual
Steering Wheel Controls	(DATA)	Blue/Yellow	n/a

ACC-HU-KEN2 Wire Description	Polarity	Wire Color on Adapter	Kenwood Radio
E-Brake	(-)	LtGreen	LtGreen
Reverse Light*	(+)	Purple/White	Purple/White
Steering Wheel Controls	(DATA)	Blue/Yellow	n/a

* Reverse light wire: Only connect to radio or module damage will occur.

MODULE DIAGNOSTICS



LED 1 Module/Firmware status	LED 2 (RR2) Bluetooth activity	LED STATUS	DIAGNOSTIC
● or ●		RED or GREEN flashing	LED flashes 1 or more times, either red or green, when a steering wheel button is pressed : normal operation.
●		1 RED flash	Module has no firmware. Flash module using Weblink Desktop and log in. Do <u>NOT</u> use DEMO MODE.
●		2 RED flashes	Problem detected. Consult troubleshooting table.
●		1 GREEN flash	After radio boots up : Normal operation.
	●	3 GREEN flashes	Bluetooth is activated. Turns off after one minute: Normal operation.
●	●	OFF	Normal operation (inactive).

VIDEO HELP		Installation, product information, vehicle specific videos.
VERIFY FLASH		Last flash information, steering control configuration, vehicle information.
WEBLINK		Software to program module.

TROUBLESHOOTING TABLE

PROBLEM	SOLUTION
Gauges do not work, radio shows OBD2 Error 1 or Error 2.	If anything is connected to the OBD2 or CAN wires of vehicle (programmer, throttle controller, insurance tracker, etc.) try unplugging it to see if gauges work. If gauges work without it installed, call tech support for options. Reset the RR.
CX-5 and Mazda3 No audio after installing new radio. Factory radio no longer has sound.	Check 7.5 amp "AUDIO 2" fuse located under the hood.
The light on the Maestro is flashing RED ONCE .	There is no firmware on the module. Flash the RR module using Weblink Desktop and log in. Do NOT use DEMO MODE.
The light on the Maestro is blinking RED TWICE and the radio IS turning on.	Ensure the 4-pin data cable is connected between the radio and the RR, and that it is plugged into the black port on the Maestro RR. The red and blue ports on the RR should be empty. Make sure the correct radio model and serial number were entered during the flash. Verify the radio's serial number entered during the flash matches what is listed on the radio screen. This can be found in the settings of the radio, listed as Device Id, Device Number, or Serial Number.
The light on the Maestro is blinking RED TWICE but the radio is NOT turning on.	If installing a modular radio and it is not turning on, ensure the screen is secured and any trim pieces on the radio have been installed fully. Not installing these fully will prevent radio from powering up and show a 2x red error as well. Test red and yellow wires for DC voltage at radio using a multimeter. Contact support if no voltage on red or yellow.

MAESTRO RR RESET PROCEDURE:

Turn the key to the OFF position, then disconnect all connectors from the module.

Press and hold the module's programming button and connect all the connectors back to the module. Wait, the module's LED will flash RED rapidly (this may take up to 10 seconds).

Release the programming button. Wait, the LED will turn solid GREEN for 2 seconds to show the reset was successful.

TECHNICAL ASSISTANCE

Phone: 1-866-427-2999

Email: maestro.support@idatalink.com

Web: maestro.idatalink.com/support add www.12voldata.com/forum/

IMPORTANT: To ensure proper operation, the aftermarket radio needs to have the latest firmware from the manufacturer. Please visit the radio manufacturer's website and look for any updates pertaining to your radio.

RETAINS STEERING WHEEL CONTROLS, VEHICLE SETTINGS, AND MORE!



PRODUCTS REQUIRED

iDataLink Maestro RR or RR2 Radio Replacement Interface
iDataLink Maestro HRR-MA2 Installation Harness

PROGRAMMED FIRMWARE

ADS-RR(SR)-MA1-DS

ADDITIONAL RESOURCES

[Maestro RR2 Programmable Outputs Guide](#)

OPTIONAL ACCESSORIES

K40[™]
ELECTRONICS
ESCORT

Click here for:
[Radar Installation Guides](#)

ANTENNA ADAPTER (MAY BE REQUIRED)

HEAD UNIT ADAPTER:
ACC-HU-PI01, SON1, KEN1, KEN2, ALP1

WELCOME

Congratulations on the purchase of your iDatalink Maestro RR Radio replacement solution. You are now a few simple steps away from enjoying your new car radio with enhanced features.

Before starting your installation, please ensure that your iDatalink Maestro module is programmed with the correct firmware for your vehicle and that you carefully review the install guide.

Please note that Maestro RR will only retain functionalities that were originally available in the vehicle.

NEED HELP?

 1 866 427-2999

 maestro.support@idatalink.com

 maestro.idatalink.com/support
www.12voldata.com/forum

TABLE OF CONTENTS

Installation Instructions	3
Wiring Diagram	4
Radio Wire Reference Chart	5
Module Diagnostics	6
Troubleshooting Table	7

INSTALLATION INSTRUCTIONS P1/1

STEP 1

- **Disconnect the negative battery terminal** (not doing so may blow the 7.5A audio fuse 2 under hood during the installation of the radio).
- Remove the factory radio

If using head unit adapter (sold separately), connect HRR-MA2 harness to adapter and skip to step 2.

- Unbox the aftermarket radio and locate its main harness.
- Cut and remove the black 20 pin connector from the HRR-MA2 T-harness and connect the wires, shown in the wiring diagram, from aftermarket radio main harness to the HRR-MA2 T-harness and match the wire functions.

Note: only connect purple/white wire to radio reverse input or module damage will occur.

STEP 2

If the vehicle DOES NOT have a factory amplifier:

- Plug in the extension harness to HRR-MA2 main harness 8-pin black connector.

If the vehicle DOES have a factory amplifier:

- Plug in the extension harness to 8-pin black connector of RCA cable.
- Connect the RCAs to the radio outputs: white/left front, gray/right front, green/left rear, purple/right rear.
- Route the extension harness to the radio tuner in the passenger kick panel.

STEP 3

- Connect both the 18-pin and 28-pin connectors of HRR-MA2 T-harness to the factory radio harness (at CMU, behind/below display).

STEP 4

- Connect the 20-pin adapter (white connector) or the 24-pin adapter (red connector) to the factory radio tuner in the passenger kick panel.
- Connect the adapter's 8-pin black connector to the extension harness.
- Plug the blue POWER ANT terminal to amplified antenna adapter (if required).

STEP 5

- Plug the harnesses into the aftermarket radio.
- Connect the backup cam cable into the aftermarket radio (if equipped).
- Plug the antenna adapter (if required).
- Plug the Data cable to the data port of the aftermarket radio.

Note: On Pioneer radio, ensure that there is nothing plugged into the W/R port.

STEP 6

- Connect all the harnesses to the Maestro RR module.
- **Reconnect the negative battery terminal then test your installation.**

WIRING DIAGRAM

STEP 1

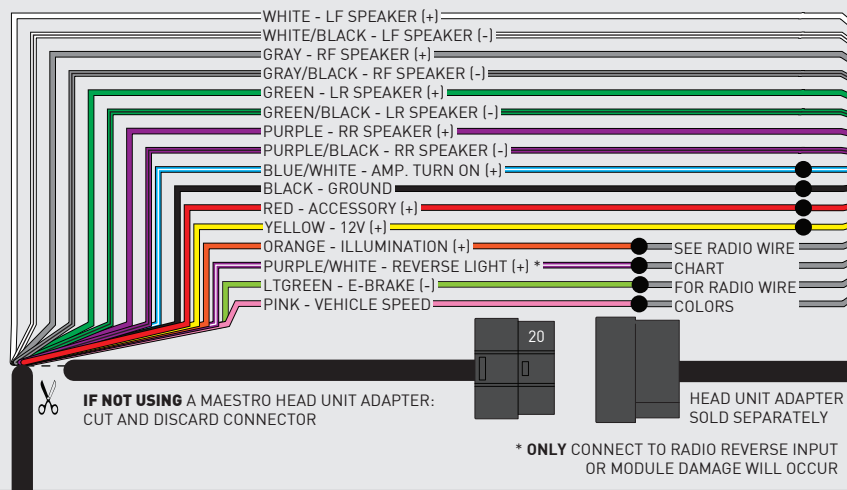

STEP 5

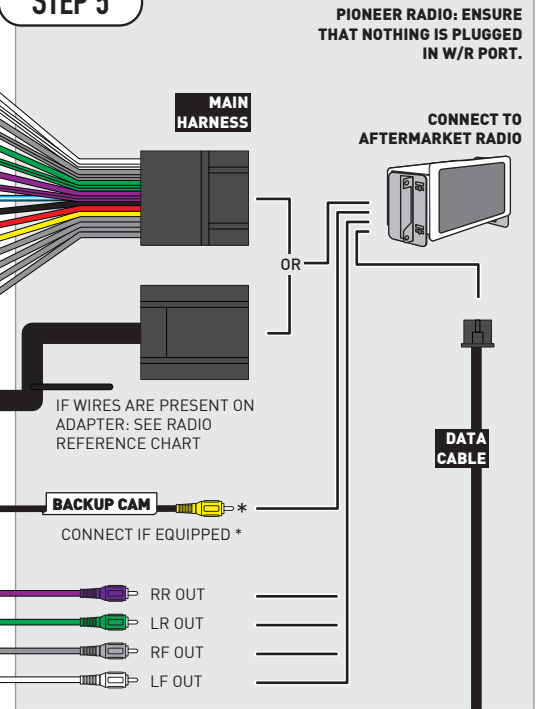

STEP 2

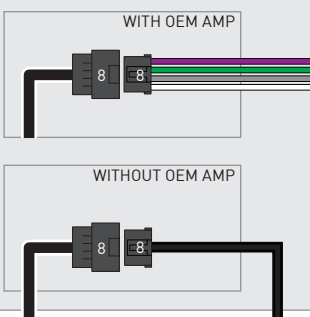

STEP 3

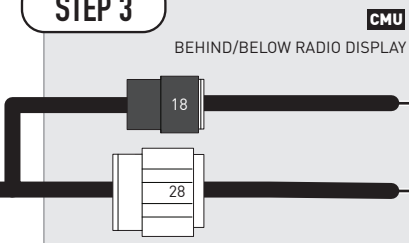

STEP 4

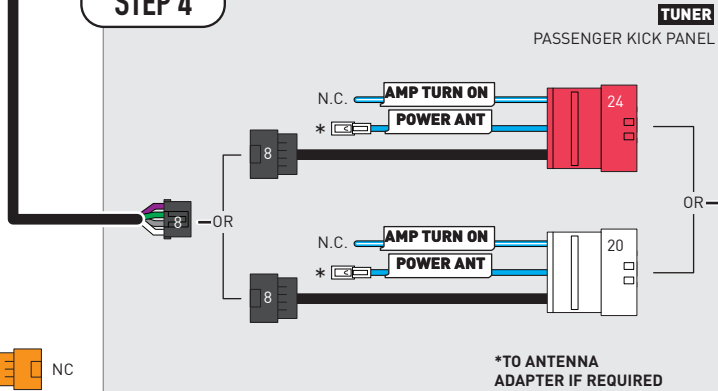

STEP 6

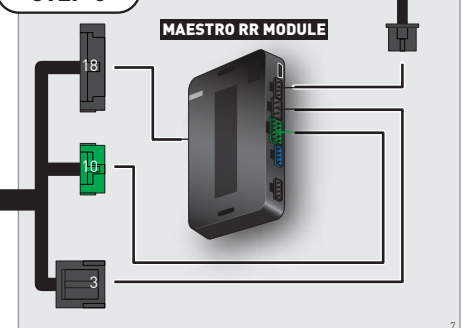

NOT REQUIRED



RADIO WIRE REFERENCE CHART

MA2 T-harness Wire Description	Polarity	Wire Color on Maestro T-Harness	Wire Color on Alpine cable	Wire Color on Kenwood cable	Wire Color on Pioneer cable	Wire Color on Sony cable
Illumination	(+)	Orange	N/A	Orange/White	Orange/White	Orange
Reverse Light*	(+)	Purple/White	Orange/White	Purple/White	Purple/White	Purple/White
E-Brake	(-)	Lt Green	Yellow/Blue	Lt Green	Lt Green	Lt Green
VSS (vehicle speed sensor)	(DATA)	Pink	Green/White	Pink	Pink	N/A

Head unit adapter wiring (optional accessory, sold separately)

ACC-HU-ALP1 Wire Description	Polarity	Wire Color on Adapter	Alpine Radio
VSS (vehicle speed sensor)	(DATA)	Green/White	Green/White

ACC-HU-KEN1 Wire Description	Polarity	Wire Color on Adapter	Kenwood Radio
CAM	(+)	Green/Red	Refer to camera/radio manual
CAM	(-)	Green/White	Refer to camera/radio manual
Steering Wheel Controls	(DATA)	Blue/Yellow	n/a

ACC-HU-KEN2 Wire Description	Polarity	Wire Color on Adapter	Kenwood Radio
E-Brake	(-)	LtGreen	LtGreen
Reverse Light*	(+)	Purple/White	Purple/White
Steering Wheel Controls	(DATA)	Blue/Yellow	n/a

* Reverse light wire: Only connect to radio or module damage will occur.

MODULE DIAGNOSTICS



LED 1 Module/Firmware status	LED 2 (RR2) Bluetooth activity	LED STATUS	DIAGNOSTIC
● or ●		RED or GREEN flashing	LED flashes 1 or more times, either red or green, when a steering wheel button is pressed : normal operation.
●		1 RED flash	Module has no firmware. Flash module using Weblink Desktop and log in. Do <u>NOT</u> use DEMO MODE.
●		2 RED flashes	Problem detected. Consult troubleshooting table.
●		1 GREEN flash	After radio boots up : Normal operation.
	●	3 GREEN flashes	Bluetooth is activated. Turns off after one minute: Normal operation.
●	●	OFF	Normal operation (inactive).

VIDEO HELP		Installation, product information, vehicle specific videos.
VERIFY FLASH		Last flash information, steering control configuration, vehicle information.
WEBLINK		Software to program module.

TROUBLESHOOTING TABLE

PROBLEM	SOLUTION
Gauges do not work, radio shows OBD2 Error 1 or Error 2.	If anything is connected to the OBD2 or CAN wires of vehicle (programmer, throttle controller, insurance tracker, etc.) try unplugging it to see if gauges work. If gauges work without it installed, call tech support for options. Reset the RR.
CX-5 and Mazda3 No audio after installing new radio. Factory radio no longer has sound.	Check 7.5 amp "AUDIO 2" fuse located under the hood.
The light on the Maestro is flashing RED ONCE .	There is no firmware on the module. Flash the RR module using Weblink Desktop and log in. Do NOT use DEMO MODE.
The light on the Maestro is blinking RED TWICE and the radio IS turning on.	Ensure the 4-pin data cable is connected between the radio and the RR, and that it is plugged into the black port on the Maestro RR. The red and blue ports on the RR should be empty. Make sure the correct radio model and serial number were entered during the flash. Verify the radio's serial number entered during the flash matches what is listed on the radio screen. This can be found in the settings of the radio, listed as Device Id, Device Number, or Serial Number.
The light on the Maestro is blinking RED TWICE but the radio is NOT turning on.	If installing a modular radio and it is not turning on, ensure the screen is secured and any trim pieces on the radio have been installed fully. Not installing these fully will prevent radio from powering up and show a 2x red error as well. Test red and yellow wires for DC voltage at radio using a multimeter. Contact support if no voltage on red or yellow.

MAESTRO RR RESET PROCEDURE:

Turn the key to the OFF position, then disconnect all connectors from the module.

Press and hold the module's programming button and connect all the connectors back to the module. Wait, the module's LED will flash RED rapidly (this may take up to 10 seconds).

Release the programming button. Wait, the LED will turn solid GREEN for 2 seconds to show the reset was successful.

TECHNICAL ASSISTANCE

Phone: 1-866-427-2999

Email: maestro.support@idatalink.com

Web: maestro.idatalink.com/support add www.12voldata.com/forum/

IMPORTANT: To ensure proper operation, the aftermarket radio needs to have the latest firmware from the manufacturer. Please visit the radio manufacturer's website and look for any updates pertaining to your radio.

RETAINS STEERING WHEEL CONTROLS, VEHICLE SETTINGS, AND MORE!



PRODUCTS REQUIRED

iDataLink Maestro RR or RR2 Radio Replacement Interface
iDataLink Maestro HRR-MA2 Installation Harness

PROGRAMMED FIRMWARE

ADS-RR(SR)-MA1-DS

ADDITIONAL RESOURCES

[Maestro RR2 Programmable Outputs Guide](#)

OPTIONAL ACCESSORIES

K40
ELECTRONICS
ESCORT

Click here for:
[Radar Installation Guides](#)

ANTENNA ADAPTER (MAY BE REQUIRED)

HEAD UNIT ADAPTER:
ACC-HU-PI01, SON1, KEN1, KEN2, ALP1

WELCOME

Congratulations on the purchase of your iDatalink Maestro RR Radio replacement solution. You are now a few simple steps away from enjoying your new car radio with enhanced features.

Before starting your installation, please ensure that your iDatalink Maestro module is programmed with the correct firmware for your vehicle and that you carefully review the install guide.

Please note that Maestro RR will only retain functionalities that were originally available in the vehicle.

NEED HELP?

 1 866 427-2999

 maestro.support@idatalink.com

 maestro.idatalink.com/support
www.12voltdata.com/forum

TABLE OF CONTENTS

Installation Instructions	3
Wiring Diagram	4
Radio Wire Reference Chart	5
Module Diagnostics	6
Troubleshooting Table	7

INSTALLATION INSTRUCTIONS P1/1

STEP 1

- **Disconnect the negative battery terminal** (not doing so may blow the 7.5A audio fuse 2 under hood during the installation of the radio).
- Remove the factory radio

If using head unit adapter (sold separately), connect HRR-MA2 harness to adapter and skip to step 2.

- Unbox the aftermarket radio and locate its main harness.
- Cut and remove the black 20 pin connector from the HRR-MA2 T-harness and connect the wires, shown in the wiring diagram, from aftermarket radio main harness to the HRR-MA2 T-harness and match the wire functions.

Note: only connect purple/white wire to radio reverse input or module damage will occur.

STEP 2

If the vehicle DOES NOT have a factory amplifier:

- Plug in the extension harness to HRR-MA2 main harness 8-pin black connector.

If the vehicle DOES have a factory amplifier:

- Plug in the extension harness to 8-pin black connector of RCA cable.
- Connect the RCAs to the radio outputs: white/left front, gray/right front, green/left rear, purple/right rear.
- Route the extension harness to the radio tuner in the passenger kick panel.

STEP 3

- Connect both the 18-pin and 28-pin connectors of HRR-MA2 T-harness to the factory radio harness (at CMU, behind/below display).

STEP 4

- Connect the 20-pin adapter (white connector) to the factory radio tuner in the passenger kick panel.
- Connect the adapter's 8-pin black connector to the extension harness.
- Plug the blue POWER ANT terminal to amplified antenna adapter (if required).

STEP 5

- Plug the harnesses into the aftermarket radio.
- Connect the backup cam cable into the aftermarket radio (if equipped).
- Plug the antenna adapter (if required).
- Plug the Data cable to the data port of the aftermarket radio.

Note: On Pioneer radio, ensure that there is nothing plugged into the W/R port.

STEP 6

- Connect all the harnesses to the Maestro RR module.
- **Reconnect the negative battery terminal then test your installation.**

WIRING DIAGRAM

STEP 1

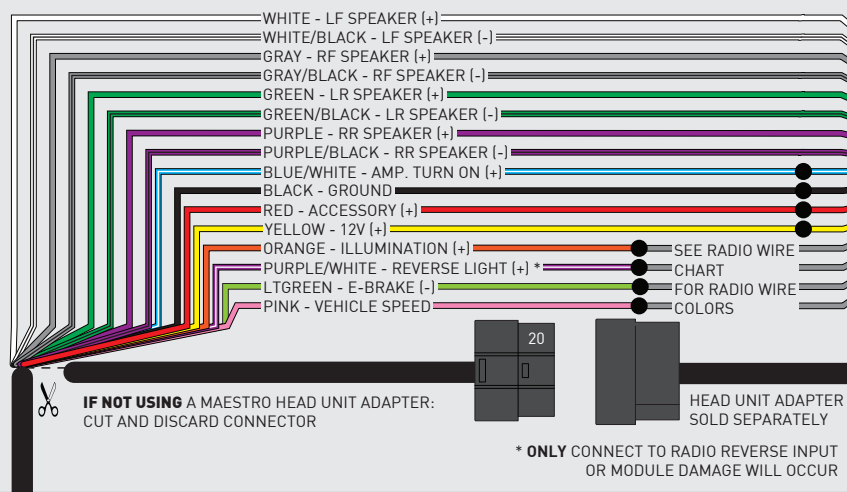

STEP 5

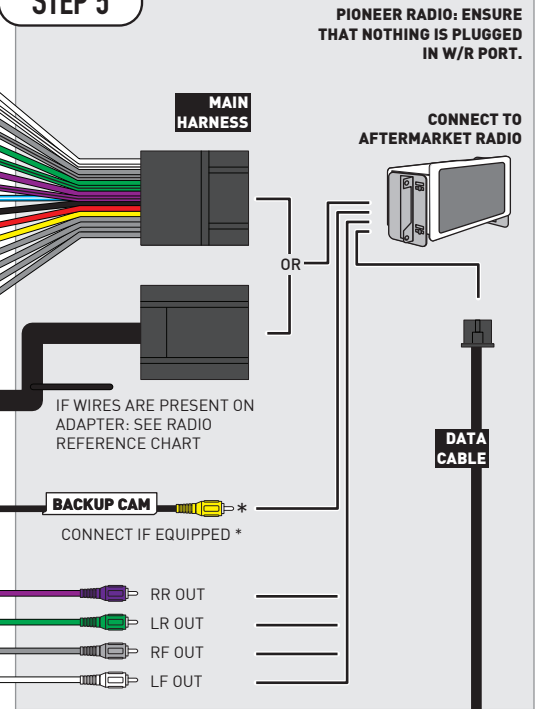

STEP 2

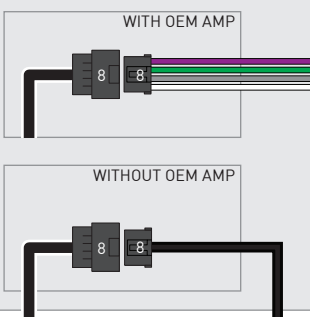

STEP 3

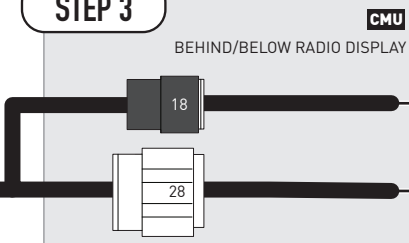

STEP 4

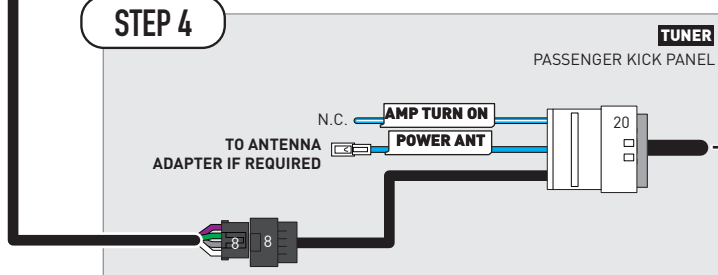

STEP 6

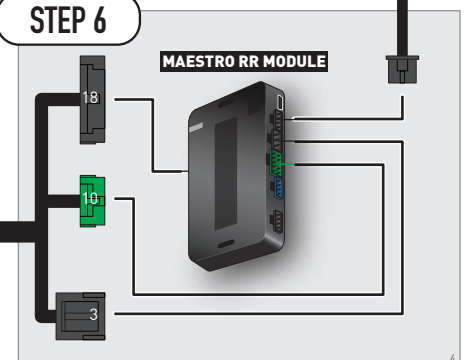

NOT REQUIRED

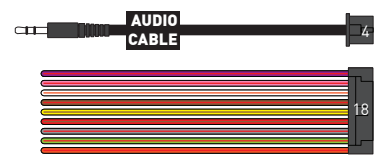
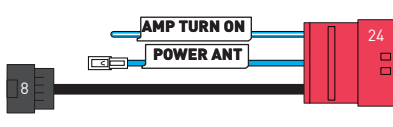
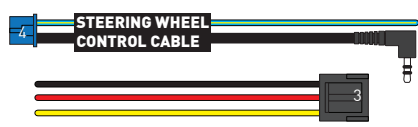

RADIO WIRE REFERENCE CHART

MA2 T-harness Wire Description	Polarity	Wire Color on Maestro T-Harness	Wire Color on Alpine cable	Wire Color on Kenwood cable	Wire Color on Pioneer cable	Wire Color on Sony cable
Illumination	(+)	Orange	N/A	Orange/White	Orange/White	Orange
Reverse Light*	(+)	Purple/White	Orange/White	Purple/White	Purple/White	Purple/White
E-Brake	(-)	Lt Green	Yellow/Blue	Lt Green	Lt Green	Lt Green
VSS (vehicle speed sensor)	(DATA)	Pink	Green/White	Pink	Pink	N/A

Head unit adapter wiring (optional accessory, sold separately)

ACC-HU-ALP1 Wire Description	Polarity	Wire Color on Adapter	Alpine Radio
VSS (vehicle speed sensor)	(DATA)	Green/White	Green/White

ACC-HU-KEN1 Wire Description	Polarity	Wire Color on Adapter	Kenwood Radio
CAM	(+)	Green/Red	Refer to camera/radio manual
CAM	(-)	Green/White	Refer to camera/radio manual
Steering Wheel Controls	(DATA)	Blue/Yellow	n/a

ACC-HU-KEN2 Wire Description	Polarity	Wire Color on Adapter	Kenwood Radio
E-Brake	(-)	LtGreen	LtGreen
Reverse Light*	(+)	Purple/White	Purple/White
Steering Wheel Controls	(DATA)	Blue/Yellow	n/a

* Reverse light wire: Only connect to radio or module damage will occur.

MODULE DIAGNOSTICS



LED 1 Module/Firmware status	LED 2 (RR2) Bluetooth activity	LED STATUS	DIAGNOSTIC
● or ●		RED or GREEN flashing	LED flashes 1 or more times, either red or green, when a steering wheel button is pressed : normal operation.
●		1 RED flash	Module has no firmware. Flash module using Weblink Desktop and log in. Do <u>NOT</u> use DEMO MODE.
●		2 RED flashes	Problem detected. Consult troubleshooting table.
●		1 GREEN flash	After radio boots up : Normal operation.
	●	3 GREEN flashes	Bluetooth is activated. Turns off after one minute: Normal operation.
●	●	OFF	Normal operation (inactive).

VIDEO HELP		Installation, product information, vehicle specific videos.
VERIFY FLASH		Last flash information, steering control configuration, vehicle information.
WEBLINK		Software to program module.

TROUBLESHOOTING TABLE

PROBLEM	SOLUTION
Gauges do not work, radio shows OBD2 Error 1 or Error 2.	If anything is connected to the OBD2 or CAN wires of vehicle (programmer, throttle controller, insurance tracker, etc.) try unplugging it to see if gauges work. If gauges work without it installed, call tech support for options. Reset the RR.
CX-5 and Mazda3 No audio after installing new radio. Factory radio no longer has sound.	Check 7.5 amp "AUDIO 2" fuse located under the hood.
The light on the Maestro is flashing RED ONCE .	There is no firmware on the module. Flash the RR module using Weblink Desktop and log in. Do NOT use DEMO MODE.
The light on the Maestro is blinking RED TWICE and the radio IS turning on.	Ensure the 4-pin data cable is connected between the radio and the RR, and that it is plugged into the black port on the Maestro RR. The red and blue ports on the RR should be empty. Make sure the correct radio model and serial number were entered during the flash. Verify the radio's serial number entered during the flash matches what is listed on the radio screen. This can be found in the settings of the radio, listed as Device Id, Device Number, or Serial Number.
The light on the Maestro is blinking RED TWICE but the radio is NOT turning on.	If installing a modular radio and it is not turning on, ensure the screen is secured and any trim pieces on the radio have been installed fully. Not installing these fully will prevent radio from powering up and show a 2x red error as well. Test red and yellow wires for DC voltage at radio using a multimeter. Contact support if no voltage on red or yellow.

MAESTRO RR RESET PROCEDURE:

Turn the key to the OFF position, then disconnect all connectors from the module.

Press and hold the module's programming button and connect all the connectors back to the module. Wait, the module's LED will flash RED rapidly (this may take up to 10 seconds).

Release the programming button. Wait, the LED will turn solid GREEN for 2 seconds to show the reset was successful.

TECHNICAL ASSISTANCE

Phone: 1-866-427-2999

Email: maestro.support@idatalink.com

Web: maestro.idatalink.com/support add www.12voldata.com/forum/

IMPORTANT: To ensure proper operation, the aftermarket radio needs to have the latest firmware from the manufacturer. Please visit the radio manufacturer's website and look for any updates pertaining to your radio.

RETAINS STEERING WHEEL CONTROLS, VEHICLE SETTINGS, AND MORE!



PRODUCTS REQUIRED

iDatalink Maestro RR or RR2 Radio Replacement Interface
iDatalink Maestro HRR-MA2 Installation Harness

PROGRAMMED FIRMWARE

ADS-RR(SR)-MA1-DS

ADDITIONAL RESOURCES

[Maestro RR2 Programmable Outputs Guide](#)

OPTIONAL ACCESSORIES

K40[™]
ELECTRONICS
ESCORT

Click here for:
[Radar Installation Guides](#)

ANTENNA ADAPTER (MAY BE REQUIRED)

HEAD UNIT ADAPTER:
ACC-HU-PI01, SON1, KEN1, KEN2, ALP1

WELCOME

Congratulations on the purchase of your iDatalink Maestro RR Radio replacement solution. You are now a few simple steps away from enjoying your new car radio with enhanced features.

Before starting your installation, please ensure that your iDatalink Maestro module is programmed with the correct firmware for your vehicle and that you carefully review the install guide.

Please note that Maestro RR will only retain functionalities that were originally available in the vehicle.

NEED HELP?

 1 866 427-2999

 maestro.support@idatalink.com

 maestro.idatalink.com/support
www.12voltdata.com/forum

TABLE OF CONTENTS

Installation Instructions	3
Wiring Diagram	4
Radio Wire Reference Chart	5
Module Diagnostics	6
Troubleshooting Table	7

INSTALLATION INSTRUCTIONS P1/1

STEP 1

- **Disconnect the negative battery terminal** (not doing so may blow the 7.5A audio fuse 2 under hood during the installation of the radio).
- Remove the factory radio

If using head unit adapter (sold separately), connect HRR-MA2 harness to adapter and skip to step 2.

- Unbox the aftermarket radio and locate its main harness.
- Cut and remove the black 20 pin connector from the HRR-MA2 T-harness and connect the wires, shown in the wiring diagram, from aftermarket radio main harness to the HRR-MA2 T-harness and match the wire functions.

Note: only connect purple/white wire to radio reverse input or module damage will occur.

STEP 2

If the vehicle DOES NOT have a factory amplifier:

- Plug in the extension harness to HRR-MA2 main harness 8-pin black connector.

If the vehicle DOES have a factory amplifier:

- Plug in the extension harness to 8-pin black connector of RCA cable.
- Connect the RCAs to the radio outputs: white/left front, gray/right front, green/left rear, purple/right rear.
- Route the extension harness to the radio tuner in the passenger kick panel.

STEP 3

- Connect both the 18-pin and 28-pin connectors of HRR-MA2 T-harness to the factory radio harness (at CMU, behind/below display).

STEP 4

- Connect the 24-pin adapter (red connector) to the factory radio tuner in the passenger kick panel.
- Connect the adapter's 8-pin black connector to the extension harness.
- Plug the blue POWER ANT terminal to amplified antenna adapter (if required).

STEP 5

- Plug the harnesses into the aftermarket radio.
- Connect the backup cam cable into the aftermarket radio (if equipped).
- Plug the antenna adapter (if required).
- Plug the Data cable to the data port of the aftermarket radio.

Note: On Pioneer radio, ensure that there is nothing plugged into the W/R port.

STEP 6

- Connect all the harnesses to the Maestro RR module.
- **Reconnect the negative battery terminal then test your installation.**

WIRING DIAGRAM

STEP 1

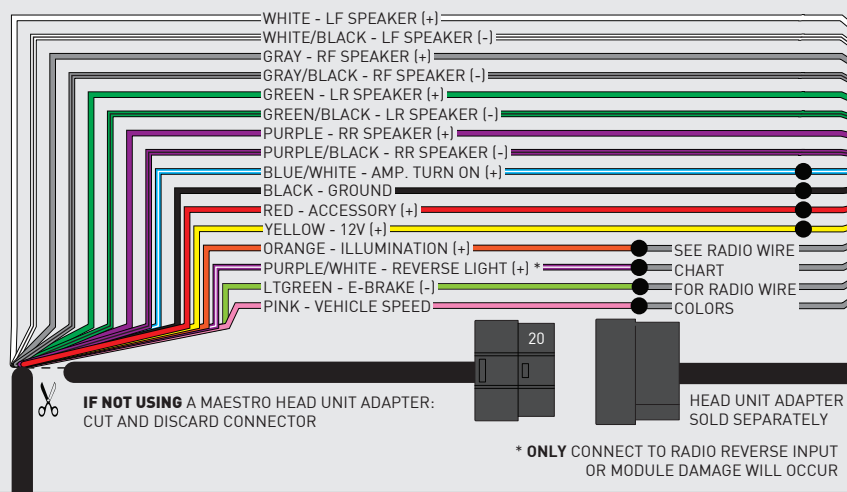

STEP 5

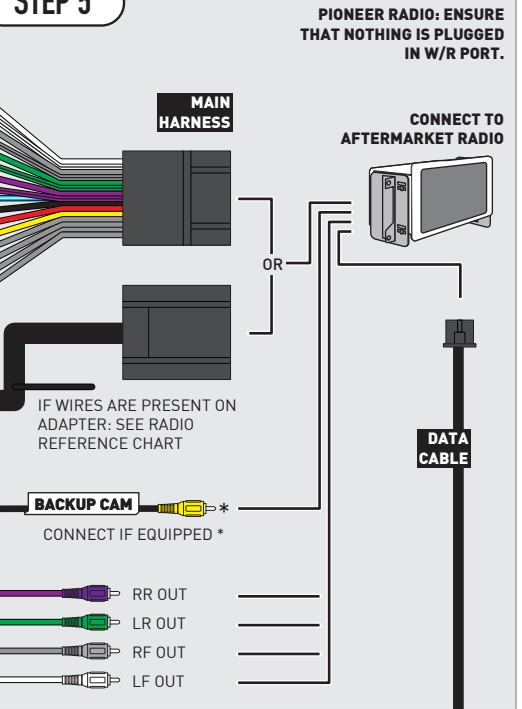

STEP 2

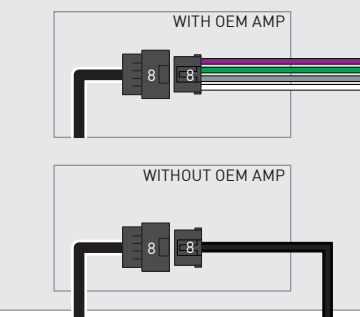

STEP 3

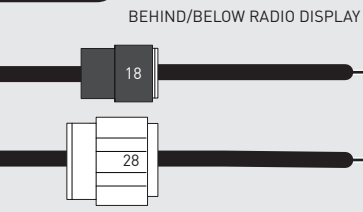

STEP 4

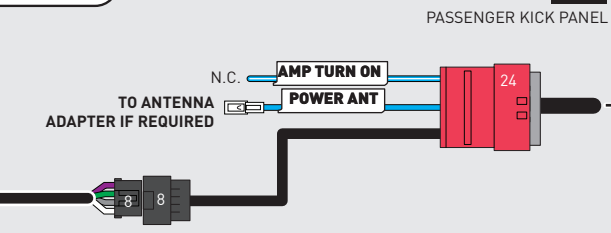

STEP 6

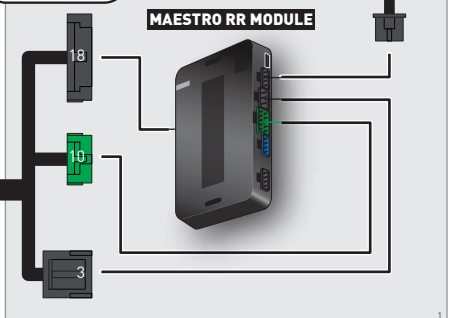

NOT REQUIRED

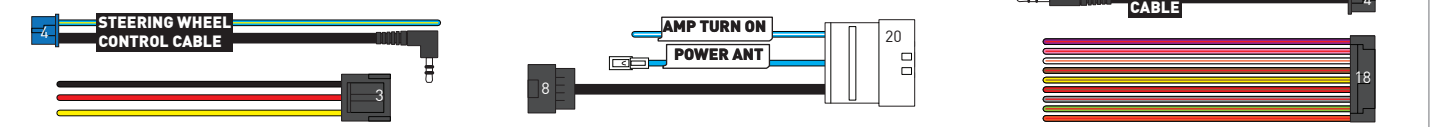

RADIO WIRE REFERENCE CHART

MA2 T-harness Wire Description	Polarity	Wire Color on Maestro T-Harness	Wire Color on Alpine cable	Wire Color on Kenwood cable	Wire Color on Pioneer cable	Wire Color on Sony cable
Illumination	(+)	Orange	N/A	Orange/White	Orange/White	Orange
Reverse Light*	(+)	Purple/White	Orange/White	Purple/White	Purple/White	Purple/White
E-Brake	(-)	Lt Green	Yellow/Blue	Lt Green	Lt Green	Lt Green
VSS (vehicle speed sensor)	(DATA)	Pink	Green/White	Pink	Pink	N/A

Head unit adapter wiring (optional accessory, sold separately)

ACC-HU-ALP1 Wire Description	Polarity	Wire Color on Adapter	Alpine Radio
VSS (vehicle speed sensor)	(DATA)	Green/White	Green/White

ACC-HU-KEN1 Wire Description	Polarity	Wire Color on Adapter	Kenwood Radio
CAM	(+)	Green/Red	Refer to camera/radio manual
CAM	(-)	Green/White	Refer to camera/radio manual
Steering Wheel Controls	(DATA)	Blue/Yellow	n/a

ACC-HU-KEN2 Wire Description	Polarity	Wire Color on Adapter	Kenwood Radio
E-Brake	(-)	LtGreen	LtGreen
Reverse Light*	(+)	Purple/White	Purple/White
Steering Wheel Controls	(DATA)	Blue/Yellow	n/a

* Reverse light wire: Only connect to radio or module damage will occur.

MODULE DIAGNOSTICS



LED 1 Module/Firmware status	LED 2 (RR2) Bluetooth activity	LED STATUS	DIAGNOSTIC
● or ●		RED or GREEN flashing	LED flashes 1 or more times, either red or green, when a steering wheel button is pressed : normal operation.
●		1 RED flash	Module has no firmware. Flash module using Weblink Desktop and log in. Do <u>NOT</u> use DEMO MODE.
●		2 RED flashes	Problem detected. Consult troubleshooting table.
●		1 GREEN flash	After radio boots up : Normal operation.
	●	3 GREEN flashes	Bluetooth is activated. Turns off after one minute: Normal operation.
●	●	OFF	Normal operation (inactive).

VIDEO HELP		Installation, product information, vehicle specific videos.
VERIFY FLASH		Last flash information, steering control configuration, vehicle information.
WEBLINK		Software to program module.

TROUBLESHOOTING TABLE

PROBLEM	SOLUTION
Gauges do not work, radio shows OBD2 Error 1 or Error 2.	If anything is connected to the OBD2 or CAN wires of vehicle (programmer, throttle controller, insurance tracker, etc.) try unplugging it to see if gauges work. If gauges work without it installed, call tech support for options. Reset the RR.
CX-5 and Mazda3 No audio after installing new radio. Factory radio no longer has sound.	Check 7.5 amp "AUDIO 2" fuse located under the hood.
The light on the Maestro is flashing RED ONCE .	There is no firmware on the module. Flash the RR module using Weblink Desktop and log in. Do NOT use DEMO MODE.
The light on the Maestro is blinking RED TWICE and the radio IS turning on.	Ensure the 4-pin data cable is connected between the radio and the RR, and that it is plugged into the black port on the Maestro RR. The red and blue ports on the RR should be empty. Make sure the correct radio model and serial number were entered during the flash. Verify the radio's serial number entered during the flash matches what is listed on the radio screen. This can be found in the settings of the radio, listed as Device Id, Device Number, or Serial Number.
The light on the Maestro is blinking RED TWICE but the radio is NOT turning on.	If installing a modular radio and it is not turning on, ensure the screen is secured and any trim pieces on the radio have been installed fully. Not installing these fully will prevent radio from powering up and show a 2x red error as well. Test red and yellow wires for DC voltage at radio using a multimeter. Contact support if no voltage on red or yellow.

MAESTRO RR RESET PROCEDURE:

Turn the key to the OFF position, then disconnect all connectors from the module.

Press and hold the module's programming button and connect all the connectors back to the module. Wait, the module's LED will flash RED rapidly (this may take up to 10 seconds).

Release the programming button. Wait, the LED will turn solid GREEN for 2 seconds to show the reset was successful.

TECHNICAL ASSISTANCE

Phone: 1-866-427-2999

Email: maestro.support@idatalink.com

Web: maestro.idatalink.com/support add www.12voldata.com/forum/

IMPORTANT: To ensure proper operation, the aftermarket radio needs to have the latest firmware from the manufacturer. Please visit the radio manufacturer's website and look for any updates pertaining to your radio.