



HOW TO USE THIS INSTALL GUIDE

- 1** Open the Bookmarks menu and find your vehicle OR scroll down until you find the install guide for your vehicle.
- 2** Print only the pages for your vehicle using the advanced options in the Print menu.
- 3** Install your Maestro AR according to the guide for your vehicle.

WARNING

Pressing the printer icon or “quick printing” this document will print all of the guides in this compilation.



INSTALL GUIDE FORD EDGE 2011-2018

ENABLE A SEAMLESS AFTERMARKET AMPLIFIER INSTALLATION,
WITHOUT CHANGING YOUR RADIO.



KENWOOD

PRODUCTS REQUIRED

iDatalink Maestro AR Amplifier Replacement Interface
iDatalink Maestro AR-FO2 Installation Harness

OPTIONAL ACCESSORIES

Extension harness provided with
Kenwood amplifier

PROGRAMMED FIRMWARE

ADS-AR-FOR02

NOTICE: Automotive Data Solutions Inc. (ADS) recommends having this installation performed by a certified technician. Logos and trademarks used here in are the properties of their respective owners.

WELCOME

Congratulations on the purchase of your iDatalink Maestro AR Amplifier replacement solution. You are now a few simple steps away from enjoying your new car amplifier.

Before starting your installation, please ensure that your iDatalink Maestro module is programmed with the correct firmware for your vehicle and that you carefully review the install guide.

TABLE OF CONTENTS

Settings and Features	3
Installation Instructions	4
Wiring Diagram	5
Vehicle Wire Reference Chart	6

NEED HELP?

 1 866 427-2999

 maestro.support@idatalink.com

 maestro.idatalink.com/support
www.12voltdata.com/forum

SETTINGS AND FEATURES

CHIME ADJUSTMENT

Chime volume adjustment will only work if the chimes are played by the vehicle speakers (some Ford vehicles generate the chime in the cluster or with dedicated speakers in the back of the vehicle).

CHIME ADJUSTMENT PROCEDURE:

- Set the audio source to OFF.
- Activate door or parking assist chime.
- Adjust the chime volume using the volume knob.

MAESTRO AR PROGRAMMABLE FEATURES

These tone control features can be adjusted in the settings of the radio.

FACTORY CONTROL FEATURES:

- Bass Tone Control
Subwoofer Volume
- Mid Tone Control
Not applicable
- Treble Tone Control
Tweeter Output Gain
- Surround Control
Not applicable
- Speed Compensated Volume
None

INSTALLATION INSTRUCTIONS

STEP 1

- Remove the factory amplifier (refer to wire chart for amplifier location).
- Configure the 2 pin connectors on the AR-F02 T-harness as shown on the wiring diagram.

STEP 2

- Connect the factory amplifier harnesses to the AR-F02 T-harness.

STEP 3

- Connect the wires from the AR-F02 T-harness to the aftermarket amplifier.

Note 1:

If you are running your own speaker wires from the amplifier to the speakers, this step is not necessary.

Note 2:

The amplifier output colors and labels on the F02 T-harness do not correspond to the vehicle. For vehicle specific wiring designation, see the wiring chart.

- Plug the connector from the AR-F02 T-Harness into the aftermarket amplifier.
- Plug the Data cable to the data port of the aftermarket amplifier.

STEP 4

- Connect all the harnesses to the Maestro AR module.

Note 3:

The aftermarket amplifier will not turn OFF with the key, it will shut down when the vehicle goes to sleep.

Note 4:

There will no longer be any audible beeps from the OEM radio when using the radio menus.

- For technical assistance call 1-866-427-2999 or e-mail "maestro.support@idatalink.com". Visit us at "maestro.idatalink.com/support" and "www.12voltdata.com/forum/"

WIRING DIAGRAM

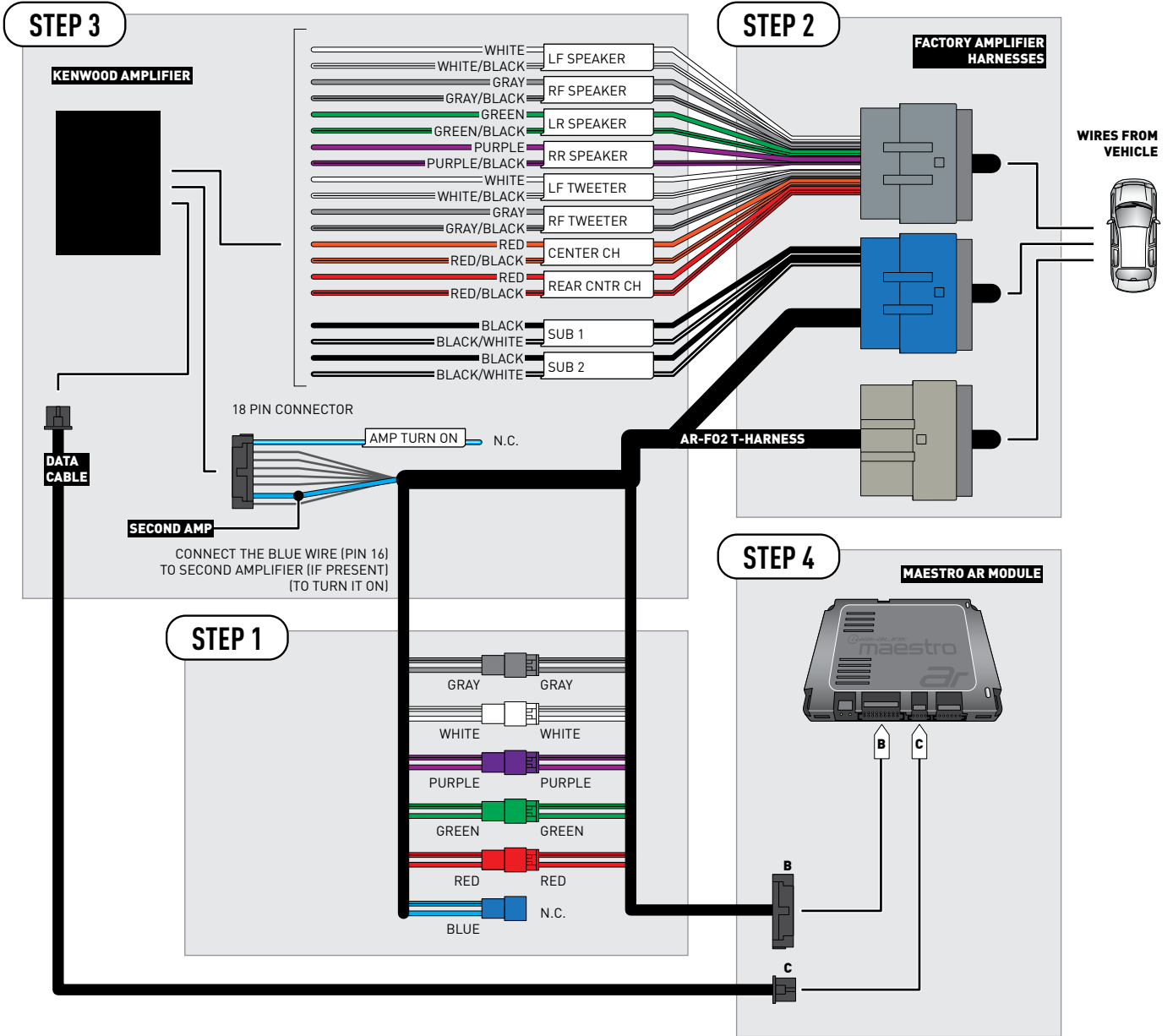

CONNECTION NOT REQUIRED

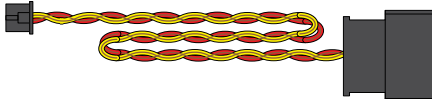

VEHICLE WIRE REFERENCE CHART

T-Harness Wires		Vehicle Wires	
Wire Tag	Wire Color	Speaker Wire Description	Component Position
LF SPEAKER	White	Left Front Speaker (+)	~
	White/Black	Left Front Speaker (-)	
LF TWEETER	White	Left Front Tweeter (+)	~
	White/Black	Left Front Tweeter (-)	
RF SPEAKER	Gray	Right Front Speaker (+)	~
	Gray/Black	Right Front Speaker (-)	
RF TWEETER	Gray	Right Front Tweeter (+)	~
	Gray/Black	Right Front Tweeter (-)	
LR SPEAKER	Green	Left Rear Speaker (+)	~
	Green/Black	Left Rear Speaker (-)	
RR SPEAKER	Purple	Right Rear Speaker (+)	~
	Purple/Black	Right Rear Speaker (-)	
REAR CNTR CH	Red	Rear Tweeter (+)	~
	Red/Black	Rear Tweeter (-)	
CENTER CH	Orange	Center Channel (+)	~
	Orange/Black	Center Channel (-)	
SUB 1	Black	Left Rear Subwoofer (+)	~
	Black/White	Left Rear Subwoofer (-)	
SUB 2	Black	Right Rear Subwoofer (+)	~
	Black/White	Right Rear Subwoofer (-)	

Note: The amplifier output colors and labels on the AR-F02 T-harness do not correspond to the vehicle. For vehicle specific wiring designation, follow this wiring chart.

Amplifier location

(2011-2014): Right C-pillar

(2015-2017): Behind left quarter panel



INSTALL GUIDE FORD ESCAPE 2013-2016

ENABLE A SEAMLESS AFTERMARKET AMPLIFIER INSTALLATION,
WITHOUT CHANGING YOUR RADIO.



KENWOOD

PRODUCTS REQUIRED

iDatalink Maestro AR Amplifier Replacement Interface
iDatalink Maestro AR-F02 Installation Harness

OPTIONAL ACCESSORIES

Extension harness provided with
Kenwood amplifier

PROGRAMMED FIRMWARE

ADS-AR-FOR02

NOTICE: Automotive Data Solutions Inc. (ADS) recommends having this installation performed by a certified technician. Logos and trademarks used here in are the properties of their respective owners.

WELCOME

Congratulations on the purchase of your iDatalink Maestro AR Amplifier replacement solution. You are now a few simple steps away from enjoying your new car amplifier.

Before starting your installation, please ensure that your iDatalink Maestro module is programmed with the correct firmware for your vehicle and that you carefully review the install guide.

TABLE OF CONTENTS

Settings and Features	3
Installation Instructions	4
Wiring Diagram	5
Vehicle Wire Reference Chart	6

NEED HELP?

 1 866 427-2999

 maestro.support@idatalink.com

 maestro.idatalink.com/support
www.12voltdata.com/forum

SETTINGS AND FEATURES

CHIME ADJUSTMENT

Chime volume adjustment will only work if the chimes are played by the vehicle speakers (some Ford vehicles generate the chime in the cluster or with dedicated speakers in the back of the vehicle).

CHIME ADJUSTMENT PROCEDURE:

- Set the audio source to OFF.
- Activate door or parking assist chime.
- Adjust the chime volume using the volume knob.

MAESTRO AR PROGRAMMABLE FEATURES

These tone control features can be adjusted in the settings of the radio.

FACTORY CONTROL FEATURES:

- Bass Tone Control
Subwoofer Volume
- Mid Tone Control
Not applicable
- Treble Tone Control
Tweeter Output Gain
- Surround Control
Not applicable
- Speed Compensated Volume
None

INSTALLATION INSTRUCTIONS

STEP 1

- Remove the factory amplifier (refer to wire chart for amplifier location).
- Configure the 2 pin connectors on the AR-F02 T-harness as shown on the wiring diagram.

STEP 2

- Connect the factory amplifier harnesses to the AR-F02 T-harness.

STEP 3

- Connect the wires from the AR-F02 T-harness to the aftermarket amplifier.

Note 1:

If you are running your own speaker wires from the amplifier to the speakers, this step is not necessary.

Note 2:

The amplifier output colors and labels on the F02 T-harness do not correspond to the vehicle. For vehicle specific wiring designation, see the wiring chart.

- Plug the connector from the AR-F02 T-Harness into the aftermarket amplifier.
- Plug the Data cable to the data port of the aftermarket amplifier.

STEP 4

- Connect all the harnesses to the Maestro AR module.

Note 3:

The aftermarket amplifier will not turn OFF with the key, it will shut down when the vehicle goes to sleep.

Note 4:

There will no longer be any audible beeps from the OEM radio when using the radio menus.

- For technical assistance call 1-866-427-2999 or e-mail "maestro.support@idatalink.com". Visit us at "maestro.idatalink.com/support" and "www.12voltdata.com/forum/"

WIRING DIAGRAM

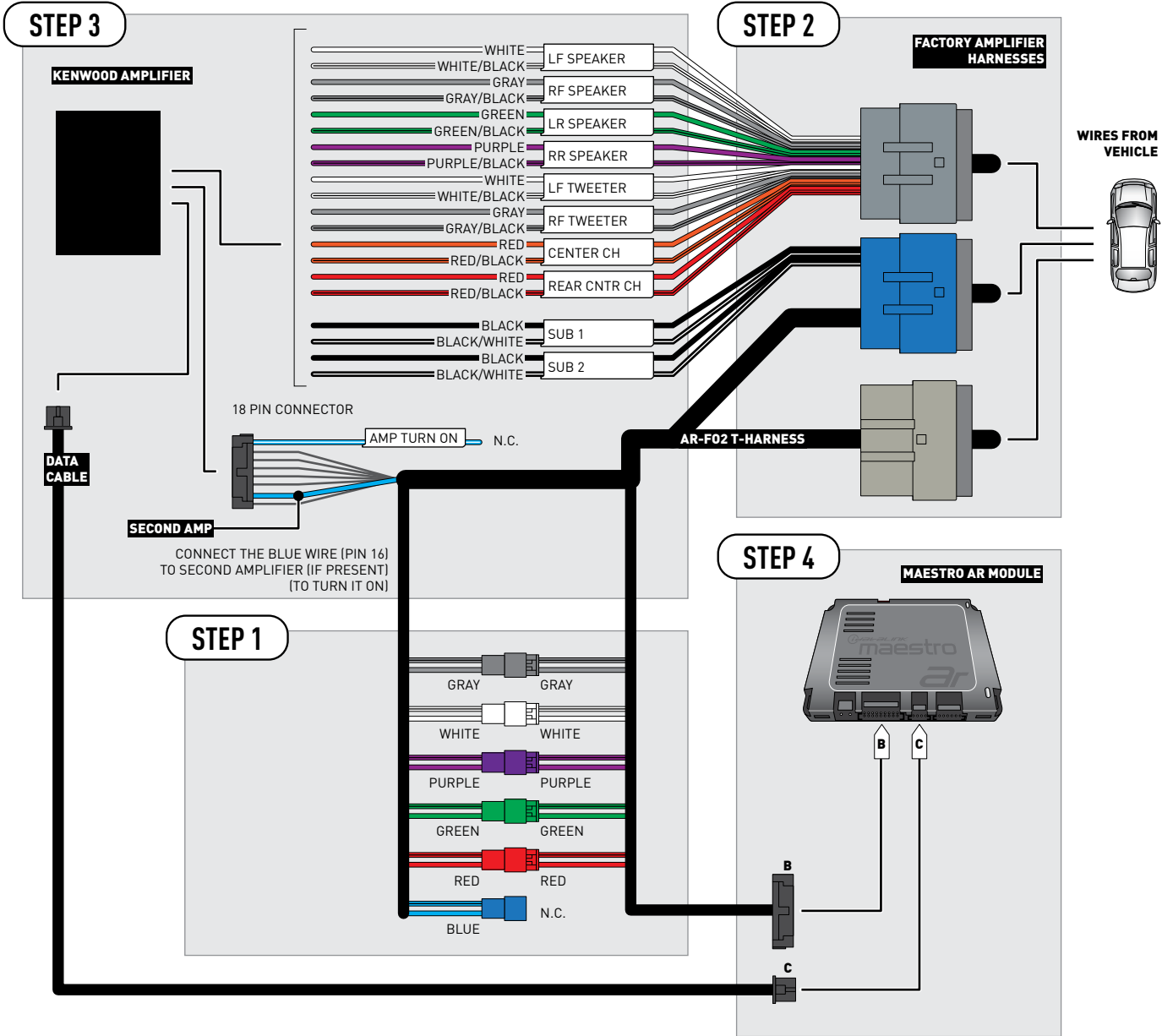

CONNECTION NOT REQUIRED

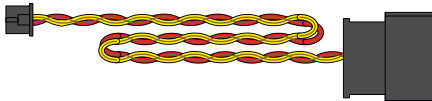

VEHICLE WIRE REFERENCE CHART

T-Harness Wires		Vehicle Wires	
Wire Tag	Wire Color	Speaker Wire Description	Component Position
LF SPEAKER	White	Left Front Speaker (+)	~
	White/Black	Left Front Speaker (-)	
LF TWEETER	White	Left Front Tweeter (+)	~
	White/Black	Left Front Tweeter (-)	
RF SPEAKER	Gray	Right Front Speaker (+)	~
	Gray/Black	Right Front Speaker (-)	
RF TWEETER	Gray	Right Front Tweeter (+)	~
	Gray/Black	Right Front Tweeter (-)	
LR SPEAKER	Green	Left Rear Speaker (+)	~
	Green/Black	Left Rear Speaker (-)	
RR SPEAKER	Purple	Right Rear Speaker (+)	~
	Purple/Black	Right Rear Speaker (-)	
REAR CNTR CH	Red	n/a	~
	Red/Black	n/a	
CENTER CH	Orange	Center Channel (+)	~
	Orange/Black	Center Channel (-)	
SUB 1	Black	Left Rear Subwoofer (+)	~
	Black/White	Left Rear Subwoofer (-)	
SUB 2	Black	Right Rear Subwoofer (+)	~
	Black/White	Right Rear Subwoofer (-)	

Note: The amplifier output colors and labels on the AR-F02 T-harness do not correspond to the vehicle. For vehicle specific wiring designation, follow this wiring chart.

Amplifier location

Left front of luggage compartment



INSTALL GUIDE FORD EXPEDITION 2015-2017

ENABLE A SEAMLESS AFTERMARKET AMPLIFIER INSTALLATION,
WITHOUT CHANGING YOUR RADIO.



KENWOOD

PRODUCTS REQUIRED

iDatalink Maestro AR Amplifier Replacement Interface
iDatalink Maestro AR-FO2 Installation Harness

OPTIONAL ACCESSORIES

Extension harness provided with
Kenwood amplifier

PROGRAMMED FIRMWARE

ADS-AR-FOR02

NOTICE: Automotive Data Solutions Inc. (ADS) recommends having this installation performed by a certified technician. Logos and trademarks used here in are the properties of their respective owners.

WELCOME

Congratulations on the purchase of your iDatalink Maestro AR Amplifier replacement solution. You are now a few simple steps away from enjoying your new car amplifier.

Before starting your installation, please ensure that your iDatalink Maestro module is programmed with the correct firmware for your vehicle and that you carefully review the install guide.

TABLE OF CONTENTS

Settings and Features	3
Installation Instructions	4
Wiring Diagram	5
Vehicle Wire Reference Chart	6

NEED HELP?

 1 866 427-2999

 maestro.support@idatalink.com

 maestro.idatalink.com/support
www.12voltdata.com/forum

SETTINGS AND FEATURES

CHIME ADJUSTMENT

Chime volume adjustment will only work if the chimes are played by the vehicle speakers (some Ford vehicles generate the chime in the cluster or with dedicated speakers in the back of the vehicle).

CHIME ADJUSTMENT PROCEDURE:

- Set the audio source to OFF.
- Activate door or parking assist chime.
- Adjust the chime volume using the volume knob.

MAESTRO AR PROGRAMMABLE FEATURES

These tone control features can be adjusted in the settings of the radio.

FACTORY CONTROL FEATURES:

- Bass Tone Control
Subwoofer Volume
- Mid Tone Control
Not applicable
- Treble Tone Control
Tweeter Output Gain
- Surround Control
Not applicable
- Speed Compensated Volume
None

INSTALLATION INSTRUCTIONS

STEP 1

- Remove the factory amplifier (refer to wire chart for amplifier location).
- Configure the 2 pin connectors on the AR-F02 T-harness as shown on the wiring diagram.

STEP 2

- Connect the factory amplifier harnesses to the AR-F02 T-harness.

STEP 3

- Connect the wires from the AR-F02 T-harness to the aftermarket amplifier.

Note 1:

If you are running your own speaker wires from the amplifier to the speakers, this step is not necessary.

Note 2:

The amplifier output colors and labels on the F02 T-harness do not correspond to the vehicle. For vehicle specific wiring designation, see the wiring chart.

- Plug the connector from the AR-F02 T-Harness into the aftermarket amplifier.
- Plug the Data cable to the data port of the aftermarket amplifier.

STEP 4

- Connect all the harnesses to the Maestro AR module.

Note 3:

The aftermarket amplifier will not turn OFF with the key, it will shut down when the vehicle goes to sleep.

Note 4:

There will no longer be any audible beeps from the OEM radio when using the radio menus.

- For technical assistance call 1-866-427-2999 or e-mail "maestro.support@idatalink.com". Visit us at "maestro.idatalink.com/support" and "www.12voltdata.com/forum/"

WIRING DIAGRAM

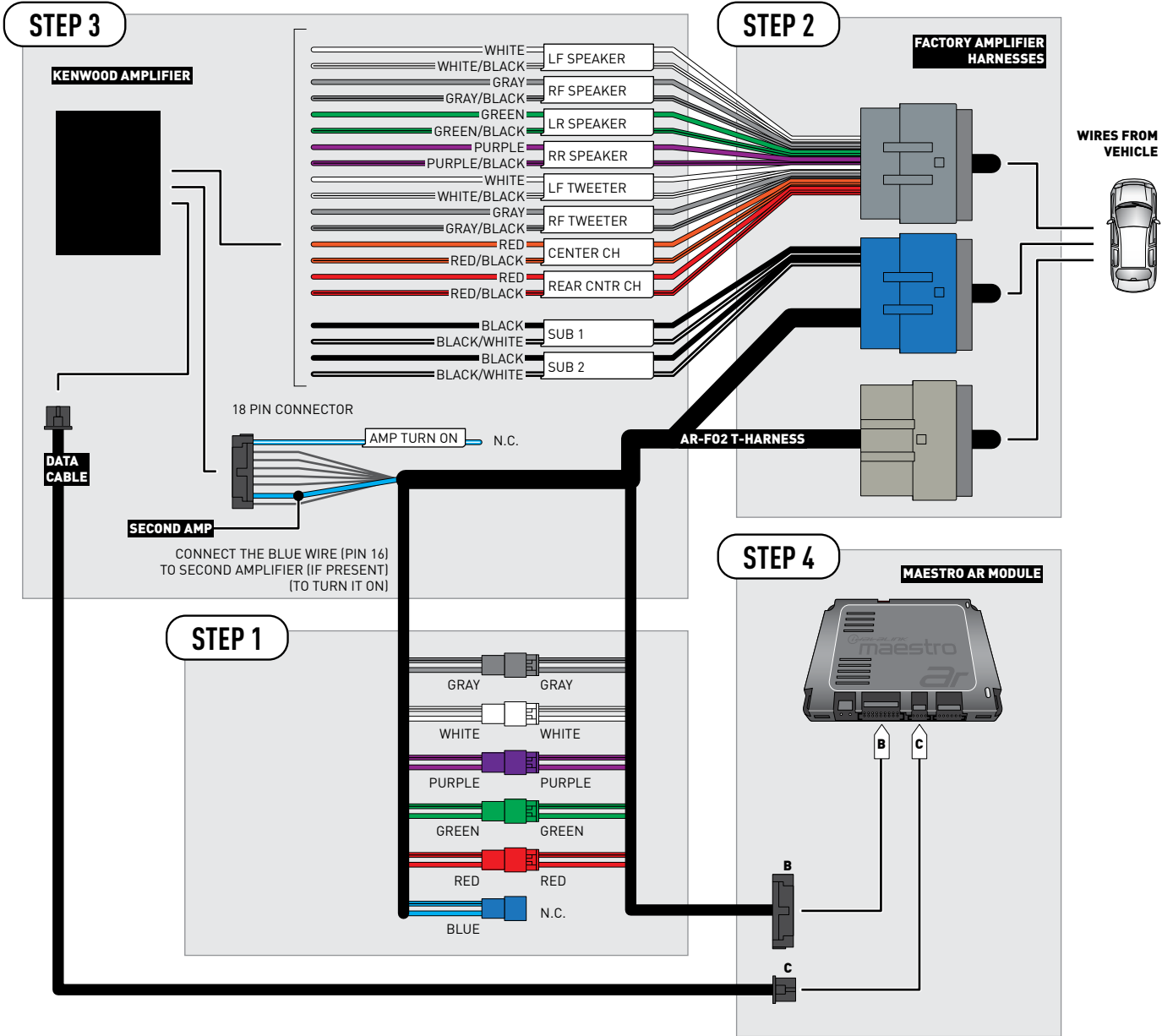

CONNECTION NOT REQUIRED

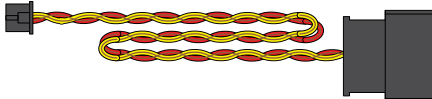

VEHICLE WIRE REFERENCE CHART

T-Harness Wires		Vehicle Wires	
Wire Tag	Wire Color	Speaker Wire Description	Component Position
LF SPEAKER	White	Left Front Speaker (+)	~
	White/Black	Left Front Speaker (-)	
LF TWEETER	White	Left Front Tweeter (+)	~
	White/Black	Left Front Tweeter (-)	
RF SPEAKER	Gray	Right Front Speaker (+)	~
	Gray/Black	Right Front Speaker (-)	
RF TWEETER	Gray	Right Front Tweeter (+)	~
	Gray/Black	Right Front Tweeter (-)	
LR SPEAKER	Green	Left Rear Speaker (+)	~
	Green/Black	Left Rear Speaker (-)	
RR SPEAKER	Purple	Right Rear Speaker (+)	~
	Purple/Black	Right Rear Speaker (-)	
REAR CNTR CH	Red	Mono Rear Tweeters (+)	~
	Red/Black	Mono Rear Tweeters (-)	
CENTER CH	Orange	Center Channel (+)	~
	Orange/Black	Center Channel (-)	
SUB 1	Black	Left Rear Subwoofer (+)	~
	Black/White	Left Rear Subwoofer (-)	
SUB 2	Black	Right Rear Subwoofer (+)	~
	Black/White	Right Rear Subwoofer (-)	

Note: The amplifier output colors and labels on the AR-F02 T-harness do not correspond to the vehicle. For vehicle specific wiring designation, follow this wiring chart.

Amplifier location

Behind left quarter panel



INSTALL GUIDE FORD EXPLORER 2011-2015

ENABLE A SEAMLESS AFTERMARKET AMPLIFIER INSTALLATION,
WITHOUT CHANGING YOUR RADIO.



KENWOOD

PRODUCTS REQUIRED

iDatalink Maestro AR Amplifier Replacement Interface
iDatalink Maestro AR-F02 Installation Harness

OPTIONAL ACCESSORIES

Extension harness provided with
Kenwood amplifier

PROGRAMMED FIRMWARE

ADS-AR-FOR02

NOTICE: Automotive Data Solutions Inc. (ADS) recommends having this installation performed by a certified technician. Logos and trademarks used here in are the properties of their respective owners.

WELCOME

Congratulations on the purchase of your iDatalink Maestro AR Amplifier replacement solution. You are now a few simple steps away from enjoying your new car amplifier.

Before starting your installation, please ensure that your iDatalink Maestro module is programmed with the correct firmware for your vehicle and that you carefully review the install guide.

TABLE OF CONTENTS

Settings and Features	3
Installation Instructions	4
Wiring Diagram	5
Vehicle Wire Reference Chart	6

NEED HELP?

 1 866 427-2999

 maestro.support@idatalink.com

 maestro.idatalink.com/support
www.12voltdata.com/forum

SETTINGS AND FEATURES

CHIME ADJUSTMENT

Chime volume adjustment will only work if the chimes are played by the vehicle speakers (some Ford vehicles generate the chime in the cluster or with dedicated speakers in the back of the vehicle).

CHIME ADJUSTMENT PROCEDURE:

- Set the audio source to OFF.
- Activate door or parking assist chime.
- Adjust the chime volume using the volume knob.

MAESTRO AR PROGRAMMABLE FEATURES

These tone control features can be adjusted in the settings of the radio.

FACTORY CONTROL FEATURES:

- Bass Tone Control
Subwoofer Volume
- Mid Tone Control
Not applicable
- Treble Tone Control
Tweeter Output Gain
- Surround Control
Not applicable
- Speed Compensated Volume
None

INSTALLATION INSTRUCTIONS

STEP 1

- Remove the factory amplifier (refer to wire chart for amplifier location).
- Configure the 2 pin connectors on the AR-F02 T-harness as shown on the wiring diagram.

STEP 2

- Connect the factory amplifier harnesses to the AR-F02 T-harness.

STEP 3

- Connect the wires from the AR-F02 T-harness to the aftermarket amplifier.

Note 1:

If you are running your own speaker wires from the amplifier to the speakers, this step is not necessary.

Note 2:

The amplifier output colors and labels on the F02 T-harness do not correspond to the vehicle. For vehicle specific wiring designation, see the wiring chart.

- Plug the connector from the AR-F02 T-Harness into the aftermarket amplifier.
- Plug the Data cable to the data port of the aftermarket amplifier.

STEP 4

- Connect all the harnesses to the Maestro AR module.

Note 3:

The aftermarket amplifier will not turn OFF with the key, it will shut down when the vehicle goes to sleep.

Note 4:

There will no longer be any audible beeps from the OEM radio when using the radio menus.

- For technical assistance call 1-866-427-2999 or e-mail "maestro.support@idatalink.com". Visit us at "maestro.idatalink.com/support" and "www.12voltdata.com/forum/"

WIRING DIAGRAM

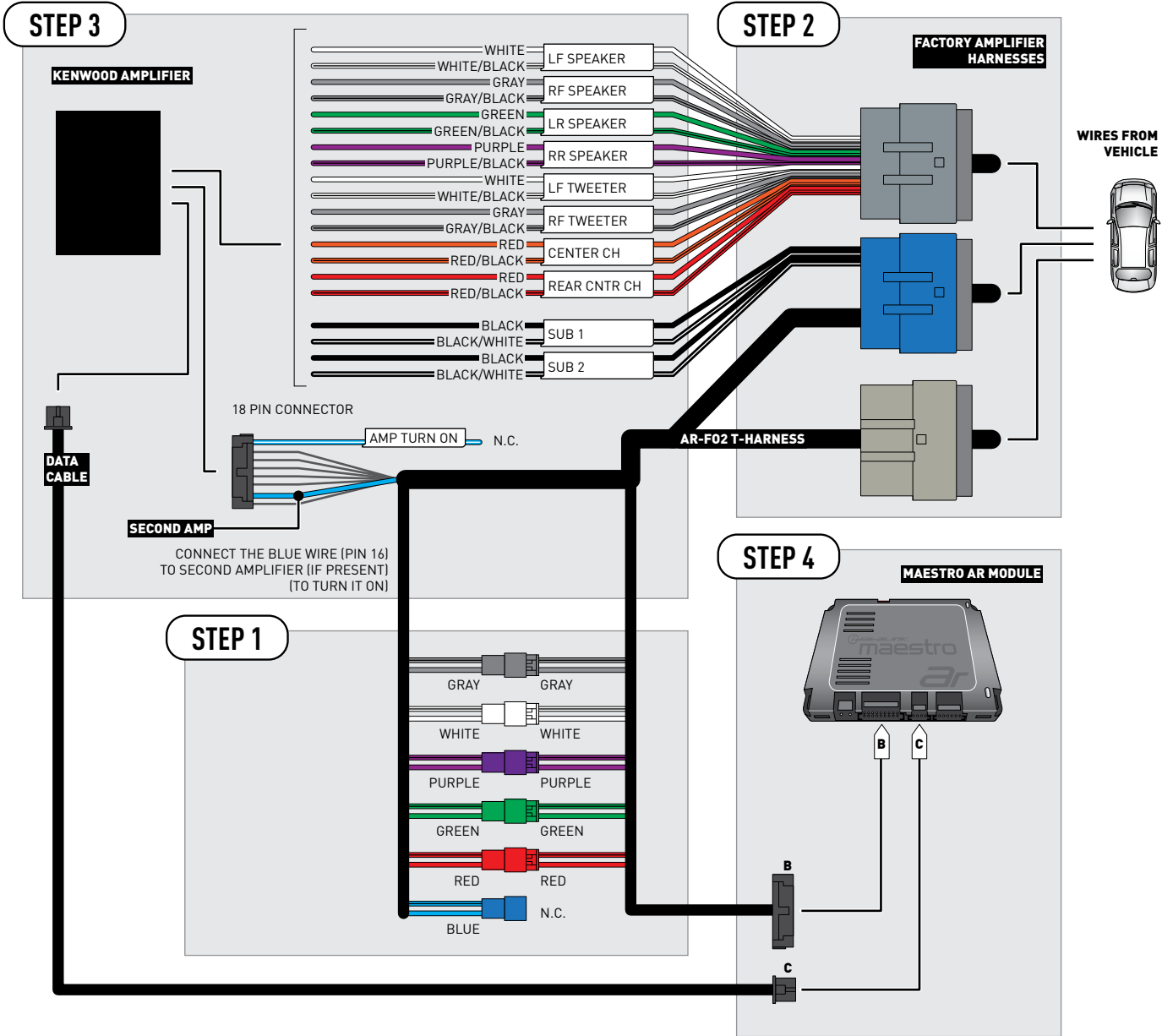

CONNECTION NOT REQUIRED

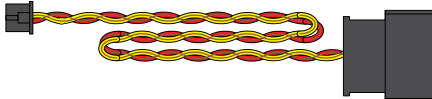

VEHICLE WIRE REFERENCE CHART

T-Harness Wires		Vehicle Wires	
Wire Tag	Wire Color	Speaker Wire Description	Component Position
LF SPEAKER	White	Left Front Speaker (+)	~
	White/Black	Left Front Speaker (-)	
LF TWEETER	White	Left Front Tweeter (+)	~
	White/Black	Left Front Tweeter (-)	
RF SPEAKER	Gray	Right Front Speaker (+)	~
	Gray/Black	Right Front Speaker (-)	
RF TWEETER	Gray	Right Front Tweeter (+)	~
	Gray/Black	Right Front Tweeter (-)	
LR SPEAKER	Green	Left Rear Speaker (+)	~
	Green/Black	Left Rear Speaker (-)	
RR SPEAKER	Purple	Right Rear Speaker (+)	~
	Purple/Black	Right Rear Speaker (-)	
REAR CNTR CH	Red	Mono Rear Tweeters (+)	~
	Red/Black	Mono Rear Tweeters (-)	
CENTER CH	Orange	Center Channel (+)	~
	Orange/Black	Center Channel (-)	
SUB 1	Black	Left Rear Subwoofer (+)	~
	Black/White	Left Rear Subwoofer (-)	
SUB 2	Black	Right Rear Subwoofer (+)	~
	Black/White	Right Rear Subwoofer (-)	

Note: The amplifier output colors and labels on the AR-F02 T-harness do not correspond to the vehicle. For vehicle specific wiring designation, follow this wiring chart.

Amplifier location

Base of right C-pillar



INSTALL GUIDE FORD EXPLORER 2016-2017

ENABLE A SEAMLESS AFTERMARKET AMPLIFIER INSTALLATION,
WITHOUT CHANGING YOUR RADIO.



KENWOOD

PRODUCTS REQUIRED

iDatalink Maestro AR Amplifier Replacement Interface
iDatalink Maestro AR-F02 Installation Harness

OPTIONAL ACCESSORIES

Extension harness provided with
Kenwood amplifier

PROGRAMMED FIRMWARE

ADS-AR-FOR02

NOTICE: Automotive Data Solutions Inc. (ADS) recommends having this installation performed by a certified technician. Logos and trademarks used here in are the properties of their respective owners.

WELCOME

Congratulations on the purchase of your iDatalink Maestro AR Amplifier replacement solution. You are now a few simple steps away from enjoying your new car amplifier.

Before starting your installation, please ensure that your iDatalink Maestro module is programmed with the correct firmware for your vehicle and that you carefully review the install guide.

TABLE OF CONTENTS

Settings and Features	3
Installation Instructions	4
Wiring Diagram	5
Vehicle Wire Reference Chart	6

NEED HELP?

 1 866 427-2999

 maestro.support@idatalink.com

 maestro.idatalink.com/support
www.12voltdata.com/forum

SETTINGS AND FEATURES

CHIME ADJUSTMENT

Chime volume adjustment will only work if the chimes are played by the vehicle speakers (some Ford vehicles generate the chime in the cluster or with dedicated speakers in the back of the vehicle).

CHIME ADJUSTMENT PROCEDURE:

- Set the audio source to OFF.
- Activate door or parking assist chime.
- Adjust the chime volume using the volume knob.

MAESTRO AR PROGRAMMABLE FEATURES

These tone control features can be adjusted in the settings of the radio.

FACTORY CONTROL FEATURES:

- Bass Tone Control
Subwoofer Volume
- Mid Tone Control
Not applicable
- Treble Tone Control
Tweeter Output Gain
- Surround Control
Not applicable
- Speed Compensated Volume
None

INSTALLATION INSTRUCTIONS

STEP 1

- Remove the factory amplifier (refer to wire chart for amplifier location).
- Configure the 2 pin connectors on the AR-F02 T-harness as shown on the wiring diagram.

STEP 2

- Connect the factory amplifier harnesses to the AR-F02 T-harness.

STEP 3

- Connect the wires from the AR-F02 T-harness to the aftermarket amplifier.

Note 1:

If you are running your own speaker wires from the amplifier to the speakers, this step is not necessary.

Note 2:

The amplifier output colors and labels on the F02 T-harness do not correspond to the vehicle. For vehicle specific wiring designation, see the wiring chart.

- Plug the connector from the AR-F02 T-Harness into the aftermarket amplifier.
- Plug the Data cable to the data port of the aftermarket amplifier.

STEP 4

- Connect all the harnesses to the Maestro AR module.

Note 3:

The aftermarket amplifier will not turn OFF with the key, it will shut down when the vehicle goes to sleep.

Note 4:

There will no longer be any audible beeps from the OEM radio when using the radio menus.

- For technical assistance call 1-866-427-2999 or e-mail "maestro.support@idatalink.com". Visit us at "maestro.idatalink.com/support" and "www.12voltdata.com/forum/"

WIRING DIAGRAM

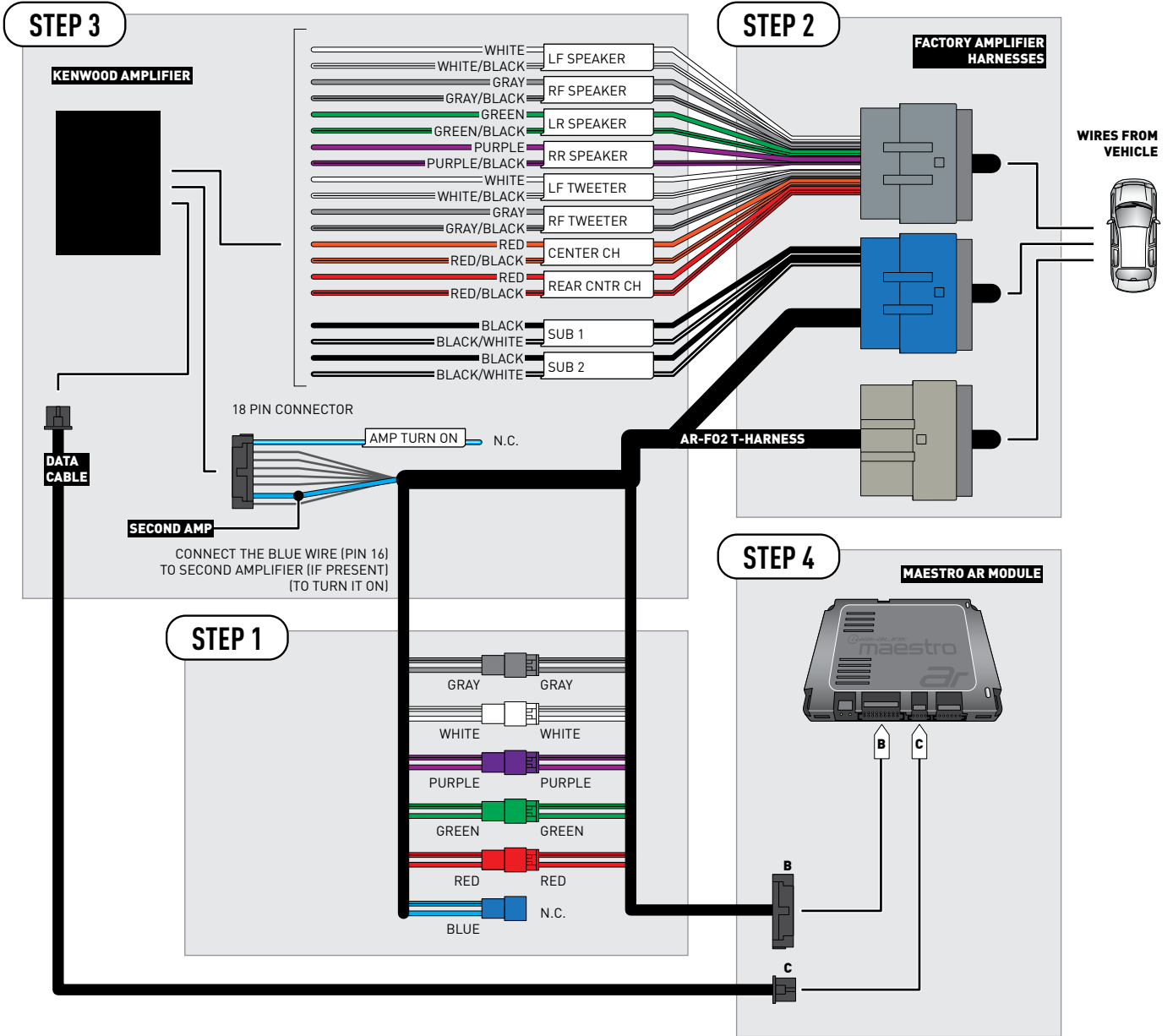

CONNECTION NOT REQUIRED

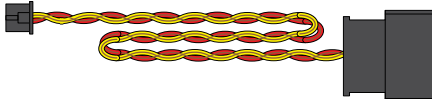

VEHICLE WIRE REFERENCE CHART

T-Harness Wires		Vehicle Wires	
Wire Tag	Wire Color	Speaker Wire Description	Component Position
LF SPEAKER	White	Left Front Speaker (+)	~
	White/Black	Left Front Speaker (-)	
LF TWEETER	White	Left Front Tweeter (+)	~
	White/Black	Left Front Tweeter (-)	
RF SPEAKER	Gray	Right Front Speaker (+)	~
	Gray/Black	Right Front Speaker (-)	
RF TWEETER	Gray	Right Front Tweeter (+)	~
	Gray/Black	Right Front Tweeter (-)	
LR SPEAKER	Green	Left Rear Speaker (+)	~
	Green/Black	Left Rear Speaker (-)	
RR SPEAKER	Purple	Right Rear Speaker (+)	~
	Purple/Black	Right Rear Speaker (-)	
REAR CNTR CH	Red	Mono Rear Tweeters (+)	~
	Red/Black	Mono Rear Tweeters (-)	
CENTER CH	Orange	Center Channel (+)	~
	Orange/Black	Center Channel (-)	
SUB 1	Black	Left Rear Speaker (+)	~
	Black/White	Left Rear Speaker (-)	
SUB 2	Black	Right Rear Speaker (+)	~
	Black/White	Right Rear Speaker (-)	

Note 1: The amplifier output colors and labels on the AR-F02 T-harness do not correspond to the vehicle. For vehicle specific wiring designation, follow this wiring chart.

Note 2: The wires for the subwoofer are not pinned in the F02 harness. Because the subwoofer is located near the factory amplifier, the wires can be connected directly at the subwoofer instead.

Amplifier location

Base of right C-pillar



INSTALL GUIDE FORD F150 2013-2017

ENABLE A SEAMLESS AFTERMARKET AMPLIFIER INSTALLATION,
WITHOUT CHANGING YOUR RADIO.



KENWOOD

PRODUCTS REQUIRED

iDatalink Maestro AR Amplifier Replacement Interface
iDatalink Maestro AR-F02 Installation Harness

OPTIONAL ACCESSORIES

Extension harness provided with
Kenwood amplifier

PROGRAMMED FIRMWARE

ADS-AR-FOR02

NOTICE: Automotive Data Solutions Inc. (ADS) recommends having this installation performed by a certified technician. Logos and trademarks used here in are the properties of their respective owners.

WELCOME

Congratulations on the purchase of your iDatalink Maestro AR Amplifier replacement solution. You are now a few simple steps away from enjoying your new car amplifier.

Before starting your installation, please ensure that your iDatalink Maestro module is programmed with the correct firmware for your vehicle and that you carefully review the install guide.

TABLE OF CONTENTS

Settings and Features	3
Installation Instructions	4
Wiring Diagram	5
Vehicle Wire Reference Chart	6

NEED HELP?

 1 866 427-2999

 maestro.support@idatalink.com

 maestro.idatalink.com/support
www.12voltdata.com/forum

SETTINGS AND FEATURES

CHIME ADJUSTMENT

Chime volume adjustment will only work if the chimes are played by the vehicle speakers (some Ford vehicles generate the chime in the cluster or with dedicated speakers in the back of the vehicle).

CHIME ADJUSTMENT PROCEDURE:

- Set the audio source to OFF.
- Activate door or parking assist chime.
- Adjust the chime volume using the volume knob.

MAESTRO AR PROGRAMMABLE FEATURES

These tone control features can be adjusted in the settings of the radio.

FACTORY CONTROL FEATURES:

- Bass Tone Control
Subwoofer Volume
- Mid Tone Control
Not applicable
- Treble Tone Control
Tweeter Output Gain
- Surround Control
Not applicable
- Speed Compensated Volume
None

INSTALLATION INSTRUCTIONS

STEP 1

- Remove the factory amplifier (refer to wire chart for amplifier location).
- Configure the 2 pin connectors on the AR-F02 T-harness as shown on the wiring diagram.

STEP 2

- Connect the factory amplifier harnesses to the AR-F02 T-harness.

STEP 3

- Connect the wires from the AR-F02 T-harness to the aftermarket amplifier.

Note 1:

If you are running your own speaker wires from the amplifier to the speakers, this step is not necessary.

Note 2:

The amplifier output colors and labels on the F02 T-harness do not correspond to the vehicle. For vehicle specific wiring designation, see the wiring chart.

- Plug the connector from the AR-F02 T-Harness into the aftermarket amplifier.
- Plug the Data cable to the data port of the aftermarket amplifier.

STEP 4

- Connect all the harnesses to the Maestro AR module.

Note 3:

The aftermarket amplifier will not turn OFF with the key, it will shut down when the vehicle goes to sleep.

Note 4:

There will no longer be any audible beeps from the OEM radio when using the radio menus.

- For technical assistance call 1-866-427-2999 or e-mail "maestro.support@idatalink.com". Visit us at "maestro.idatalink.com/support" and "www.12voltdata.com/forum/"

WIRING DIAGRAM

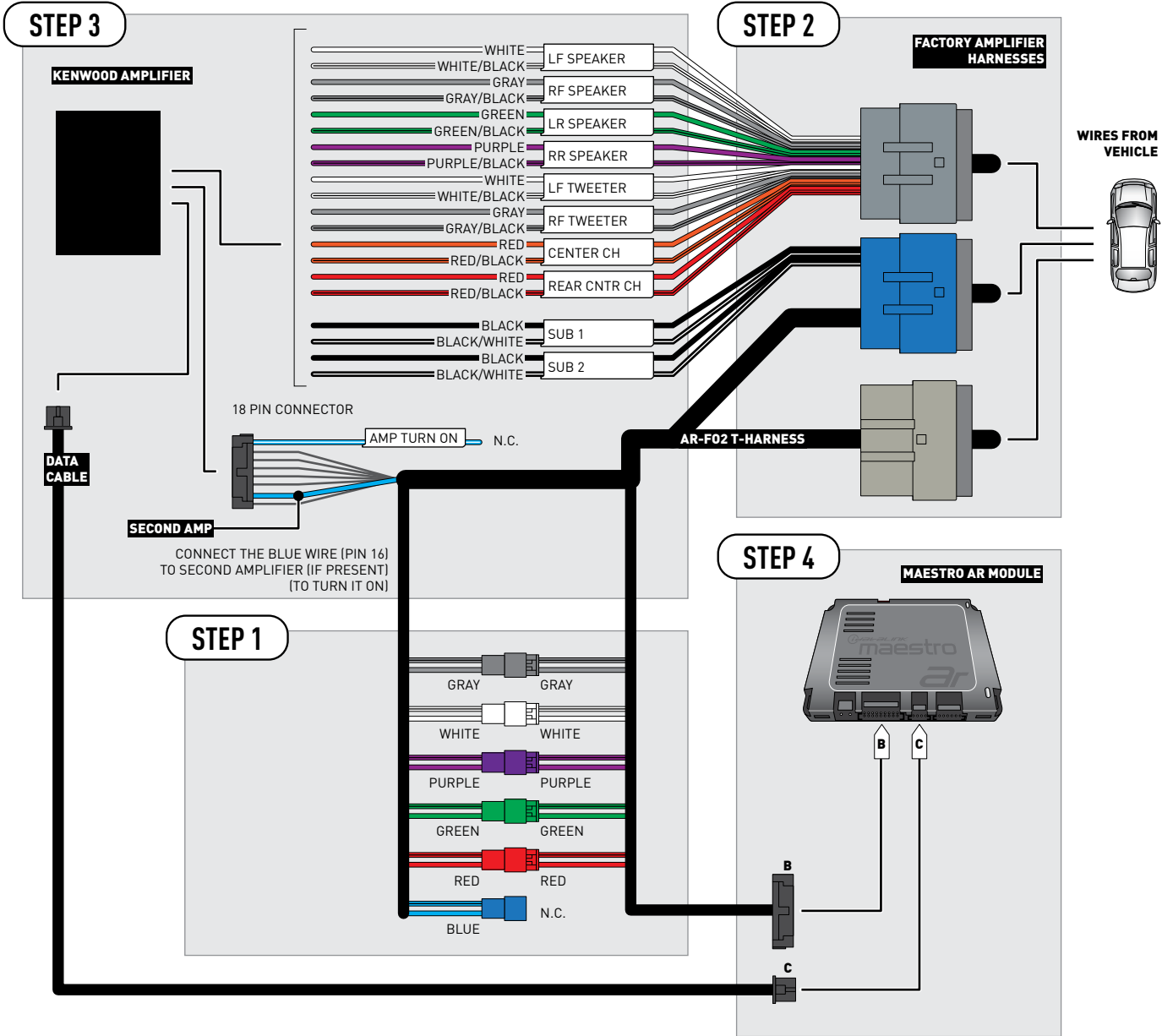

CONNECTION NOT REQUIRED

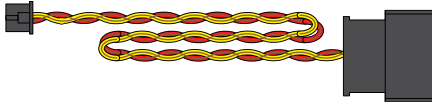

VEHICLE WIRE REFERENCE CHART

T-Harness Wires		Vehicle Wires	
Wire Tag	Wire Color	Speaker Wire Description	Component Position
LF SPEAKER	White	Left Front Speaker (+)	~
	White/Black	Left Front Speaker (-)	
LF TWEETER	White	Left Front Tweeter (+)	~
	White/Black	Left Front Tweeter (-)	
RF SPEAKER	Gray	Right Front Speaker (+)	~
	Gray/Black	Right Front Speaker (-)	
RF TWEETER	Gray	Right Front Tweeter (+)	~
	Gray/Black	Right Front Tweeter (-)	
LR SPEAKER	Green	Left Rear Speaker (+)	~
	Green/Black	Left Rear Speaker (-)	
RR SPEAKER	Purple	Right Rear Speaker (+)	~
	Purple/Black	Right Rear Speaker (-)	
REAR CNTR CH	Red	n/a	~
	Red/Black	n/a	
CENTER CH	Orange	Center Channel (+)	~
	Orange/Black	Center Channel (-)	
SUB 1	Black	Left Rear Subwoofer (+)	~
	Black/White	Left Rear Subwoofer (-)	
SUB 2	Black	Right Rear Subwoofer (+)	~
	Black/White	Right Rear Subwoofer (-)	

Note: The amplifier output colors and labels on the AR-F02 T-harness do not correspond to the vehicle. For vehicle specific wiring designation, follow this wiring chart.

Amplifier location

(2013-2014) : Under center console

(2015-2017 regular cab) : Base of left B-pillar

(2015-2017 Super cab/Crew cab) : Base of left C-pillar



INSTALL GUIDE FORD F250 2013-2018

ENABLE A SEAMLESS AFTERMARKET AMPLIFIER INSTALLATION,
WITHOUT CHANGING YOUR RADIO.



KENWOOD

PRODUCTS REQUIRED

iDatalink Maestro AR Amplifier Replacement Interface
iDatalink Maestro AR-FO2 Installation Harness

OPTIONAL ACCESSORIES

Extension harness provided with
Kenwood amplifier

PROGRAMMED FIRMWARE

ADS-AR-FOR02

NOTICE: Automotive Data Solutions Inc. (ADS) recommends having this installation performed by a certified technician. Logos and trademarks used here in are the properties of their respective owners.

WELCOME

Congratulations on the purchase of your iDatalink Maestro AR Amplifier replacement solution. You are now a few simple steps away from enjoying your new car amplifier.

Before starting your installation, please ensure that your iDatalink Maestro module is programmed with the correct firmware for your vehicle and that you carefully review the install guide.

TABLE OF CONTENTS

Settings and Features	3
Installation Instructions	4
Wiring Diagram	5
Vehicle Wire Reference Chart	6

NEED HELP?

 1 866 427-2999

 maestro.support@idatalink.com

 maestro.idatalink.com/support
www.12voltdata.com/forum

SETTINGS AND FEATURES

CHIME ADJUSTMENT

Chime volume adjustment will only work if the chimes are played by the vehicle speakers (some Ford vehicles generate the chime in the cluster or with dedicated speakers in the back of the vehicle).

CHIME ADJUSTMENT PROCEDURE:

- Set the audio source to OFF.
- Activate door or parking assist chime.
- Adjust the chime volume using the volume knob.

MAESTRO AR PROGRAMMABLE FEATURES

These tone control features can be adjusted in the settings of the radio.

FACTORY CONTROL FEATURES:

- Bass Tone Control
Subwoofer Volume
- Mid Tone Control
Not applicable
- Treble Tone Control
Tweeter Output Gain
- Surround Control
Not applicable
- Speed Compensated Volume
None

INSTALLATION INSTRUCTIONS

STEP 1

- Remove the factory amplifier (refer to wire chart for amplifier location).
- Configure the 2 pin connectors on the AR-F02 T-harness as shown on the wiring diagram.

STEP 2

- Connect the factory amplifier harnesses to the AR-F02 T-harness.

STEP 3

- Connect the wires from the AR-F02 T-harness to the aftermarket amplifier.

Note 1:

If you are running your own speaker wires from the amplifier to the speakers, this step is not necessary.

Note 2:

The amplifier output colors and labels on the F02 T-harness do not correspond to the vehicle. For vehicle specific wiring designation, see the wiring chart.

- Plug the connector from the AR-F02 T-Harness into the aftermarket amplifier.
- Plug the Data cable to the data port of the aftermarket amplifier.

STEP 4

- Connect all the harnesses to the Maestro AR module.

Note 3:

The aftermarket amplifier will not turn OFF with the key, it will shut down when the vehicle goes to sleep.

Note 4:

There will no longer be any audible beeps from the OEM radio when using the radio menus.

- For technical assistance call 1-866-427-2999 or e-mail "maestro.support@idatalink.com". Visit us at "maestro.idatalink.com/support" and "www.12voltdata.com/forum/"

WIRING DIAGRAM

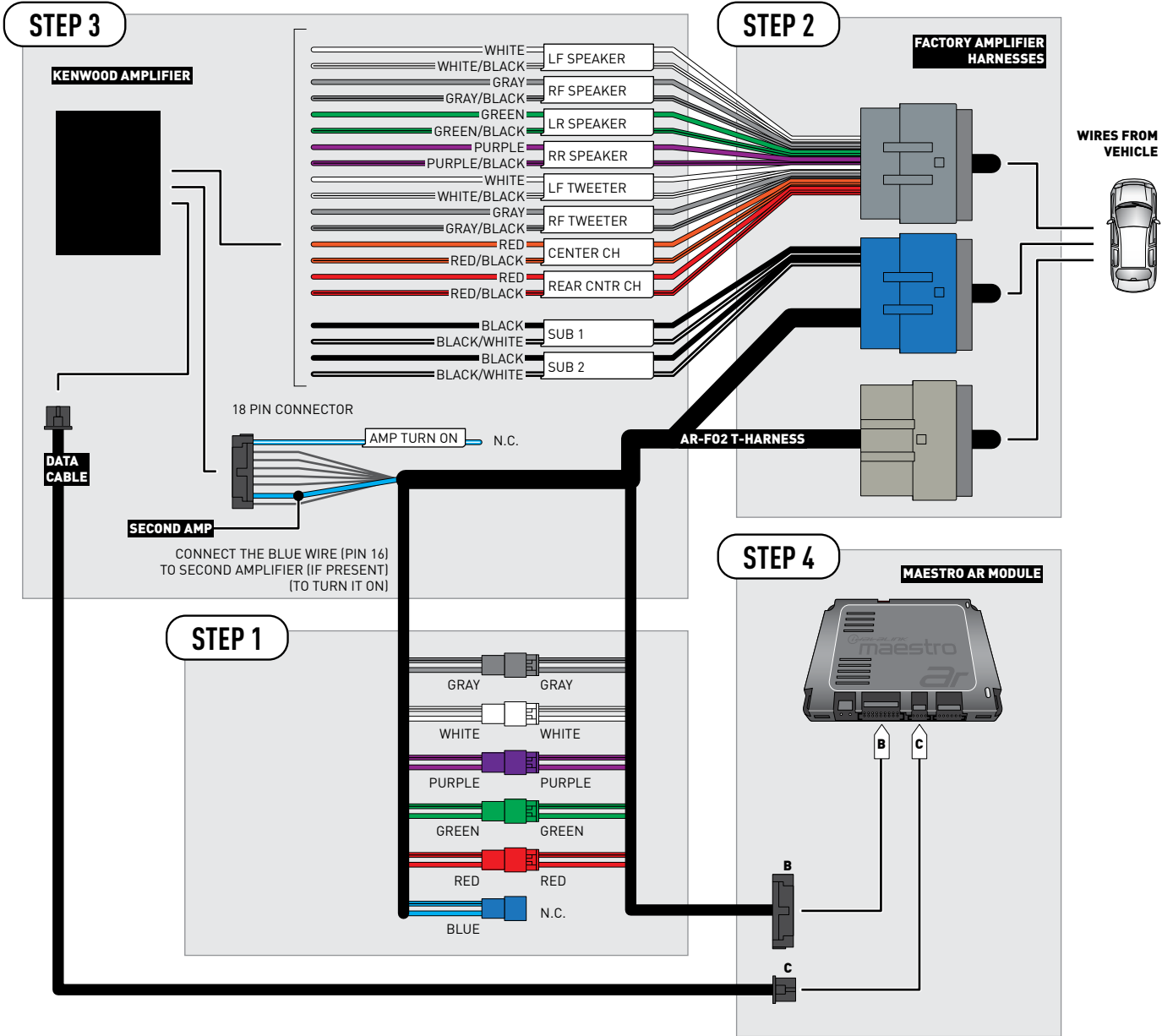

CONNECTION NOT REQUIRED

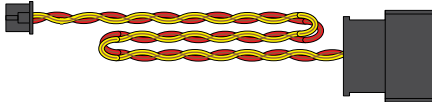

VEHICLE WIRE REFERENCE CHART

T-Harness Wires		Vehicle Wires	
Wire Tag	Wire Color	Speaker Wire Description	Component Position
LF SPEAKER	White	Left Front Speaker (+)	~
	White/Black	Left Front Speaker (-)	
LF TWEETER	White	Left Front Tweeter (+)	~
	White/Black	Left Front Tweeter (-)	
RF SPEAKER	Gray	Right Front Speaker (+)	~
	Gray/Black	Right Front Speaker (-)	
RF TWEETER	Gray	Right Front Tweeter (+)	~
	Gray/Black	Right Front Tweeter (-)	
LR SPEAKER	Green	Left Rear Speaker (+)	~
	Green/Black	Left Rear Speaker (-)	
RR SPEAKER	Purple	Right Rear Speaker (+)	~
	Purple/Black	Right Rear Speaker (-)	
REAR CNTR CH	Red	n/a	~
	Red/Black	n/a	
CENTER CH	Orange	Center Channel (+)	~
	Orange/Black	Center Channel (-)	
SUB 1	Black	Left Rear Subwoofer (+)	~
	Black/White	Left Rear Subwoofer (-)	
SUB 2	Black	Right Rear Subwoofer (+)	~
	Black/White	Right Rear Subwoofer (-)	

Note: The amplifier output colors and labels on the AR-F02 T-harness do not correspond to the vehicle. For vehicle specific wiring designation, follow this wiring chart.

Amplifier location

Crew cab : Base of left C-pillar

Super cab : Rear center of floor



INSTALL GUIDE FORD F250 2019

ENABLE A SEAMLESS AFTERMARKET AMPLIFIER INSTALLATION,
WITHOUT CHANGING YOUR RADIO.



KENWOOD

PRODUCTS REQUIRED

iDatalink Maestro AR Amplifier Replacement Interface
iDatalink Maestro AR-F02 Installation Harness

OPTIONAL ACCESSORIES

Extension harness provided with
Kenwood amplifier

PROGRAMMED FIRMWARE

ADS-AR-FOR02

NOTICE: Automotive Data Solutions Inc. (ADS) recommends having this installation performed by a certified technician. Logos and trademarks used here in are the properties of their respective owners.

WELCOME

Congratulations on the purchase of your iDatalink Maestro AR Amplifier replacement solution. You are now a few simple steps away from enjoying your new car amplifier.

Before starting your installation, please ensure that your iDatalink Maestro module is programmed with the correct firmware for your vehicle and that you carefully review the install guide.

NEED HELP?

 1 866 427-2999

 maestro.support@idatalink.com

 maestro.idatalink.com/support
www.12voltdata.com/forum

TABLE OF CONTENTS

Settings and Features	3
Installation Instructions	4
Wiring Diagram	5
Vehicle Wire Reference Chart	6

SETTINGS AND FEATURES

CHIME ADJUSTMENT

Chime volume adjustment will only work if the chimes are played by the vehicle speakers (some Ford vehicles generate the chime in the cluster or with dedicated speakers in the back of the vehicle).

CHIME ADJUSTMENT PROCEDURE:

- Set the audio source to OFF.
- Activate door or parking assist chime.
- Adjust the chime volume using the volume knob.

MAESTRO AR PROGRAMMABLE FEATURES

These tone control features can be adjusted in the settings of the radio.

FACTORY CONTROL FEATURES:

- Bass Tone Control
 - Subwoofer Volume**
- Mid Tone Control
 - Not applicable
- Treble Tone Control
 - Tweeter Output Gain**
- Surround Control
 - Not applicable
- Speed Compensated Volume
 - None**

INSTALLATION INSTRUCTIONS

- Determine if your vehicle is equipped with one or multiple amplifiers to refer to the appropriate wiring diagram.

STEP 1

- Remove the factory amplifier (refer to wire chart for amplifier location).
- Configure the 2 pin connectors on the AR-F02 T-harness as shown on the wiring diagram.

STEP 2

- Cut and isolate Yellow wire (pin 5) and Black wire (pin 16) of the blue connector of the aF02 T-Harness.
- Connect the factory amplifier harnesses to the AR-F02 T-harness.

STEP 3

- Connect the wires from the AR-F02 T-harness to the aftermarket amplifier.

Note 1:

If you are running your own speaker wires from the amplifier to the speakers, this step is not necessary.

Note 2:

The amplifier output colors and labels on the F02 T-harness do not correspond to the vehicle. For vehicle specific wiring designation, see the wiring chart.

- Plug the connector from the AR-F02 T-Harness into the aftermarket amplifier.
- Plug the Data cable to the data port of the aftermarket amplifier.

STEP 4

- Connect all the harnesses to the Maestro AR module.

Note 3:

The aftermarket amplifier will not turn OFF with the key, it will shut down when the vehicle goes to sleep.

Note 4:

There will no longer be any audible beeps from the OEM radio when using the radio menus.

- For technical assistance call 1-866-427-2999 or e-mail "maestro.support@idatalink.com". Visit us at "maestro.idatalink.com/support" and "www.12voltdata.com/forum/"

WIRING DIAGRAM

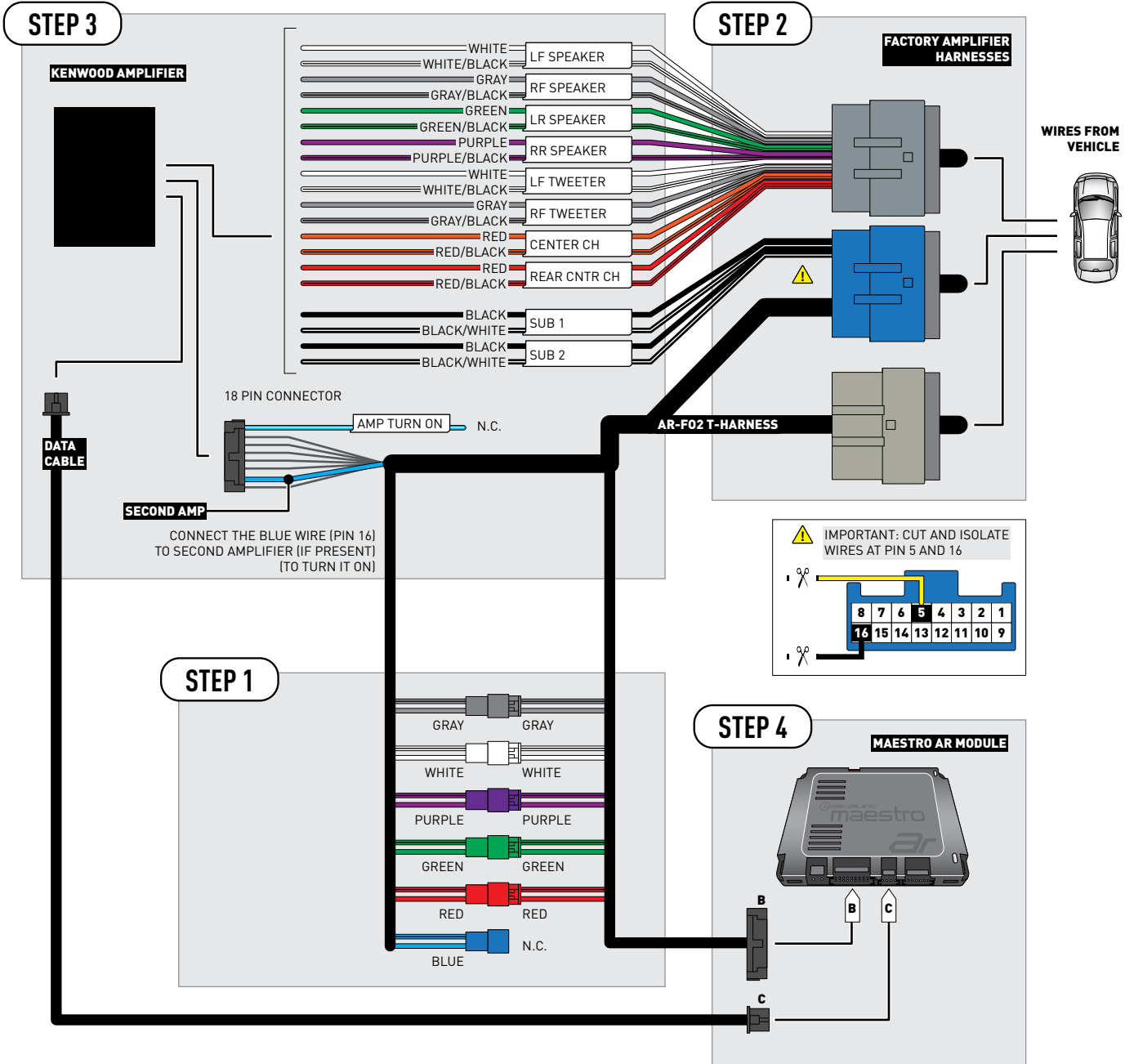

CONNECTION NOT REQUIRED

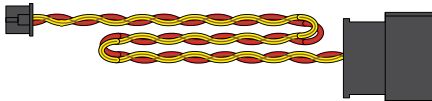

VEHICLE WIRE REFERENCE CHART

T-Harness Wires		Vehicle Wires	
Wire Tag	Wire Color	Speaker Wire Description	Component Position
LF SPEAKER	White	Left Front Speaker (+)	~
	White/Black	Left Front Speaker (-)	
LF TWEETER	White	Left Front Tweeter (+)	~
	White/Black	Left Front Tweeter (-)	
RF SPEAKER	Gray	Right Front Speaker (+)	~
	Gray/Black	Right Front Speaker (-)	
RF TWEETER	Gray	Right Front Tweeter (+)	~
	Gray/Black	Right Front Tweeter (-)	
LR SPEAKER	Green	Left Rear Speaker (+)	~
	Green/Black	Left Rear Speaker (-)	
RR SPEAKER	Purple	Right Rear Speaker (+)	~
	Purple/Black	Right Rear Speaker (-)	
REAR CNTR CH	Red	n/a	~
	Red/Black	n/a	
CENTER CH	Orange	Center Channel (+)	~
	Orange/Black	Center Channel (-)	
SUB 1	Black	Left Rear Subwoofer (+)	~
	Black/White	Left Rear Subwoofer (-)	
SUB 2	Black	Right Rear Subwoofer (+)	~
	Black/White	Right Rear Subwoofer (-)	

Note: The amplifier output colors and labels on the AR-F02 T-harness do not correspond to the vehicle. For vehicle specific wiring designation, follow this wiring chart.

Amplifier location

Crew cab : Base of left C-pillar

Super cab : Rear center of floor



INSTALL GUIDE FORD F350 2013-2018

ENABLE A SEAMLESS AFTERMARKET AMPLIFIER INSTALLATION,
WITHOUT CHANGING YOUR RADIO.



KENWOOD

PRODUCTS REQUIRED

iDatalink Maestro AR Amplifier Replacement Interface
iDatalink Maestro AR-F02 Installation Harness

OPTIONAL ACCESSORIES

Extension harness provided with
Kenwood amplifier

PROGRAMMED FIRMWARE

ADS-AR-FOR02

NOTICE: Automotive Data Solutions Inc. (ADS) recommends having this installation performed by a certified technician. Logos and trademarks used here in are the properties of their respective owners.

WELCOME

Congratulations on the purchase of your iDatalink Maestro AR Amplifier replacement solution. You are now a few simple steps away from enjoying your new car amplifier.

Before starting your installation, please ensure that your iDatalink Maestro module is programmed with the correct firmware for your vehicle and that you carefully review the install guide.

TABLE OF CONTENTS

Settings and Features	3
Installation Instructions	4
Wiring Diagram	5
Vehicle Wire Reference Chart	6

NEED HELP?

 1 866 427-2999

 maestro.support@idatalink.com

 maestro.idatalink.com/support
www.12voltdata.com/forum

SETTINGS AND FEATURES

CHIME ADJUSTMENT

Chime volume adjustment will only work if the chimes are played by the vehicle speakers (some Ford vehicles generate the chime in the cluster or with dedicated speakers in the back of the vehicle).

CHIME ADJUSTMENT PROCEDURE:

- Set the audio source to OFF.
- Activate door or parking assist chime.
- Adjust the chime volume using the volume knob.

MAESTRO AR PROGRAMMABLE FEATURES

These tone control features can be adjusted in the settings of the radio.

FACTORY CONTROL FEATURES:

- Bass Tone Control
Subwoofer Volume
- Mid Tone Control
Not applicable
- Treble Tone Control
Tweeter Output Gain
- Surround Control
Not applicable
- Speed Compensated Volume
None

INSTALLATION INSTRUCTIONS

STEP 1

- Remove the factory amplifier (refer to wire chart for amplifier location).
- Configure the 2 pin connectors on the AR-F02 T-harness as shown on the wiring diagram.

STEP 2

- Connect the factory amplifier harnesses to the AR-F02 T-harness.

STEP 3

- Connect the wires from the AR-F02 T-harness to the aftermarket amplifier.

Note 1:

If you are running your own speaker wires from the amplifier to the speakers, this step is not necessary.

Note 2:

The amplifier output colors and labels on the F02 T-harness do not correspond to the vehicle. For vehicle specific wiring designation, see the wiring chart.

- Plug the connector from the AR-F02 T-Harness into the aftermarket amplifier.
- Plug the Data cable to the data port of the aftermarket amplifier.

STEP 4

- Connect all the harnesses to the Maestro AR module.

Note 3:

The aftermarket amplifier will not turn OFF with the key, it will shut down when the vehicle goes to sleep.

Note 4:

There will no longer be any audible beeps from the OEM radio when using the radio menus.

- For technical assistance call 1-866-427-2999 or e-mail "maestro.support@idatalink.com". Visit us at "maestro.idatalink.com/support" and "www.12voltdata.com/forum/"

WIRING DIAGRAM

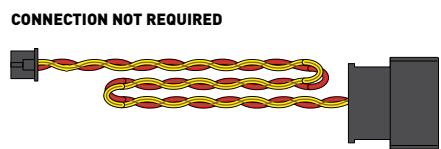
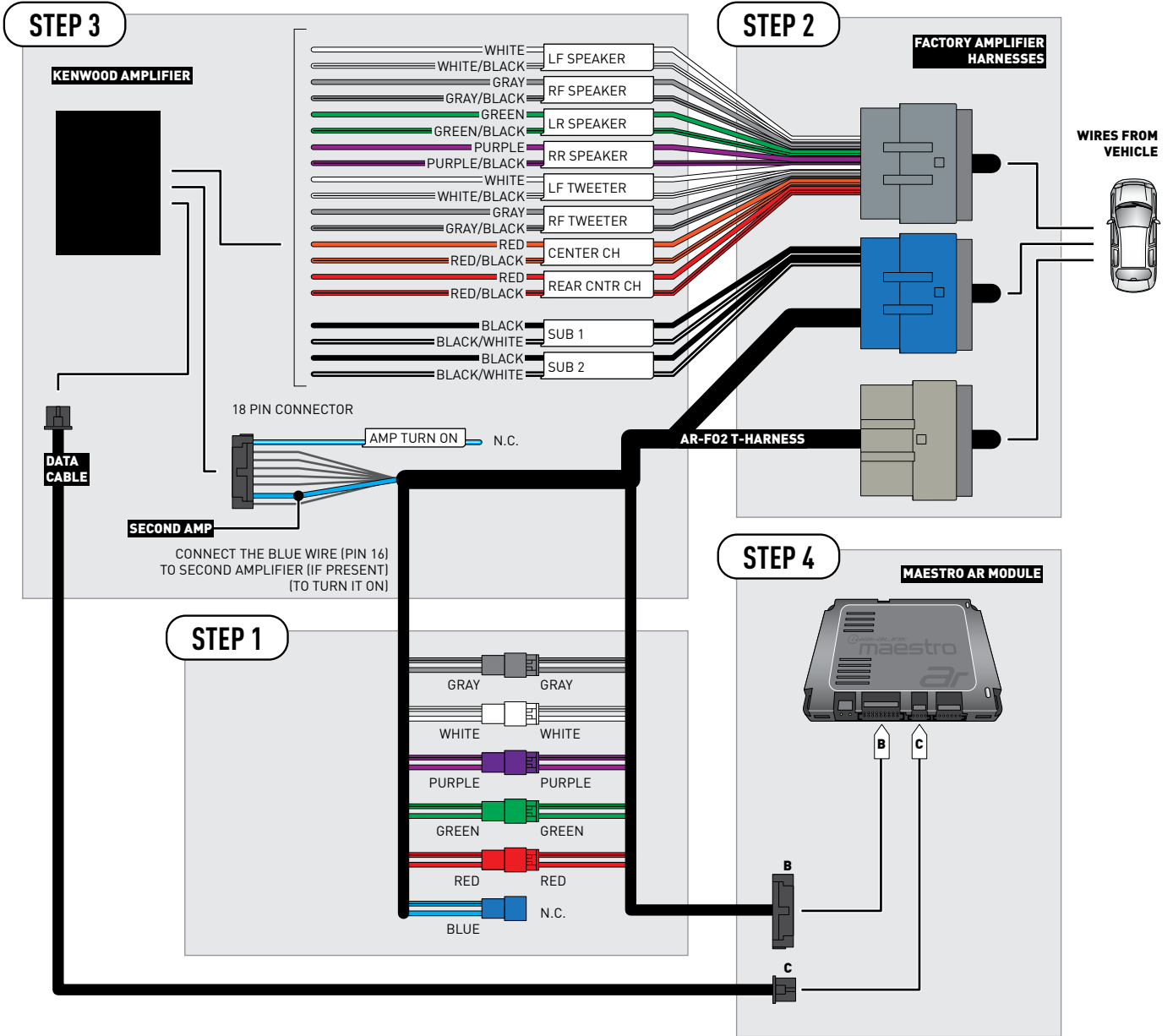

VEHICLE WIRE REFERENCE CHART

T-Harness Wires		Vehicle Wires	
Wire Tag	Wire Color	Speaker Wire Description	Component Position
LF SPEAKER	White	Left Front Speaker (+)	~
	White/Black	Left Front Speaker (-)	
LF TWEETER	White	Left Front Tweeter (+)	~
	White/Black	Left Front Tweeter (-)	
RF SPEAKER	Gray	Right Front Speaker (+)	~
	Gray/Black	Right Front Speaker (-)	
RF TWEETER	Gray	Right Front Tweeter (+)	~
	Gray/Black	Right Front Tweeter (-)	
LR SPEAKER	Green	Left Rear Speaker (+)	~
	Green/Black	Left Rear Speaker (-)	
RR SPEAKER	Purple	Right Rear Speaker (+)	~
	Purple/Black	Right Rear Speaker (-)	
REAR CNTR CH	Red	n/a	~
	Red/Black	n/a	
CENTER CH	Orange	Center Channel (+)	~
	Orange/Black	Center Channel (-)	
SUB 1	Black	Left Rear Subwoofer (+)	~
	Black/White	Left Rear Subwoofer (-)	
SUB 2	Black	Right Rear Subwoofer (+)	~
	Black/White	Right Rear Subwoofer (-)	

Note: The amplifier output colors and labels on the AR-F02 T-harness do not correspond to the vehicle. For vehicle specific wiring designation, follow this wiring chart.

Amplifier location

Crew cab : Base of left C-pillar

Super cab : Rear center of floor



INSTALL GUIDE FORD F350 2019

ENABLE A SEAMLESS AFTERMARKET AMPLIFIER INSTALLATION,
WITHOUT CHANGING YOUR RADIO.



KENWOOD

PRODUCTS REQUIRED

iDatalink Maestro AR Amplifier Replacement Interface
iDatalink Maestro AR-F02 Installation Harness

OPTIONAL ACCESSORIES

Extension harness provided with
Kenwood amplifier

PROGRAMMED FIRMWARE

ADS-AR-FOR02

NOTICE: Automotive Data Solutions Inc. (ADS) recommends having this installation performed by a certified technician. Logos and trademarks used here in are the properties of their respective owners.

WELCOME

Congratulations on the purchase of your iDatalink Maestro AR Amplifier replacement solution. You are now a few simple steps away from enjoying your new car amplifier.

Before starting your installation, please ensure that your iDatalink Maestro module is programmed with the correct firmware for your vehicle and that you carefully review the install guide.

NEED HELP?

 1 866 427-2999

 maestro.support@idatalink.com

 maestro.idatalink.com/support
www.12voltdata.com/forum

TABLE OF CONTENTS

Settings and Features	3
Installation Instructions	4
Wiring Diagram	5
Vehicle Wire Reference Chart	6

SETTINGS AND FEATURES

CHIME ADJUSTMENT

Chime volume adjustment will only work if the chimes are played by the vehicle speakers (some Ford vehicles generate the chime in the cluster or with dedicated speakers in the back of the vehicle).

CHIME ADJUSTMENT PROCEDURE:

- Set the audio source to OFF.
- Activate door or parking assist chime.
- Adjust the chime volume using the volume knob.

MAESTRO AR PROGRAMMABLE FEATURES

These tone control features can be adjusted in the settings of the radio.

FACTORY CONTROL FEATURES:

- Bass Tone Control
Subwoofer Volume
- Mid Tone Control
Not applicable
- Treble Tone Control
Tweeter Output Gain
- Surround Control
Not applicable
- Speed Compensated Volume
None

INSTALLATION INSTRUCTIONS

- Determine if your vehicle is equipped with one or multiple amplifiers to refer to the appropriate wiring diagram.

STEP 1

- Remove the factory amplifier (refer to wire chart for amplifier location).
- Configure the 2 pin connectors on the AR-F02 T-harness as shown on the wiring diagram.

STEP 2

- Cut and isolate Yellow wire (pin 5) and Black wire (pin 16) of the blue connector of the aF02 T-Harness.
- Connect the factory amplifier harnesses to the AR-F02 T-harness.

STEP 3

- Connect the wires from the AR-F02 T-harness to the aftermarket amplifier.

Note 1:

If you are running your own speaker wires from the amplifier to the speakers, this step is not necessary.

Note 2:

The amplifier output colors and labels on the F02 T-harness do not correspond to the vehicle. For vehicle specific wiring designation, see the wiring chart.

- Plug the connector from the AR-F02 T-Harness into the aftermarket amplifier.
- Plug the Data cable to the data port of the aftermarket amplifier.

STEP 4

- Connect all the harnesses to the Maestro AR module.

Note 3:

The aftermarket amplifier will not turn OFF with the key, it will shut down when the vehicle goes to sleep.

Note 4:

There will no longer be any audible beeps from the OEM radio when using the radio menus.

- For technical assistance call 1-866-427-2999 or e-mail "maestro.support@idatalink.com". Visit us at "maestro.idatalink.com/support" and "www.12voltdata.com/forum/"

WIRING DIAGRAM

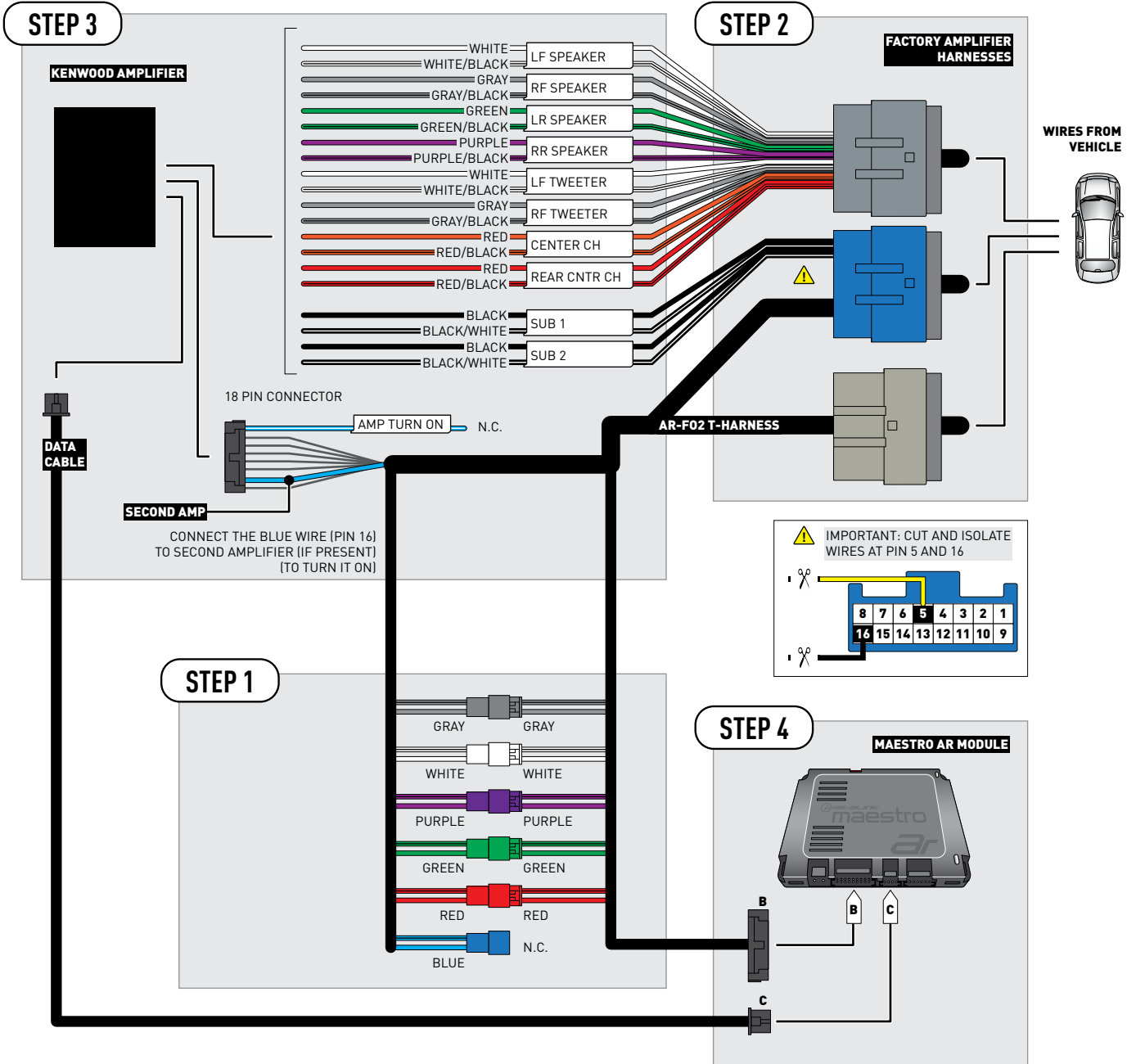

CONNECTION NOT REQUIRED

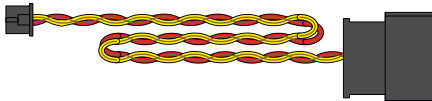

VEHICLE WIRE REFERENCE CHART

T-Harness Wires		Vehicle Wires	
Wire Tag	Wire Color	Speaker Wire Description	Component Position
LF SPEAKER	White	Left Front Speaker (+)	~
	White/Black	Left Front Speaker (-)	
LF TWEETER	White	Left Front Tweeter (+)	~
	White/Black	Left Front Tweeter (-)	
RF SPEAKER	Gray	Right Front Speaker (+)	~
	Gray/Black	Right Front Speaker (-)	
RF TWEETER	Gray	Right Front Tweeter (+)	~
	Gray/Black	Right Front Tweeter (-)	
LR SPEAKER	Green	Left Rear Speaker (+)	~
	Green/Black	Left Rear Speaker (-)	
RR SPEAKER	Purple	Right Rear Speaker (+)	~
	Purple/Black	Right Rear Speaker (-)	
REAR CNTR CH	Red	n/a	~
	Red/Black	n/a	
CENTER CH	Orange	Center Channel (+)	~
	Orange/Black	Center Channel (-)	
SUB 1	Black	Left Rear Subwoofer (+)	~
	Black/White	Left Rear Subwoofer (-)	
SUB 2	Black	Right Rear Subwoofer (+)	~
	Black/White	Right Rear Subwoofer (-)	

Note: The amplifier output colors and labels on the AR-F02 T-harness do not correspond to the vehicle. For vehicle specific wiring designation, follow this wiring chart.

Amplifier location

Crew cab : Base of left C-pillar

Super cab : Rear center of floor



INSTALL GUIDE FORD FLEX 2013-2018

ENABLE A SEAMLESS AFTERMARKET AMPLIFIER INSTALLATION,
WITHOUT CHANGING YOUR RADIO.



KENWOOD

PRODUCTS REQUIRED

iDatalink Maestro AR Amplifier Replacement Interface
iDatalink Maestro AR-F02 Installation Harness

OPTIONAL ACCESSORIES

Extension harness provided with
Kenwood amplifier

PROGRAMMED FIRMWARE

ADS-AR-FOR02

NOTICE: Automotive Data Solutions Inc. (ADS) recommends having this installation performed by a certified technician. Logos and trademarks used here in are the properties of their respective owners.

WELCOME

Congratulations on the purchase of your iDatalink Maestro AR Amplifier replacement solution. You are now a few simple steps away from enjoying your new car amplifier.

Before starting your installation, please ensure that your iDatalink Maestro module is programmed with the correct firmware for your vehicle and that you carefully review the install guide.

TABLE OF CONTENTS

Settings and Features	3
Installation Instructions	4
Wiring Diagram	5
Vehicle Wire Reference Chart	6

NEED HELP?

 1 866 427-2999

 maestro.support@idatalink.com

 maestro.idatalink.com/support
www.12voltdata.com/forum

SETTINGS AND FEATURES

CHIME ADJUSTMENT

Chime volume adjustment will only work if the chimes are played by the vehicle speakers (some Ford vehicles generate the chime in the cluster or with dedicated speakers in the back of the vehicle).

CHIME ADJUSTMENT PROCEDURE:

- Set the audio source to OFF.
- Activate door or parking assist chime.
- Adjust the chime volume using the volume knob.

MAESTRO AR PROGRAMMABLE FEATURES

These tone control features can be adjusted in the settings of the radio.

FACTORY CONTROL FEATURES:

- Bass Tone Control
Subwoofer Volume
- Mid Tone Control
Not applicable
- Treble Tone Control
Tweeter Output Gain
- Surround Control
Not applicable
- Speed Compensated Volume
None

INSTALLATION INSTRUCTIONS

STEP 1

- Remove the factory amplifier (refer to wire chart for amplifier location).
- Configure the 2 pin connectors on the AR-F02 T-harness as shown on the wiring diagram.

STEP 2

- Connect the factory amplifier harnesses to the AR-F02 T-harness.

STEP 3

- Connect the wires from the AR-F02 T-harness to the aftermarket amplifier.

Note 1:

If you are running your own speaker wires from the amplifier to the speakers, this step is not necessary.

Note 2:

The amplifier output colors and labels on the F02 T-harness do not correspond to the vehicle. For vehicle specific wiring designation, see the wiring chart.

- Plug the connector from the AR-F02 T-Harness into the aftermarket amplifier.
- Plug the Data cable to the data port of the aftermarket amplifier.

STEP 4

- Connect all the harnesses to the Maestro AR module.

Note 3:

The aftermarket amplifier will not turn OFF with the key, it will shut down when the vehicle goes to sleep.

Note 4:

There will no longer be any audible beeps from the OEM radio when using the radio menus.

- For technical assistance call 1-866-427-2999 or e-mail "maestro.support@idatalink.com". Visit us at "maestro.idatalink.com/support" and "www.12voltdata.com/forum/"

WIRING DIAGRAM

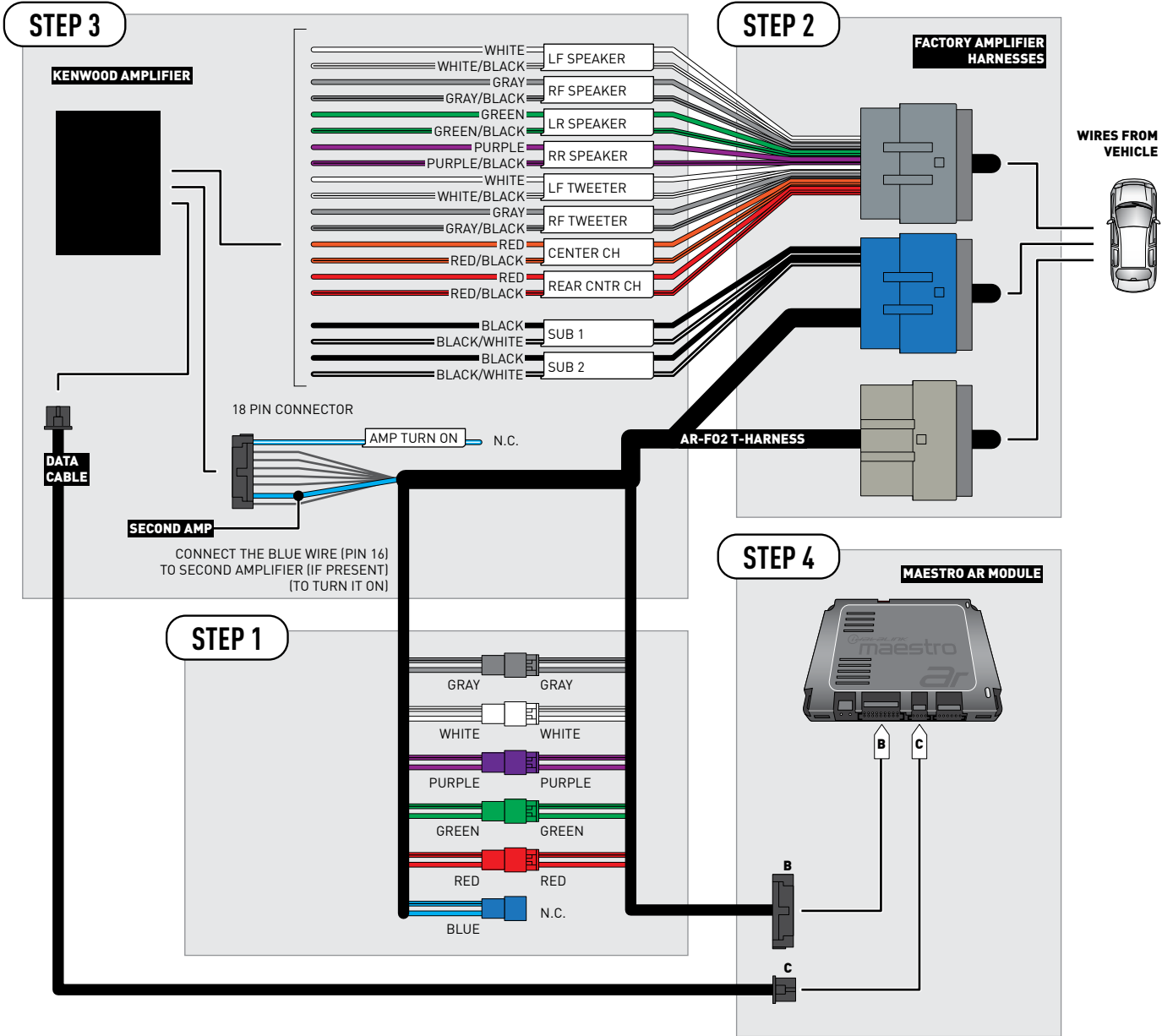

CONNECTION NOT REQUIRED

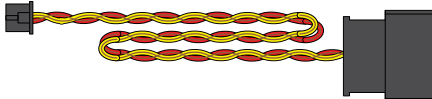

VEHICLE WIRE REFERENCE CHART

T-Harness Wires		Vehicle Wires	
Wire Tag	Wire Color	Speaker Wire Description	Component Position
LF SPEAKER	White	Left Front Speaker (+)	~
	White/Black	Left Front Speaker (-)	
LF TWEETER	White	Left Front Tweeter (+)	~
	White/Black	Left Front Tweeter (-)	
RF SPEAKER	Gray	Right Front Speaker (+)	~
	Gray/Black	Right Front Speaker (-)	
RF TWEETER	Gray	Right Front Tweeter (+)	~
	Gray/Black	Right Front Tweeter (-)	
LR SPEAKER	Green	Left Rear Speaker (+)	~
	Green/Black	Left Rear Speaker (-)	
RR SPEAKER	Purple	Right Rear Speaker (+)	~
	Purple/Black	Right Rear Speaker (-)	
REAR CNTR CH	Red	Rear Center Channel (+)	~
	Red/Black	Rear Center Channel (-)	
CENTER CH	Orange	Front Center Channel (+)	~
	Orange/Black	Front Center Channel (-)	
SUB 1	Black	Left Rear Subwoofer (+)	~
	Black/White	Left Rear Subwoofer (-)	
SUB 2	Black	Right Rear Subwoofer (+)	~
	Black/White	Right Rear Subwoofer (-)	

Note: The amplifier output colors and labels on the AR-F02 T-harness do not correspond to the vehicle. For vehicle specific wiring designation, follow this wiring chart.

Amplifier location

Behind right rear quarter panel



INSTALL GUIDE FORD FOCUS 2012-2018

ENABLE A SEAMLESS AFTERMARKET AMPLIFIER INSTALLATION,
WITHOUT CHANGING YOUR RADIO.



KENWOOD

PRODUCTS REQUIRED

iDatalink Maestro AR Amplifier Replacement Interface
iDatalink Maestro AR-F02 Installation Harness

OPTIONAL ACCESSORIES

Extension harness provided with
Kenwood amplifier

PROGRAMMED FIRMWARE

ADS-AR-FOR02

NOTICE: Automotive Data Solutions Inc. (ADS) recommends having this installation performed by a certified technician. Logos and trademarks used here in are the properties of their respective owners.

WELCOME

Congratulations on the purchase of your iDatalink Maestro AR Amplifier replacement solution. You are now a few simple steps away from enjoying your new car amplifier.

Before starting your installation, please ensure that your iDatalink Maestro module is programmed with the correct firmware for your vehicle and that you carefully review the install guide.

TABLE OF CONTENTS

Settings and Features	3
Installation Instructions	4
Wiring Diagram	5
Vehicle Wire Reference Chart	6

NEED HELP?

 1 866 427-2999

 maestro.support@idatalink.com

 maestro.idatalink.com/support
www.12voltdata.com/forum

SETTINGS AND FEATURES

CHIME ADJUSTMENT

Chime volume adjustment will only work if the chimes are played by the vehicle speakers (some Ford vehicles generate the chime in the cluster or with dedicated speakers in the back of the vehicle).

CHIME ADJUSTMENT PROCEDURE:

- Set the audio source to OFF.
- Activate door or parking assist chime.
- Adjust the chime volume using the volume knob.

MAESTRO AR PROGRAMMABLE FEATURES

These tone control features can be adjusted in the settings of the radio.

FACTORY CONTROL FEATURES:

- Bass Tone Control
Subwoofer Volume
- Mid Tone Control
Not applicable
- Treble Tone Control
Tweeter Output Gain
- Surround Control
Not applicable
- Speed Compensated Volume
None

INSTALLATION INSTRUCTIONS

STEP 1

- Remove the factory amplifier (refer to wire chart for amplifier location).
- Configure the 2 pin connectors on the AR-F02 T-harness as shown on the wiring diagram.

STEP 2

- Connect the factory amplifier harnesses to the AR-F02 T-harness.

STEP 3

- Connect the wires from the AR-F02 T-harness to the aftermarket amplifier.

Note 1:

If you are running your own speaker wires from the amplifier to the speakers, this step is not necessary.

Note 2:

The amplifier output colors and labels on the F02 T-harness do not correspond to the vehicle. For vehicle specific wiring designation, see the wiring chart.

- Plug the connector from the AR-F02 T-Harness into the aftermarket amplifier.
- Plug the Data cable to the data port of the aftermarket amplifier.

STEP 4

- Connect all the harnesses to the Maestro AR module.

Note 3:

The aftermarket amplifier will not turn OFF with the key, it will shut down when the vehicle goes to sleep.

Note 4:

There will no longer be any audible beeps from the OEM radio when using the radio menus.

- For technical assistance call 1-866-427-2999 or e-mail "maestro.support@idatalink.com". Visit us at "maestro.idatalink.com/support" and "www.12voltdata.com/forum/"

WIRING DIAGRAM

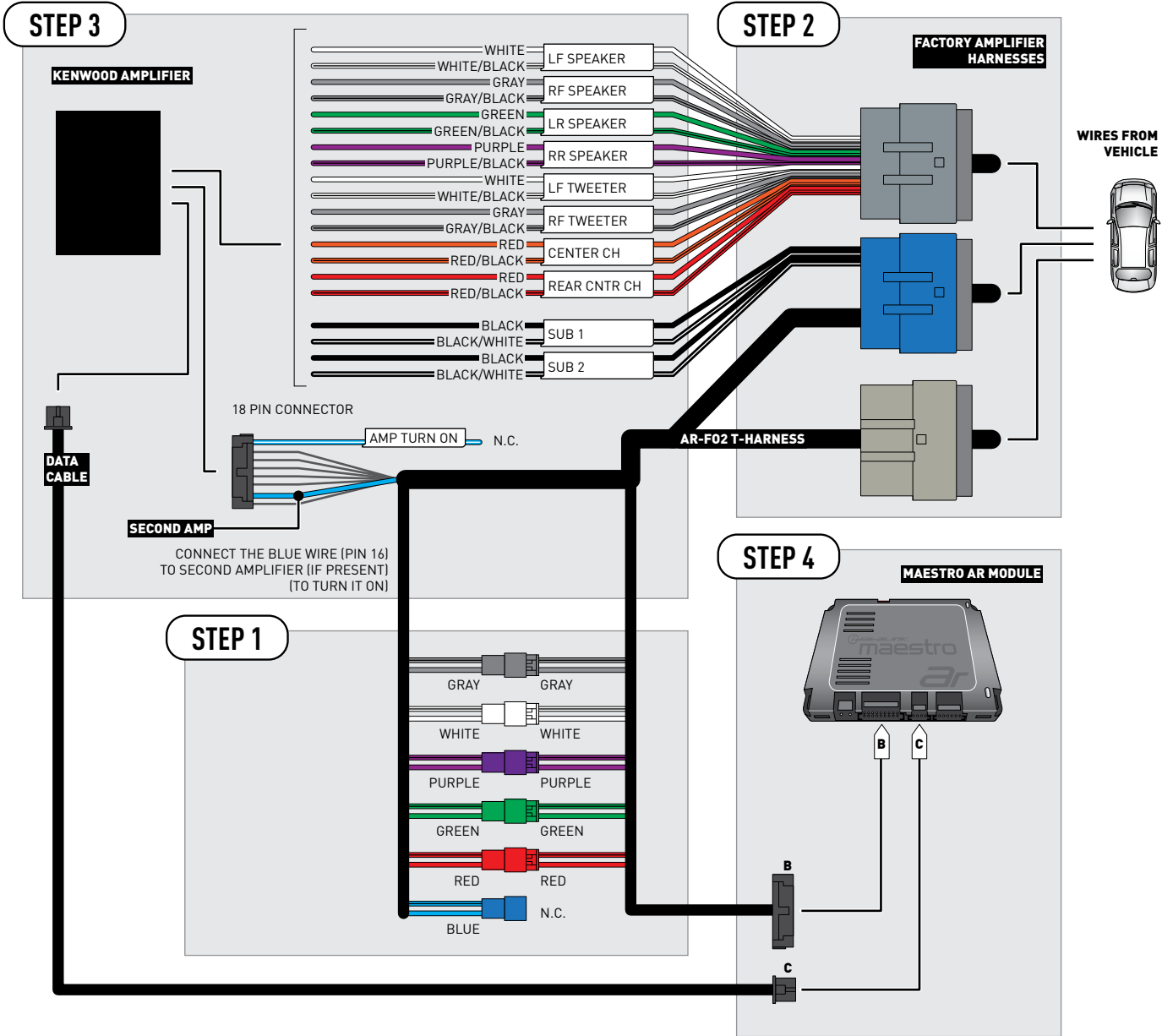

CONNECTION NOT REQUIRED

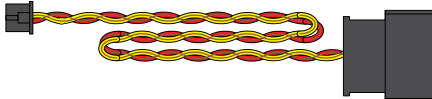

VEHICLE WIRE REFERENCE CHART

T-Harness Wires		Vehicle Wires	
Wire Tag	Wire Color	Speaker Wire Description	Component Position
LF SPEAKER	White	Left Front Speaker (+)	~
	White/Black	Left Front Speaker (-)	
LF TWEETER	White	Left Front Tweeter (+)	~
	White/Black	Left Front Tweeter (-)	
RF SPEAKER	Gray	Right Front Speaker (+)	~
	Gray/Black	Right Front Speaker (-)	
RF TWEETER	Gray	Right Front Tweeter (+)	~
	Gray/Black	Right Front Tweeter (-)	
LR SPEAKER	Green	Left Rear Speaker (+)	~
	Green/Black	Left Rear Speaker (-)	
RR SPEAKER	Purple	Right Rear Speaker (+)	~
	Purple/Black	Right Rear Speaker (-)	
REAR CNTR CH	Red	n/a	~
	Red/Black	n/a	
CENTER CH	Orange	Center Channel (+)	~
	Orange/Black	Center Channel (-)	
SUB 1	Black	Left Rear Subwoofer (+)	~
	Black/White	Left Rear Subwoofer (-)	
SUB 2	Black	Right Rear Subwoofer (+)	~
	Black/White	Right Rear Subwoofer (-)	

Note: The amplifier output colors and labels on the AR-F02 T-harness do not correspond to the vehicle. For vehicle specific wiring designation, follow this wiring chart.

Amplifier location

Left front of luggage compartment



INSTALL GUIDE FORD FUSION 2013-2016

ENABLE A SEAMLESS AFTERMARKET AMPLIFIER INSTALLATION,
WITHOUT CHANGING YOUR RADIO.



KENWOOD

PRODUCTS REQUIRED

iDatalink Maestro AR Amplifier Replacement Interface
iDatalink Maestro AR-F02 Installation Harness

OPTIONAL ACCESSORIES

Extension harness provided with
Kenwood amplifier

PROGRAMMED FIRMWARE

ADS-AR-FOR02

NOTICE: Automotive Data Solutions Inc. (ADS) recommends having this installation performed by a certified technician. Logos and trademarks used here in are the properties of their respective owners.

WELCOME

Congratulations on the purchase of your iDatalink Maestro AR Amplifier replacement solution. You are now a few simple steps away from enjoying your new car amplifier.

Before starting your installation, please ensure that your iDatalink Maestro module is programmed with the correct firmware for your vehicle and that you carefully review the install guide.

TABLE OF CONTENTS

Settings and Features	3
Installation Instructions	4
Wiring Diagram	5
Vehicle Wire Reference Chart	6

NEED HELP?

 1 866 427-2999

 maestro.support@idatalink.com

 maestro.idatalink.com/support
www.12voltdata.com/forum

SETTINGS AND FEATURES

CHIME ADJUSTMENT

Chime volume adjustment will only work if the chimes are played by the vehicle speakers (some Ford vehicles generate the chime in the cluster or with dedicated speakers in the back of the vehicle).

CHIME ADJUSTMENT PROCEDURE:

- Set the audio source to OFF.
- Activate door or parking assist chime.
- Adjust the chime volume using the volume knob.

MAESTRO AR PROGRAMMABLE FEATURES

These tone control features can be adjusted in the settings of the radio.

FACTORY CONTROL FEATURES:

- Bass Tone Control
Subwoofer Volume
- Mid Tone Control
Not applicable
- Treble Tone Control
Tweeter Output Gain
- Surround Control
Not applicable
- Speed Compensated Volume
None

INSTALLATION INSTRUCTIONS

STEP 1

- Remove the factory amplifier (refer to wire chart for amplifier location).
- Configure the 2 pin connectors on the AR-F02 T-harness as shown on the wiring diagram.

STEP 2

- Connect the factory amplifier harnesses to the AR-F02 T-harness.

STEP 3

- Connect the wires from the AR-F02 T-harness to the aftermarket amplifier.

Note 1:

If you are running your own speaker wires from the amplifier to the speakers, this step is not necessary.

Note 2:

The amplifier output colors and labels on the F02 T-harness do not correspond to the vehicle. For vehicle specific wiring designation, see the wiring chart.

- Plug the connector from the AR-F02 T-Harness into the aftermarket amplifier.
- Plug the Data cable to the data port of the aftermarket amplifier.

STEP 4

- Connect all the harnesses to the Maestro AR module.

Note 3:

The aftermarket amplifier will not turn OFF with the key, it will shut down when the vehicle goes to sleep.

Note 4:

There will no longer be any audible beeps from the OEM radio when using the radio menus.

- For technical assistance call 1-866-427-2999 or e-mail "maestro.support@idatalink.com". Visit us at "maestro.idatalink.com/support" and "www.12voltdata.com/forum/"

WIRING DIAGRAM

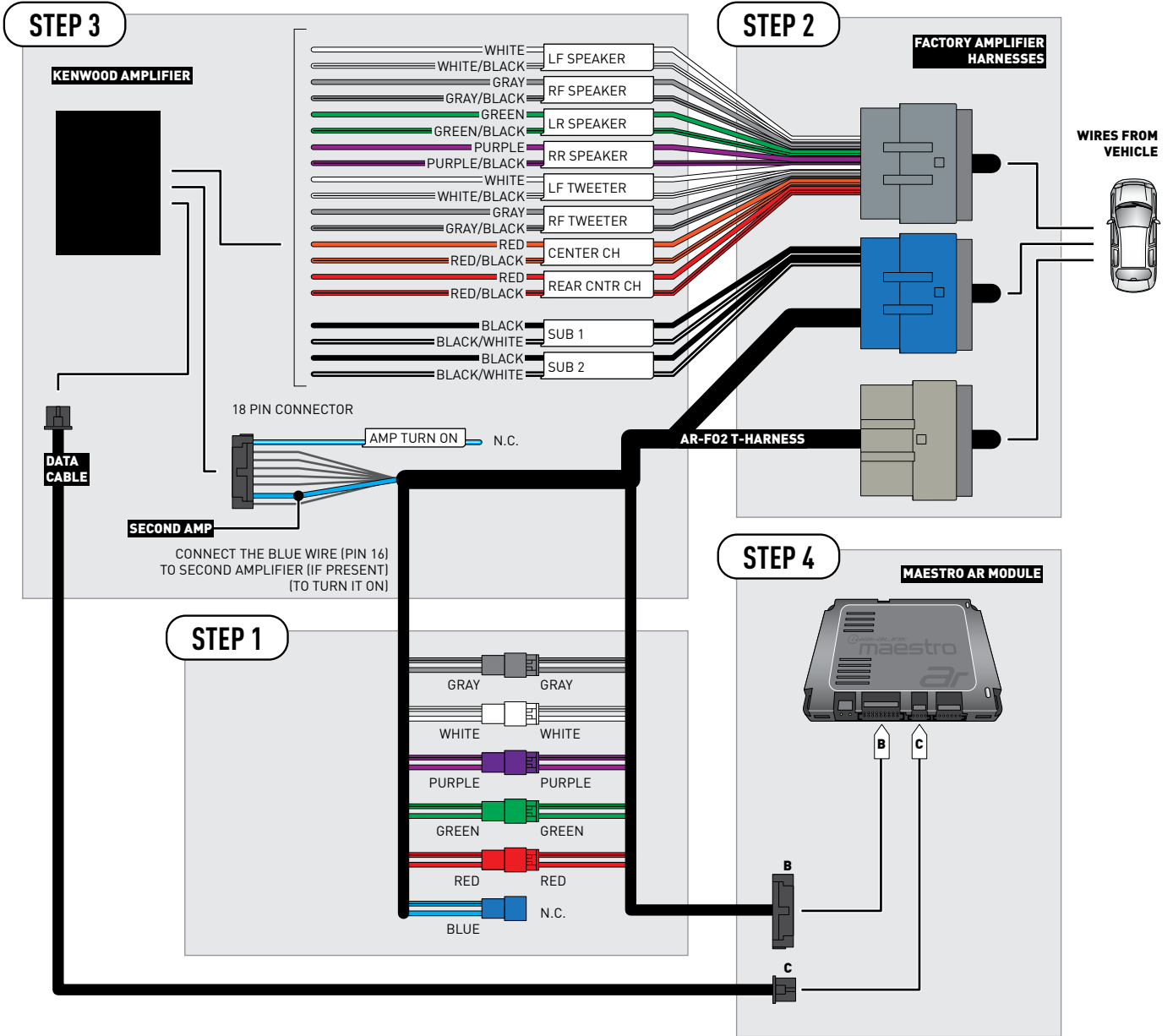

CONNECTION NOT REQUIRED

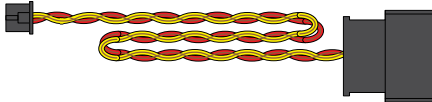

VEHICLE WIRE REFERENCE CHART

T-Harness Wires		Vehicle Wires	
Wire Tag	Wire Color	Speaker Wire Description	Component Position
LF SPEAKER	White	Left Front Speaker (+)	~
	White/Black	Left Front Speaker (-)	
LF TWEETER	White	Left Front Tweeter (+)	~
	White/Black	Left Front Tweeter (-)	
RF SPEAKER	Gray	Right Front Speaker (+)	~
	Gray/Black	Right Front Speaker (-)	
RF TWEETER	Gray	Right Front Tweeter (+)	~
	Gray/Black	Right Front Tweeter (-)	
LR SPEAKER	Green	Left Rear Speaker (+)	~
	Green/Black	Left Rear Speaker (-)	
RR SPEAKER	Purple	Right Rear Speaker (+)	~
	Purple/Black	Right Rear Speaker (-)	
REAR CNTR CH	Red	Rear Center Channel (+)	~
	Red/Black	Rear Center Channel (-)	
CENTER CH	Orange	Front Center Channel (+)	~
	Orange/Black	Front Center Channel (-)	
SUB 1	Black	Left Rear Subwoofer (+)	~
	Black/White	Left Rear Subwoofer (-)	
SUB 2	Black	Right Rear Subwoofer (+)	~
	Black/White	Right Rear Subwoofer (-)	

Note: The amplifier output colors and labels on the AR-F02 T-harness do not correspond to the vehicle. For vehicle specific wiring designation, follow this wiring chart.

Amplifier location

Right front of luggage compartment



INSTALL GUIDE FORD MUSTANG WITH 12 SPEAKER SYSTEM 2019

ENABLE A SEAMLESS AFTERMARKET AMPLIFIER INSTALLATION,
WITHOUT CHANGING YOUR RADIO.



KENWOOD

PRODUCTS REQUIRED

iDatalink Maestro AR Amplifier Replacement Interface
iDatalink Maestro AR-F02 Installation Harness

OPTIONAL ACCESSORIES

Extension harness provided with
Kenwood amplifier

PROGRAMMED FIRMWARE

ADS-AR-FOR02

NOTICE: Automotive Data Solutions Inc. (ADS) recommends having this installation performed by a certified technician. Logos and trademarks used here in are the properties of their respective owners.

WELCOME

Congratulations on the purchase of your iDatalink Maestro AR Amplifier replacement solution. You are now a few simple steps away from enjoying your new car amplifier.

Before starting your installation, please ensure that your iDatalink Maestro module is programmed with the correct firmware for your vehicle and that you carefully review the install guide.

TABLE OF CONTENTS

Settings and Features	3
Installation Instructions	4
Wiring Diagram	5
Vehicle Wire Reference Chart	6

NEED HELP?

 1 866 427-2999

 maestro.support@idatalink.com

 maestro.idatalink.com/support
www.12voltdata.com/forum

SETTINGS AND FEATURES

CHIME ADJUSTMENT

Chime volume adjustment will only work if the chimes are played by the vehicle speakers (some Ford vehicles generate the chime in the cluster or with dedicated speakers in the back of the vehicle).

CHIME ADJUSTMENT PROCEDURE:

- Set the audio source to OFF.
- Activate door or parking assist chime.
- Adjust the chime volume using the volume knob.

MAESTRO AR PROGRAMMABLE FEATURES

These tone control features can be adjusted in the settings of the radio.

FACTORY CONTROL FEATURES:

- Bass Tone Control
Subwoofer Volume
- Mid Tone Control
Not applicable
- Treble Tone Control
Tweeter Output Gain
- Surround Control
Not applicable
- Speed Compensated Volume
None

INSTALLATION INSTRUCTIONS

- Determine if your vehicle is equipped with one or multiple amplifiers to refer to the appropriate wiring diagram.

STEP 1

- Remove the factory amplifier (refer to wire chart for amplifier location).
- Configure the 2 pin connectors on the AR-F02 T-harness as shown on the wiring diagram.

STEP 2

- Cut and isolate Yellow wire (pin 5) and Black wire (pin 16) of the blue connector of the aF02 T-Harness.
- Connect the factory amplifier harnesses to the AR-F02 T-harness.

STEP 3

- Connect the wires from the AR-F02 T-harness to the aftermarket amplifier.

Note 1:

If you are running your own speaker wires from the amplifier to the speakers, this step is not necessary.

Note 2:

The amplifier output colors and labels on the F02 T-harness do not correspond to the vehicle. For vehicle specific wiring designation, see the wiring chart.

- Plug the connector from the AR-F02 T-Harness into the aftermarket amplifier.
- Plug the Data cable to the data port of the aftermarket amplifier.

STEP 4

- Connect all the harnesses to the Maestro AR module.

Note 3:

The aftermarket amplifier will not turn OFF with the key, it will shut down when the vehicle goes to sleep.

Note 4:

There will no longer be any audible beeps from the OEM radio when using the radio menus.

- For technical assistance call 1-866-427-2999 or e-mail "maestro.support@idatalink.com". Visit us at "maestro.idatalink.com/support" and "www.12voltdata.com/forum/"

WIRING DIAGRAM

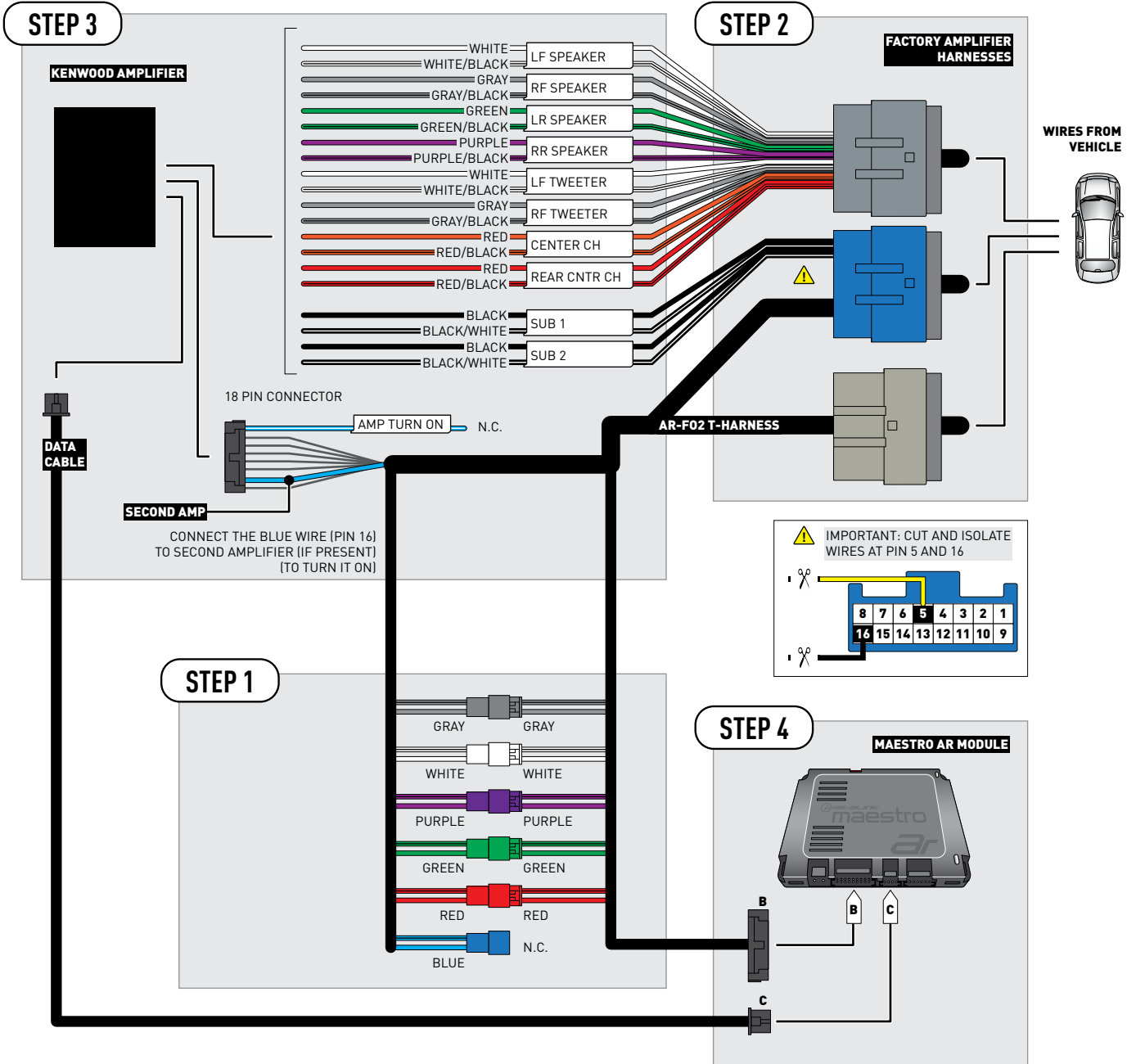

VEHICLE WIRE REFERENCE CHART

T-Harness Wires		Vehicle Wires	
Wire Tag	Wire Color	Speaker Wire Description	Component Position
LF SPEAKER	White	Left Front Woofer and Tweeter Speaker (+)	~
	White/Black	Left Front Woofer and Tweeter Speaker (-)	
LF TWEETER	White	Left Front MID (+)	~
	White/Black	Left Front MID (-)	
RF SPEAKER	Gray	Right Front Woofer and Tweeter Speaker (+)	~
	Gray/Black	Right Front Woofer and Tweeter Speaker (-)	
RF TWEETER	Gray	Right Front MID (+)	~
	Gray/Black	Right Front MID (-)	
LR SPEAKER	Green	Left Rear Speaker (+)	~
	Green/Black	Left Rear Speaker (-)	
RR SPEAKER	Purple	Right Rear Speaker (+)	~
	Purple/Black	Right Rear Speaker (-)	
REAR CNTR CH	Red	n/a	~
	Red/Black	n/a	
CENTER CH	Orange	Center Channel (+)	~
	Orange/Black	Center Channel (-)	
SUB 1	Black	Left Rear Subwoofer (+)	~
	Black/White	Left Rear Subwoofer (-)	
SUB 2	Black	Right Rear Subwoofer (+)	~
	Black/White	Right Rear Subwoofer (-)	

Note: The amplifier output colors and labels on the AR-F02 T-harness do not correspond to the vehicle. For vehicle specific wiring designation, follow this wiring chart.

Amplifier location

Above driver kick panel



INSTALL GUIDE FORD TAURUS 2013-2018

ENABLE A SEAMLESS AFTERMARKET AMPLIFIER INSTALLATION,
WITHOUT CHANGING YOUR RADIO.



KENWOOD

PRODUCTS REQUIRED

iDatalink Maestro AR Amplifier Replacement Interface
iDatalink Maestro AR-F02 Installation Harness

OPTIONAL ACCESSORIES

Extension harness provided with
Kenwood amplifier

PROGRAMMED FIRMWARE

ADS-AR-FOR02

NOTICE: Automotive Data Solutions Inc. (ADS) recommends having this installation performed by a certified technician. Logos and trademarks used here in are the properties of their respective owners.

WELCOME

Congratulations on the purchase of your iDatalink Maestro AR Amplifier replacement solution. You are now a few simple steps away from enjoying your new car amplifier.

Before starting your installation, please ensure that your iDatalink Maestro module is programmed with the correct firmware for your vehicle and that you carefully review the install guide.

TABLE OF CONTENTS

Settings and Features	3
Installation Instructions	4
Wiring Diagram	5
Vehicle Wire Reference Chart	6

NEED HELP?

 1 866 427-2999

 maestro.support@idatalink.com

 maestro.idatalink.com/support
www.12voltdata.com/forum

SETTINGS AND FEATURES

CHIME ADJUSTMENT

Chime volume adjustment will only work if the chimes are played by the vehicle speakers (some Ford vehicles generate the chime in the cluster or with dedicated speakers in the back of the vehicle).

CHIME ADJUSTMENT PROCEDURE:

- Set the audio source to OFF.
- Activate door or parking assist chime.
- Adjust the chime volume using the volume knob.

MAESTRO AR PROGRAMMABLE FEATURES

These tone control features can be adjusted in the settings of the radio.

FACTORY CONTROL FEATURES:

- Bass Tone Control
Subwoofer Volume
- Mid Tone Control
Not applicable
- Treble Tone Control
Tweeter Output Gain
- Surround Control
Not applicable
- Speed Compensated Volume
None

INSTALLATION INSTRUCTIONS

STEP 1

- Remove the factory amplifier (refer to wire chart for amplifier location).
- Configure the 2 pin connectors on the AR-F02 T-harness as shown on the wiring diagram.

STEP 2

- Connect the factory amplifier harnesses to the AR-F02 T-harness.

STEP 3

- Connect the wires from the AR-F02 T-harness to the aftermarket amplifier.

Note 1:

If you are running your own speaker wires from the amplifier to the speakers, this step is not necessary.

Note 2:

The amplifier output colors and labels on the F02 T-harness do not correspond to the vehicle. For vehicle specific wiring designation, see the wiring chart.

- Plug the connector from the AR-F02 T-Harness into the aftermarket amplifier.
- Plug the Data cable to the data port of the aftermarket amplifier.

STEP 4

- Connect all the harnesses to the Maestro AR module.

Note 3:

The aftermarket amplifier will not turn OFF with the key, it will shut down when the vehicle goes to sleep.

Note 4:

There will no longer be any audible beeps from the OEM radio when using the radio menus.

- For technical assistance call 1-866-427-2999 or e-mail "maestro.support@idatalink.com". Visit us at "maestro.idatalink.com/support" and "www.12voltdata.com/forum/"

WIRING DIAGRAM

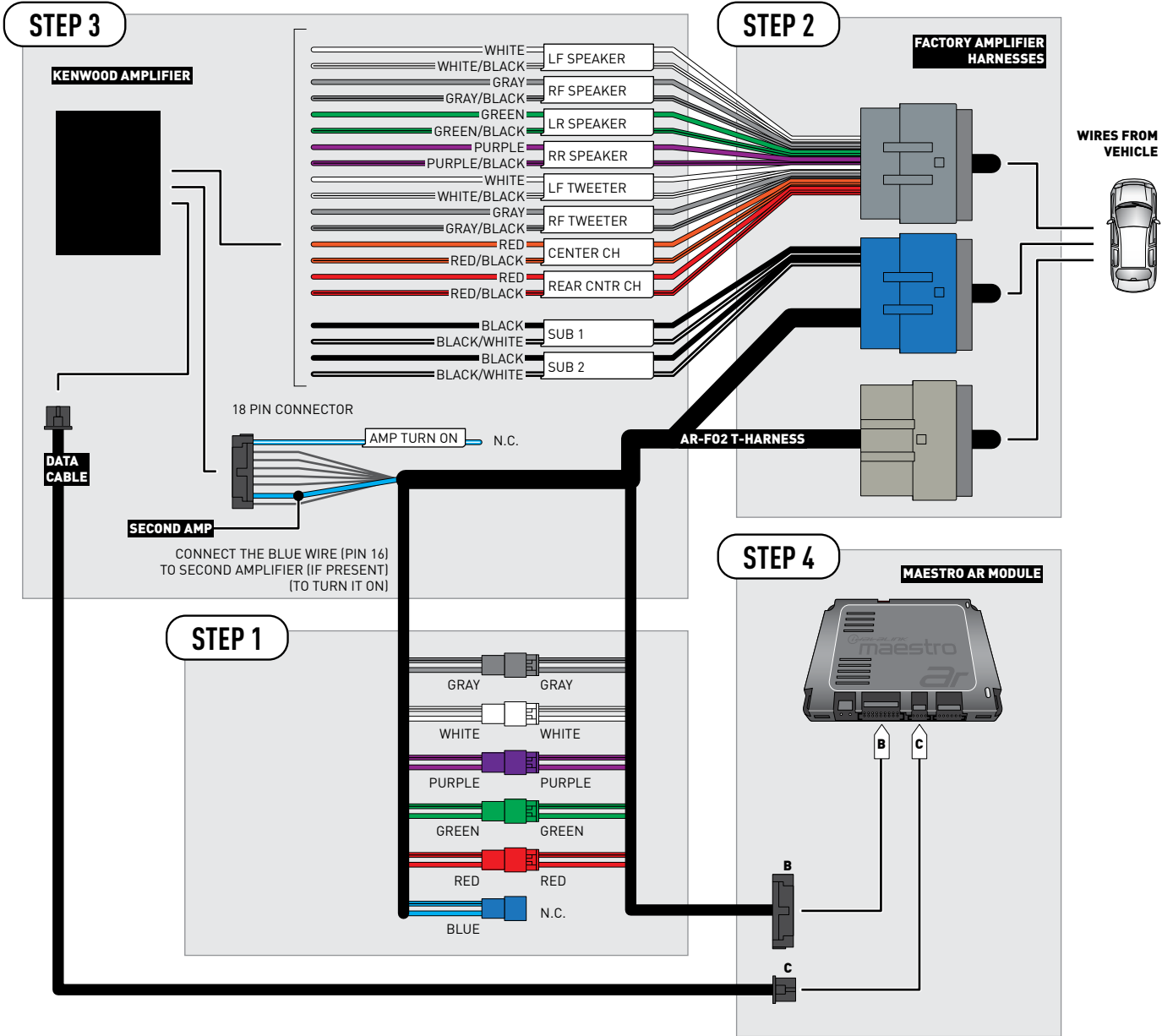

CONNECTION NOT REQUIRED

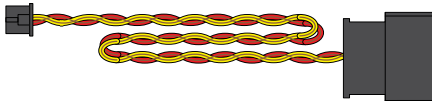

VEHICLE WIRE REFERENCE CHART

T-Harness Wires		Vehicle Wires	
Wire Tag	Wire Color	Speaker Wire Description	Component Position
LF SPEAKER	White	Left Front Speaker (+)	~
	White/Black	Left Front Speaker (-)	
LF TWEETER	White	Left Front Tweeter (+)	~
	White/Black	Left Front Tweeter (-)	
RF SPEAKER	Gray	Right Front Speaker (+)	~
	Gray/Black	Right Front Speaker (-)	
RF TWEETER	Gray	Right Front Tweeter (+)	~
	Gray/Black	Right Front Tweeter (-)	
LR SPEAKER	Green	Left Rear Speaker (+)	~
	Green/Black	Left Rear Speaker (-)	
RR SPEAKER	Purple	Right Rear Speaker (+)	~
	Purple/Black	Right Rear Speaker (-)	
REAR CNTR CH	Red	Rear Center Channel (+)	~
	Red/Black	Rear Center Channel (-)	
CENTER CH	Orange	Front Center Channel (+)	~
	Orange/Black	Front Center Channel (-)	
SUB 1	Black	Left Rear Subwoofer (+)	~
	Black/White	Left Rear Subwoofer (-)	
SUB 2	Black	Right Rear Subwoofer (+)	~
	Black/White	Right Rear Subwoofer (-)	

Note: The amplifier output colors and labels on the AR-F02 T-harness do not correspond to the vehicle. For vehicle specific wiring designation, follow this wiring chart.

Amplifier location

Left front of luggage compartment