



## HOW TO USE THIS INSTALL GUIDE

- 1** Open the Bookmarks menu and find your vehicle OR scroll down until you find the install guide for your vehicle.
- 2** Print only the pages for your vehicle using the advanced options in the Print menu.
- 3** Install your Maestro RR according to the guide for your vehicle.

## WARNING

Pressing the printer icon or “quick printing” this document will print all of the guides in this compilation.



# INSTALL GUIDE

# CHEVROLET CITY EXPRESS

# BLUETOOTH

# 2015-2018

RETAINS STEERING WHEEL CONTROLS AND ADDS GAUGES



#### PRODUCTS REQUIRED

iDatalink Maestro RR Radio Replacement Interface  
iDatalink Compatible Radio

#### PROGRAMMED FIRMWARE

ADS-RR(SI)-NIS01-DS

#### OPTIONAL ACCESSORIES



Click here for:

[Radar Integration Installation Guide](#)

[Radar Integration Owner's Guide for Kenwood and JVC Radios](#)

# WELCOME

Congratulations on the purchase of your iDatalink Maestro RR Radio replacement solution. You are now a few simple steps away from enjoying your new car radio with enhanced features.

Before starting your installation, please ensure that your iDatalink Maestro module is programmed with the correct firmware for your vehicle and that you carefully review the install guide.

**Please note that Maestro RR will only retain functionalities that were originally available in the vehicle.**

# NEED HELP?

 **1 866 427-2999**

 [support@idatalink.com](mailto:support@idatalink.com)

 [maestro.idatalink.com/support](http://maestro.idatalink.com/support)  
[www.12voltdata.com/forum](http://www.12voltdata.com/forum)

## TABLE OF CONTENTS

Wiring Diagram	<b>3</b>
Vehicle Wire Reference Chart	<b>4</b>

# WIRING DIAGRAM

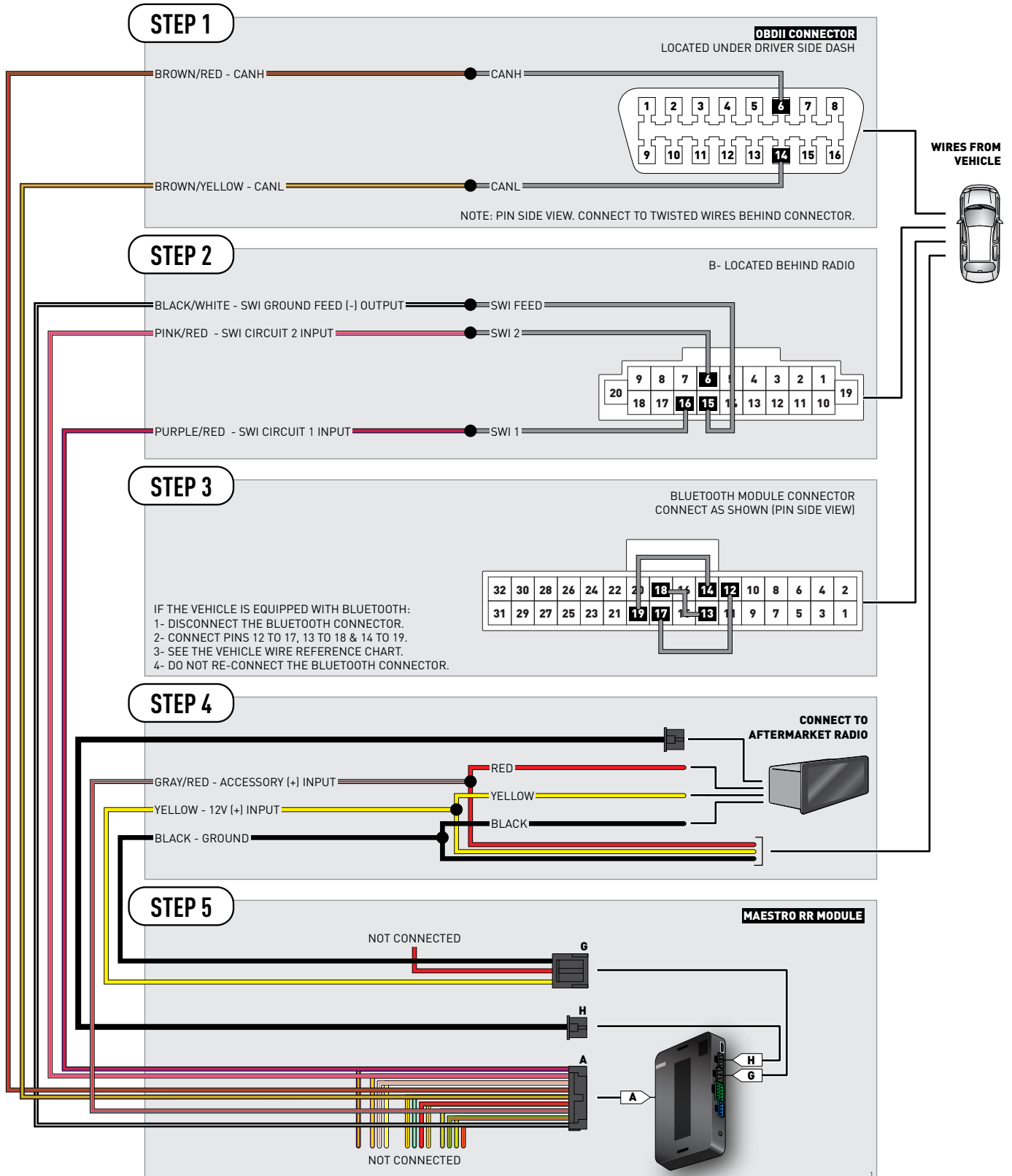

# VEHICLE WIRE REFERENCE CHART

Wire Description	Connector Name	Connector Color	Connector Type	Position	Wire Color	Polarity	Wire Location
CanH	A	~	16 pin	06	Blue	(DATA)	OBDII connector, under driver side dash
CanL	A	~	16 pin	14	Pink	(DATA)	OBDII connector, under driver side dash
SWI 1	B	~	20 pin	16	Yellow	(DATA)	Behind radio
SWI 2	B		20 pin	06	LtGreen	(DATA)	Behind radio
SWI Feed	B	~	20 pin	15	Black	(-)	Behind radio
BT-12	~	~	32 pin	12	Brown	~	Behind center dash, under radio
BT-13	~	~	32 pin	13	Yellow	~	Behind center dash, under radio
BT-14	~	~	32 pin	14	Bare	~	Behind center dash, under radio
BT-17	~	~	32 pin	17	LtGreen	~	Behind center dash, under radio
BT-18	~	~	32 pin	18	Yellow	~	Behind center dash, under radio
BT-19	~	~	32 pin	19	Black	~	Behind center dash, under radio



# INSTALL GUIDE

# CHEVROLET CITY EXPRESS

# NAV AND BLUETOOTH

# 2015-2018

RETAINS STEERING WHEEL CONTROLS AND ADDS GAUGES



#### PRODUCTS REQUIRED

iDatalink Maestro RR Radio Replacement Interface  
iDatalink Compatible Radio

#### PROGRAMMED FIRMWARE

ADS-RR(SI)-NIS01-DS

#### OPTIONAL ACCESSORIES



Click here for:

[Radar Integration Installation Guide](#)

[Radar Integration Owner's Guide for Kenwood and JVC Radios](#)

# WELCOME

Congratulations on the purchase of your iDatalink Maestro RR Radio replacement solution. You are now a few simple steps away from enjoying your new car radio with enhanced features.

Before starting your installation, please ensure that your iDatalink Maestro module is programmed with the correct firmware for your vehicle and that you carefully review the install guide.

**Please note that Maestro RR will only retain functionalities that were originally available in the vehicle.**

# NEED HELP?

 **1 866 427-2999**

 [support@idatalink.com](mailto:support@idatalink.com)

 [maestro.idatalink.com/support](http://maestro.idatalink.com/support)  
[www.12voltdata.com/forum](http://www.12voltdata.com/forum)

## TABLE OF CONTENTS

Wiring Diagram	<b>3</b>
Vehicle Wire Reference Chart	<b>4</b>

# WIRING DIAGRAM

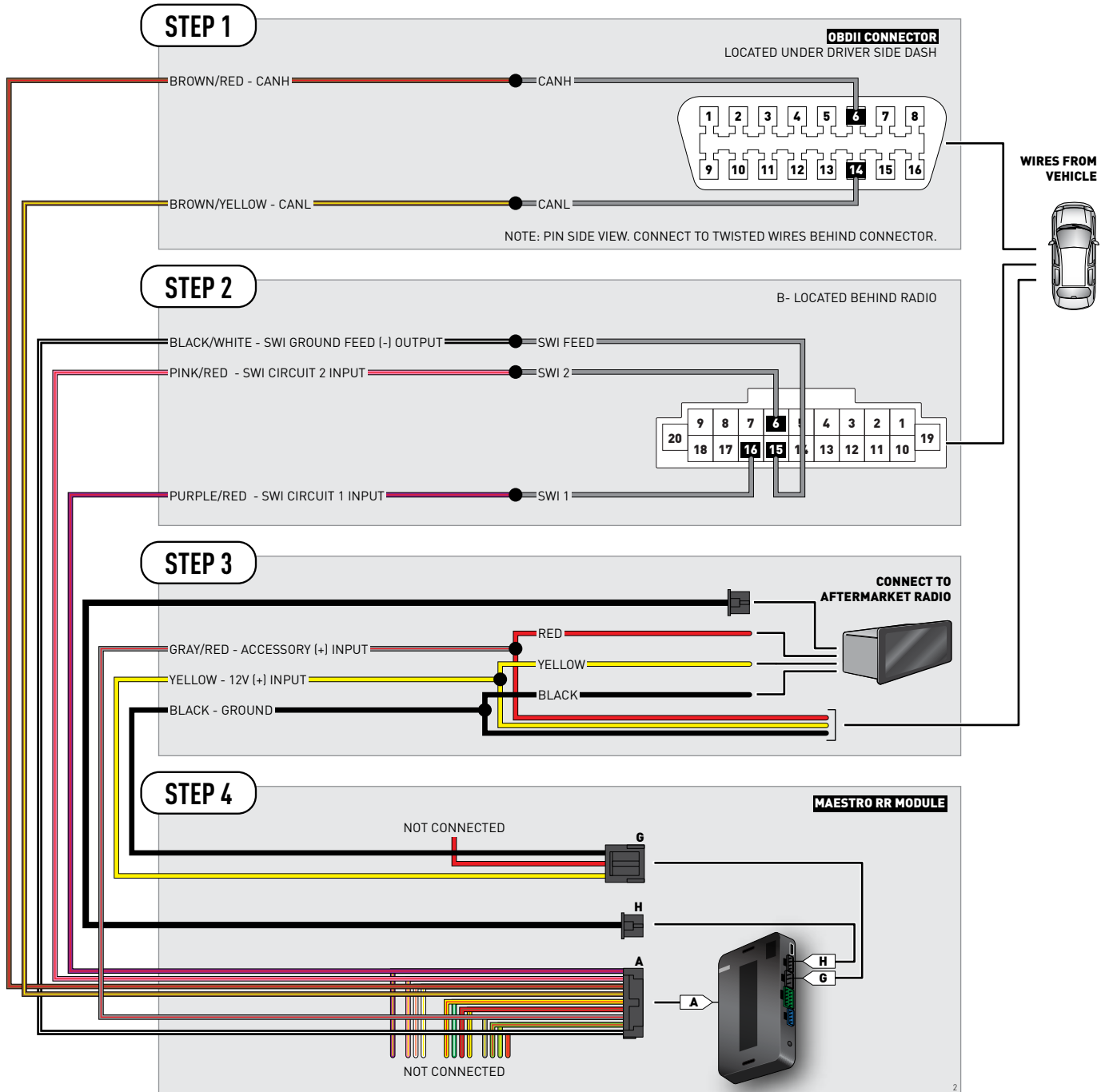



# VEHICLE WIRE REFERENCE CHART

Wire Description	Connector Name	Connector Color	Connector Type	Position	Wire Color	Polarity	Wire Location
CanH	A	~	16 pin	06	Blue	[DATA]	OBDII connector, under driver side dash
CanL	A	~	16 pin	14	Pink	[DATA]	OBDII connector, under driver side dash
SWI 1	B	~	20 pin	16	Yellow	[DATA]	Behind radio
SWI 2	B		20 pin	06	Brown	[DATA]	Behind radio
SWI Feed	B	~	20 pin	15	Bare	(-)	Behind radio

# iDatalink maestro *RR*

## INSTALL GUIDE NISSAN 370 BASE 2009-2018

RETAINS STEERING WHEEL CONTROLS AND ADDS GAUGES



### PRODUCTS REQUIRED

iDatalink Maestro RR Radio Replacement Interface  
iDatalink Compatible Radio

### PROGRAMMED FIRMWARE

ADS-RR(SI)-NIS01-DS

### OPTIONAL ACCESSORIES

**K4O**<sup>™</sup>  
ELECTRONICS

Click here for:

[Radar Integration Installation Guide](#)

[Radar Integration Owner's Guide for Kenwood and JVC Radios](#)

# WELCOME

Congratulations on the purchase of your iDatalink Maestro RR Radio replacement solution. You are now a few simple steps away from enjoying your new car radio with enhanced features.

Before starting your installation, please ensure that your iDatalink Maestro module is programmed with the correct firmware for your vehicle and that you carefully review the install guide.

**Please note that Maestro RR will only retain functionalities that were originally available in the vehicle.**

# NEED HELP?

 **1 866 427-2999**

 [support@idatalink.com](mailto:support@idatalink.com)

 [maestro.idatalink.com/support](http://maestro.idatalink.com/support)  
[www.12voltdata.com/forum](http://www.12voltdata.com/forum)

## TABLE OF CONTENTS

Wiring Diagram	<b>3</b>
Vehicle Wire Reference Chart	<b>4</b>

# WIRING DIAGRAM



# VEHICLE WIRE REFERENCE CHART

Wire Description	Connector Name	Connector Color	Connector Type	Position	Wire Color	Polarity	Wire Location
CanH	A	~	16 pin	06	Blue	(DATA)	OBDII connector, under driver side dash
CanL	A	~	16 pin	14	Pink	(DATA)	OBDII connector, under driver side dash
SWI 1	B	~	20 pin	16	Blue	(DATA)	Behind radio
SWI 2	B		20 pin	06	Pink	(DATA)	Behind radio
SWI Feed	B	~	20 pin	15	Black	(-)	Behind radio



# INSTALL GUIDE NISSAN 370 BLUETOOTH 2009-2018

RETAINS STEERING WHEEL CONTROLS AND ADDS GAUGES



#### PRODUCTS REQUIRED

iDatalink Maestro RR Radio Replacement Interface  
iDatalink Compatible Radio

#### PROGRAMMED FIRMWARE

ADS-RR(SI)-NIS01-DS

#### OPTIONAL ACCESSORIES



Click here for:

[Radar Integration Installation Guide](#)

[Radar Integration Owner's Guide for Kenwood and JVC Radios](#)

# WELCOME

Congratulations on the purchase of your iDatalink Maestro RR Radio replacement solution. You are now a few simple steps away from enjoying your new car radio with enhanced features.

Before starting your installation, please ensure that your iDatalink Maestro module is programmed with the correct firmware for your vehicle and that you carefully review the install guide.

**Please note that Maestro RR will only retain functionalities that were originally available in the vehicle.**

# NEED HELP?

 **1 866 427-2999**

 [support@idatalink.com](mailto:support@idatalink.com)

 [maestro.idatalink.com/support](http://maestro.idatalink.com/support)  
[www.12voltdata.com/forum](http://www.12voltdata.com/forum)

## TABLE OF CONTENTS

Wiring Diagram	<b>3</b>
Vehicle Wire Reference Chart	<b>4</b>

# WIRING DIAGRAM

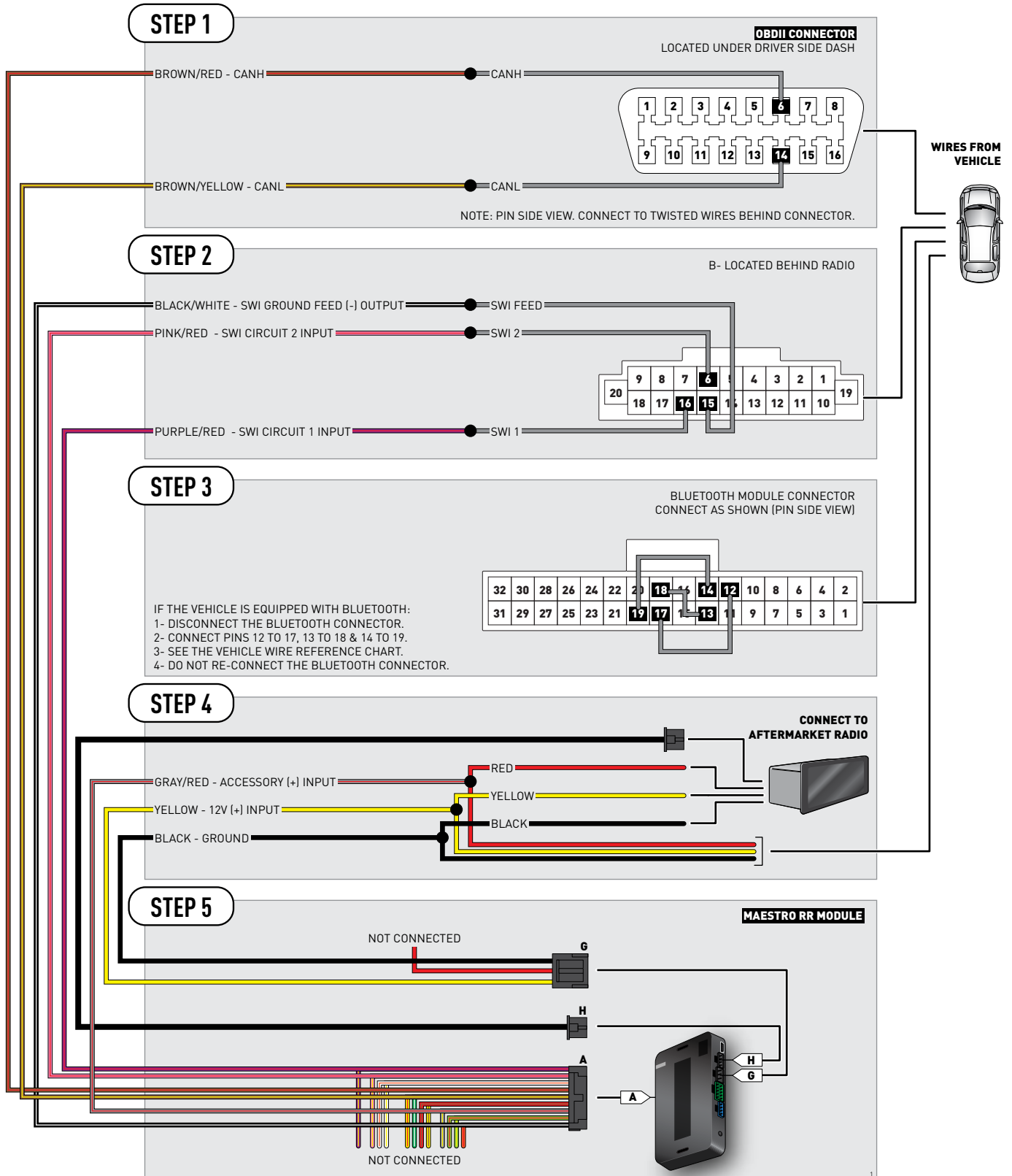



# VEHICLE WIRE REFERENCE CHART

Wire Description	Connector Name	Connector Color	Connector Type	Position	Wire Color	Polarity	Wire Location
CanH	A	~	16 pin	06	Blue	(DATA)	OBDII connector, under driver side dash
CanL	A	~	16 pin	14	Pink	(DATA)	OBDII connector, under driver side dash
SWI 1	B	~	20 pin	16	Blue	(DATA)	Behind radio
SWI 2	B	~	20 pin	06	Pink	(DATA)	Behind radio
SWI Feed	B	~	20 pin	15	Black	(-)	Behind radio
BT-12	~	~	32 pin	12	Pink	~	Trunk, left side
BT-13	~	~	32 pin	13	Blue	~	Trunk, left side
BT-14	~	~	32 pin	14	Black	~	Trunk, left side
BT-17	~	~	32 pin	17	White	~	Trunk, left side
BT-18	~	~	32 pin	18	Blue or Gray	~	Trunk, left side
BT-19	~	~	32 pin	19	Black	~	Trunk, left side



# INSTALL GUIDE

# NISSAN 370

# NAV AND BLUETOOTH

# 2009-2018

RETAINS STEERING WHEEL CONTROLS AND ADDS GAUGES



#### PRODUCTS REQUIRED

iDatalink Maestro RR Radio Replacement Interface  
iDatalink Compatible Radio

#### PROGRAMMED FIRMWARE

ADS-RR(SI)-NIS01-DS

#### OPTIONAL ACCESSORIES



Click here for:

[Radar Integration Installation Guide](#)

[Radar Integration Owner's Guide for Kenwood and JVC Radios](#)

# WELCOME

Congratulations on the purchase of your iDatalink Maestro RR Radio replacement solution. You are now a few simple steps away from enjoying your new car radio with enhanced features.

Before starting your installation, please ensure that your iDatalink Maestro module is programmed with the correct firmware for your vehicle and that you carefully review the install guide.

**Please note that Maestro RR will only retain functionalities that were originally available in the vehicle.**

# NEED HELP?

 **1 866 427-2999**

 [support@idatalink.com](mailto:support@idatalink.com)

 [maestro.idatalink.com/support](http://maestro.idatalink.com/support)  
[www.12voltdata.com/forum](http://www.12voltdata.com/forum)

## TABLE OF CONTENTS

Wiring Diagram	<b>3</b>
Vehicle Wire Reference Chart	<b>4</b>

# WIRING DIAGRAM



# VEHICLE WIRE REFERENCE CHART

Wire Description	Connector Name	Connector Color	Connector Type	Position	Wire Color	Polarity	Wire Location
CanH	A	~	16 pin	06	Blue	(DATA)	OBDII connector, under driver side dash
CanL	A	~	16 pin	14	Pink	(DATA)	OBDII connector, under driver side dash
SWI 1	B	~	20 pin	16	Blue	(DATA)	Behind radio
SWI 2	B		20 pin	06	Pink	(DATA)	Behind radio
SWI Feed	B	~	20 pin	15	Black	(-)	Behind radio



# INSTALL GUIDE

# NISSAN ALTIMA

# BLUETOOTH

# 2009-2012

RETAINS STEERING WHEEL CONTROLS AND ADDS GAUGES



#### PRODUCTS REQUIRED

iDatalink Maestro RR Radio Replacement Interface  
iDatalink Compatible Radio

#### PROGRAMMED FIRMWARE

ADS-RR(SI)-NIS01-DS

#### OPTIONAL ACCESSORIES



Click here for:

[Radar Integration Installation Guide](#)

[Radar Integration Owner's Guide for Kenwood and JVC Radios](#)

# WELCOME

Congratulations on the purchase of your iDatalink Maestro RR Radio replacement solution. You are now a few simple steps away from enjoying your new car radio with enhanced features.

Before starting your installation, please ensure that your iDatalink Maestro module is programmed with the correct firmware for your vehicle and that you carefully review the install guide.

**Please note that Maestro RR will only retain functionalities that were originally available in the vehicle.**

# NEED HELP?

 **1 866 427-2999**

 [support@idatalink.com](mailto:support@idatalink.com)

 [maestro.idatalink.com/support](http://maestro.idatalink.com/support)  
[www.12voltdata.com/forum](http://www.12voltdata.com/forum)

## TABLE OF CONTENTS

Wiring Diagram	<b>3</b>
Vehicle Wire Reference Chart	<b>4</b>

# WIRING DIAGRAM

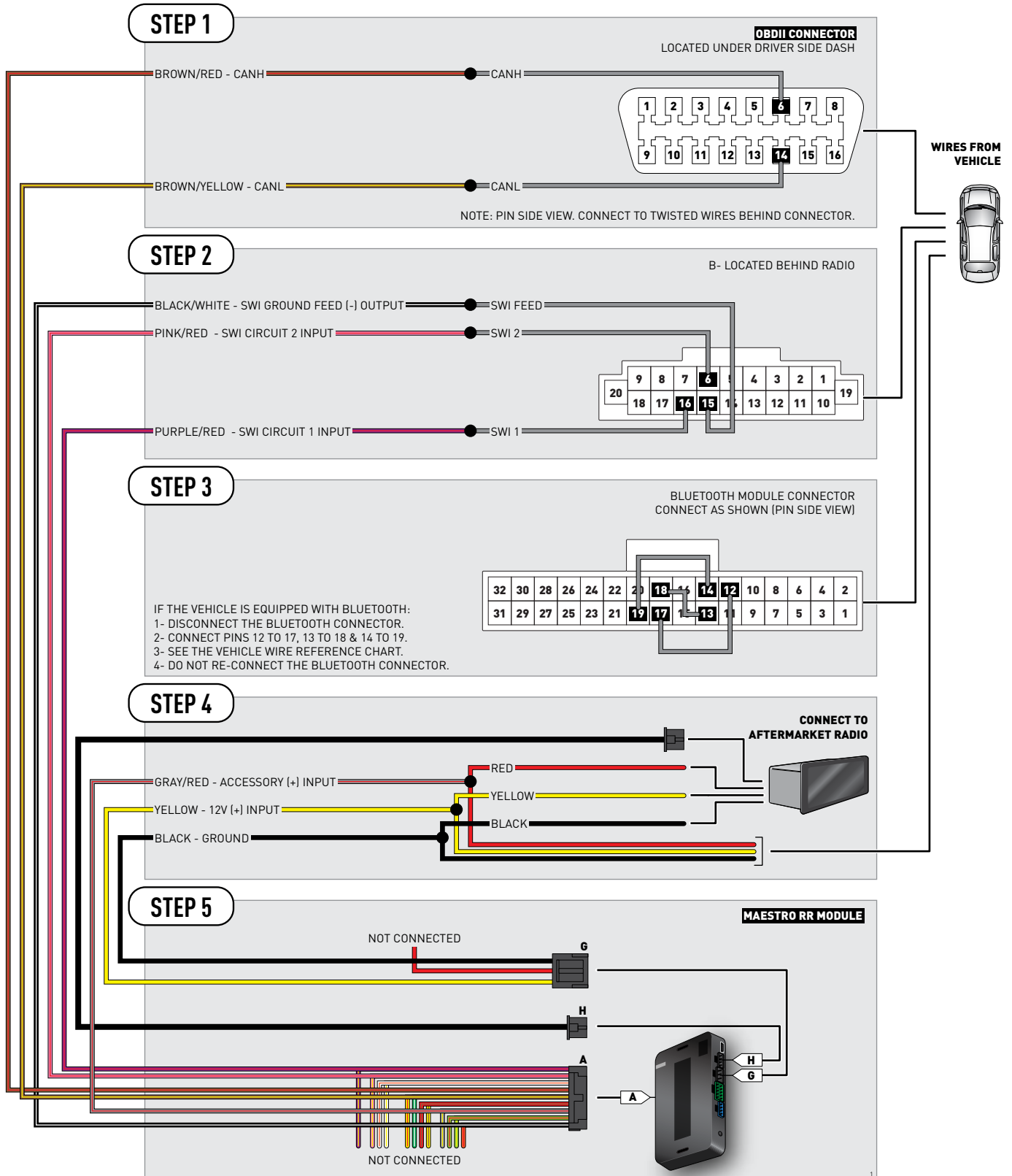



# VEHICLE WIRE REFERENCE CHART

Wire Description	Connector Name	Connector Color	Connector Type	Position	Wire Color	Polarity	Wire Location
CanH	A	~	16 pin	06	Blue	(DATA)	OBDII connector, under driver side dash
CanL	A	~	16 pin	14	Pink	(DATA)	OBDII connector, under driver side dash
SWI 1	B	~	20 pin	16	Gray/Blue	(DATA)	Behind radio
SWI 2	B		20 pin	06	White/Green	(DATA)	Behind radio
SWI Feed	B	~	20 pin	15	Blue/Black	(-)	Behind radio
BT-12	~	~	32 pin	12	White/Green	~	Trunk, under center shelf
BT-13	~	~	32 pin	13	Gray/Blue	~	Trunk, under center shelf
BT-14	~	~	32 pin	14	Blue/Black	~	Trunk, under center shelf
BT-17	~	~	32 pin	17	White/Green	~	Trunk, under center shelf
BT-18	~	~	32 pin	18	Gray/Blue	~	Trunk, under center shelf
BT-19	~	~	32 pin	19	Blue/Black	~	Trunk, under center shelf



# INSTALL GUIDE

# NISSAN ALTIMA

# NAV AND BLUETOOTH

# 2010-2012

RETAINS STEERING WHEEL CONTROLS AND ADDS GAUGES



#### PRODUCTS REQUIRED

iDatalink Maestro RR Radio Replacement Interface  
iDatalink Compatible Radio

#### PROGRAMMED FIRMWARE

ADS-RR(SI)-NIS01-DS

#### OPTIONAL ACCESSORIES



Click here for:

[Radar Integration Installation Guide](#)

[Radar Integration Owner's Guide for Kenwood and JVC Radios](#)

# WELCOME

Congratulations on the purchase of your iDatalink Maestro RR Radio replacement solution. You are now a few simple steps away from enjoying your new car radio with enhanced features.

Before starting your installation, please ensure that your iDatalink Maestro module is programmed with the correct firmware for your vehicle and that you carefully review the install guide.

**Please note that Maestro RR will only retain functionalities that were originally available in the vehicle.**

# NEED HELP?

 **1 866 427-2999**

 [support@idatalink.com](mailto:support@idatalink.com)

 [maestro.idatalink.com/support](http://maestro.idatalink.com/support)  
[www.12voltdata.com/forum](http://www.12voltdata.com/forum)

## TABLE OF CONTENTS

Wiring Diagram	<b>3</b>
Vehicle Wire Reference Chart	<b>4</b>

# WIRING DIAGRAM



# VEHICLE WIRE REFERENCE CHART

Wire Description	Connector Name	Connector Color	Connector Type	Position	Wire Color	Polarity	Wire Location
CanH	A	~	16 pin	06	Blue	(DATA)	OBDII connector, under driver side dash
CanL	A	~	16 pin	14	Pink	(DATA)	OBDII connector, under driver side dash
SWI 1	B	~	20 pin	16	Gray/Blue	(DATA)	Behind radio
SWI 2	B		20 pin	06	White/Green	(DATA)	Behind radio
SWI Feed	B	~	20 pin	15	Blue/Black	(-)	Behind radio



# INSTALL GUIDE NISSAN ARMADA

## 2009-2015

RETAINS STEERING WHEEL CONTROLS AND ADDS GAUGES



### PRODUCTS REQUIRED

iDatalink Maestro RR Radio Replacement Interface  
iDatalink Compatible Radio

### PROGRAMMED FIRMWARE

ADS-RR(SI)-NIS01-DS

### OPTIONAL ACCESSORIES



Click here for:

[Radar Integration Installation Guide](#)

[Radar Integration Owner's Guide for Kenwood and JVC Radios](#)

# WELCOME

Congratulations on the purchase of your iDatalink Maestro RR Radio replacement solution. You are now a few simple steps away from enjoying your new car radio with enhanced features.

Before starting your installation, please ensure that your iDatalink Maestro module is programmed with the correct firmware for your vehicle and that you carefully review the install guide.

**Please note that Maestro RR will only retain functionalities that were originally available in the vehicle.**

# NEED HELP?

 **1 866 427-2999**

 [support@idatalink.com](mailto:support@idatalink.com)

 [maestro.idatalink.com/support](http://maestro.idatalink.com/support)  
[www.12voltdata.com/forum](http://www.12voltdata.com/forum)

## TABLE OF CONTENTS

Wiring Diagram	<b>3</b>
Vehicle Wire Reference Chart	<b>4</b>

# WIRING DIAGRAM

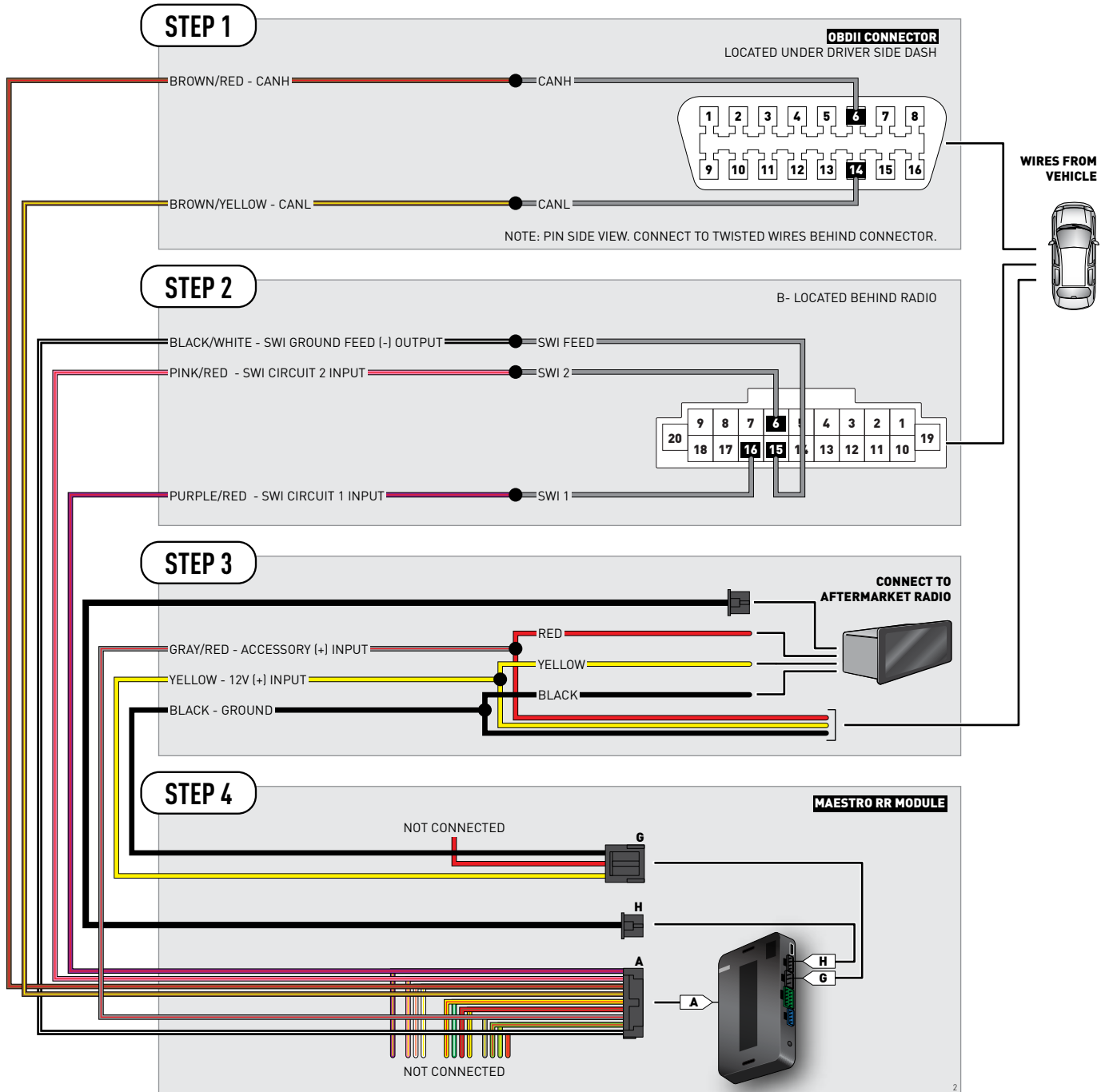



# VEHICLE WIRE REFERENCE CHART

Wire Description	Connector Name	Connector Color	Connector Type	Position	Wire Color	Polarity	Wire Location
CanH	A	~	16 pin	06	Blue	[DATA]	OBDII connector, under driver side dash
CanL	A	~	16 pin	14	Pink	[DATA]	OBDII connector, under driver side dash
SWI 1	B	~	20 pin	16	Brown	[DATA]	Behind radio
SWI 2	B		20 pin	06	Yellow	[DATA]	Behind radio
SWI Feed	B	~	20 pin	15	Black	(-)	Behind radio

# iDatalink maestro *RR*

## INSTALL GUIDE NISSAN CUBE

# 2009

RETAINS STEERING WHEEL CONTROLS AND ADDS GAUGES



### PRODUCTS REQUIRED

iDatalink Maestro RR Radio Replacement Interface  
iDatalink Compatible Radio

### PROGRAMMED FIRMWARE

ADS-RR(SI)-NIS01-DS

### OPTIONAL ACCESSORIES

**K4O**<sup>™</sup>  
ELECTRONICS

Click here for:

[Radar Integration Installation Guide](#)

[Radar Integration Owner's Guide for Kenwood and JVC Radios](#)

# WELCOME

Congratulations on the purchase of your iDatalink Maestro RR Radio replacement solution. You are now a few simple steps away from enjoying your new car radio with enhanced features.

Before starting your installation, please ensure that your iDatalink Maestro module is programmed with the correct firmware for your vehicle and that you carefully review the install guide.

**Please note that Maestro RR will only retain functionalities that were originally available in the vehicle.**

# NEED HELP?

 **1 866 427-2999**

 [support@idatalink.com](mailto:support@idatalink.com)

 [maestro.idatalink.com/support](http://maestro.idatalink.com/support)  
[www.12voltdata.com/forum](http://www.12voltdata.com/forum)

## TABLE OF CONTENTS

Wiring Diagram	<b>3</b>
Vehicle Wire Reference Chart	<b>4</b>

# WIRING DIAGRAM



# VEHICLE WIRE REFERENCE CHART

Wire Description	Connector Name	Connector Color	Connector Type	Position	Wire Color	Polarity	Wire Location
CanH	A	~	16 pin	06	Blue	(DATA)	OBDII connector, under driver side dash
CanL	A	~	16 pin	14	Pink	(DATA)	OBDII connector, under driver side dash
SWI 1	B	~	20 pin	16	Gray/Red	(DATA)	Behind radio
SWI 2	B		20 pin	06	White/Blue	(DATA)	Behind radio
SWI Feed	B	~	20 pin	15	Blue/Green	(-)	Behind radio

# iDatalink maestro *RR*

## INSTALL GUIDE NISSAN CUBE

# 2010

RETAINS STEERING WHEEL CONTROLS AND ADDS GAUGES



### PRODUCTS REQUIRED

iDatalink Maestro RR Radio Replacement Interface  
iDatalink Compatible Radio

### PROGRAMMED FIRMWARE

ADS-RR(SI)-NIS01-DS

### OPTIONAL ACCESSORIES

**K4O**<sup>™</sup>  
ELECTRONICS

Click here for:

[Radar Integration Installation Guide](#)

[Radar Integration Owner's Guide for Kenwood and JVC Radios](#)

# WELCOME

Congratulations on the purchase of your iDatalink Maestro RR Radio replacement solution. You are now a few simple steps away from enjoying your new car radio with enhanced features.

Before starting your installation, please ensure that your iDatalink Maestro module is programmed with the correct firmware for your vehicle and that you carefully review the install guide.

**Please note that Maestro RR will only retain functionalities that were originally available in the vehicle.**

# NEED HELP?

 **1 866 427-2999**

 [support@idatalink.com](mailto:support@idatalink.com)

 [maestro.idatalink.com/support](http://maestro.idatalink.com/support)  
[www.12voltdata.com/forum](http://www.12voltdata.com/forum)

## TABLE OF CONTENTS

Wiring Diagram	3
Vehicle Wire Reference Chart	4

# WIRING DIAGRAM

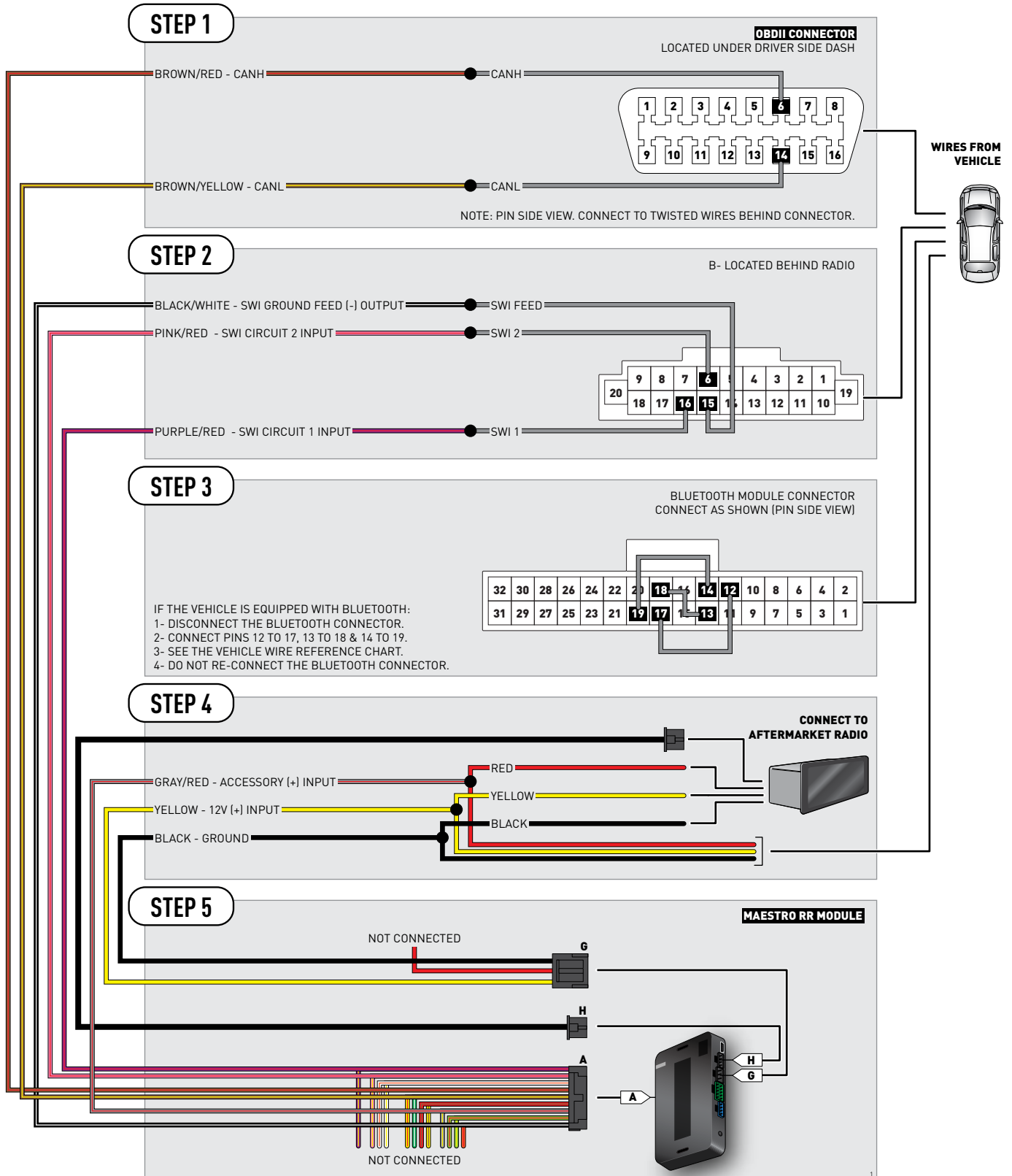



# VEHICLE WIRE REFERENCE CHART

Wire Description	Connector Name	Connector Color	Connector Type	Position	Wire Color	Polarity	Wire Location
CanH	A	~	16 pin	06	Blue	(DATA)	OBDII connector, under driver side dash
CanL	A	~	16 pin	14	Pink	(DATA)	OBDII connector, under driver side dash
SWI 1	B	~	20 pin	16	Gray/Red	(DATA)	Behind radio
SWI 2	B		20 pin	06	White/Green	(DATA)	Behind radio
SWI Feed	B	~	20 pin	15	Blue/Black	(-)	Behind radio
BT-12	~	~	32 pin	12	White	~	Behind glovebox, right side
BT-13	~	~	32 pin	13	LtBlue	~	Behind glovebox, right side
BT-14	~	~	32 pin	14	Gray	~	Behind glovebox, right side
BT-17	~	~	32 pin	17	Gray	~	Behind glovebox, right side
BT-18	~	~	32 pin	18	Pink	~	Behind glovebox, right side
BT-19	~	~	32 pin	19	Blue	~	Behind glovebox, right side



# INSTALL GUIDE NISSAN CUBE BLUETOOTH 2011-2014

RETAINS STEERING WHEEL CONTROLS AND ADDS GAUGES



#### PRODUCTS REQUIRED

iDatalink Maestro RR Radio Replacement Interface  
iDatalink Compatible Radio

#### PROGRAMMED FIRMWARE

ADS-RR(SI)-NIS01-DS

#### OPTIONAL ACCESSORIES



Click here for:

[Radar Integration Installation Guide](#)

[Radar Integration Owner's Guide for Kenwood and JVC Radios](#)

# WELCOME

Congratulations on the purchase of your iDatalink Maestro RR Radio replacement solution. You are now a few simple steps away from enjoying your new car radio with enhanced features.

Before starting your installation, please ensure that your iDatalink Maestro module is programmed with the correct firmware for your vehicle and that you carefully review the install guide.

**Please note that Maestro RR will only retain functionalities that were originally available in the vehicle.**

# NEED HELP?

 **1 866 427-2999**

 [support@idatalink.com](mailto:support@idatalink.com)

 [maestro.idatalink.com/support](http://maestro.idatalink.com/support)  
[www.12voltdata.com/forum](http://www.12voltdata.com/forum)

## TABLE OF CONTENTS

Wiring Diagram	<b>3</b>
Vehicle Wire Reference Chart	<b>4</b>

# WIRING DIAGRAM

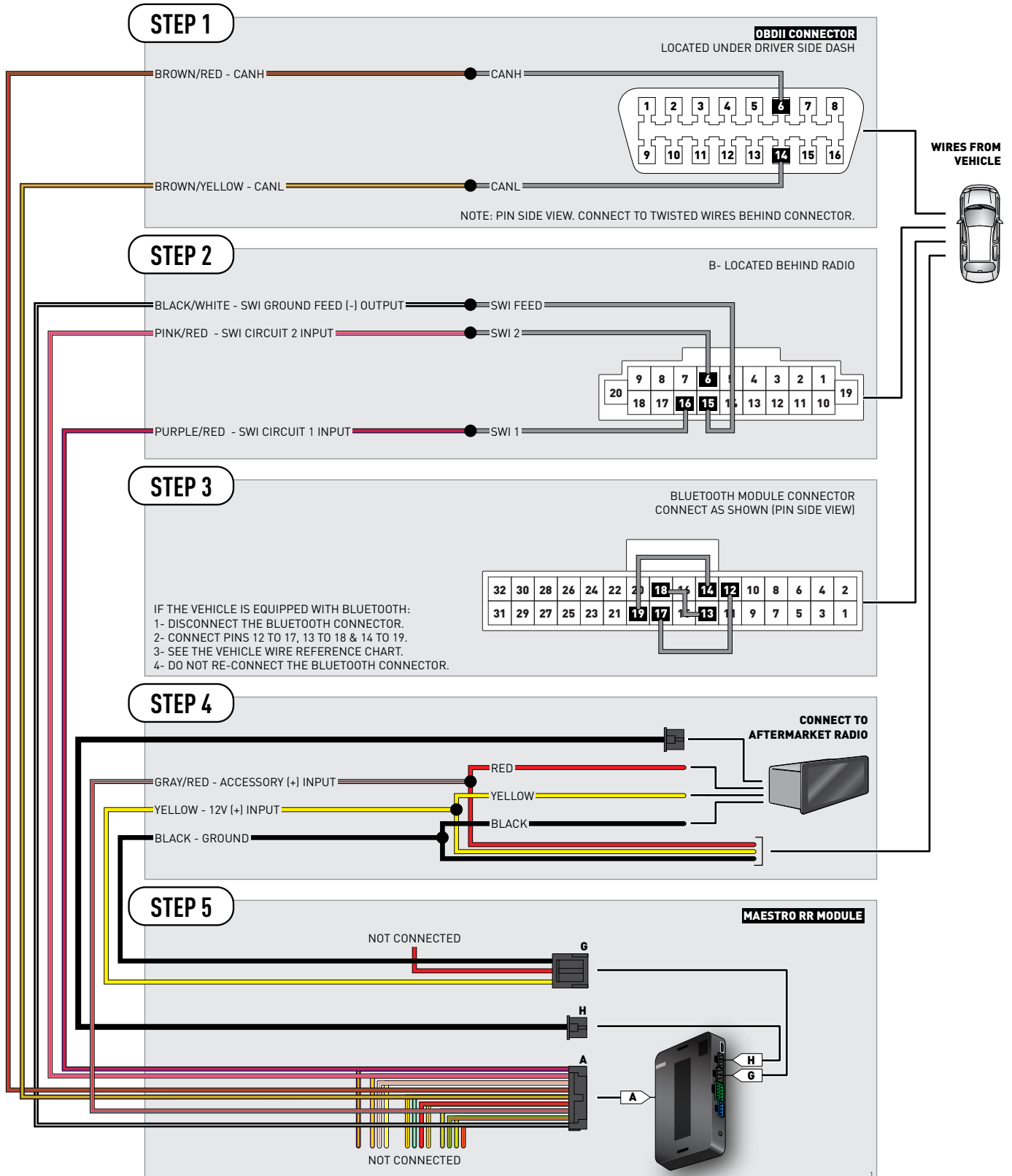

# VEHICLE WIRE REFERENCE CHART

Wire Description	Connector Name	Connector Color	Connector Type	Position	Wire Color	Polarity	Wire Location
CanH	A	~	16 pin	06	Blue	(DATA)	OBDII connector, under driver side dash
CanL	A	~	16 pin	14	Pink	(DATA)	OBDII connector, under driver side dash
SWI 1	B	~	20 pin	16	Gray/Red	(DATA)	Behind radio
SWI 2	B		20 pin	06	White/Green	(DATA)	Behind radio
SWI Feed	B	~	20 pin	15	Blue/Black	(-)	Behind radio
BT-12	~	~	32 pin	12	White	~	Behind glovebox, right side
BT-13	~	~	32 pin	13	LtBlue	~	Behind glovebox, right side
BT-14	~	~	32 pin	14	Gray	~	Behind glovebox, right side
BT-17	~	~	32 pin	17	Gray	~	Behind glovebox, right side
BT-18	~	~	32 pin	18	Pink	~	Behind glovebox, right side
BT-19	~	~	32 pin	19	Blue	~	Behind glovebox, right side



# INSTALL GUIDE

# NISSAN CUBE

# NAV AND BLUETOOTH

# 2011-2014

RETAINS STEERING WHEEL CONTROLS AND ADDS GAUGES



#### PRODUCTS REQUIRED

iDatalink Maestro RR Radio Replacement Interface  
iDatalink Compatible Radio

#### PROGRAMMED FIRMWARE

ADS-RR(SI)-NIS01-DS

#### OPTIONAL ACCESSORIES



Click here for:

[Radar Integration Installation Guide](#)

[Radar Integration Owner's Guide for Kenwood and JVC Radios](#)

# WELCOME

Congratulations on the purchase of your iDatalink Maestro RR Radio replacement solution. You are now a few simple steps away from enjoying your new car radio with enhanced features.

Before starting your installation, please ensure that your iDatalink Maestro module is programmed with the correct firmware for your vehicle and that you carefully review the install guide.

**Please note that Maestro RR will only retain functionalities that were originally available in the vehicle.**

# NEED HELP?

 **1 866 427-2999**

 [support@idatalink.com](mailto:support@idatalink.com)

 [maestro.idatalink.com/support](http://maestro.idatalink.com/support)  
[www.12voltdata.com/forum](http://www.12voltdata.com/forum)

## TABLE OF CONTENTS

Wiring Diagram	<b>3</b>
Vehicle Wire Reference Chart	<b>4</b>

# WIRING DIAGRAM

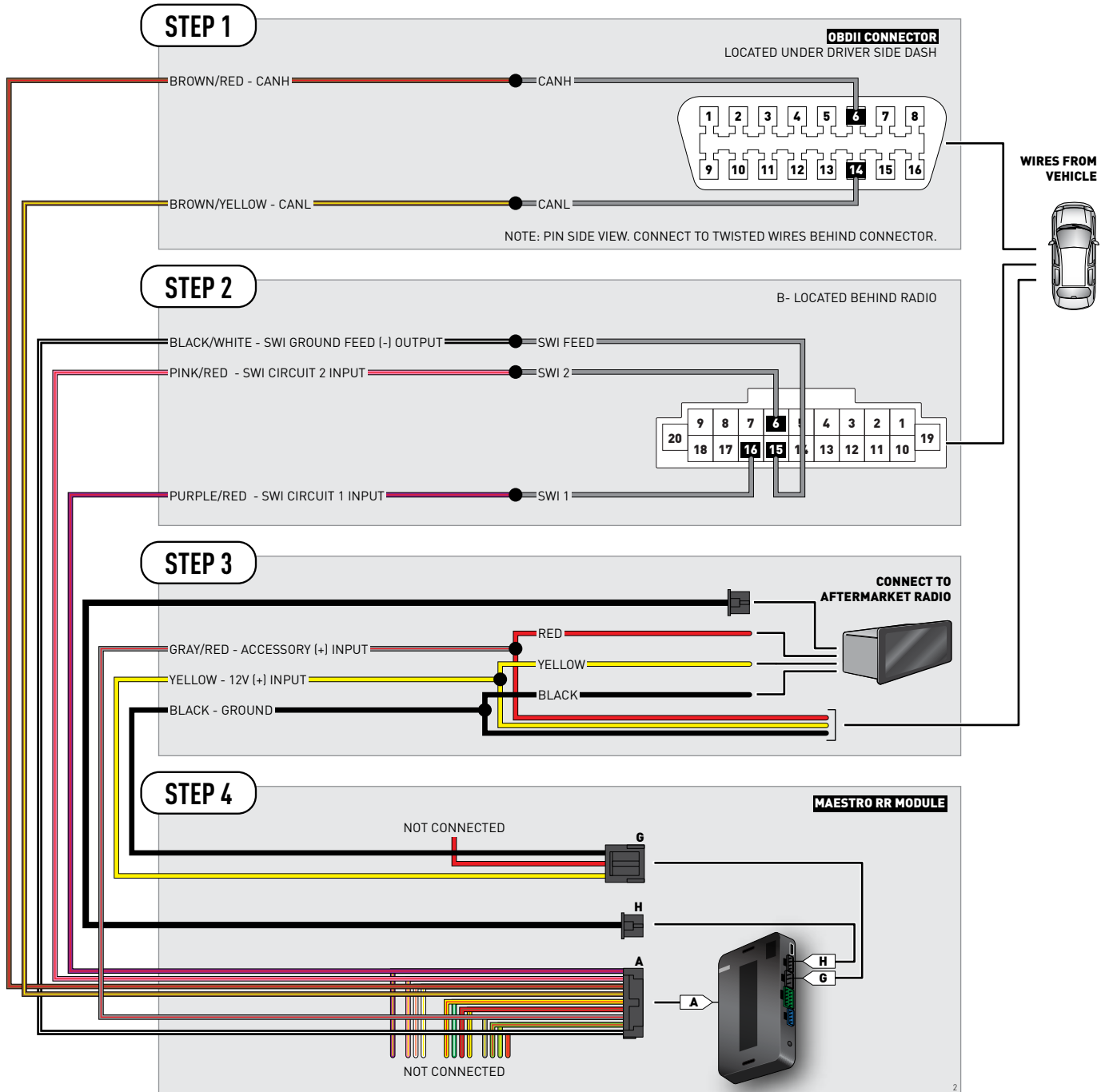



# VEHICLE WIRE REFERENCE CHART

Wire Description	Connector Name	Connector Color	Connector Type	Position	Wire Color	Polarity	Wire Location
CanH	A	~	16 pin	06	Blue	(DATA)	OBDII connector, under driver side dash
CanL	A	~	16 pin	14	Pink	(DATA)	OBDII connector, under driver side dash
SWI 1	B	~	20 pin	16	Gray/Red	(DATA)	Behind radio
SWI 2	B		20 pin	06	White/Blue	(DATA)	Behind radio
SWI Feed	B	~	20 pin	15	Blue/Green	(-)	Behind radio



# INSTALL GUIDE NISSAN FRONTIER

## 2009-2012

RETAINS STEERING WHEEL CONTROLS AND ADDS GAUGES



### PRODUCTS REQUIRED

iDatalink Maestro RR Radio Replacement Interface  
iDatalink Compatible Radio

### PROGRAMMED FIRMWARE

ADS-RR(SI)-NIS01-DS

### OPTIONAL ACCESSORIES



Click here for:

[Radar Integration Installation Guide](#)

[Radar Integration Owner's Guide for Kenwood and JVC Radios](#)

# WELCOME

Congratulations on the purchase of your iDatalink Maestro RR Radio replacement solution. You are now a few simple steps away from enjoying your new car radio with enhanced features.

Before starting your installation, please ensure that your iDatalink Maestro module is programmed with the correct firmware for your vehicle and that you carefully review the install guide.

**Please note that Maestro RR will only retain functionalities that were originally available in the vehicle.**

# NEED HELP?

 **1 866 427-2999**

 [support@idatalink.com](mailto:support@idatalink.com)

 [maestro.idatalink.com/support](http://maestro.idatalink.com/support)  
[www.12voltdata.com/forum](http://www.12voltdata.com/forum)

## TABLE OF CONTENTS

Wiring Diagram	<b>3</b>
Vehicle Wire Reference Chart	<b>4</b>

# WIRING DIAGRAM

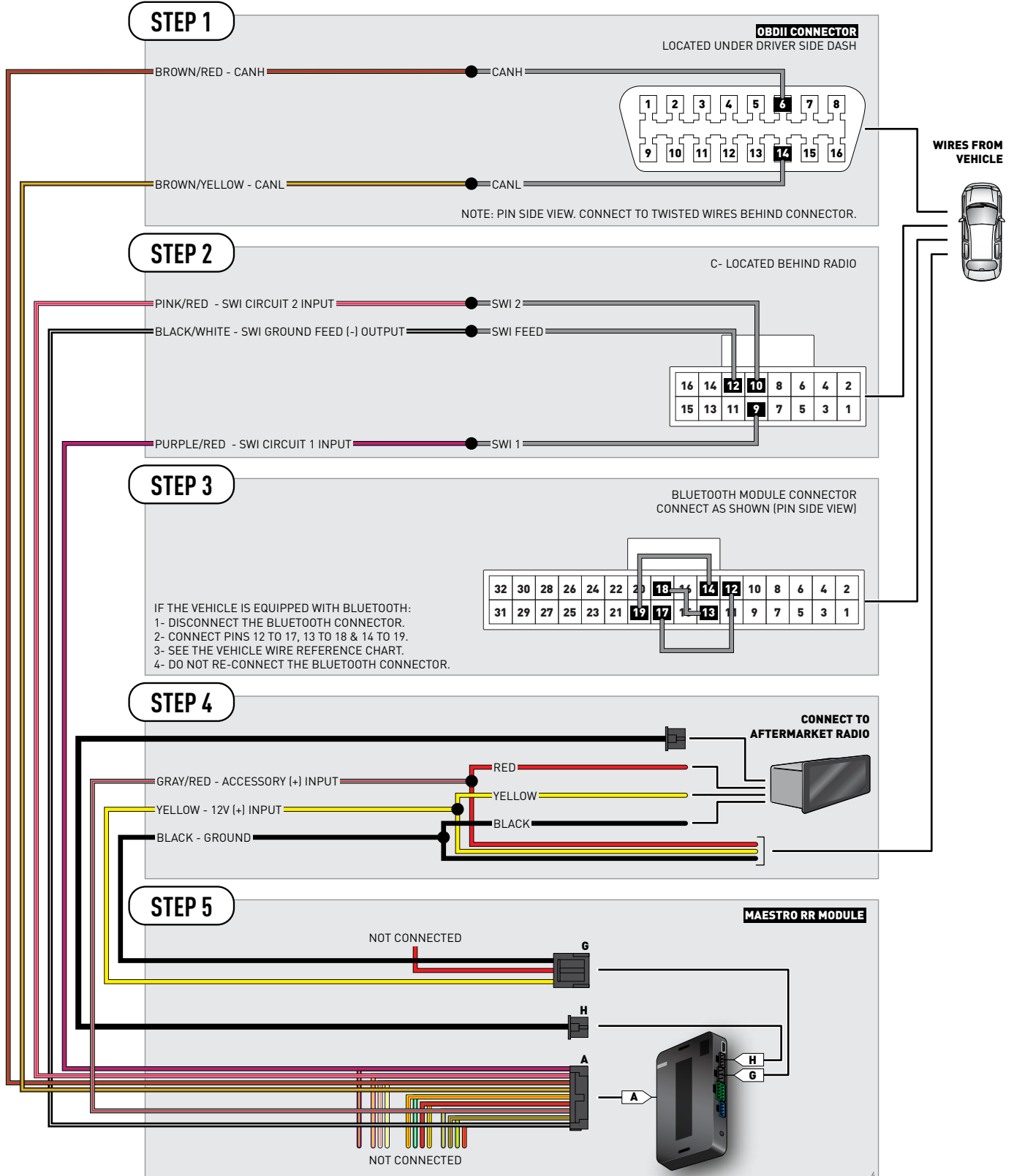

# VEHICLE WIRE REFERENCE CHART

Wire Description	Connector Name	Connector Color	Connector Type	Position	Wire Color	Polarity	Wire Location
CanH	A	~	16 pin	06	Blue	(DATA)	OBDII connector, under driver side dash
CanL	A	~	16 pin	14	Pink	(DATA)	OBDII connector, under driver side dash
SWI 1	C	~	16 pin	09	LtGreen	(DATA)	Behind radio
SWI 2	C	~	16 pin	10	Purple	(DATA)	Behind radio
SWI Feed	C	~	16 pin	12	Orange	(-)	Behind radio
BT-12	~	~	32 pin	12	Brown	~	Under passenger seat
BT-13	~	~	32 pin	13	Blue	~	Under passenger seat
BT-14	~	~	32 pin	14	Green	~	Under passenger seat
BT-17	~	~	32 pin	17	Purple	~	Under passenger seat
BT-18	~	~	32 pin	18	Green	~	Under passenger seat
BT-19	~	~	32 pin	19	Orange	~	Under passenger seat



# INSTALL GUIDE

# NISSAN FRONTIER

# BLUETOOTH

# 2013-2018

RETAINS STEERING WHEEL CONTROLS AND ADDS GAUGES



#### PRODUCTS REQUIRED

iDatalink Maestro RR Radio Replacement Interface  
iDatalink Compatible Radio

#### PROGRAMMED FIRMWARE

ADS-RR(SI)-NIS01-DS

#### OPTIONAL ACCESSORIES



Click here for:

[Radar Integration Installation Guide](#)

[Radar Integration Owner's Guide for Kenwood and JVC Radios](#)

# WELCOME

Congratulations on the purchase of your iDatalink Maestro RR Radio replacement solution. You are now a few simple steps away from enjoying your new car radio with enhanced features.

Before starting your installation, please ensure that your iDatalink Maestro module is programmed with the correct firmware for your vehicle and that you carefully review the install guide.

**Please note that Maestro RR will only retain functionalities that were originally available in the vehicle.**

# NEED HELP?

 **1 866 427-2999**

 **[support@idatalink.com](mailto:support@idatalink.com)**

 **[maestro.idatalink.com/support](http://maestro.idatalink.com/support)  
[www.12voltdata.com/forum](http://www.12voltdata.com/forum)**

## TABLE OF CONTENTS

Wiring Diagram	<b>3</b>
Vehicle Wire Reference Chart	<b>4</b>

# WIRING DIAGRAM

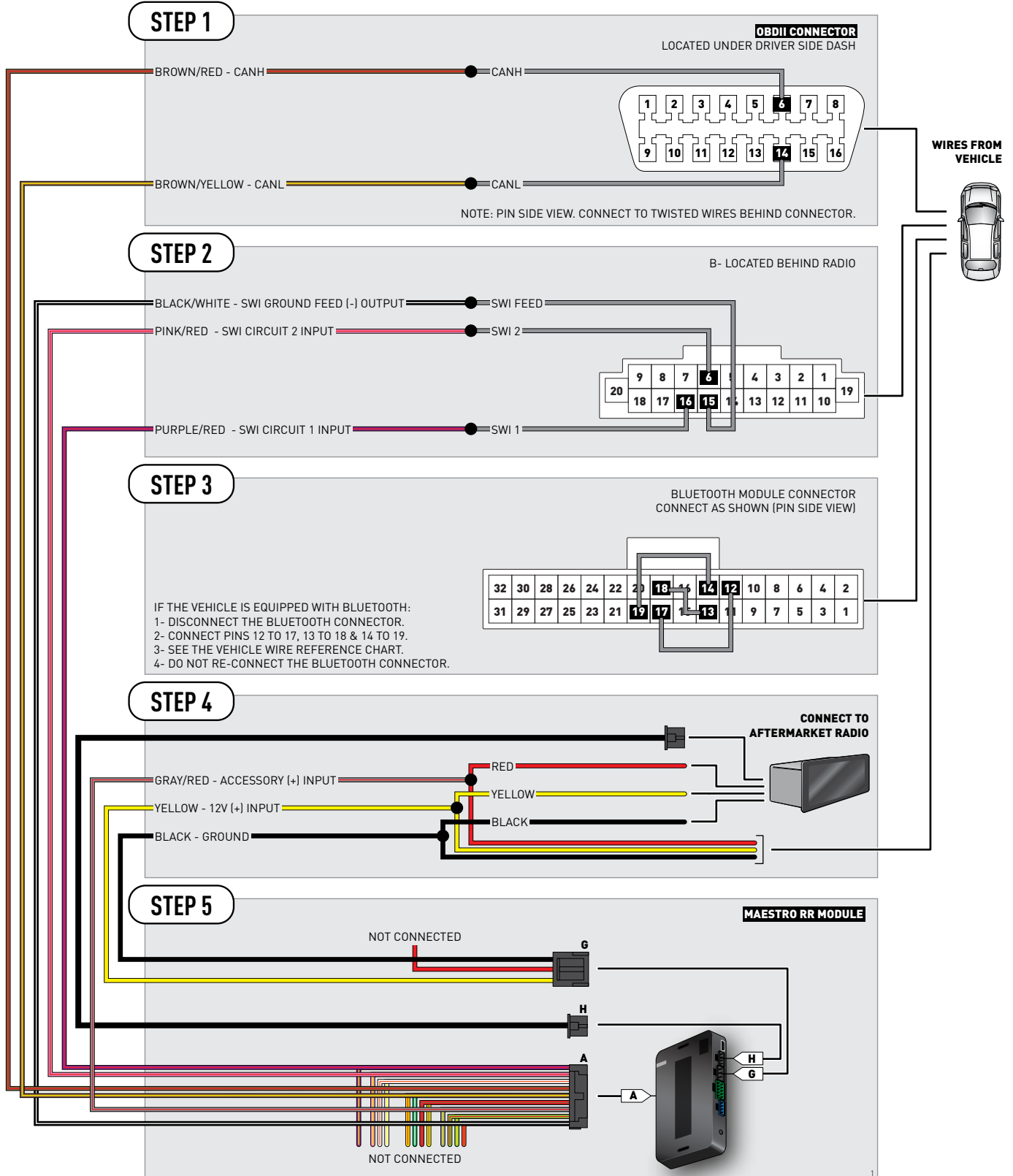



# VEHICLE WIRE REFERENCE CHART

Wire Description	Connector Name	Connector Color	Connector Type	Position	Wire Color	Polarity	Wire Location
CanH	A	~	16 pin	06	Blue	(DATA)	OBDII connector, under driver side dash
CanL	A	~	16 pin	14	Pink	(DATA)	OBDII connector, under driver side dash
SWI 1	B	~	20 pin	16	Green	(DATA)	Behind radio
SWI 2	B	~	20 pin	06	Purple	(DATA)	Behind radio
SWI Feed	B	~	20 pin	15	Orange	(-)	Behind radio
BT-12	~	~	32 pin	12	Brown	~	Under passenger seat
BT-13	~	~	32 pin	13	Blue	~	Under passenger seat
BT-14	~	~	32 pin	14	Green	~	Under passenger seat
BT-17	~	~	32 pin	17	Purple	~	Under passenger seat
BT-18	~	~	32 pin	18	Green	~	Under passenger seat
BT-19	~	~	32 pin	19	Orange	~	Under passenger seat



# INSTALL GUIDE

# NISSAN FRONTIER

# NAV AND BLUETOOTH

# 2013-2018

RETAINS STEERING WHEEL CONTROLS AND ADDS GAUGES



#### PRODUCTS REQUIRED

iDatalink Maestro RR Radio Replacement Interface  
iDatalink Compatible Radio

#### PROGRAMMED FIRMWARE

ADS-RR(SI)-NIS01-DS

#### OPTIONAL ACCESSORIES



Click here for:

[Radar Integration Installation Guide](#)

[Radar Integration Owner's Guide for Kenwood and JVC Radios](#)

# WELCOME

Congratulations on the purchase of your iDatalink Maestro RR Radio replacement solution. You are now a few simple steps away from enjoying your new car radio with enhanced features.

Before starting your installation, please ensure that your iDatalink Maestro module is programmed with the correct firmware for your vehicle and that you carefully review the install guide.

**Please note that Maestro RR will only retain functionalities that were originally available in the vehicle.**

# NEED HELP?

 **1 866 427-2999**

 **[support@idatalink.com](mailto:support@idatalink.com)**

 **[maestro.idatalink.com/support](http://maestro.idatalink.com/support)  
[www.12voltdata.com/forum](http://www.12voltdata.com/forum)**

## TABLE OF CONTENTS

Wiring Diagram	<b>3</b>
Vehicle Wire Reference Chart	<b>4</b>

# WIRING DIAGRAM



# VEHICLE WIRE REFERENCE CHART

Wire Description	Connector Name	Connector Color	Connector Type	Position	Wire Color	Polarity	Wire Location
CanH	A	~	16 pin	06	Blue	[DATA]	OBDII connector, under driver side dash
CanL	A	~	16 pin	14	Pink	[DATA]	OBDII connector, under driver side dash
SWI 1	B	~	20 pin	16	White	[DATA]	Behind radio
SWI 2	B	~	20 pin	06	Brown	[DATA]	Behind radio
SWI Feed	B	~	20 pin	15	Green	(-)	Behind radio

# iDatalink maestro *RR*

## INSTALL GUIDE NISSAN GTR

# 2009-2016

RETAINS STEERING WHEEL CONTROLS AND ADDS GAUGES



### PRODUCTS REQUIRED

iDatalink Maestro RR Radio Replacement Interface  
iDatalink Compatible Radio

### PROGRAMMED FIRMWARE

ADS-RR(SI)-NIS01-DS

### OPTIONAL ACCESSORIES

**K4O**<sup>™</sup>  
ELECTRONICS

Click here for:

[Radar Integration Installation Guide](#)

[Radar Integration Owner's Guide for Kenwood and JVC Radios](#)

# WELCOME

Congratulations on the purchase of your iDatalink Maestro RR Radio replacement solution. You are now a few simple steps away from enjoying your new car radio with enhanced features.

Before starting your installation, please ensure that your iDatalink Maestro module is programmed with the correct firmware for your vehicle and that you carefully review the install guide.

**Please note that Maestro RR will only retain functionalities that were originally available in the vehicle.**

# NEED HELP?

 **1 866 427-2999**

 [support@idatalink.com](mailto:support@idatalink.com)

 [maestro.idatalink.com/support](http://maestro.idatalink.com/support)  
[www.12voltdata.com/forum](http://www.12voltdata.com/forum)

## TABLE OF CONTENTS

Wiring Diagram	<b>3</b>
Vehicle Wire Reference Chart	<b>4</b>

# WIRING DIAGRAM

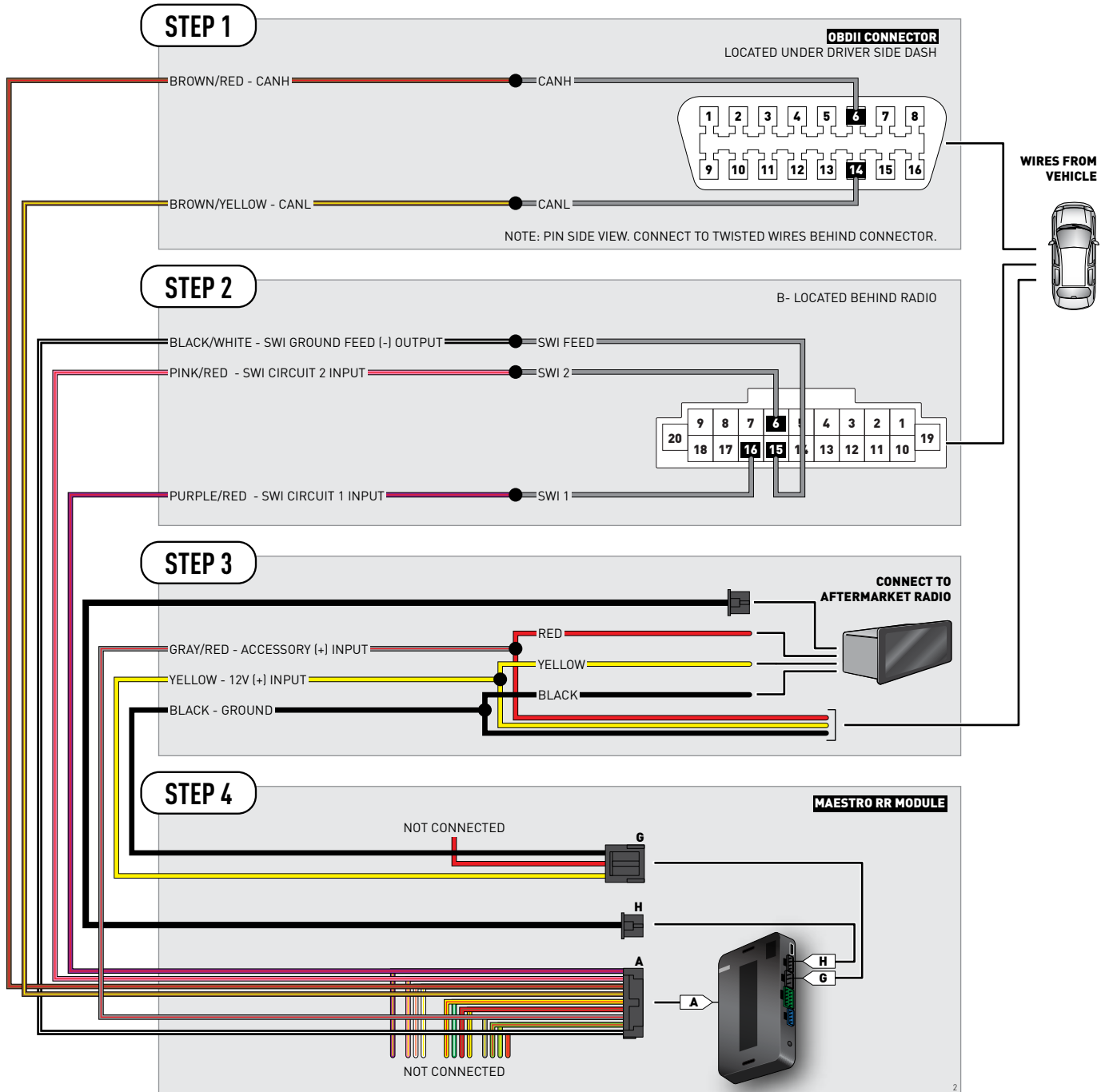



# VEHICLE WIRE REFERENCE CHART

Wire Description	Connector Name	Connector Color	Connector Type	Position	Wire Color	Polarity	Wire Location
CanH	A	~	16 pin	06	Blue	(DATA)	OBDII connector, under driver side dash
CanL	A	~	16 pin	14	Pink	(DATA)	OBDII connector, under driver side dash
SWI 1	B	~	20 pin	16	LtBlue	(DATA)	Behind radio
SWI 2	B		20 pin	06	Purple	(DATA)	Behind radio
SWI Feed	B	~	20 pin	15	Gray	(-)	Behind radio

iDatalink  
**maestro RR**

# INSTALL GUIDE

# NISSAN JUKE

# BLUETOOTH

# 2011-2014

RETAINS STEERING WHEEL CONTROLS AND ADDS GAUGES



#### PRODUCTS REQUIRED

iDatalink Maestro RR Radio Replacement Interface  
iDatalink Compatible Radio

#### PROGRAMMED FIRMWARE

ADS-RR(SI)-NIS01-DS

#### OPTIONAL ACCESSORIES

**K40**<sup>TM</sup>  
ELECTRONICS

Click here for:

[Radar Integration Installation Guide](#)

[Radar Integration Owner's Guide for Kenwood and JVC Radios](#)

# WELCOME

Congratulations on the purchase of your iDatalink Maestro RR Radio replacement solution. You are now a few simple steps away from enjoying your new car radio with enhanced features.

Before starting your installation, please ensure that your iDatalink Maestro module is programmed with the correct firmware for your vehicle and that you carefully review the install guide.

**Please note that Maestro RR will only retain functionalities that were originally available in the vehicle.**

# NEED HELP?

 **1 866 427-2999**

 [support@idatalink.com](mailto:support@idatalink.com)

 [maestro.idatalink.com/support](http://maestro.idatalink.com/support)  
[www.12voltdata.com/forum](http://www.12voltdata.com/forum)

## TABLE OF CONTENTS

Wiring Diagram	<b>3</b>
Vehicle Wire Reference Chart	<b>4</b>

# WIRING DIAGRAM

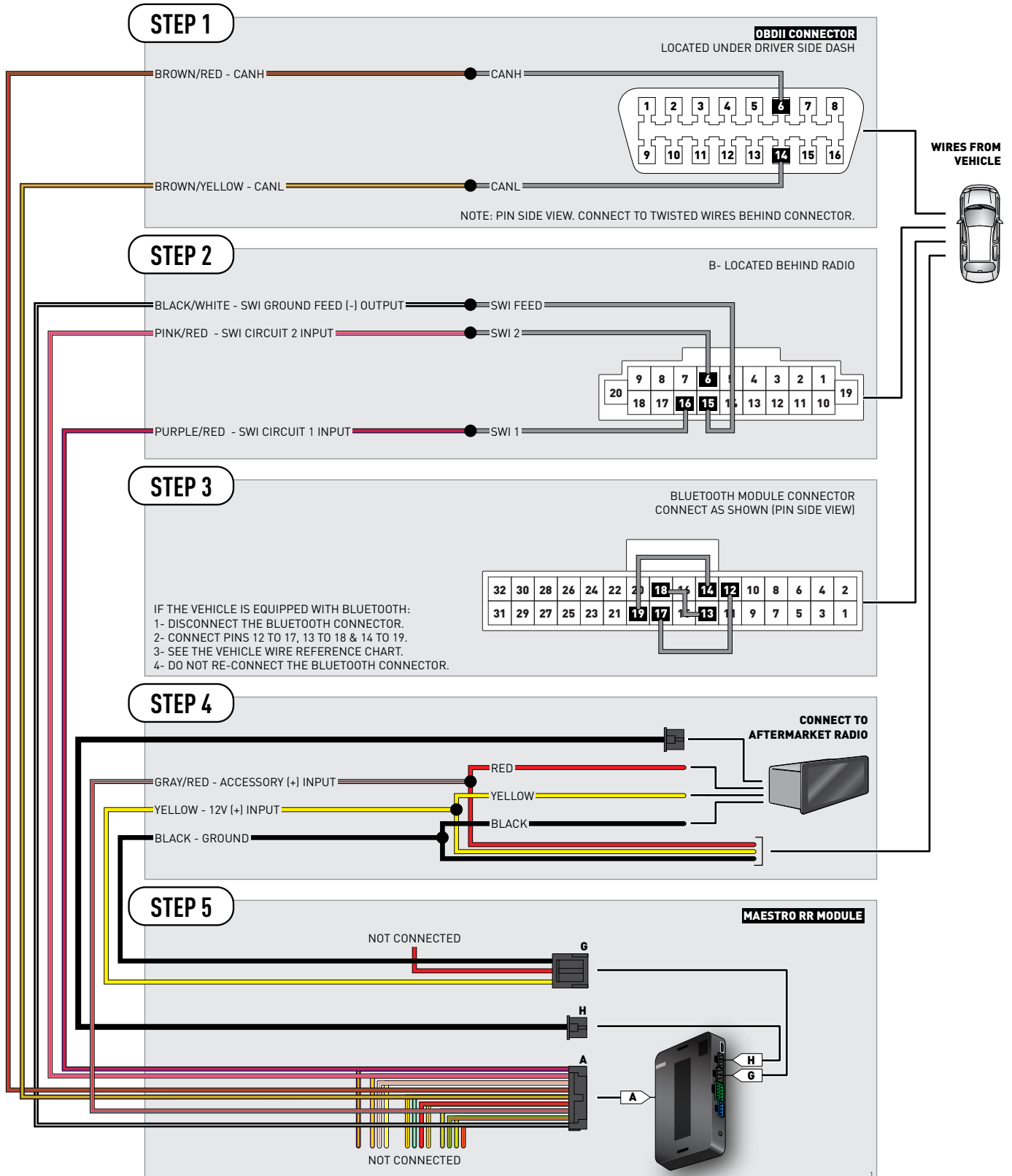

# VEHICLE WIRE REFERENCE CHART

Wire Description	Connector Name	Connector Color	Connector Type	Position	Wire Color	Polarity	Wire Location
CanH	A	~	16 pin	06	Blue	(DATA)	OBDII connector, under driver side dash
CanL	A	~	16 pin	14	Pink	(DATA)	OBDII connector, under driver side dash
SWI 1	B	~	20 pin	16	Gray/Black or LtGreen	(DATA)	Behind radio
SWI 2	B		20 pin	06	White/Blue or White	(DATA)	Behind radio
SWI Feed	B	~	20 pin	15	Blue/Green or Pink	(-)	Behind radio
BT-12	~	~	32 pin	12	Green	~	Behind glovebox, right side
BT-13	~	~	32 pin	13	Red	~	Behind glovebox, right side
BT-14	~	~	32 pin	14	Purple	~	Behind glovebox, right side
BT-17	~	~	32 pin	17	White/Blue or White	~	Behind glovebox, right side
BT-18	~	~	32 pin	18	Gray/Black or Green	~	Behind glovebox, right side
BT-19	~	~	32 pin	19	Blue/Green or Pink	~	Behind glovebox, right side

# iDatalink maestro *RR*

## INSTALL GUIDE NISSAN JUKE BLUETOOTH 2015-2017

RETAINS STEERING WHEEL CONTROLS AND ADDS GAUGES



### PRODUCTS REQUIRED

iDatalink Maestro RR Radio Replacement Interface  
iDatalink Compatible Radio

### PROGRAMMED FIRMWARE

ADS-RR(SI)-NIS01-DS

### OPTIONAL ACCESSORIES

**K40**<sup>™</sup>  
ELECTRONICS

Click here for:

[Radar Integration Installation Guide](#)

[Radar Integration Owner's Guide for Kenwood and JVC Radios](#)

# WELCOME

Congratulations on the purchase of your iDatalink Maestro RR Radio replacement solution. You are now a few simple steps away from enjoying your new car radio with enhanced features.

Before starting your installation, please ensure that your iDatalink Maestro module is programmed with the correct firmware for your vehicle and that you carefully review the install guide.

**Please note that Maestro RR will only retain functionalities that were originally available in the vehicle.**

# NEED HELP?

 **1 866 427-2999**

 [support@idatalink.com](mailto:support@idatalink.com)

 [maestro.idatalink.com/support](http://maestro.idatalink.com/support)  
[www.12voltdata.com/forum](http://www.12voltdata.com/forum)

## TABLE OF CONTENTS

Wiring Diagram	<b>3</b>
Vehicle Wire Reference Chart	<b>4</b>

# WIRING DIAGRAM

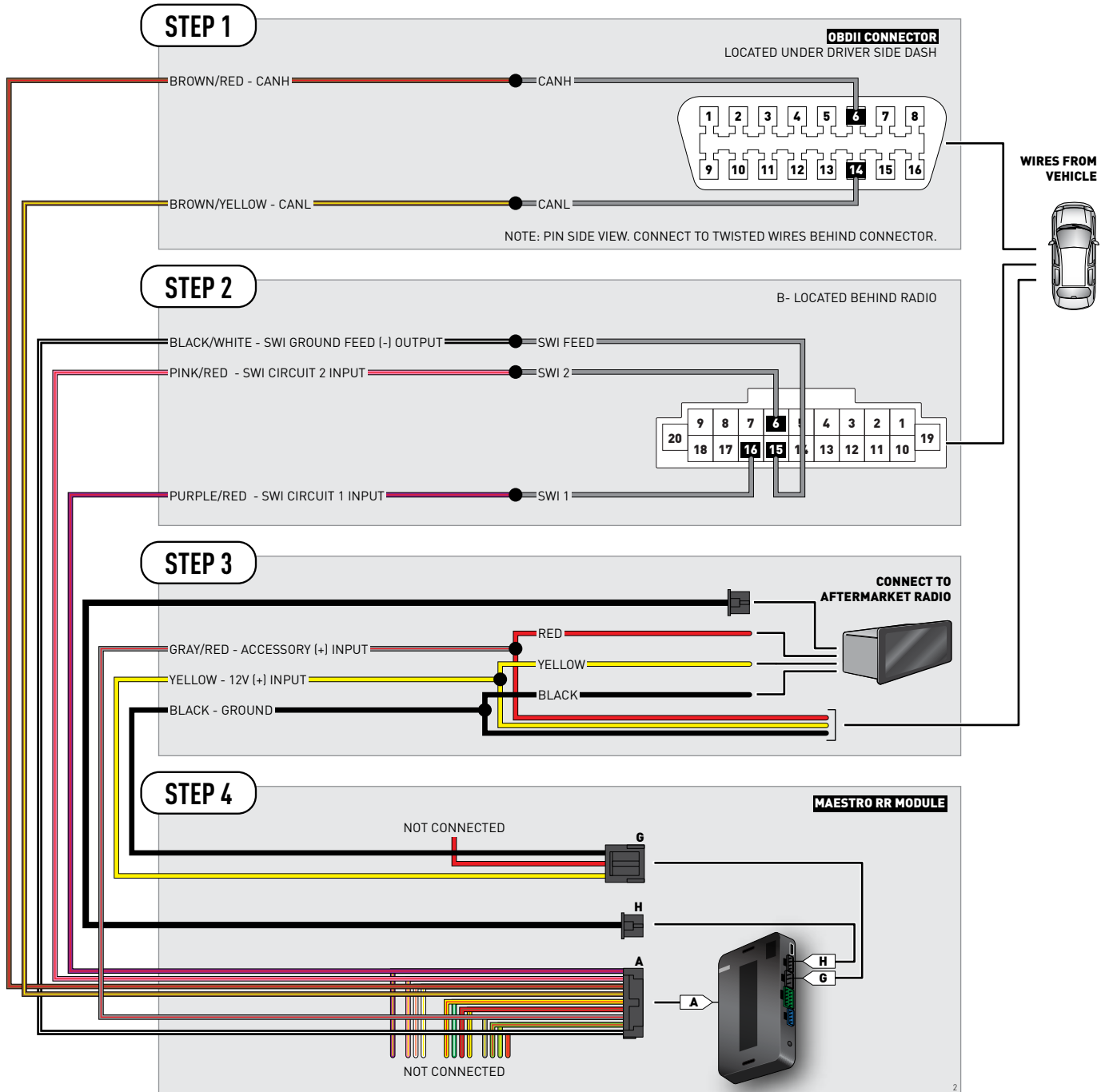



# VEHICLE WIRE REFERENCE CHART

Wire Description	Connector Name	Connector Color	Connector Type	Position	Wire Color	Polarity	Wire Location
CanH	A	~	16 pin	06	Blue	[DATA]	OBDII connector, under driver side dash
CanL	A	~	16 pin	14	Pink	[DATA]	OBDII connector, under driver side dash
SWI 1	B	~	20 pin	16	Red	[DATA]	Behind radio
SWI 2	B		20 pin	06	Green	[DATA]	Behind radio
SWI Feed	B	~	20 pin	15	Purple	(-)	Behind radio



# INSTALL GUIDE

# NISSAN JUKE

# NAV AND BLUETOOTH

# 2011-2017

RETAINS STEERING WHEEL CONTROLS AND ADDS GAUGES



#### PRODUCTS REQUIRED

iDatalink Maestro RR Radio Replacement Interface  
iDatalink Compatible Radio

#### PROGRAMMED FIRMWARE

ADS-RR(SI)-NIS01-DS

#### OPTIONAL ACCESSORIES



Click here for:

[Radar Integration Installation Guide](#)

[Radar Integration Owner's Guide for Kenwood and JVC Radios](#)

# WELCOME

Congratulations on the purchase of your iDatalink Maestro RR Radio replacement solution. You are now a few simple steps away from enjoying your new car radio with enhanced features.

Before starting your installation, please ensure that your iDatalink Maestro module is programmed with the correct firmware for your vehicle and that you carefully review the install guide.

**Please note that Maestro RR will only retain functionalities that were originally available in the vehicle.**

# NEED HELP?

 **1 866 427-2999**

 [support@idatalink.com](mailto:support@idatalink.com)

 [maestro.idatalink.com/support](http://maestro.idatalink.com/support)  
[www.12voltdata.com/forum](http://www.12voltdata.com/forum)

## TABLE OF CONTENTS

Wiring Diagram	<b>3</b>
Vehicle Wire Reference Chart	<b>4</b>

# WIRING DIAGRAM



# VEHICLE WIRE REFERENCE CHART

Wire Description	Connector Name	Connector Color	Connector Type	Position	Wire Color	Polarity	Wire Location
CanH	A	~	16 pin	06	Blue	[DATA]	OBDII connector, under driver side dash
CanL	A	~	16 pin	14	Pink	[DATA]	OBDII connector, under driver side dash
SWI 1	B	~	20 pin	16	Red	[DATA]	Behind radio
SWI 2	B		20 pin	06	Green	[DATA]	Behind radio
SWI Feed	B	~	20 pin	15	Purple	(-)	Behind radio



# INSTALL GUIDE NISSAN MAXIMA

## 2009-2010

RETAINS STEERING WHEEL CONTROLS AND ADDS GAUGES



### PRODUCTS REQUIRED

iDatalink Maestro RR Radio Replacement Interface  
iDatalink Compatible Radio

### PROGRAMMED FIRMWARE

ADS-RR(SI)-NIS01-DS

### OPTIONAL ACCESSORIES



Click here for:

[Radar Integration Installation Guide](#)

[Radar Integration Owner's Guide for Kenwood and JVC Radios](#)

# WELCOME

Congratulations on the purchase of your iDatalink Maestro RR Radio replacement solution. You are now a few simple steps away from enjoying your new car radio with enhanced features.

Before starting your installation, please ensure that your iDatalink Maestro module is programmed with the correct firmware for your vehicle and that you carefully review the install guide.

**Please note that Maestro RR will only retain functionalities that were originally available in the vehicle.**

# NEED HELP?

 **1 866 427-2999**

 [support@idatalink.com](mailto:support@idatalink.com)

 [maestro.idatalink.com/support](http://maestro.idatalink.com/support)  
[www.12voltdata.com/forum](http://www.12voltdata.com/forum)

## TABLE OF CONTENTS

Wiring Diagram	<b>3</b>
Vehicle Wire Reference Chart	<b>4</b>

# WIRING DIAGRAM

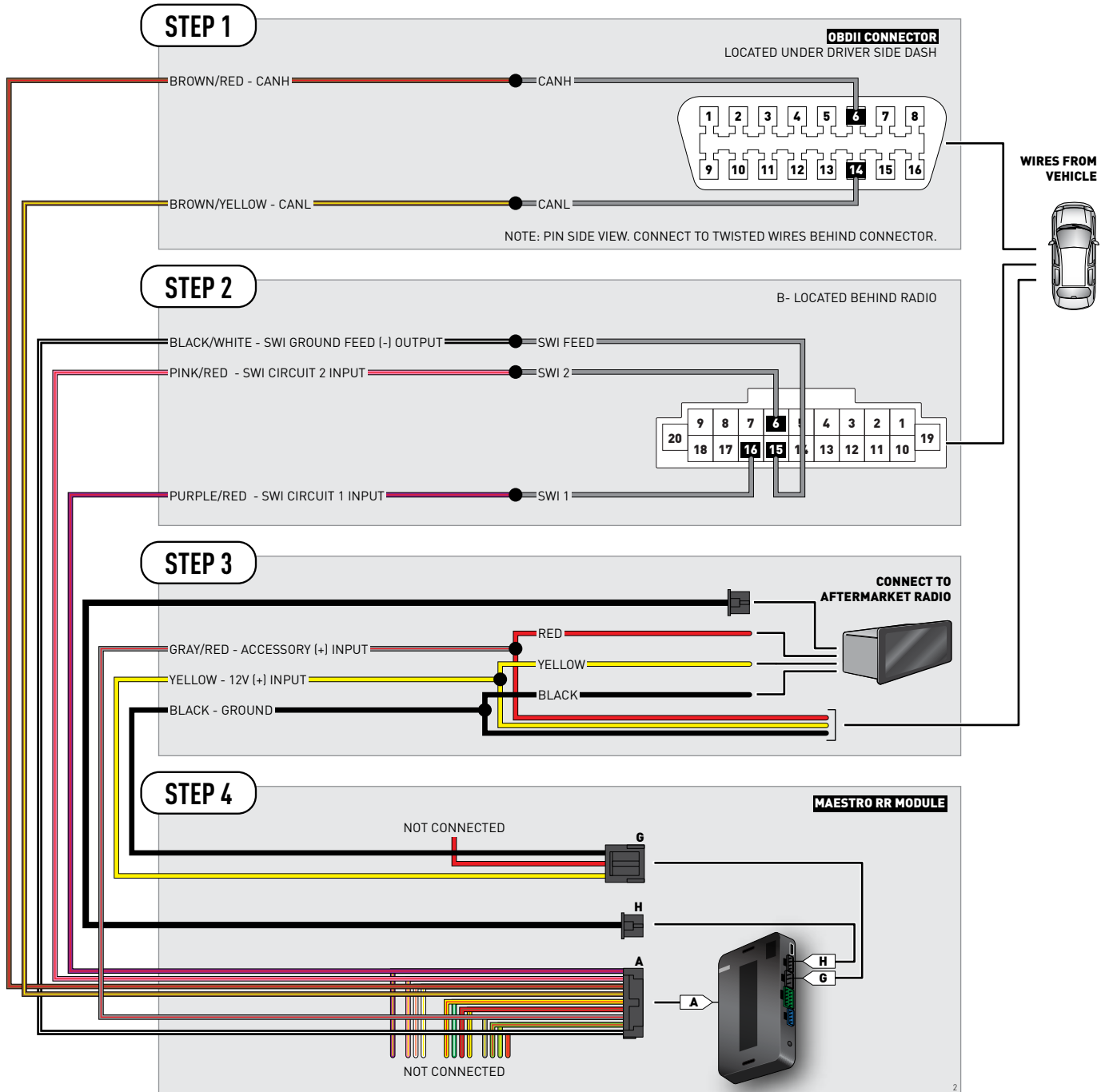



# VEHICLE WIRE REFERENCE CHART

Wire Description	Connector Name	Connector Color	Connector Type	Position	Wire Color	Polarity	Wire Location
CanH	A	~	16 pin	06	Blue	[DATA]	OBDII connector, under driver side dash
CanL	A	~	16 pin	14	Pink	[DATA]	OBDII connector, under driver side dash
SWI 1	B	~	20 pin	16	Gray/Blue	[DATA]	Behind radio
SWI 2	B		20 pin	06	White/Green	[DATA]	Behind radio
SWI Feed	B	~	20 pin	15	Blue/Black	(-)	Behind radio



# INSTALL GUIDE

# NISSAN MAXIMA

# BLUETOOTH

# 2011-2013

RETAINS STEERING WHEEL CONTROLS AND ADDS GAUGES



#### PRODUCTS REQUIRED

iDatalink Maestro RR Radio Replacement Interface  
iDatalink Compatible Radio

#### PROGRAMMED FIRMWARE

ADS-RR(SI)-NIS01-DS

#### OPTIONAL ACCESSORIES



Click here for:

[Radar Integration Installation Guide](#)

[Radar Integration Owner's Guide for Kenwood and JVC Radios](#)

# WELCOME

Congratulations on the purchase of your iDatalink Maestro RR Radio replacement solution. You are now a few simple steps away from enjoying your new car radio with enhanced features.

Before starting your installation, please ensure that your iDatalink Maestro module is programmed with the correct firmware for your vehicle and that you carefully review the install guide.

**Please note that Maestro RR will only retain functionalities that were originally available in the vehicle.**

# NEED HELP?

 **1 866 427-2999**

 [support@idatalink.com](mailto:support@idatalink.com)

 [maestro.idatalink.com/support](http://maestro.idatalink.com/support)  
[www.12voltdata.com/forum](http://www.12voltdata.com/forum)

## TABLE OF CONTENTS

Wiring Diagram	<b>3</b>
Vehicle Wire Reference Chart	<b>4</b>

# WIRING DIAGRAM

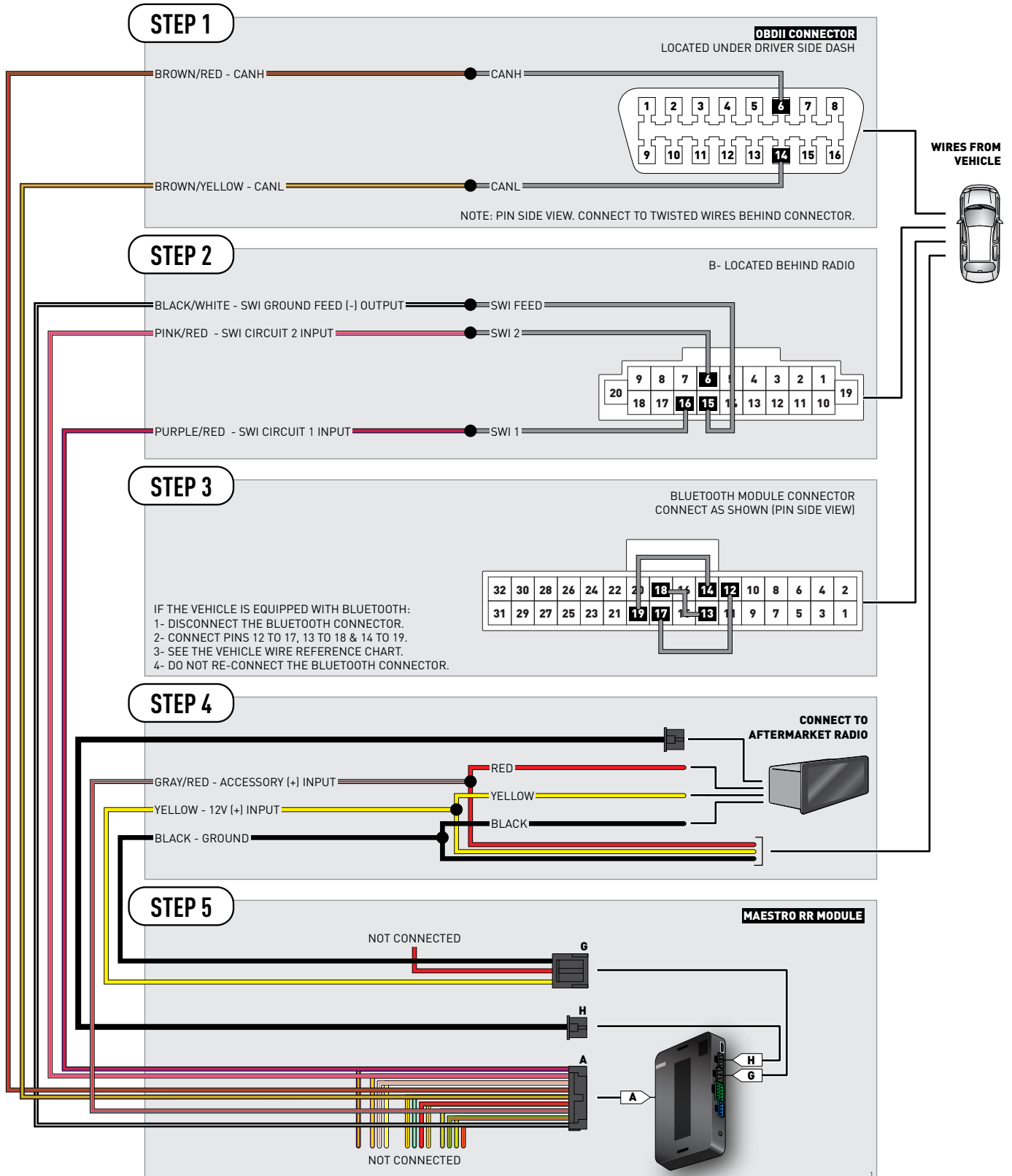

# VEHICLE WIRE REFERENCE CHART

Wire Description	Connector Name	Connector Color	Connector Type	Position	Wire Color	Polarity	Wire Location
CanH	A	~	16 pin	06	Blue	(DATA)	OBDII connector, under driver side dash
CanL	A	~	16 pin	14	Pink	(DATA)	OBDII connector, under driver side dash
SWI 1	B	~	20 pin	16	Gray/Blue	(DATA)	Behind radio
SWI 2	B		20 pin	06	White/Green	(DATA)	Behind radio
SWI Feed	B	~	20 pin	15	Blue/Black	(-)	Behind radio
BT-12	~	~	32 pin	12	Blue	~	Trunk, under center shelf
BT-13	~	~	32 pin	13	Pink	~	Trunk, under center shelf
BT-14	~	~	32 pin	14	Red	~	Trunk, under center shelf
BT-17	~	~	32 pin	17	Green	~	Trunk, under center shelf
BT-18	~	~	32 pin	18	White	~	Trunk, under center shelf
BT-19	~	~	32 pin	19	LtGreen	~	Trunk, under center shelf



# INSTALL GUIDE

# NISSAN MAXIMA

# NAV AND BLUETOOTH

# 2011-2013

RETAINS STEERING WHEEL CONTROLS AND ADDS GAUGES



#### PRODUCTS REQUIRED

iDatalink Maestro RR Radio Replacement Interface  
iDatalink Compatible Radio

#### PROGRAMMED FIRMWARE

ADS-RR(SI)-NIS01-DS

#### OPTIONAL ACCESSORIES



Click here for:

[Radar Integration Installation Guide](#)

[Radar Integration Owner's Guide for Kenwood and JVC Radios](#)

# WELCOME

Congratulations on the purchase of your iDatalink Maestro RR Radio replacement solution. You are now a few simple steps away from enjoying your new car radio with enhanced features.

Before starting your installation, please ensure that your iDatalink Maestro module is programmed with the correct firmware for your vehicle and that you carefully review the install guide.

**Please note that Maestro RR will only retain functionalities that were originally available in the vehicle.**

# NEED HELP?

 **1 866 427-2999**

 [support@idatalink.com](mailto:support@idatalink.com)

 [maestro.idatalink.com/support](http://maestro.idatalink.com/support)  
[www.12voltdata.com/forum](http://www.12voltdata.com/forum)

## TABLE OF CONTENTS

Wiring Diagram	<b>3</b>
Vehicle Wire Reference Chart	<b>4</b>

# WIRING DIAGRAM

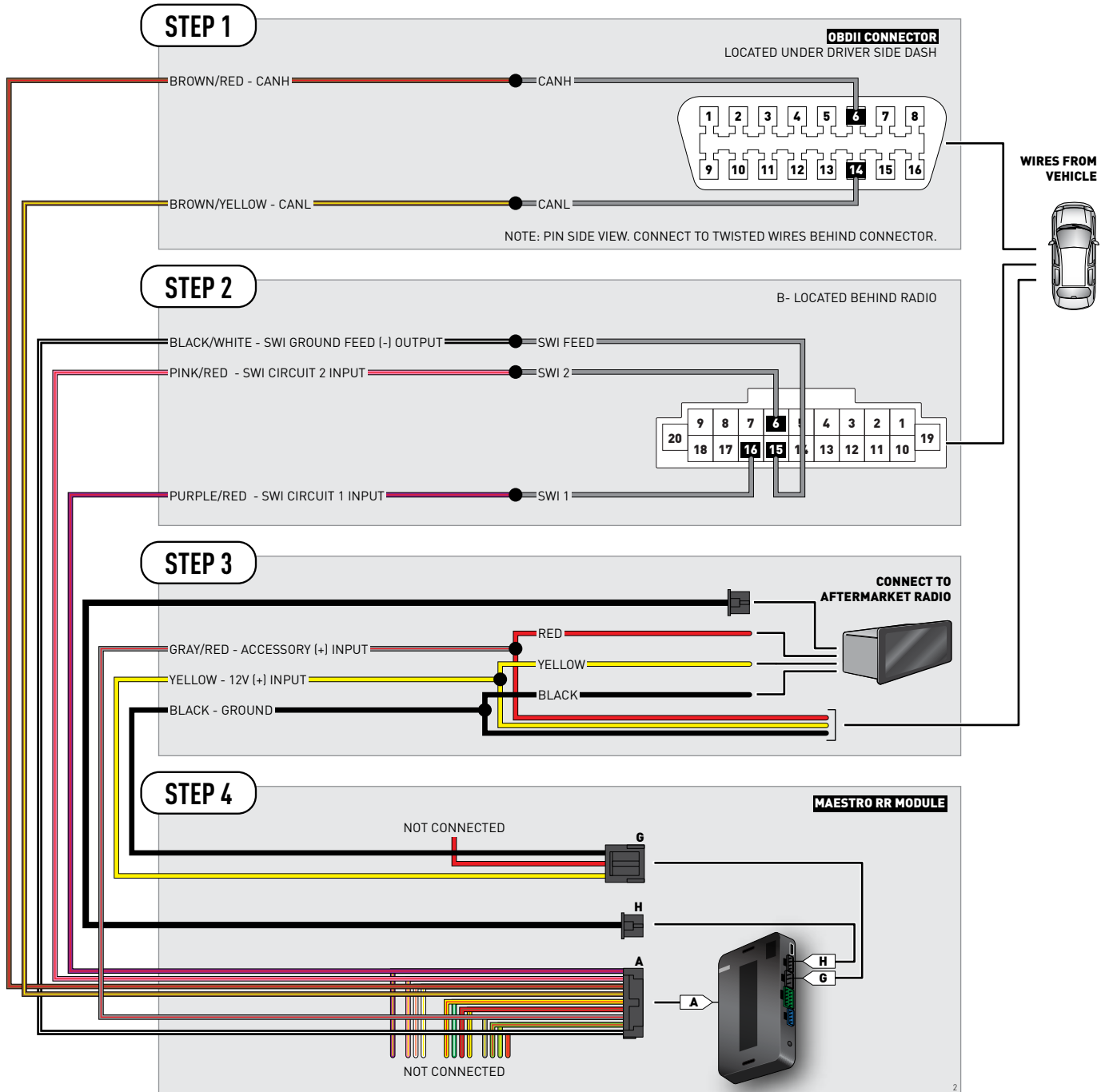



# VEHICLE WIRE REFERENCE CHART

Wire Description	Connector Name	Connector Color	Connector Type	Position	Wire Color	Polarity	Wire Location
CanH	A	~	16 pin	06	Blue	[DATA]	OBDII connector, under driver side dash
CanL	A	~	16 pin	14	Pink	[DATA]	OBDII connector, under driver side dash
SWI 1	B	~	20 pin	16	Gray/Blue	[DATA]	Behind radio
SWI 2	B		20 pin	06	White/Green	[DATA]	Behind radio
SWI Feed	B	~	20 pin	15	Blue/Black	(-)	Behind radio



# INSTALL GUIDE

# NISSAN MAXIMA

# WITH BOSE COLOR DISPLAY

# 2011-2013

RETAINS STEERING WHEEL CONTROLS AND ADDS GAUGES



#### PRODUCTS REQUIRED

iDatalink Maestro RR Radio Replacement Interface  
iDatalink Compatible Radio

#### PROGRAMMED FIRMWARE

ADS-RR(SI)-NIS01-DS

#### OPTIONAL ACCESSORIES



Click here for:

[Radar Integration Installation Guide](#)

[Radar Integration Owner's Guide for Kenwood and JVC Radios](#)

# WELCOME

Congratulations on the purchase of your iDatalink Maestro RR Radio replacement solution. You are now a few simple steps away from enjoying your new car radio with enhanced features.

Before starting your installation, please ensure that your iDatalink Maestro module is programmed with the correct firmware for your vehicle and that you carefully review the install guide.

**Please note that Maestro RR will only retain functionalities that were originally available in the vehicle.**

# NEED HELP?

 **1 866 427-2999**

 **[support@idatalink.com](mailto:support@idatalink.com)**

 **[maestro.idatalink.com/support](http://maestro.idatalink.com/support)  
[www.12voltdata.com/forum](http://www.12voltdata.com/forum)**

## TABLE OF CONTENTS

Wiring Diagram	<b>3</b>
Vehicle Wire Reference Chart	<b>4</b>

# WIRING DIAGRAM



# VEHICLE WIRE REFERENCE CHART

Wire Description	Connector Name	Connector Color	Connector Type	Position	Wire Color	Polarity	Wire Location
CanH	A	~	16 pin	06	Blue	[DATA]	OBDII connector, under driver side dash
CanL	A	~	16 pin	14	Pink	[DATA]	OBDII connector, under driver side dash
SWI 1	B	~	20 pin	16	Gray/Blue	[DATA]	Behind radio
SWI 2	B		20 pin	06	White/Green	[DATA]	Behind radio
SWI Feed	B	~	20 pin	15	Blue/Black	(-)	Behind radio



# INSTALL GUIDE

# NISSAN MAXIMA

# WITH BOSE MONOCHROME DISPLAY

# 2011-2013

RETAINS STEERING WHEEL CONTROLS AND ADDS GAUGES



#### PRODUCTS REQUIRED

iDatalink Maestro RR Radio Replacement Interface  
iDatalink Compatible Radio

#### PROGRAMMED FIRMWARE

ADS-RR(SI)-NIS01-DS

#### OPTIONAL ACCESSORIES



Click here for:

[Radar Integration Installation Guide](#)

[Radar Integration Owner's Guide for Kenwood and JVC Radios](#)

# WELCOME

Congratulations on the purchase of your iDatalink Maestro RR Radio replacement solution. You are now a few simple steps away from enjoying your new car radio with enhanced features.

Before starting your installation, please ensure that your iDatalink Maestro module is programmed with the correct firmware for your vehicle and that you carefully review the install guide.

**Please note that Maestro RR will only retain functionalities that were originally available in the vehicle.**

# NEED HELP?

 **1 866 427-2999**

 [support@idatalink.com](mailto:support@idatalink.com)

 [maestro.idatalink.com/support](http://maestro.idatalink.com/support)  
[www.12voltdata.com/forum](http://www.12voltdata.com/forum)

## TABLE OF CONTENTS

Wiring Diagram	<b>3</b>
Vehicle Wire Reference Chart	<b>4</b>

# WIRING DIAGRAM

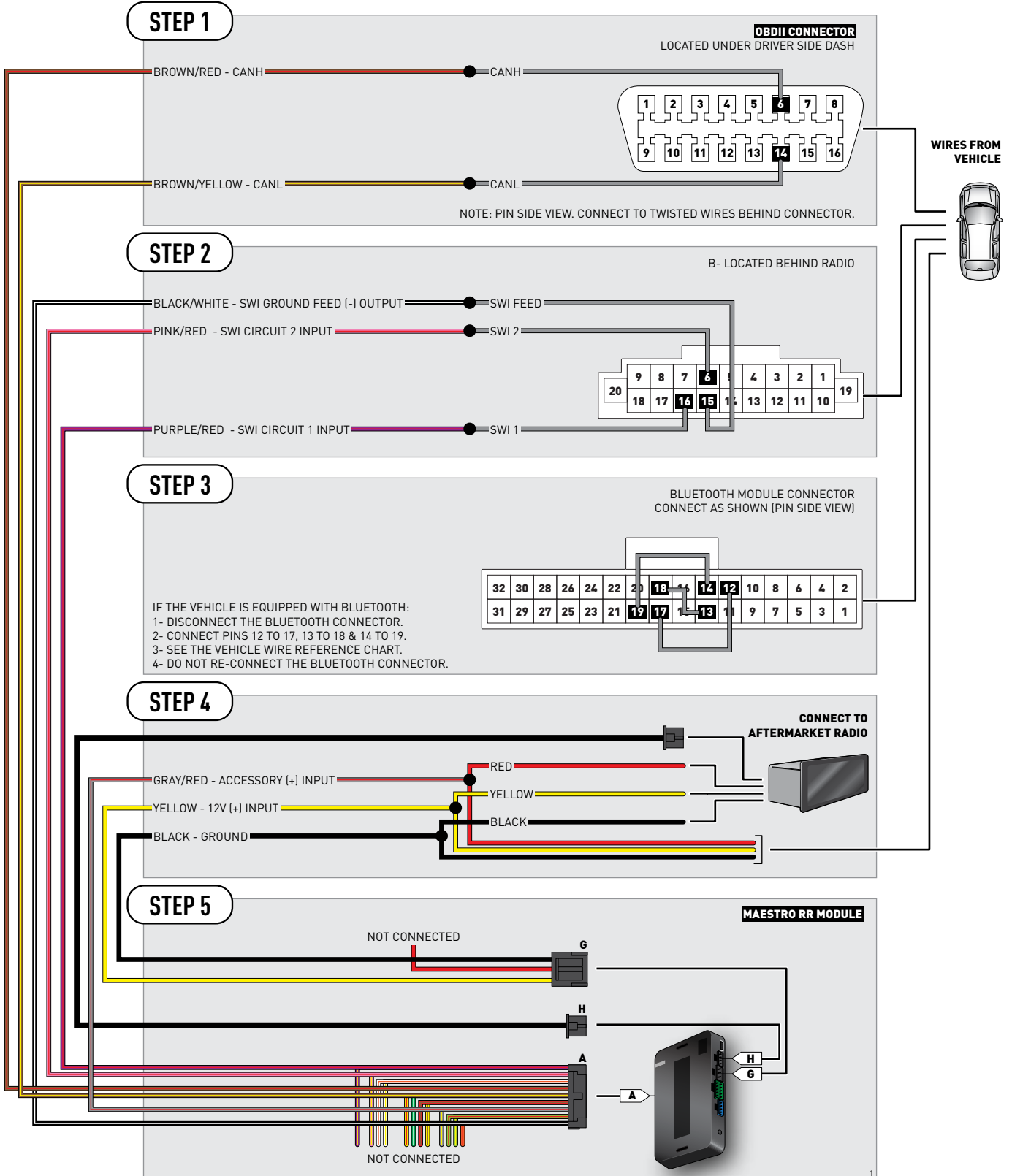



# VEHICLE WIRE REFERENCE CHART

Wire Description	Connector Name	Connector Color	Connector Type	Position	Wire Color	Polarity	Wire Location
CanH	A	~	16 pin	06	Blue	(DATA)	OBDII connector, under driver side dash
CanL	A	~	16 pin	14	Pink	(DATA)	OBDII connector, under driver side dash
SWI 1	B	~	20 pin	16	Gray/Blue	(DATA)	Behind radio
SWI 2	B		20 pin	06	White/Green	(DATA)	Behind radio
SWI Feed	B	~	20 pin	15	Blue/Black	(-)	Behind radio
BT-12	~	~	32 pin	12	Blue	~	Trunk, under center shelf
BT-13	~	~	32 pin	13	Pink	~	Trunk, under center shelf
BT-14	~	~	32 pin	14	Red	~	Trunk, under center shelf
BT-17	~	~	32 pin	17	Green	~	Trunk, under center shelf
BT-18	~	~	32 pin	18	White	~	Trunk, under center shelf
BT-19	~	~	32 pin	19	LtGreen	~	Trunk, under center shelf



# INSTALL GUIDE NISSAN MURANO

## 2009-2014

RETAINS STEERING WHEEL CONTROLS AND ADDS GAUGES



### PRODUCTS REQUIRED

iDatalink Maestro RR Radio Replacement Interface  
iDatalink Compatible Radio

### PROGRAMMED FIRMWARE

ADS-RR(SI)-NIS01-DS

### OPTIONAL ACCESSORIES



Click here for:

[Radar Integration Installation Guide](#)

[Radar Integration Owner's Guide for Kenwood and JVC Radios](#)

# WELCOME

Congratulations on the purchase of your iDatalink Maestro RR Radio replacement solution. You are now a few simple steps away from enjoying your new car radio with enhanced features.

Before starting your installation, please ensure that your iDatalink Maestro module is programmed with the correct firmware for your vehicle and that you carefully review the install guide.

**Please note that Maestro RR will only retain functionalities that were originally available in the vehicle.**

# NEED HELP?

 **1 866 427-2999**

 **[support@idatalink.com](mailto:support@idatalink.com)**

 **[maestro.idatalink.com/support](http://maestro.idatalink.com/support)  
[www.12voltdata.com/forum](http://www.12voltdata.com/forum)**

## TABLE OF CONTENTS

Wiring Diagram	<b>3</b>
Vehicle Wire Reference Chart	<b>4</b>

# WIRING DIAGRAM



# VEHICLE WIRE REFERENCE CHART

Wire Description	Connector Name	Connector Color	Connector Type	Position	Wire Color	Polarity	Wire Location
CanH	A	~	16 pin	07	Blue	(DATA)	OBDII connector, under driver side dash
CanL	A	~	16 pin	14	Pink	(DATA)	OBDII connector, under driver side dash
SWI 1	B	~	20 pin	16	Yellow or Green	(DATA)	Behind radio
SWI 2	B		20 pin	06	White or Brown	(DATA)	Behind radio
SWI Feed	B	~	20 pin	15	LtBlue or Blue	(-)	Behind radio



# INSTALL GUIDE

# NISSAN NV1500 2500 3500

# BASE

# 2012-2018

RETAINS STEERING WHEEL CONTROLS AND ADDS GAUGES



#### PRODUCTS REQUIRED

iDatalink Maestro RR Radio Replacement Interface  
iDatalink Compatible Radio

#### PROGRAMMED FIRMWARE

ADS-RR(SI)-NIS01-DS

#### OPTIONAL ACCESSORIES



Click here for:

[Radar Integration Installation Guide](#)

[Radar Integration Owner's Guide for Kenwood and JVC Radios](#)

# WELCOME

Congratulations on the purchase of your iDatalink Maestro RR Radio replacement solution. You are now a few simple steps away from enjoying your new car radio with enhanced features.

Before starting your installation, please ensure that your iDatalink Maestro module is programmed with the correct firmware for your vehicle and that you carefully review the install guide.

**Please note that Maestro RR will only retain functionalities that were originally available in the vehicle.**

# NEED HELP?

 **1 866 427-2999**

 [support@idatalink.com](mailto:support@idatalink.com)

 [maestro.idatalink.com/support](http://maestro.idatalink.com/support)  
[www.12voltdata.com/forum](http://www.12voltdata.com/forum)

## TABLE OF CONTENTS

Wiring Diagram	<b>3</b>
Vehicle Wire Reference Chart	<b>4</b>

# WIRING DIAGRAM

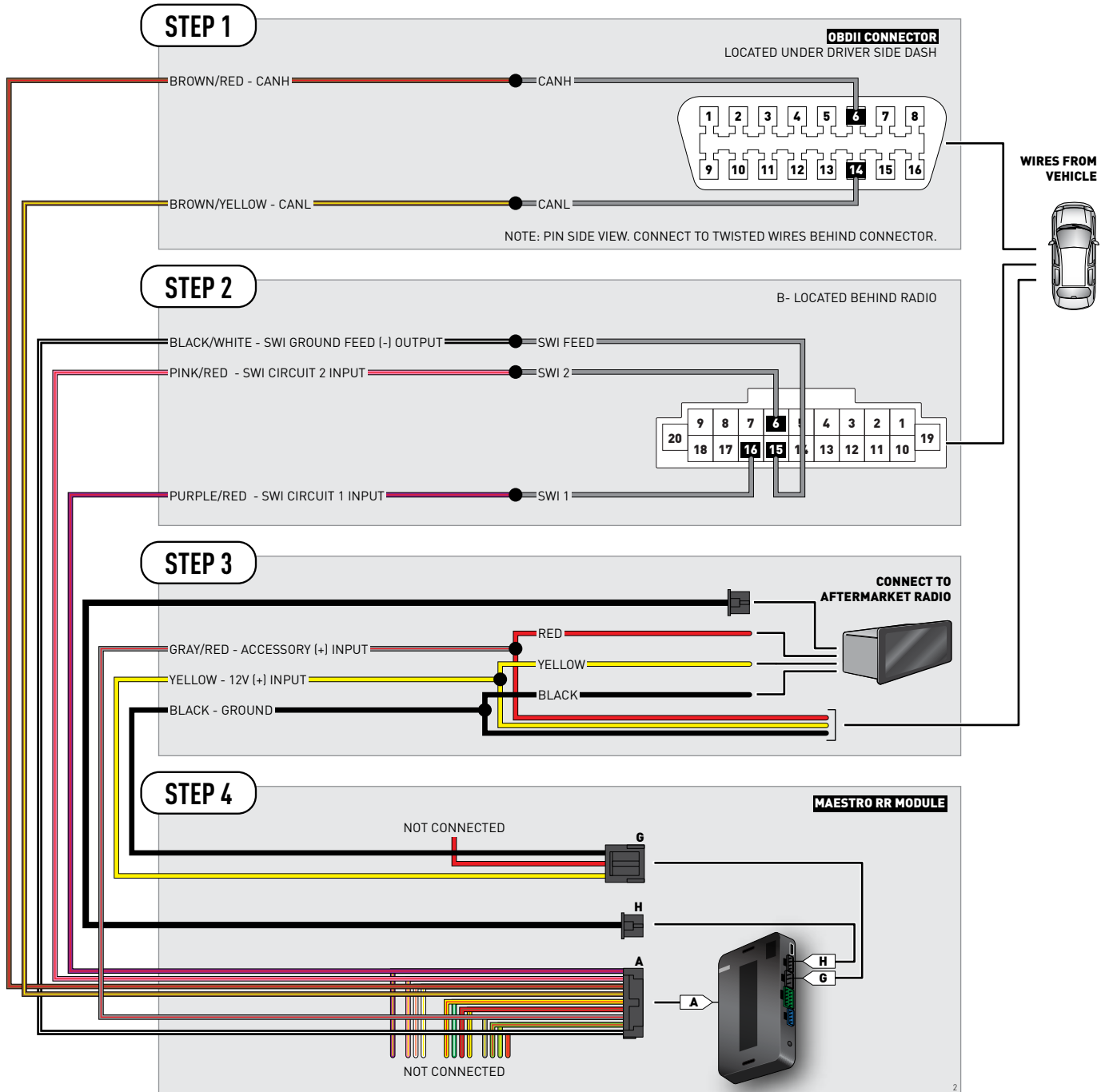



# VEHICLE WIRE REFERENCE CHART

Wire Description	Connector Name	Connector Color	Connector Type	Position	Wire Color	Polarity	Wire Location
CanH	A	~	16 pin	06	Blue	[DATA]	OBDII connector, under driver side dash
CanL	A	~	16 pin	14	Pink	[DATA]	OBDII connector, under driver side dash
SWI 1	B	~	20 pin	16	White	[DATA]	Behind radio
SWI 2	B		20 pin	06	Yellow	[DATA]	Behind radio
SWI Feed	B	~	20 pin	15	Brown	(-)	Behind radio



# INSTALL GUIDE

# NISSAN NV1500 2500 3500

# BLUETOOTH

# 2012-2018

RETAINS STEERING WHEEL CONTROLS AND ADDS GAUGES



#### PRODUCTS REQUIRED

iDatalink Maestro RR Radio Replacement Interface  
iDatalink Compatible Radio

#### PROGRAMMED FIRMWARE

ADS-RR(SI)-NIS01-DS

#### OPTIONAL ACCESSORIES



Click here for:

[Radar Integration Installation Guide](#)

[Radar Integration Owner's Guide for Kenwood and JVC Radios](#)

# WELCOME

Congratulations on the purchase of your iDatalink Maestro RR Radio replacement solution. You are now a few simple steps away from enjoying your new car radio with enhanced features.

Before starting your installation, please ensure that your iDatalink Maestro module is programmed with the correct firmware for your vehicle and that you carefully review the install guide.

**Please note that Maestro RR will only retain functionalities that were originally available in the vehicle.**

# NEED HELP?

 **1 866 427-2999**

 [support@idatalink.com](mailto:support@idatalink.com)

 [maestro.idatalink.com/support](http://maestro.idatalink.com/support)  
[www.12voltdata.com/forum](http://www.12voltdata.com/forum)

## TABLE OF CONTENTS

Wiring Diagram	<b>3</b>
Vehicle Wire Reference Chart	<b>4</b>

# WIRING DIAGRAM

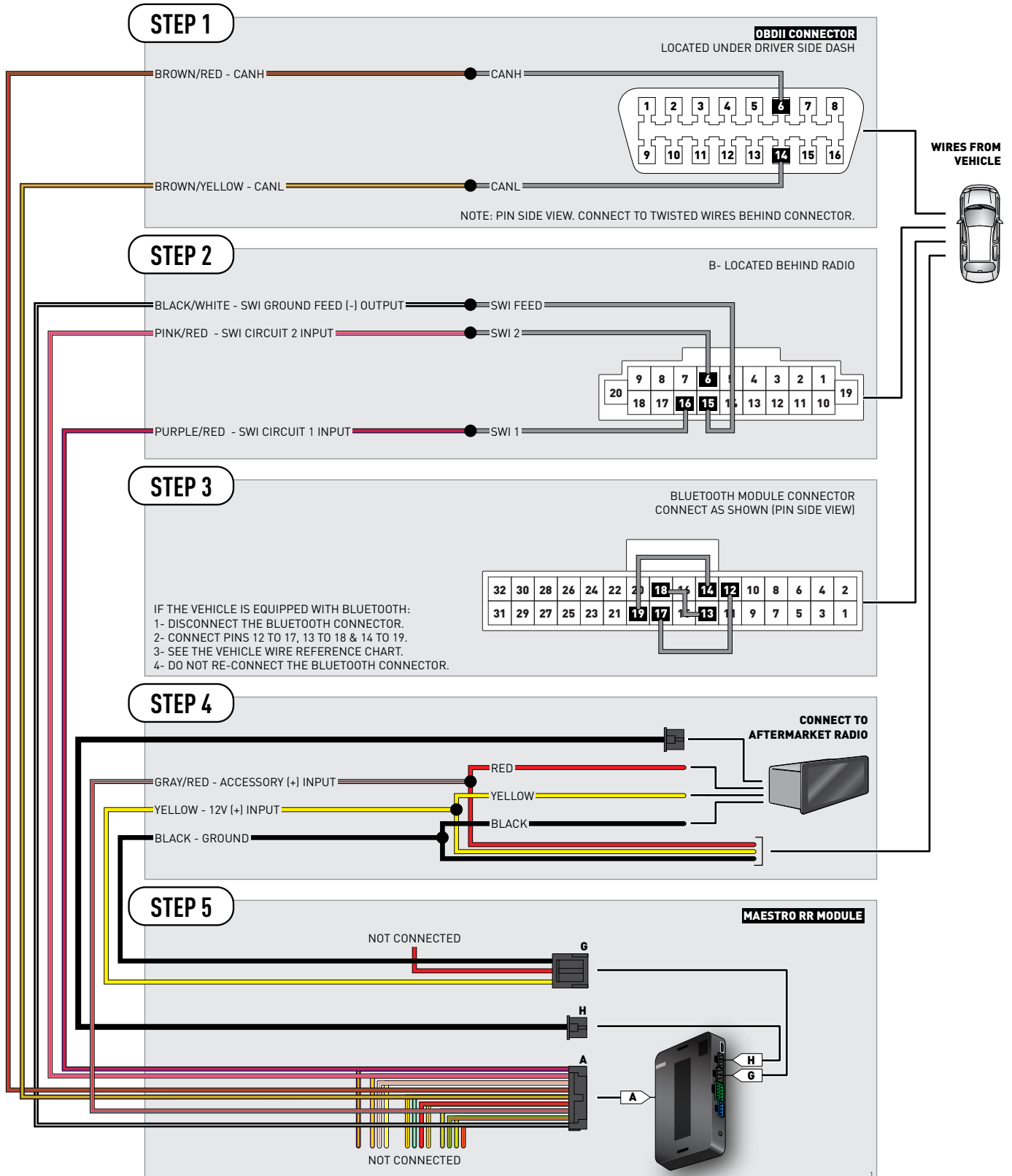

# VEHICLE WIRE REFERENCE CHART

Wire Description	Connector Name	Connector Color	Connector Type	Position	Wire Color	Polarity	Wire Location
CanH	A	~	16 pin	06	Blue	(DATA)	OBDII connector, under driver side dash
CanL	A	~	16 pin	14	Pink	(DATA)	OBDII connector, under driver side dash
SWI 1	B	~	20 pin	16	White	(DATA)	Behind radio
SWI 2	B		20 pin	06	Yellow	(DATA)	Behind radio
SWI Feed	B	~	20 pin	15	Brown	(-)	Behind radio
BT-12	~	~	32 pin	12	LtBlue	~	Behind center dash, under radio
BT-13	~	~	32 pin	13	Gray	~	Behind center dash, under radio
BT-14	~	~	32 pin	14	LtGreen	~	Behind center dash, under radio
BT-17	~	~	32 pin	17	Yellow	~	Behind center dash, under radio
BT-18	~	~	32 pin	18	White	~	Behind center dash, under radio
BT-19	~	~	32 pin	19	Brown	~	Behind center dash, under radio



# INSTALL GUIDE

# NISSAN NV1500 2500 3500

# NAV AND BLUETOOTH

# 2012-2018

RETAINS STEERING WHEEL CONTROLS AND ADDS GAUGES



#### PRODUCTS REQUIRED

iDatalink Maestro RR Radio Replacement Interface  
iDatalink Compatible Radio

#### PROGRAMMED FIRMWARE

ADS-RR(SI)-NIS01-DS

#### OPTIONAL ACCESSORIES



Click here for:

[Radar Integration Installation Guide](#)

[Radar Integration Owner's Guide for Kenwood and JVC Radios](#)

# WELCOME

Congratulations on the purchase of your iDatalink Maestro RR Radio replacement solution. You are now a few simple steps away from enjoying your new car radio with enhanced features.

Before starting your installation, please ensure that your iDatalink Maestro module is programmed with the correct firmware for your vehicle and that you carefully review the install guide.

**Please note that Maestro RR will only retain functionalities that were originally available in the vehicle.**

# NEED HELP?

 **1 866 427-2999**

 [support@idatalink.com](mailto:support@idatalink.com)

 [maestro.idatalink.com/support](http://maestro.idatalink.com/support)  
[www.12voltdata.com/forum](http://www.12voltdata.com/forum)

## TABLE OF CONTENTS

Wiring Diagram	3
Vehicle Wire Reference Chart	4

# WIRING DIAGRAM

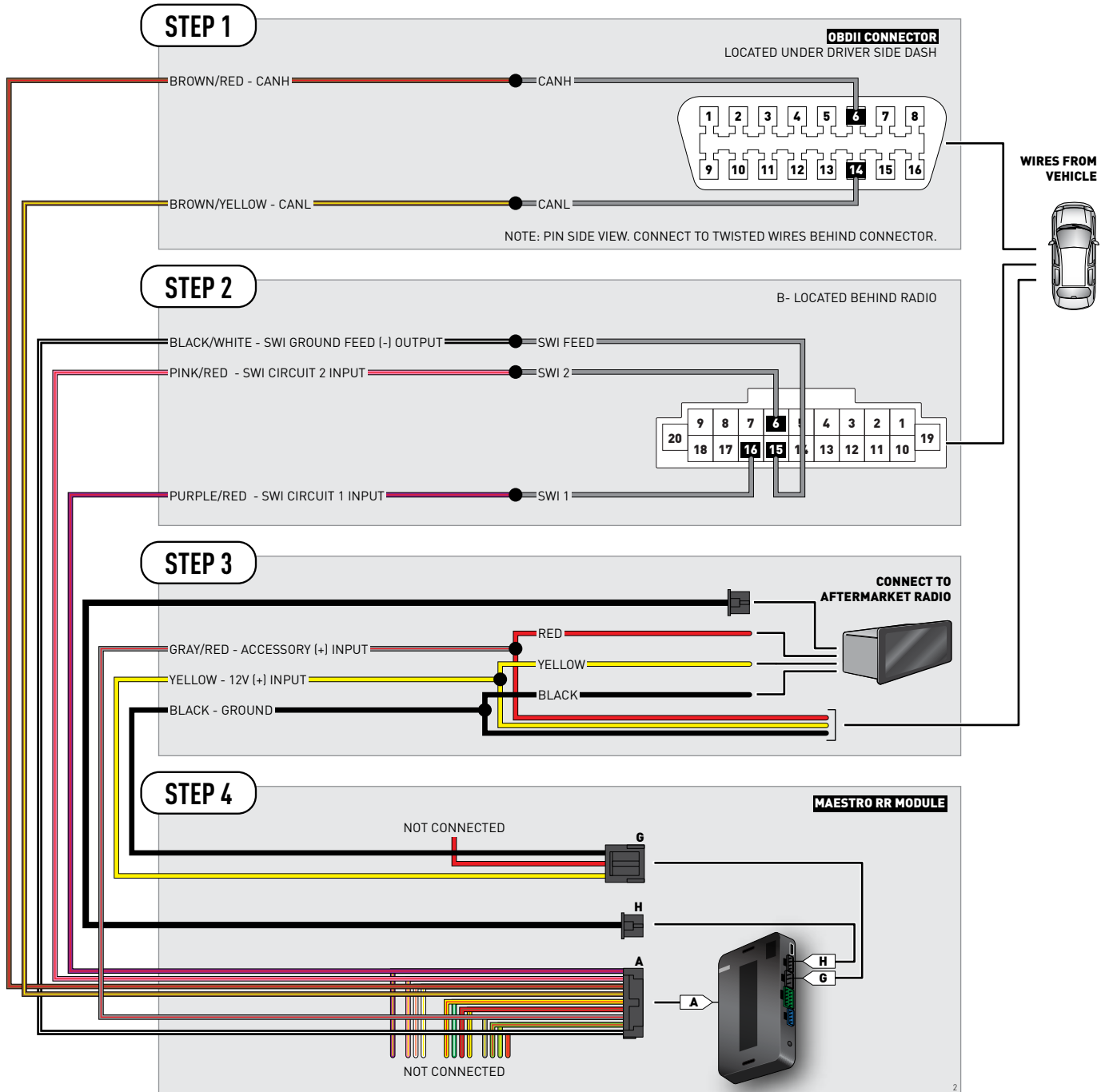



# VEHICLE WIRE REFERENCE CHART

Wire Description	Connector Name	Connector Color	Connector Type	Position	Wire Color	Polarity	Wire Location
CanH	A	~	16 pin	06	Blue	[DATA]	OBDII connector, under driver side dash
CanL	A	~	16 pin	14	Pink	[DATA]	OBDII connector, under driver side dash
SWI 1	B	~	20 pin	16	Gray	[DATA]	Behind radio
SWI 2	B		20 pin	06	LtBlue	[DATA]	Behind radio
SWI Feed	B	~	20 pin	15	Green	(-)	Behind radio



# INSTALL GUIDE NISSAN NV200 BLUETOOTH 2013-2018

RETAINS STEERING WHEEL CONTROLS AND ADDS GAUGES



#### PRODUCTS REQUIRED

iDatalink Maestro RR Radio Replacement Interface  
iDatalink Compatible Radio

#### PROGRAMMED FIRMWARE

ADS-RR(SI)-NIS01-DS

#### OPTIONAL ACCESSORIES



Click here for:

[Radar Integration Installation Guide](#)

[Radar Integration Owner's Guide for Kenwood and JVC Radios](#)

# WELCOME

Congratulations on the purchase of your iDatalink Maestro RR Radio replacement solution. You are now a few simple steps away from enjoying your new car radio with enhanced features.

Before starting your installation, please ensure that your iDatalink Maestro module is programmed with the correct firmware for your vehicle and that you carefully review the install guide.

**Please note that Maestro RR will only retain functionalities that were originally available in the vehicle.**

# NEED HELP?

 **1 866 427-2999**

 **[support@idatalink.com](mailto:support@idatalink.com)**

 **[maestro.idatalink.com/support](http://maestro.idatalink.com/support)  
[www.12voltdata.com/forum](http://www.12voltdata.com/forum)**

## TABLE OF CONTENTS

Wiring Diagram	<b>3</b>
Vehicle Wire Reference Chart	<b>4</b>

# WIRING DIAGRAM

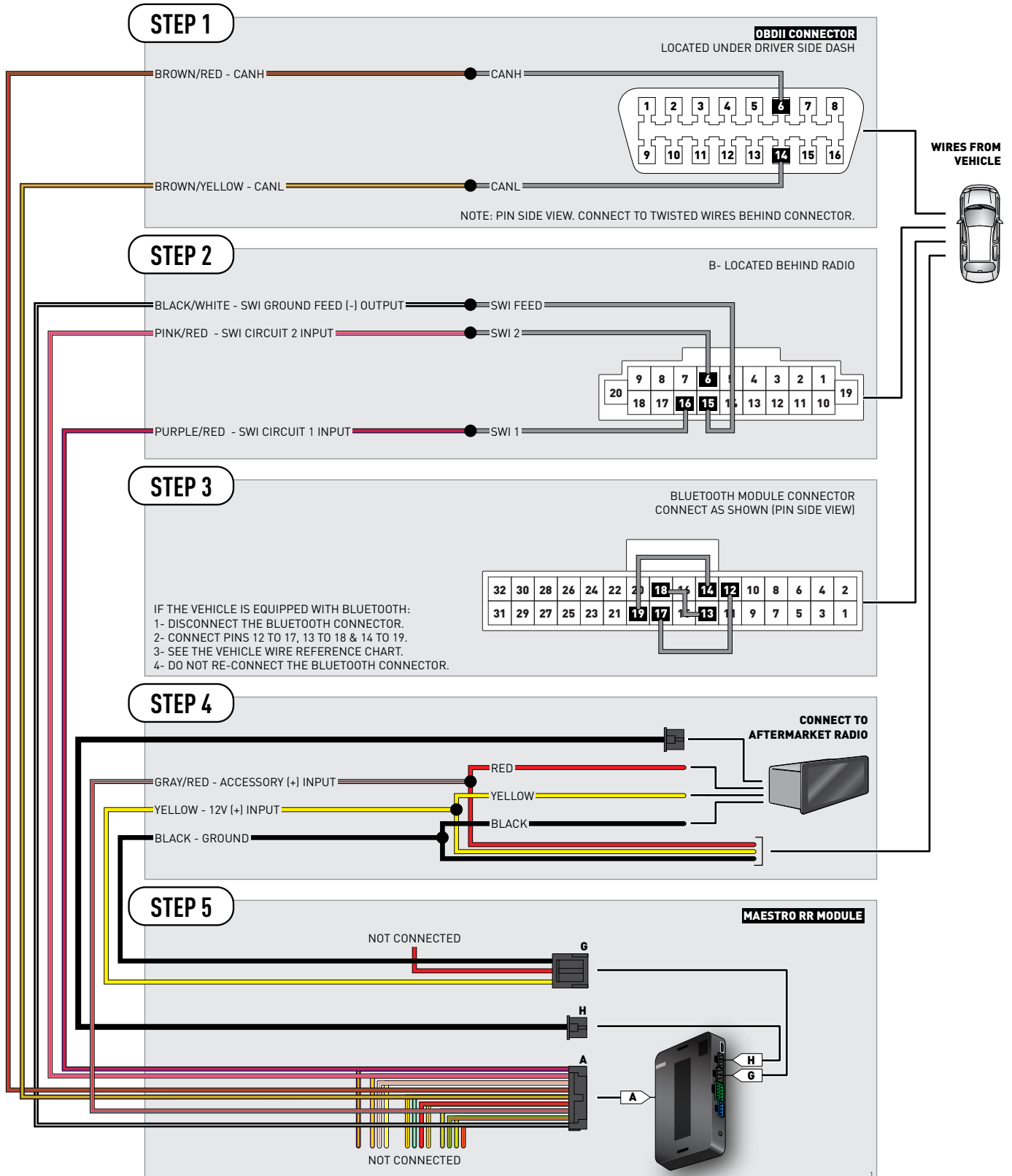

# VEHICLE WIRE REFERENCE CHART

Wire Description	Connector Name	Connector Color	Connector Type	Position	Wire Color	Polarity	Wire Location
CanH	A	~	16 pin	06	Blue	(DATA)	OBDII connector, under driver side dash
CanL	A	~	16 pin	14	Pink	(DATA)	OBDII connector, under driver side dash
SWI 1	B	~	20 pin	16	Yellow	(DATA)	Behind radio
SWI 2	B		20 pin	06	LtGreen	(DATA)	Behind radio
SWI Feed	B	~	20 pin	15	Black	(-)	Behind radio
BT-12	~	~	32 pin	12	Brown	~	Behind center dash, under radio
BT-13	~	~	32 pin	13	Yellow	~	Behind center dash, under radio
BT-14	~	~	32 pin	14	Bare	~	Behind center dash, under radio
BT-17	~	~	32 pin	17	LtGreen	~	Behind center dash, under radio
BT-18	~	~	32 pin	18	Yellow	~	Behind center dash, under radio
BT-19	~	~	32 pin	19	Black	~	Behind center dash, under radio



# INSTALL GUIDE

# NISSAN NV200

# NAV AND BLUETOOTH

# 2013-2018

RETAINS STEERING WHEEL CONTROLS AND ADDS GAUGES



#### PRODUCTS REQUIRED

iDatalink Maestro RR Radio Replacement Interface  
iDatalink Compatible Radio

#### PROGRAMMED FIRMWARE

ADS-RR(SI)-NIS01-DS

#### OPTIONAL ACCESSORIES



Click here for:

[Radar Integration Installation Guide](#)

[Radar Integration Owner's Guide for Kenwood and JVC Radios](#)

# WELCOME

Congratulations on the purchase of your iDatalink Maestro RR Radio replacement solution. You are now a few simple steps away from enjoying your new car radio with enhanced features.

Before starting your installation, please ensure that your iDatalink Maestro module is programmed with the correct firmware for your vehicle and that you carefully review the install guide.

**Please note that Maestro RR will only retain functionalities that were originally available in the vehicle.**

# NEED HELP?

 **1 866 427-2999**

 [support@idatalink.com](mailto:support@idatalink.com)

 [maestro.idatalink.com/support](http://maestro.idatalink.com/support)  
[www.12voltdata.com/forum](http://www.12voltdata.com/forum)

## TABLE OF CONTENTS

Wiring Diagram	<b>3</b>
Vehicle Wire Reference Chart	<b>4</b>

# WIRING DIAGRAM

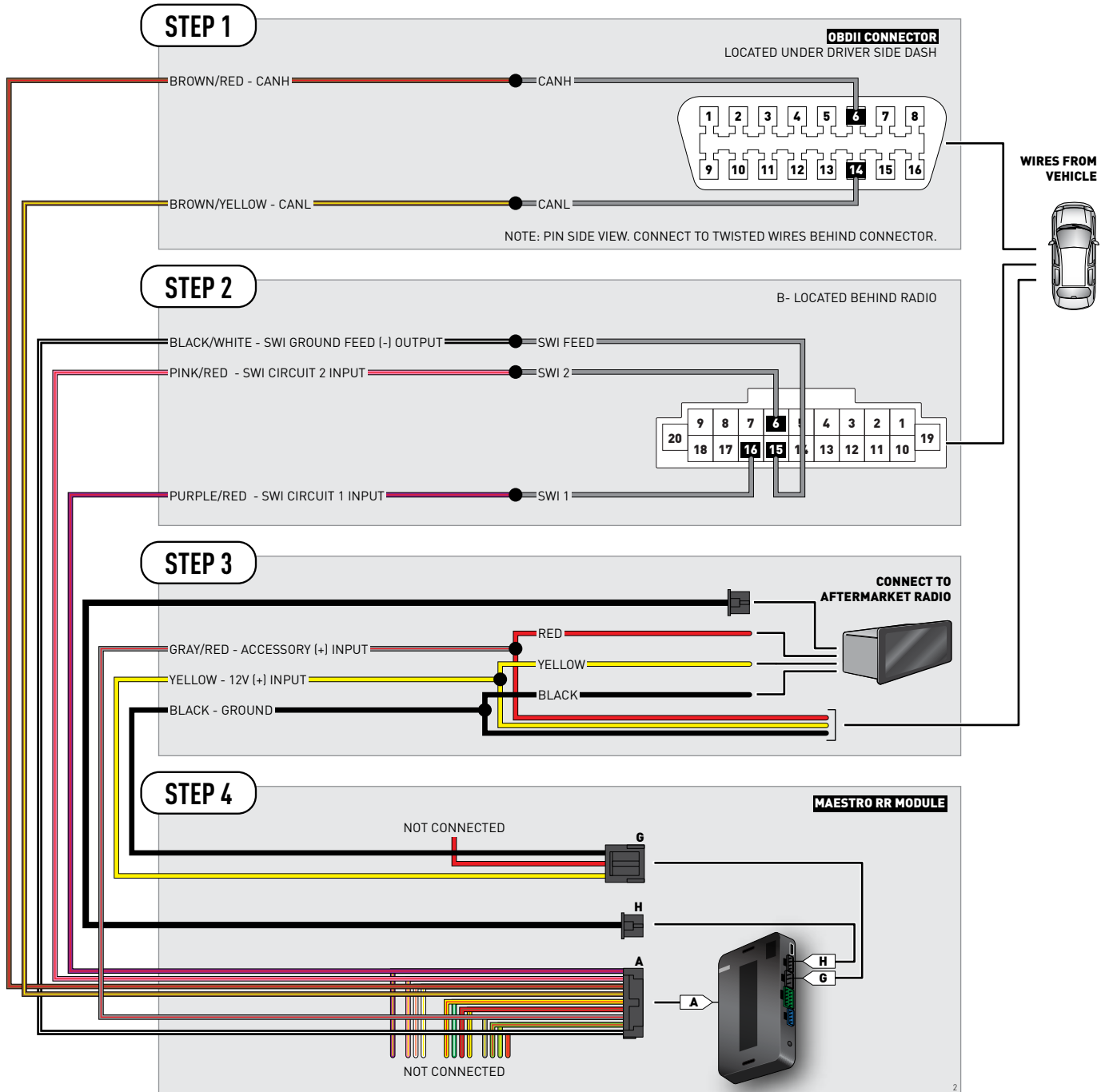



# VEHICLE WIRE REFERENCE CHART

Wire Description	Connector Name	Connector Color	Connector Type	Position	Wire Color	Polarity	Wire Location
CanH	A	~	16 pin	06	Blue	[DATA]	OBDII connector, under driver side dash
CanL	A	~	16 pin	14	Pink	[DATA]	OBDII connector, under driver side dash
SWI 1	B	~	20 pin	16	Yellow	[DATA]	Behind radio
SWI 2	B		20 pin	06	Brown	[DATA]	Behind radio
SWI Feed	B	~	20 pin	15	Bare	(-)	Behind radio



# INSTALL GUIDE

# NISSAN PATHFINDER

## 2009-2012

RETAINS STEERING WHEEL CONTROLS AND ADDS GAUGES



#### PRODUCTS REQUIRED

iDatalink Maestro RR Radio Replacement Interface  
iDatalink Compatible Radio

#### PROGRAMMED FIRMWARE

ADS-RR(SI)-NIS01-DS

#### OPTIONAL ACCESSORIES



Click here for:

[Radar Integration Installation Guide](#)

[Radar Integration Owner's Guide for Kenwood and JVC Radios](#)

# WELCOME

Congratulations on the purchase of your iDatalink Maestro RR Radio replacement solution. You are now a few simple steps away from enjoying your new car radio with enhanced features.

Before starting your installation, please ensure that your iDatalink Maestro module is programmed with the correct firmware for your vehicle and that you carefully review the install guide.

**Please note that Maestro RR will only retain functionalities that were originally available in the vehicle.**

# NEED HELP?

 **1 866 427-2999**

 [support@idatalink.com](mailto:support@idatalink.com)

 [maestro.idatalink.com/support](http://maestro.idatalink.com/support)  
[www.12voltdata.com/forum](http://www.12voltdata.com/forum)

## TABLE OF CONTENTS

Wiring Diagram	<b>3</b>
Vehicle Wire Reference Chart	<b>4</b>

# WIRING DIAGRAM



# VEHICLE WIRE REFERENCE CHART

Wire Description	Connector Name	Connector Color	Connector Type	Position	Wire Color	Polarity	Wire Location
CanH	A	~	16 pin	06	Blue	(DATA)	OBDII connector, under driver side dash
CanL	A	~	16 pin	14	Pink	(DATA)	OBDII connector, under driver side dash
SWI 1	B	~	20 pin	16	Green	(DATA)	Behind radio
SWI 2	B		20 pin	06	Yellow	(DATA)	Behind radio
SWI Feed	B	~	20 pin	15	Blue	(-)	Behind radio



# INSTALL GUIDE

# NISSAN QUEST

# WITH 4.3IN SCREEN

# 2011-2014

RETAINS STEERING WHEEL CONTROLS AND ADDS GAUGES



#### PRODUCTS REQUIRED

iDatalink Maestro RR Radio Replacement Interface  
iDatalink Compatible Radio

#### PROGRAMMED FIRMWARE

ADS-RR(SI)-NIS01-DS

#### OPTIONAL ACCESSORIES



Click here for:

[Radar Integration Installation Guide](#)

[Radar Integration Owner's Guide for Kenwood and JVC Radios](#)

# WELCOME

Congratulations on the purchase of your iDatalink Maestro RR Radio replacement solution. You are now a few simple steps away from enjoying your new car radio with enhanced features.

Before starting your installation, please ensure that your iDatalink Maestro module is programmed with the correct firmware for your vehicle and that you carefully review the install guide.

**Please note that Maestro RR will only retain functionalities that were originally available in the vehicle.**

# NEED HELP?

 **1 866 427-2999**

 [support@idatalink.com](mailto:support@idatalink.com)

 [maestro.idatalink.com/support](http://maestro.idatalink.com/support)  
[www.12voltdata.com/forum](http://www.12voltdata.com/forum)

## TABLE OF CONTENTS

Wiring Diagram	3
Vehicle Wire Reference Chart	4

# WIRING DIAGRAM

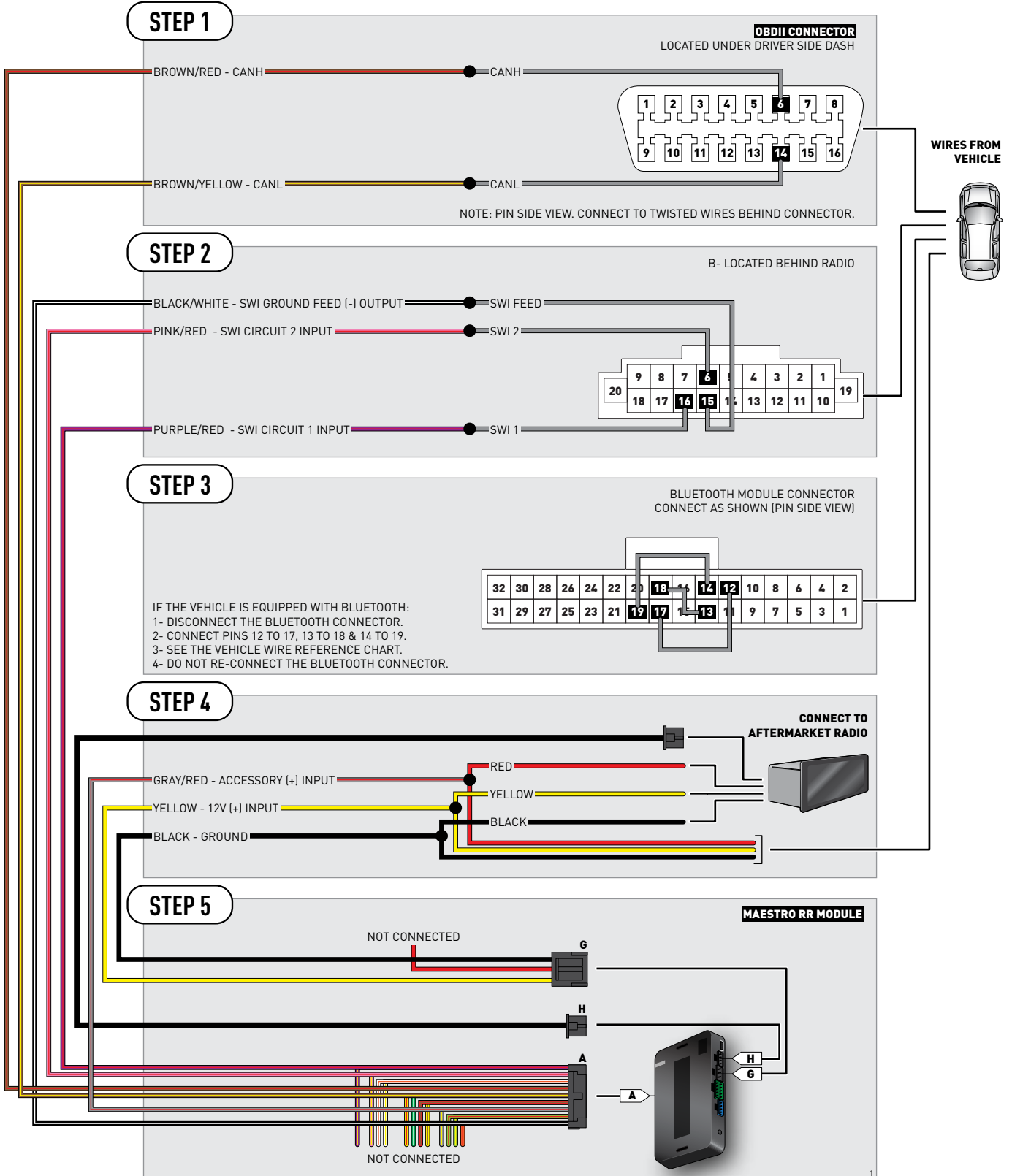



# VEHICLE WIRE REFERENCE CHART

Wire Description	Connector Name	Connector Color	Connector Type	Position	Wire Color	Polarity	Wire Location
CanH	A	~	16 pin	06	Blue	(DATA)	OBDII connector, under driver side dash
CanL	A	~	16 pin	14	Pink	(DATA)	OBDII connector, under driver side dash
SWI 1	B	~	20 pin	16	LtBlue	(DATA)	Behind radio
SWI 2	B		20 pin	06	Red	(DATA)	Behind radio
SWI Feed	B	~	20 pin	15	Yellow	(-)	Behind radio
BT-12	~	~	32 pin	12	Green	~	Behind center dash, under radio
BT-13	~	~	32 pin	13	Purple	~	Behind center dash, under radio
BT-14	~	~	32 pin	14	Gray	~	Behind center dash, under radio
BT-17	~	~	32 pin	17	Red	~	Behind center dash, under radio
BT-18	~	~	32 pin	18	LtBlue	~	Behind center dash, under radio
BT-19	~	~	32 pin	19	Yellow	~	Behind center dash, under radio



# INSTALL GUIDE

# NISSAN QUEST

# WITH 4.3IN SCREEN

# 2015-2016

RETAINS STEERING WHEEL CONTROLS AND ADDS GAUGES



#### PRODUCTS REQUIRED

iDatalink Maestro RR Radio Replacement Interface  
iDatalink Compatible Radio

#### PROGRAMMED FIRMWARE

ADS-RR(SI)-NIS01-DS

#### OPTIONAL ACCESSORIES



Click here for:

[Radar Integration Installation Guide](#)

[Radar Integration Owner's Guide for Kenwood and JVC Radios](#)

# WELCOME

Congratulations on the purchase of your iDatalink Maestro RR Radio replacement solution. You are now a few simple steps away from enjoying your new car radio with enhanced features.

Before starting your installation, please ensure that your iDatalink Maestro module is programmed with the correct firmware for your vehicle and that you carefully review the install guide.

**Please note that Maestro RR will only retain functionalities that were originally available in the vehicle.**

# NEED HELP?

 **1 866 427-2999**

 [support@idatalink.com](mailto:support@idatalink.com)

 [maestro.idatalink.com/support](http://maestro.idatalink.com/support)  
[www.12voltdata.com/forum](http://www.12voltdata.com/forum)

## TABLE OF CONTENTS

Wiring Diagram	<b>3</b>
Vehicle Wire Reference Chart	<b>4</b>

# WIRING DIAGRAM



# VEHICLE WIRE REFERENCE CHART

Wire Description	Connector Name	Connector Color	Connector Type	Position	Wire Color	Polarity	Wire Location
CanH	A	~	16 pin	06	Blue	[DATA]	OBDII connector, under driver side dash
CanL	A	~	16 pin	14	Pink	[DATA]	OBDII connector, under driver side dash
SWI 1	B	~	20 pin	16	Pink or Purple	[DATA]	Behind radio
SWI 2	B		20 pin	06	Green	[DATA]	Behind radio
SWI Feed	B	~	20 pin	15	Gray	(-)	Behind radio



# INSTALL GUIDE

# NISSAN QUEST

# WITHOUT 4.3IN SCREEN

# 2011-2014

RETAINS STEERING WHEEL CONTROLS AND ADDS GAUGES



#### PRODUCTS REQUIRED

iDatalink Maestro RR Radio Replacement Interface  
iDatalink Compatible Radio

#### PROGRAMMED FIRMWARE

ADS-RR(SI)-NIS01-DS

#### OPTIONAL ACCESSORIES



Click here for:

[Radar Integration Installation Guide](#)

[Radar Integration Owner's Guide for Kenwood and JVC Radios](#)

# WELCOME

Congratulations on the purchase of your iDatalink Maestro RR Radio replacement solution. You are now a few simple steps away from enjoying your new car radio with enhanced features.

Before starting your installation, please ensure that your iDatalink Maestro module is programmed with the correct firmware for your vehicle and that you carefully review the install guide.

**Please note that Maestro RR will only retain functionalities that were originally available in the vehicle.**

# NEED HELP?

 **1 866 427-2999**

 [support@idatalink.com](mailto:support@idatalink.com)

 [maestro.idatalink.com/support](http://maestro.idatalink.com/support)  
[www.12voltdata.com/forum](http://www.12voltdata.com/forum)

## TABLE OF CONTENTS

Wiring Diagram	<b>3</b>
Vehicle Wire Reference Chart	<b>4</b>

# WIRING DIAGRAM

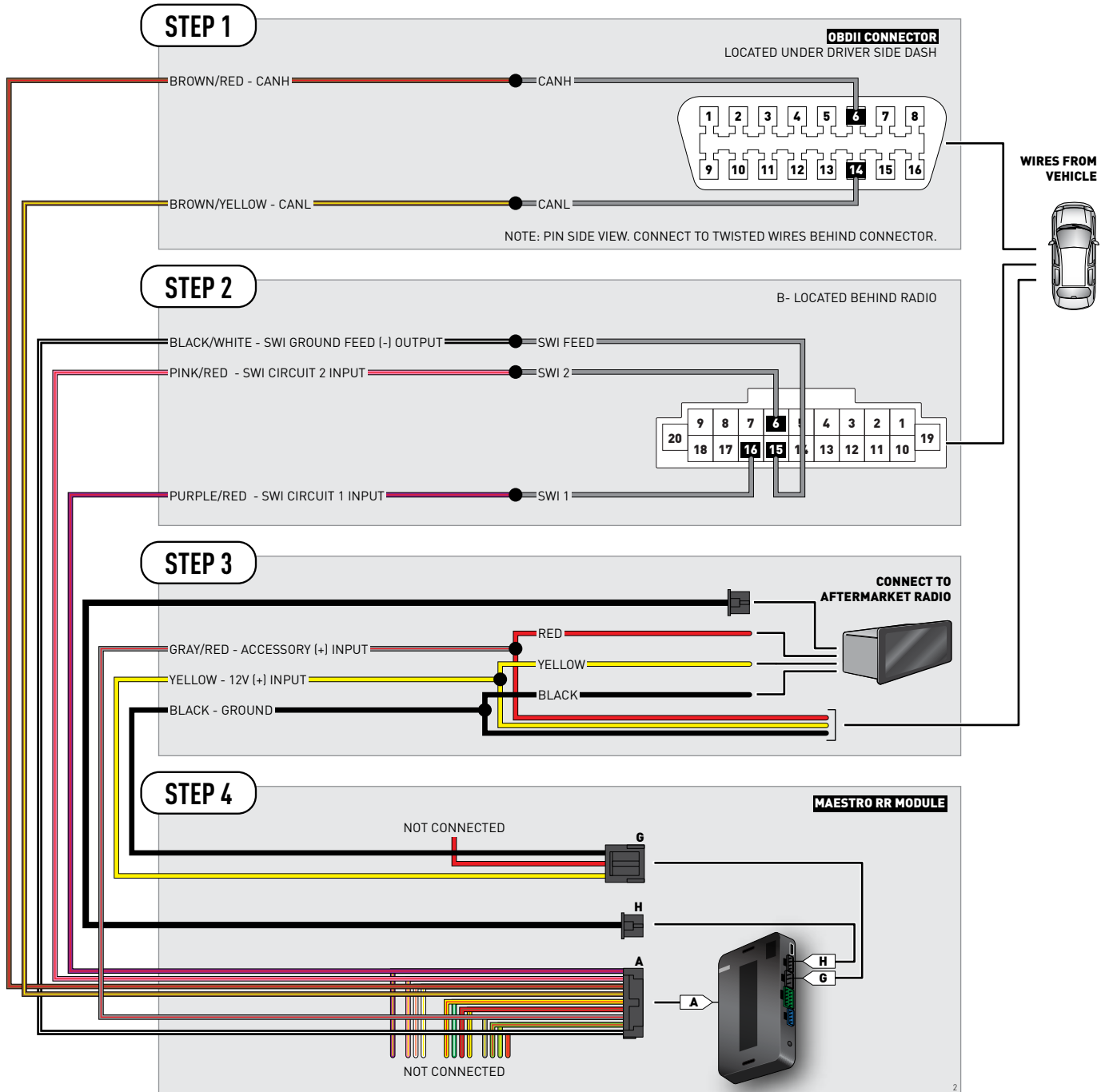



# VEHICLE WIRE REFERENCE CHART

Wire Description	Connector Name	Connector Color	Connector Type	Position	Wire Color	Polarity	Wire Location
CanH	A	~	16 pin	06	Blue	[DATA]	OBDII connector, under driver side dash
CanL	A	~	16 pin	14	Pink	[DATA]	OBDII connector, under driver side dash
SWI 1	B	~	20 pin	16	Pink	[DATA]	Behind radio
SWI 2	B		20 pin	06	Blue	[DATA]	Behind radio
SWI Feed	B	~	20 pin	15	Gray	(-)	Behind radio



# INSTALL GUIDE

# NISSAN QUEST

# WITHOUT 4.3IN SCREEN

# 2015-2016

RETAINS STEERING WHEEL CONTROLS AND ADDS GAUGES



#### PRODUCTS REQUIRED

iDatalink Maestro RR Radio Replacement Interface  
iDatalink Compatible Radio

#### PROGRAMMED FIRMWARE

ADS-RR(SI)-NIS01-DS

#### OPTIONAL ACCESSORIES



Click here for:

[Radar Integration Installation Guide](#)

[Radar Integration Owner's Guide for Kenwood and JVC Radios](#)

# WELCOME

Congratulations on the purchase of your iDatalink Maestro RR Radio replacement solution. You are now a few simple steps away from enjoying your new car radio with enhanced features.

Before starting your installation, please ensure that your iDatalink Maestro module is programmed with the correct firmware for your vehicle and that you carefully review the install guide.

**Please note that Maestro RR will only retain functionalities that were originally available in the vehicle.**

# NEED HELP?

 **1 866 427-2999**

 [support@idatalink.com](mailto:support@idatalink.com)

 [maestro.idatalink.com/support](http://maestro.idatalink.com/support)  
[www.12voltdata.com/forum](http://www.12voltdata.com/forum)

## TABLE OF CONTENTS

Wiring Diagram	<b>3</b>
Vehicle Wire Reference Chart	<b>4</b>

# WIRING DIAGRAM

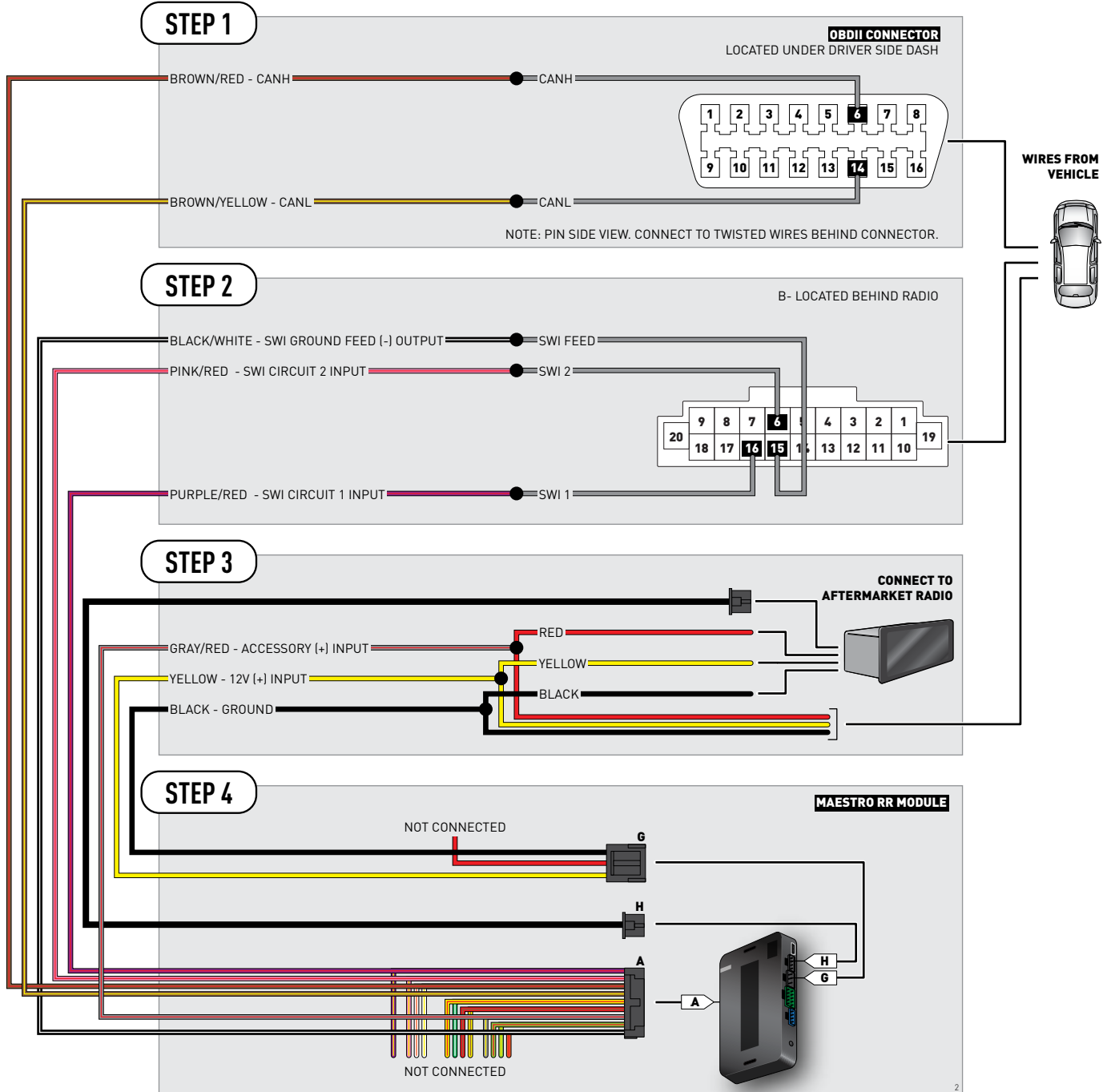

# VEHICLE WIRE REFERENCE CHART

Wire Description	Connector Name	Connector Color	Connector Type	Position	Wire Color	Polarity	Wire Location
CanH	A	~	16 pin	06	Blue	[DATA]	OBDII connector, under driver side dash
CanL	A	~	16 pin	14	Pink	[DATA]	OBDII connector, under driver side dash
SWI 1	B	~	20 pin	16	Pink	[DATA]	Behind radio
SWI 2	B		20 pin	06	Tan or Orange	[DATA]	Behind radio
SWI Feed	B	~	20 pin	15	White	(-)	Behind radio

iDatalink  
**maestro RR**

# INSTALL GUIDE

# NISSAN ROGUE

# BASE

# 2008-2013

RETAINS STEERING WHEEL CONTROLS AND ADDS GAUGES



#### PRODUCTS REQUIRED

iDatalink Maestro RR Radio Replacement Interface  
iDatalink Compatible Radio

#### PROGRAMMED FIRMWARE

ADS-RR(SI)-NIS01-DS

#### OPTIONAL ACCESSORIES

**K4O**<sup>™</sup>  
ELECTRONICS

Click here for:

[Radar Integration Installation Guide](#)

[Radar Integration Owner's Guide for Kenwood and JVC Radios](#)

# WELCOME

Congratulations on the purchase of your iDatalink Maestro RR Radio replacement solution. You are now a few simple steps away from enjoying your new car radio with enhanced features.

Before starting your installation, please ensure that your iDatalink Maestro module is programmed with the correct firmware for your vehicle and that you carefully review the install guide.

**Please note that Maestro RR will only retain functionalities that were originally available in the vehicle.**

# NEED HELP?

 **1 866 427-2999**

 [support@idatalink.com](mailto:support@idatalink.com)

 [maestro.idatalink.com/support](http://maestro.idatalink.com/support)  
[www.12voltdata.com/forum](http://www.12voltdata.com/forum)

## TABLE OF CONTENTS

Wiring Diagram	<b>3</b>
Vehicle Wire Reference Chart	<b>4</b>

# WIRING DIAGRAM

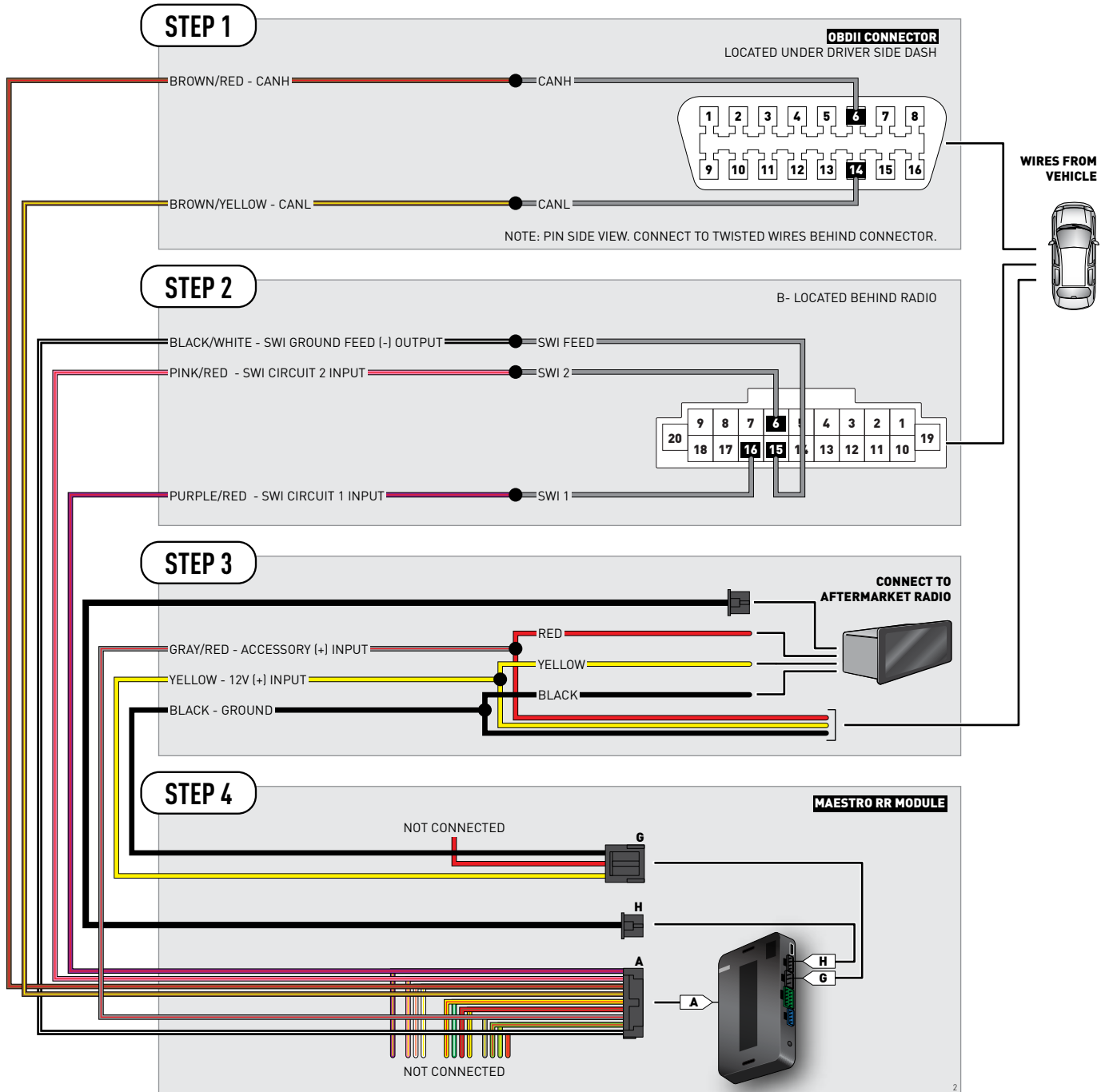



# VEHICLE WIRE REFERENCE CHART

Wire Description	Connector Name	Connector Color	Connector Type	Position	Wire Color	Polarity	Wire Location
CanH	A	~	16 pin	06	Blue	[DATA]	OBDII connector, under driver side dash
CanL	A	~	16 pin	14	Pink	[DATA]	OBDII connector, under driver side dash
SWI 1	B	~	20 pin	16	Orange	[DATA]	Behind radio
SWI 2	B		20 pin	06	Brown or White	[DATA]	Behind radio
SWI Feed	B	~	20 pin	15	Gray	(-)	Behind radio

iDATALINK  
maestro *RR*

# INSTALL GUIDE

# NISSAN ROGUE

# BLUETOOTH

# 2009-2013

RETAINS STEERING WHEEL CONTROLS AND ADDS GAUGES



#### PRODUCTS REQUIRED

iDatalink Maestro RR Radio Replacement Interface  
iDatalink Compatible Radio

#### PROGRAMMED FIRMWARE

ADS-RR(SI)-NIS01-DS

#### OPTIONAL ACCESSORIES

**K4O**<sup>TM</sup>  
ELECTRONICS

Click here for:

[Radar Integration Installation Guide](#)

[Radar Integration Owner's Guide for Kenwood and JVC Radios](#)

# WELCOME

Congratulations on the purchase of your iDatalink Maestro RR Radio replacement solution. You are now a few simple steps away from enjoying your new car radio with enhanced features.

Before starting your installation, please ensure that your iDatalink Maestro module is programmed with the correct firmware for your vehicle and that you carefully review the install guide.

**Please note that Maestro RR will only retain functionalities that were originally available in the vehicle.**

# NEED HELP?

 **1 866 427-2999**

 [support@idatalink.com](mailto:support@idatalink.com)

 [maestro.idatalink.com/support](http://maestro.idatalink.com/support)  
[www.12voltdata.com/forum](http://www.12voltdata.com/forum)

## TABLE OF CONTENTS

Wiring Diagram	<b>3</b>
Vehicle Wire Reference Chart	<b>4</b>

# WIRING DIAGRAM

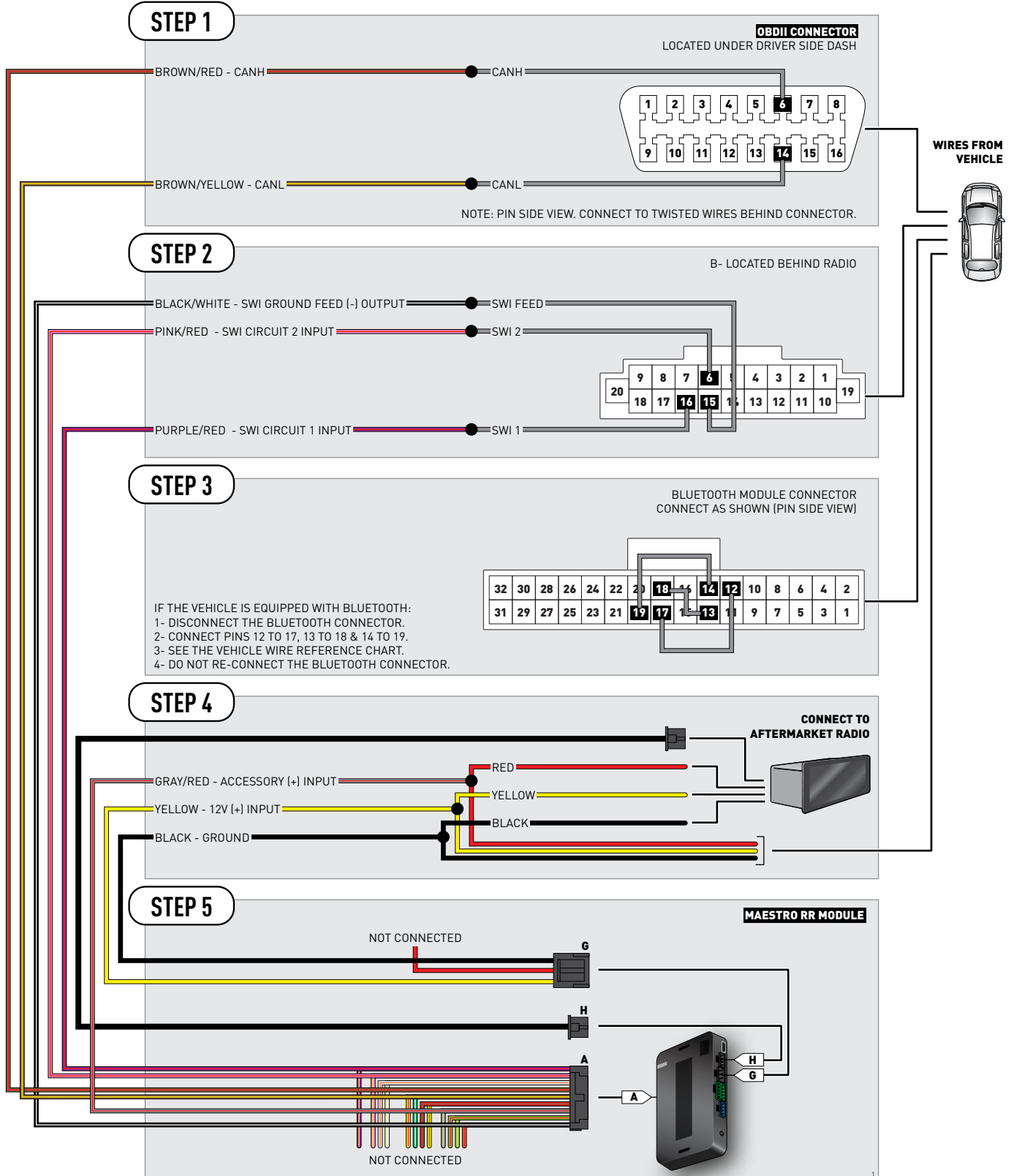

# VEHICLE WIRE REFERENCE CHART

Wire Description	Connector Name	Connector Color	Connector Type	Position	Wire Color	Polarity	Wire Location
CanH	A	~	16 pin	06	Blue	(DATA)	OBDII connector, under driver side dash
CanL	A	~	16 pin	14	Pink	(DATA)	OBDII connector, under driver side dash
SWI 1	B	~	20 pin	16	Orange	(DATA)	Behind radio
SWI 2	B		20 pin	06	Brown or White	(DATA)	Behind radio
SWI Feed	B	~	20 pin	15	Gray	(-)	Behind radio
BT-12	~	~	32 pin	12	White	~	Trunk, right side
BT-13	~	~	32 pin	13	Yellow	~	Trunk, right side
BT-14	~	~	32 pin	14	Gray	~	Trunk, right side
BT-17	~	~	32 pin	17	White	~	Trunk, right side
BT-18	~	~	32 pin	18	Blue	~	Trunk, right side
BT-19	~	~	32 pin	19	Gray	~	Trunk, right side



# INSTALL GUIDE

# NISSAN ROGUE

# NAV AND BLUETOOTH

# 2011-2013

RETAINS STEERING WHEEL CONTROLS AND ADDS GAUGES



#### PRODUCTS REQUIRED

iDatalink Maestro RR Radio Replacement Interface  
iDatalink Compatible Radio

#### PROGRAMMED FIRMWARE

ADS-RR(SI)-NIS01-DS

#### OPTIONAL ACCESSORIES



Click here for:

[Radar Integration Installation Guide](#)

[Radar Integration Owner's Guide for Kenwood and JVC Radios](#)

# WELCOME

Congratulations on the purchase of your iDatalink Maestro RR Radio replacement solution. You are now a few simple steps away from enjoying your new car radio with enhanced features.

Before starting your installation, please ensure that your iDatalink Maestro module is programmed with the correct firmware for your vehicle and that you carefully review the install guide.

**Please note that Maestro RR will only retain functionalities that were originally available in the vehicle.**

# NEED HELP?

 **1 866 427-2999**

 [support@idatalink.com](mailto:support@idatalink.com)

 [maestro.idatalink.com/support](http://maestro.idatalink.com/support)  
[www.12voltdata.com/forum](http://www.12voltdata.com/forum)

## TABLE OF CONTENTS

Wiring Diagram	<b>3</b>
Vehicle Wire Reference Chart	<b>4</b>

# WIRING DIAGRAM

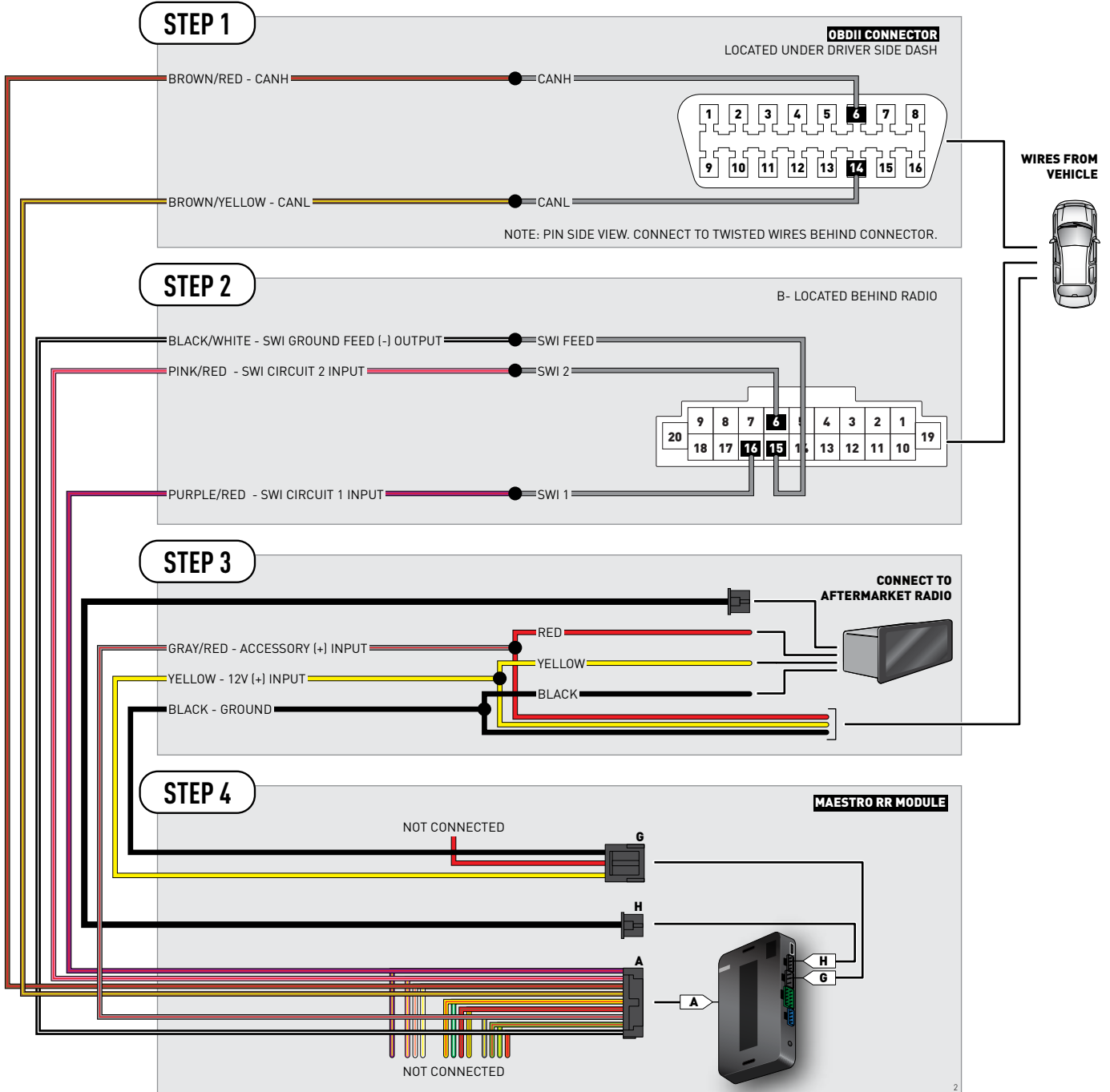



# VEHICLE WIRE REFERENCE CHART

Wire Description	Connector Name	Connector Color	Connector Type	Position	Wire Color	Polarity	Wire Location
CanH	A	~	16 pin	06	Blue	[DATA]	OBDII connector, under driver side dash
CanL	A	~	16 pin	14	Pink	[DATA]	OBDII connector, under driver side dash
SWI 1	B	~	20 pin	16	Orange	[DATA]	Behind radio
SWI 2	B		20 pin	06	Brown	[DATA]	Behind radio
SWI Feed	B	~	20 pin	15	Gray	(-)	Behind radio



# INSTALL GUIDE

# NISSAN ROGUE SELECT

# BASE

# 2014-2015

RETAINS STEERING WHEEL CONTROLS AND ADDS GAUGES



#### PRODUCTS REQUIRED

iDatalink Maestro RR Radio Replacement Interface  
iDatalink Compatible Radio

#### PROGRAMMED FIRMWARE

ADS-RR(SI)-NIS01-DS

#### OPTIONAL ACCESSORIES



Click here for:

[Radar Integration Installation Guide](#)

[Radar Integration Owner's Guide for Kenwood and JVC Radios](#)

# WELCOME

Congratulations on the purchase of your iDatalink Maestro RR Radio replacement solution. You are now a few simple steps away from enjoying your new car radio with enhanced features.

Before starting your installation, please ensure that your iDatalink Maestro module is programmed with the correct firmware for your vehicle and that you carefully review the install guide.

**Please note that Maestro RR will only retain functionalities that were originally available in the vehicle.**

# NEED HELP?

 **1 866 427-2999**

 **[support@idatalink.com](mailto:support@idatalink.com)**

 **[maestro.idatalink.com/support](http://maestro.idatalink.com/support)  
[www.12voltdata.com/forum](http://www.12voltdata.com/forum)**

## TABLE OF CONTENTS

Wiring Diagram	<b>3</b>
Vehicle Wire Reference Chart	<b>4</b>

# WIRING DIAGRAM

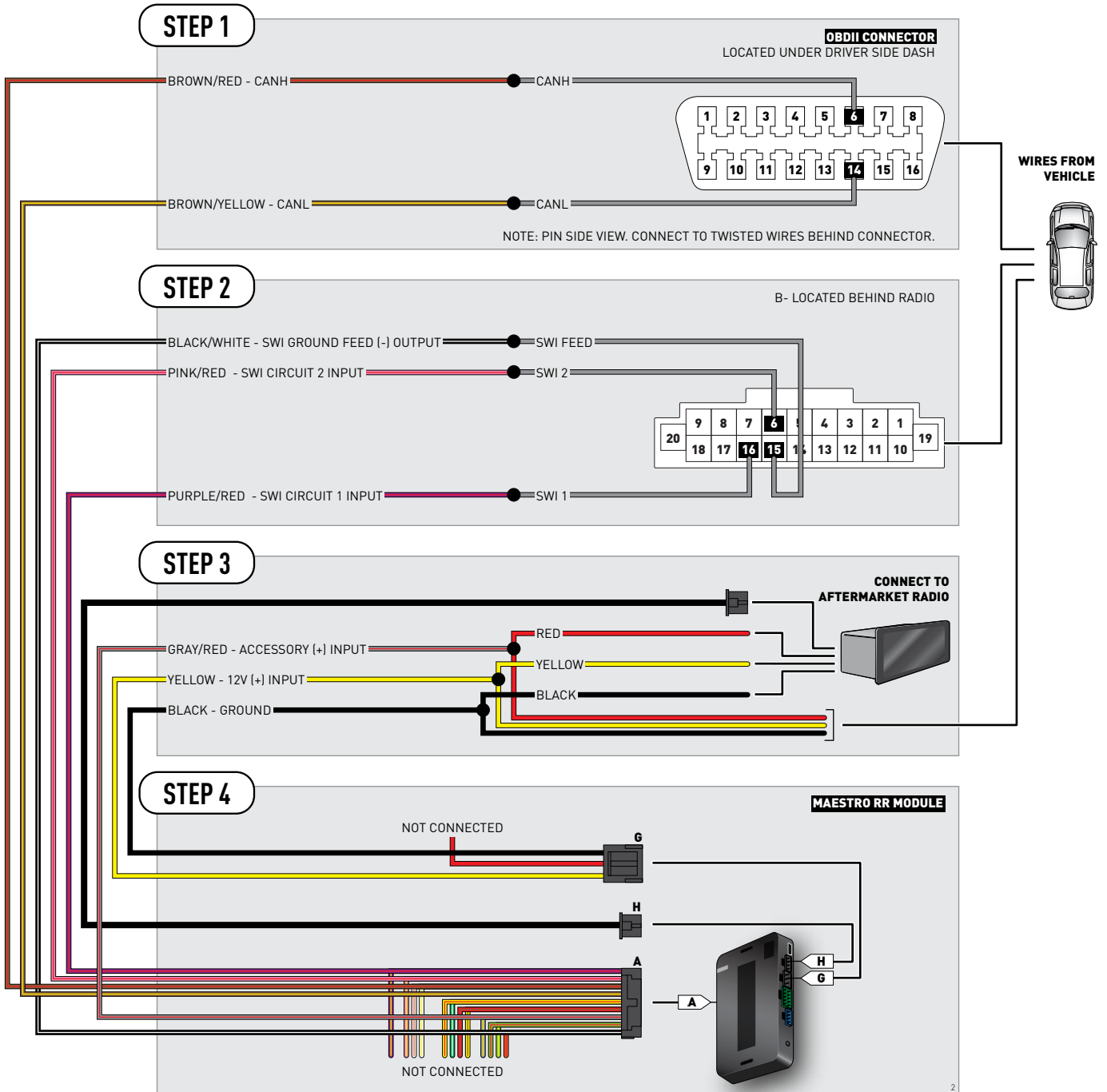

# VEHICLE WIRE REFERENCE CHART

Wire Description	Connector Name	Connector Color	Connector Type	Position	Wire Color	Polarity	Wire Location
CanH	A	~	16 pin	06	Blue	[DATA]	OBDII connector, under driver side dash
CanL	A	~	16 pin	14	Pink	[DATA]	OBDII connector, under driver side dash
SWI 1	B	~	20 pin	16	Orange	[DATA]	Behind radio
SWI 2	B		20 pin	06	Brown or White	[DATA]	Behind radio
SWI Feed	B	~	20 pin	15	Gray	(-)	Behind radio



# INSTALL GUIDE

# NISSAN ROGUE SELECT

# BLUETOOTH

# 2014-2015

RETAINS STEERING WHEEL CONTROLS AND ADDS GAUGES



#### PRODUCTS REQUIRED

iDatalink Maestro RR Radio Replacement Interface  
iDatalink Compatible Radio

#### PROGRAMMED FIRMWARE

ADS-RR(SI)-NIS01-DS

#### OPTIONAL ACCESSORIES



Click here for:

[Radar Integration Installation Guide](#)

[Radar Integration Owner's Guide for Kenwood and JVC Radios](#)

# WELCOME

Congratulations on the purchase of your iDatalink Maestro RR Radio replacement solution. You are now a few simple steps away from enjoying your new car radio with enhanced features.

Before starting your installation, please ensure that your iDatalink Maestro module is programmed with the correct firmware for your vehicle and that you carefully review the install guide.

**Please note that Maestro RR will only retain functionalities that were originally available in the vehicle.**

# NEED HELP?

 **1 866 427-2999**

 [support@idatalink.com](mailto:support@idatalink.com)

 [maestro.idatalink.com/support](http://maestro.idatalink.com/support)  
[www.12voltdata.com/forum](http://www.12voltdata.com/forum)

## TABLE OF CONTENTS

Wiring Diagram	<b>3</b>
Vehicle Wire Reference Chart	<b>4</b>

# WIRING DIAGRAM

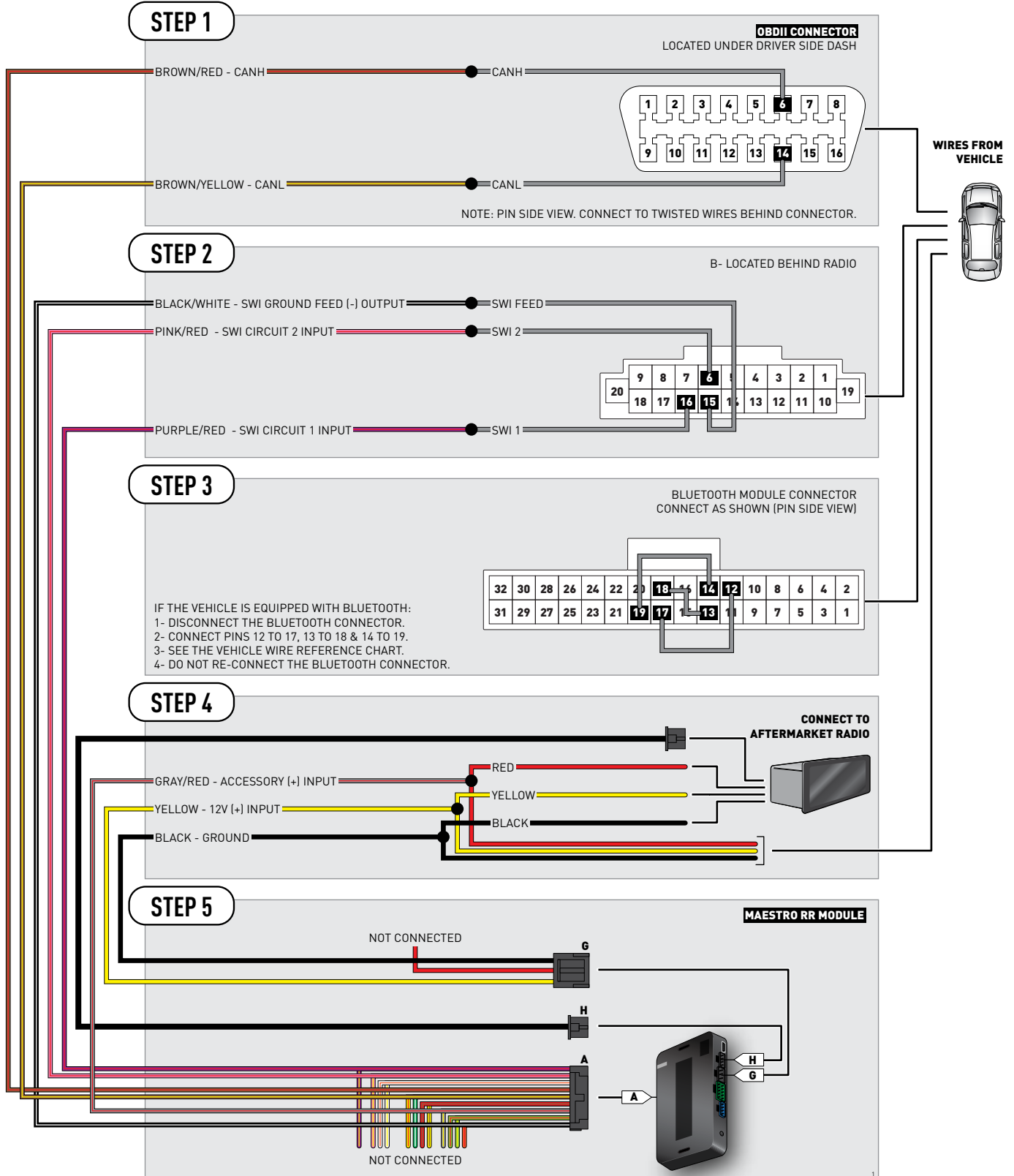



# VEHICLE WIRE REFERENCE CHART

Wire Description	Connector Name	Connector Color	Connector Type	Position	Wire Color	Polarity	Wire Location
CanH	A	~	16 pin	06	Blue	(DATA)	OBDII connector, under driver side dash
CanL	A	~	16 pin	14	Pink	(DATA)	OBDII connector, under driver side dash
SWI 1	B	~	20 pin	16	Orange	(DATA)	Behind radio
SWI 2	B		20 pin	06	Brown or White	(DATA)	Behind radio
SWI Feed	B	~	20 pin	15	Gray	(-)	Behind radio
BT-12	~	~	32 pin	12	White	~	Trunk, right side
BT-13	~	~	32 pin	13	Yellow	~	Trunk, right side
BT-14	~	~	32 pin	14	Gray	~	Trunk, right side
BT-17	~	~	32 pin	17	White	~	Trunk, right side
BT-18	~	~	32 pin	18	Blue	~	Trunk, right side
BT-19	~	~	32 pin	19	Gray	~	Trunk, right side



# INSTALL GUIDE

# NISSAN ROGUE SELECT

# NAV AND BLUETOOTH

# 2014-2015

RETAINS STEERING WHEEL CONTROLS AND ADDS GAUGES



#### PRODUCTS REQUIRED

iDatalink Maestro RR Radio Replacement Interface  
iDatalink Compatible Radio

#### PROGRAMMED FIRMWARE

ADS-RR(SI)-NIS01-DS

#### OPTIONAL ACCESSORIES



Click here for:

[Radar Integration Installation Guide](#)

[Radar Integration Owner's Guide for Kenwood and JVC Radios](#)

# WELCOME

Congratulations on the purchase of your iDatalink Maestro RR Radio replacement solution. You are now a few simple steps away from enjoying your new car radio with enhanced features.

Before starting your installation, please ensure that your iDatalink Maestro module is programmed with the correct firmware for your vehicle and that you carefully review the install guide.

**Please note that Maestro RR will only retain functionalities that were originally available in the vehicle.**

# NEED HELP?

 **1 866 427-2999**

 [support@idatalink.com](mailto:support@idatalink.com)

 [maestro.idatalink.com/support](http://maestro.idatalink.com/support)  
[www.12voltdata.com/forum](http://www.12voltdata.com/forum)

## TABLE OF CONTENTS

Wiring Diagram	<b>3</b>
Vehicle Wire Reference Chart	<b>4</b>

# WIRING DIAGRAM



# VEHICLE WIRE REFERENCE CHART

Wire Description	Connector Name	Connector Color	Connector Type	Position	Wire Color	Polarity	Wire Location
CanH	A	~	16 pin	06	Blue	[DATA]	OBDII connector, under driver side dash
CanL	A	~	16 pin	14	Pink	[DATA]	OBDII connector, under driver side dash
SWI 1	B	~	20 pin	16	Orange	[DATA]	Behind radio
SWI 2	B		20 pin	06	Brown	[DATA]	Behind radio
SWI Feed	B	~	20 pin	15	Gray	(-)	Behind radio



# INSTALL GUIDE

# NISSAN ROGUE SELECT

# WITH BOSE

# 2014-2015

RETAINS STEERING WHEEL CONTROLS AND ADDS GAUGES



#### PRODUCTS REQUIRED

iDatalink Maestro RR Radio Replacement Interface  
iDatalink Compatible Radio

#### PROGRAMMED FIRMWARE

ADS-RR(SI)-NIS01-DS

#### OPTIONAL ACCESSORIES



Click here for:

[Radar Integration Installation Guide](#)

[Radar Integration Owner's Guide for Kenwood and JVC Radios](#)

# WELCOME

Congratulations on the purchase of your iDatalink Maestro RR Radio replacement solution. You are now a few simple steps away from enjoying your new car radio with enhanced features.

Before starting your installation, please ensure that your iDatalink Maestro module is programmed with the correct firmware for your vehicle and that you carefully review the install guide.

**Please note that Maestro RR will only retain functionalities that were originally available in the vehicle.**

# NEED HELP?

 **1 866 427-2999**

 [support@idatalink.com](mailto:support@idatalink.com)

 [maestro.idatalink.com/support](http://maestro.idatalink.com/support)  
[www.12voltdata.com/forum](http://www.12voltdata.com/forum)

## TABLE OF CONTENTS

Wiring Diagram	<b>3</b>
Vehicle Wire Reference Chart	<b>4</b>

# WIRING DIAGRAM

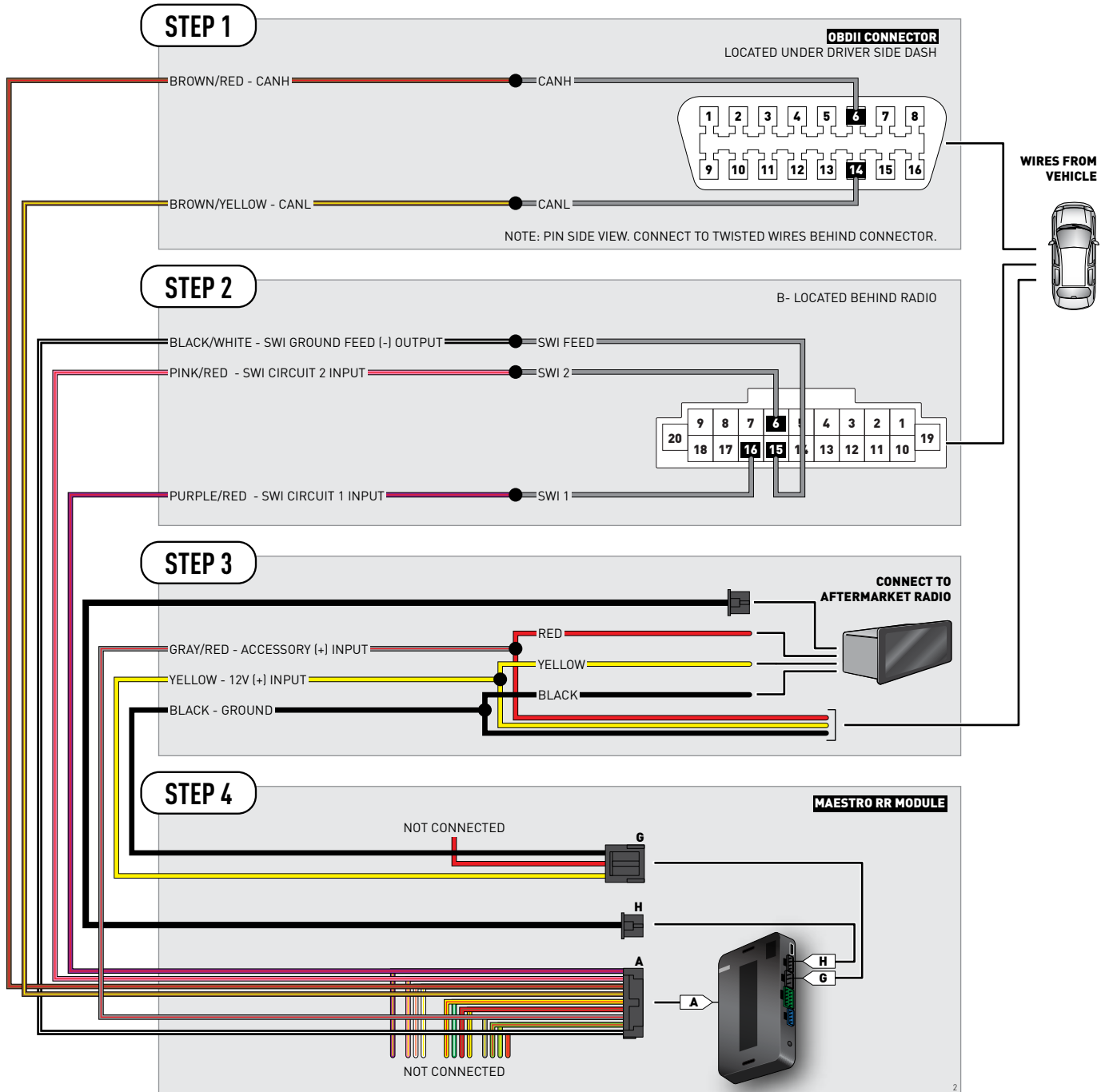



# VEHICLE WIRE REFERENCE CHART

Wire Description	Connector Name	Connector Color	Connector Type	Position	Wire Color	Polarity	Wire Location
CanH	A	~	16 pin	06	Blue	[DATA]	OBDII connector, under driver side dash
CanL	A	~	16 pin	14	Pink	[DATA]	OBDII connector, under driver side dash
SWI 1	B	~	20 pin	16	Tan	[DATA]	Behind radio
SWI 2	B		20 pin	06	Brown	[DATA]	Behind radio
SWI Feed	B	~	20 pin	15	Gray	(-)	Behind radio



# INSTALL GUIDE NISSAN ROGUE WITH BOSE 2012-2013

RETAINS STEERING WHEEL CONTROLS AND ADDS GAUGES



#### PRODUCTS REQUIRED

iDatalink Maestro RR Radio Replacement Interface  
iDatalink Compatible Radio

#### PROGRAMMED FIRMWARE

ADS-RR(SI)-NIS01-DS

#### OPTIONAL ACCESSORIES



Click here for:

[Radar Integration Installation Guide](#)

[Radar Integration Owner's Guide for Kenwood and JVC Radios](#)

# WELCOME

Congratulations on the purchase of your iDatalink Maestro RR Radio replacement solution. You are now a few simple steps away from enjoying your new car radio with enhanced features.

Before starting your installation, please ensure that your iDatalink Maestro module is programmed with the correct firmware for your vehicle and that you carefully review the install guide.

**Please note that Maestro RR will only retain functionalities that were originally available in the vehicle.**

# NEED HELP?

 **1 866 427-2999**

 **support@idatalink.com**

 **maestro.idatalink.com/support**  
**www.12voltdata.com/forum**

## TABLE OF CONTENTS

Wiring Diagram	<b>3</b>
Vehicle Wire Reference Chart	<b>4</b>

# WIRING DIAGRAM



# VEHICLE WIRE REFERENCE CHART

Wire Description	Connector Name	Connector Color	Connector Type	Position	Wire Color	Polarity	Wire Location
CanH	A	~	16 pin	06	Blue	[DATA]	OBDII connector, under driver side dash
CanL	A	~	16 pin	14	Pink	[DATA]	OBDII connector, under driver side dash
SWI 1	B	~	20 pin	16	Tan	[DATA]	Behind radio
SWI 2	B		20 pin	06	Brown	[DATA]	Behind radio
SWI Feed	B	~	20 pin	15	Gray	(-)	Behind radio



# INSTALL GUIDE

# NISSAN SENTRA

# BASE

# 2009-2012

RETAINS STEERING WHEEL CONTROLS AND ADDS GAUGES



#### PRODUCTS REQUIRED

iDatalink Maestro RR Radio Replacement Interface  
iDatalink Compatible Radio

#### PROGRAMMED FIRMWARE

ADS-RR(SI)-NIS01-DS

#### OPTIONAL ACCESSORIES



Click here for:

[Radar Integration Installation Guide](#)

[Radar Integration Owner's Guide for Kenwood and JVC Radios](#)

# WELCOME

Congratulations on the purchase of your iDatalink Maestro RR Radio replacement solution. You are now a few simple steps away from enjoying your new car radio with enhanced features.

Before starting your installation, please ensure that your iDatalink Maestro module is programmed with the correct firmware for your vehicle and that you carefully review the install guide.

**Please note that Maestro RR will only retain functionalities that were originally available in the vehicle.**

# NEED HELP?

 **1 866 427-2999**

 [support@idatalink.com](mailto:support@idatalink.com)

 [maestro.idatalink.com/support](http://maestro.idatalink.com/support)  
[www.12voltdata.com/forum](http://www.12voltdata.com/forum)

## TABLE OF CONTENTS

Wiring Diagram	<b>3</b>
Vehicle Wire Reference Chart	<b>4</b>

# WIRING DIAGRAM

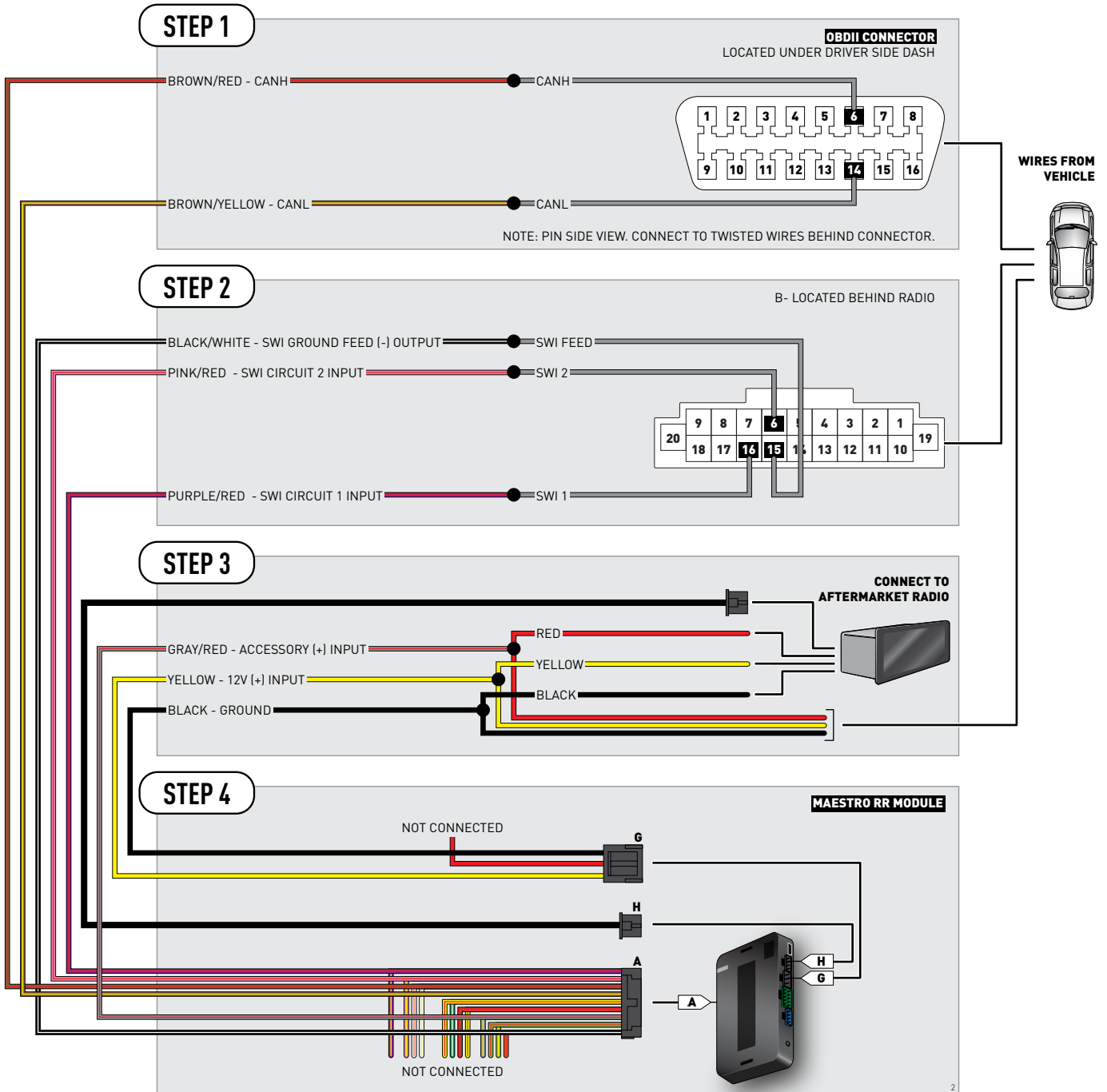



# VEHICLE WIRE REFERENCE CHART

Wire Description	Connector Name	Connector Color	Connector Type	Position	Wire Color	Polarity	Wire Location
CanH	A	~	16 pin	06	Blue	[DATA]	OBDII connector, under driver side dash
CanL	A	~	16 pin	14	Pink	[DATA]	OBDII connector, under driver side dash
SWI 1	B	~	20 pin	16	Blue	[DATA]	Behind radio
SWI 2	B		20 pin	06	Pink	[DATA]	Behind radio
SWI Feed	B	~	20 pin	15	LtGreen	(-)	Behind radio



# INSTALL GUIDE

# NISSAN SENTRA

# BASE

# 2013-2014

RETAINS STEERING WHEEL CONTROLS AND ADDS GAUGES



#### PRODUCTS REQUIRED

iDatalink Maestro RR Radio Replacement Interface  
iDatalink Compatible Radio

#### PROGRAMMED FIRMWARE

ADS-RR(SI)-NIS01-DS

#### OPTIONAL ACCESSORIES



Click here for:

[Radar Integration Installation Guide](#)

[Radar Integration Owner's Guide for Kenwood and JVC Radios](#)

# WELCOME

Congratulations on the purchase of your iDatalink Maestro RR Radio replacement solution. You are now a few simple steps away from enjoying your new car radio with enhanced features.

Before starting your installation, please ensure that your iDatalink Maestro module is programmed with the correct firmware for your vehicle and that you carefully review the install guide.

**Please note that Maestro RR will only retain functionalities that were originally available in the vehicle.**

# NEED HELP?

 **1 866 427-2999**

 [support@idatalink.com](mailto:support@idatalink.com)

 [maestro.idatalink.com/support](http://maestro.idatalink.com/support)  
[www.12voltdata.com/forum](http://www.12voltdata.com/forum)

## TABLE OF CONTENTS

Wiring Diagram	<b>3</b>
Vehicle Wire Reference Chart	<b>4</b>

# WIRING DIAGRAM



# VEHICLE WIRE REFERENCE CHART

Wire Description	Connector Name	Connector Color	Connector Type	Position	Wire Color	Polarity	Wire Location
CanH	A	~	16 pin	06	Blue	[DATA]	OBDII connector, under driver side dash
CanL	A	~	16 pin	14	Pink	[DATA]	OBDII connector, under driver side dash
SWI 1	B	~	20 pin	16	Red	[DATA]	Behind radio
SWI 2	B		20 pin	06	Green	[DATA]	Behind radio
SWI Feed	B	~	20 pin	15	Purple	(-)	Behind radio



# INSTALL GUIDE

# NISSAN SENTRA

# BLUETOOTH

# 2009-2012

RETAINS STEERING WHEEL CONTROLS AND ADDS GAUGES



#### PRODUCTS REQUIRED

iDatalink Maestro RR Radio Replacement Interface  
iDatalink Compatible Radio

#### PROGRAMMED FIRMWARE

ADS-RR(SI)-NIS01-DS

#### OPTIONAL ACCESSORIES



Click here for:

[Radar Integration Installation Guide](#)

[Radar Integration Owner's Guide for Kenwood and JVC Radios](#)

# WELCOME

Congratulations on the purchase of your iDatalink Maestro RR Radio replacement solution. You are now a few simple steps away from enjoying your new car radio with enhanced features.

Before starting your installation, please ensure that your iDatalink Maestro module is programmed with the correct firmware for your vehicle and that you carefully review the install guide.

**Please note that Maestro RR will only retain functionalities that were originally available in the vehicle.**

# NEED HELP?

 **1 866 427-2999**

 [support@idatalink.com](mailto:support@idatalink.com)

 [maestro.idatalink.com/support](http://maestro.idatalink.com/support)  
[www.12voltdata.com/forum](http://www.12voltdata.com/forum)

## TABLE OF CONTENTS

Wiring Diagram	<b>3</b>
Vehicle Wire Reference Chart	<b>4</b>

# WIRING DIAGRAM

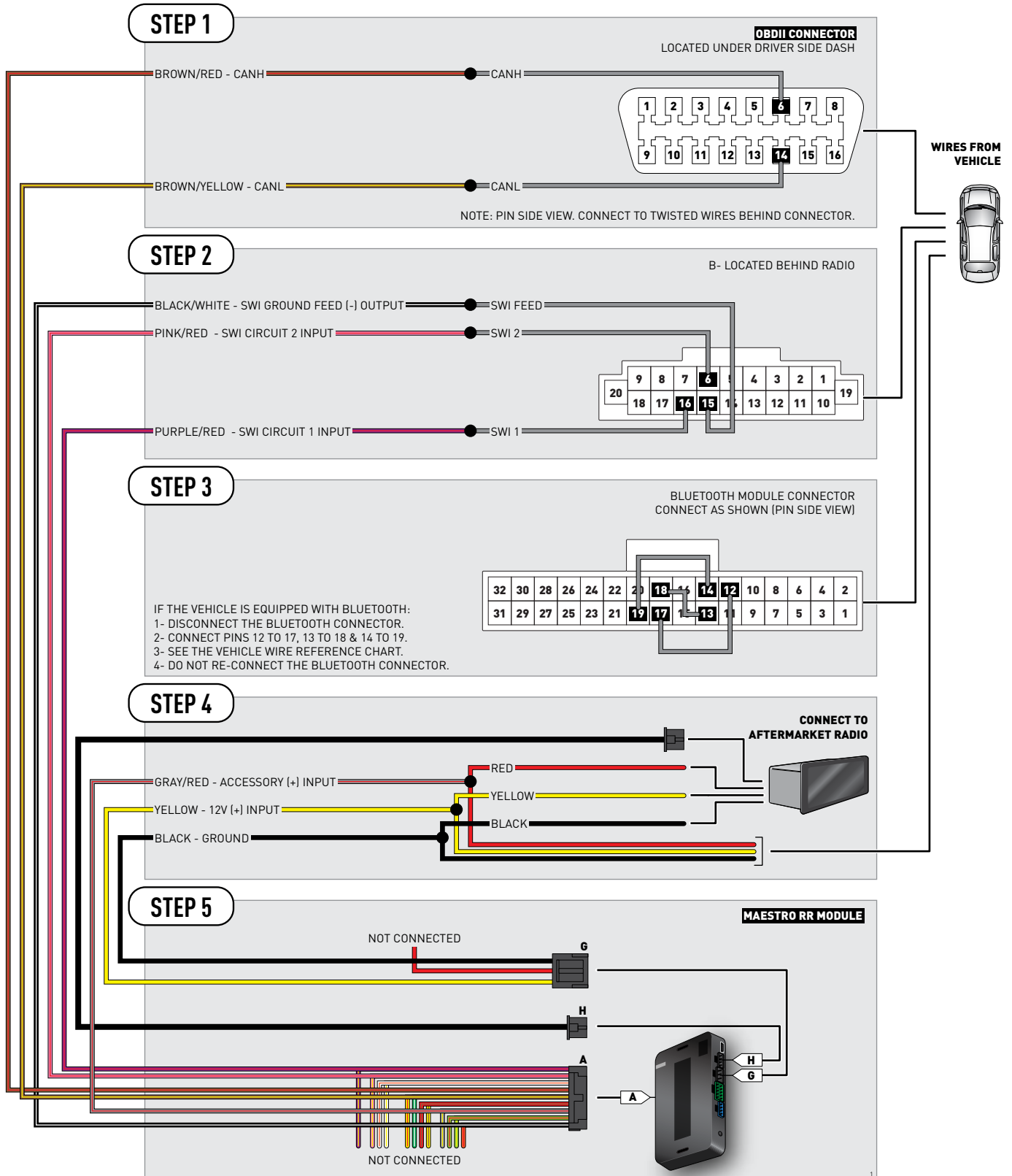



# VEHICLE WIRE REFERENCE CHART

Wire Description	Connector Name	Connector Color	Connector Type	Position	Wire Color	Polarity	Wire Location
CanH	A	~	16 pin	06	Blue	(DATA)	OBDII connector, under driver side dash
CanL	A	~	16 pin	14	Pink	(DATA)	OBDII connector, under driver side dash
SWI 1	B	~	20 pin	16	Blue	(DATA)	Behind radio
SWI 2	B		20 pin	06	Pink	(DATA)	Behind radio
SWI Feed	B	~	20 pin	15	LtGreen	(-)	Behind radio
BT-12	~	~	32 pin	12	Red/White	~	Under driver seat
BT-13	~	~	32 pin	13	Green/White	~	Under driver seat
BT-14	~	~	32 pin	14	White/Purple	~	Under driver seat
BT-17	~	~	32 pin	17	White/Red	~	Under driver seat
BT-18	~	~	32 pin	18	LtGreen/Black	~	Under driver seat
BT-19	~	~	32 pin	19	Purple/White	~	Under driver seat



# INSTALL GUIDE

# NISSAN SENTRA

# BLUETOOTH

# 2013-2014

RETAINS STEERING WHEEL CONTROLS AND ADDS GAUGES



#### PRODUCTS REQUIRED

iDatalink Maestro RR Radio Replacement Interface  
iDatalink Compatible Radio

#### PROGRAMMED FIRMWARE

ADS-RR(SI)-NIS01-DS

#### OPTIONAL ACCESSORIES



Click here for:

[Radar Integration Installation Guide](#)

[Radar Integration Owner's Guide for Kenwood and JVC Radios](#)

# WELCOME

Congratulations on the purchase of your iDatalink Maestro RR Radio replacement solution. You are now a few simple steps away from enjoying your new car radio with enhanced features.

Before starting your installation, please ensure that your iDatalink Maestro module is programmed with the correct firmware for your vehicle and that you carefully review the install guide.

**Please note that Maestro RR will only retain functionalities that were originally available in the vehicle.**

# NEED HELP?

 **1 866 427-2999**

 [support@idatalink.com](mailto:support@idatalink.com)

 [maestro.idatalink.com/support](http://maestro.idatalink.com/support)  
[www.12voltdata.com/forum](http://www.12voltdata.com/forum)

## TABLE OF CONTENTS

Wiring Diagram	<b>3</b>
Vehicle Wire Reference Chart	<b>4</b>

# WIRING DIAGRAM

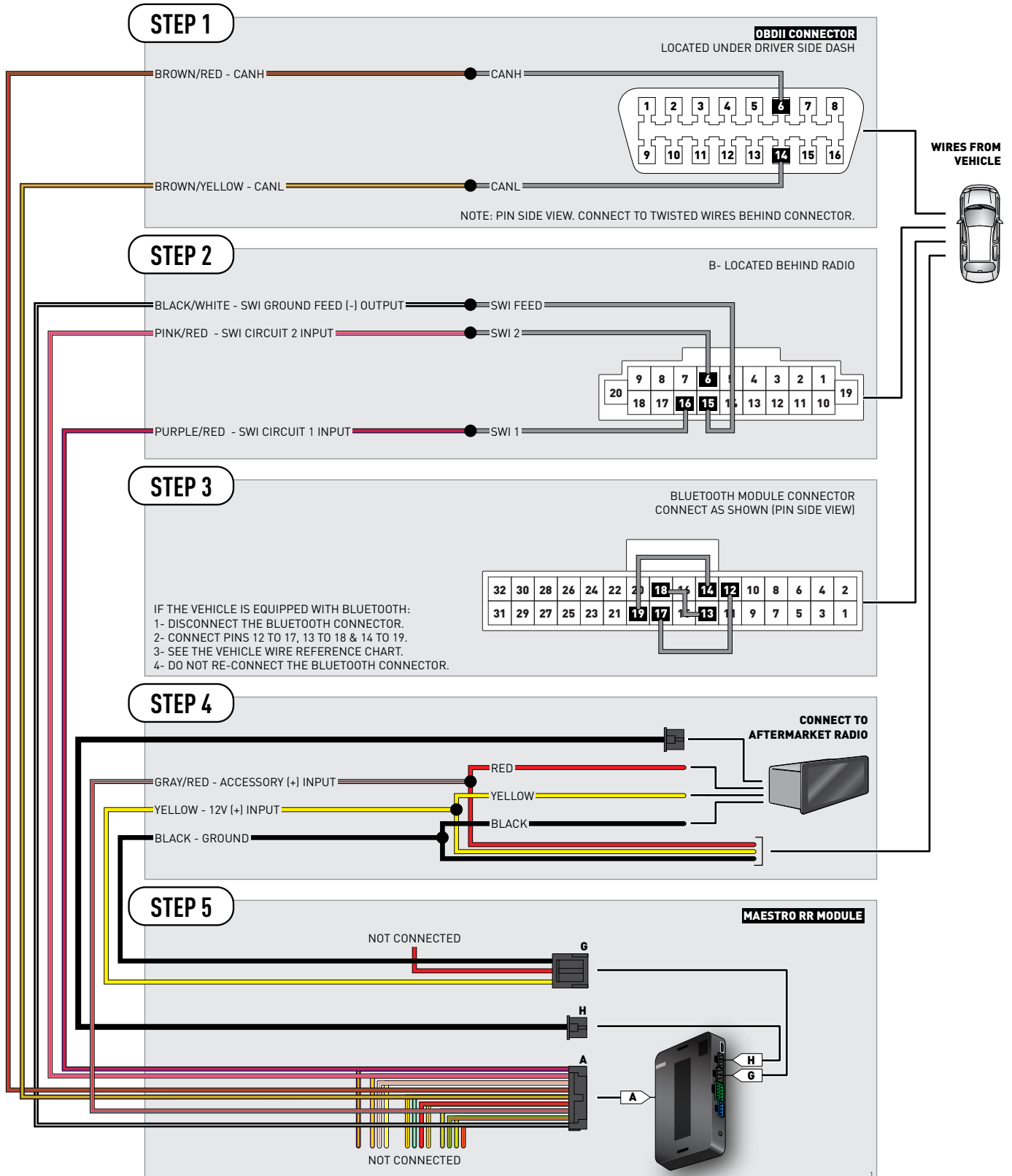

# VEHICLE WIRE REFERENCE CHART

Wire Description	Connector Name	Connector Color	Connector Type	Position	Wire Color	Polarity	Wire Location
CanH	A	~	16 pin	06	Blue	(DATA)	OBDII connector, under driver side dash
CanL	A	~	16 pin	14	Pink	(DATA)	OBDII connector, under driver side dash
SWI 1	B	~	20 pin	16	LtGreen	(DATA)	Behind radio
SWI 2	B		20 pin	06	Green	(DATA)	Behind radio
SWI Feed	B	~	20 pin	15	Pink	(-)	Behind radio
BT-12	~	~	32 pin	12	Green	~	Under driver seat
BT-13	~	~	32 pin	13	Red	~	Under driver seat
BT-14	~	~	32 pin	14	Purple or Blue	~	Under driver seat
BT-17	~	~	32 pin	17	Green	~	Under driver seat
BT-18	~	~	32 pin	18	LtGreen	~	Under driver seat
BT-19	~	~	32 pin	19	Pink	~	Under driver seat



# INSTALL GUIDE

# NISSAN SENTRA

# BLUETOOTH

# 2015-2018

RETAINS STEERING WHEEL CONTROLS AND ADDS GAUGES



#### PRODUCTS REQUIRED

iDatalink Maestro RR Radio Replacement Interface  
iDatalink Compatible Radio

#### PROGRAMMED FIRMWARE

ADS-RR(SI)-NIS01-DS

#### OPTIONAL ACCESSORIES



Click here for:

[Radar Integration Installation Guide](#)

[Radar Integration Owner's Guide for Kenwood and JVC Radios](#)

# WELCOME

Congratulations on the purchase of your iDatalink Maestro RR Radio replacement solution. You are now a few simple steps away from enjoying your new car radio with enhanced features.

Before starting your installation, please ensure that your iDatalink Maestro module is programmed with the correct firmware for your vehicle and that you carefully review the install guide.

**Please note that Maestro RR will only retain functionalities that were originally available in the vehicle.**

# NEED HELP?

 **1 866 427-2999**

 [support@idatalink.com](mailto:support@idatalink.com)

 [maestro.idatalink.com/support](http://maestro.idatalink.com/support)  
[www.12voltdata.com/forum](http://www.12voltdata.com/forum)

## TABLE OF CONTENTS

Wiring Diagram	<b>3</b>
Vehicle Wire Reference Chart	<b>4</b>

# WIRING DIAGRAM

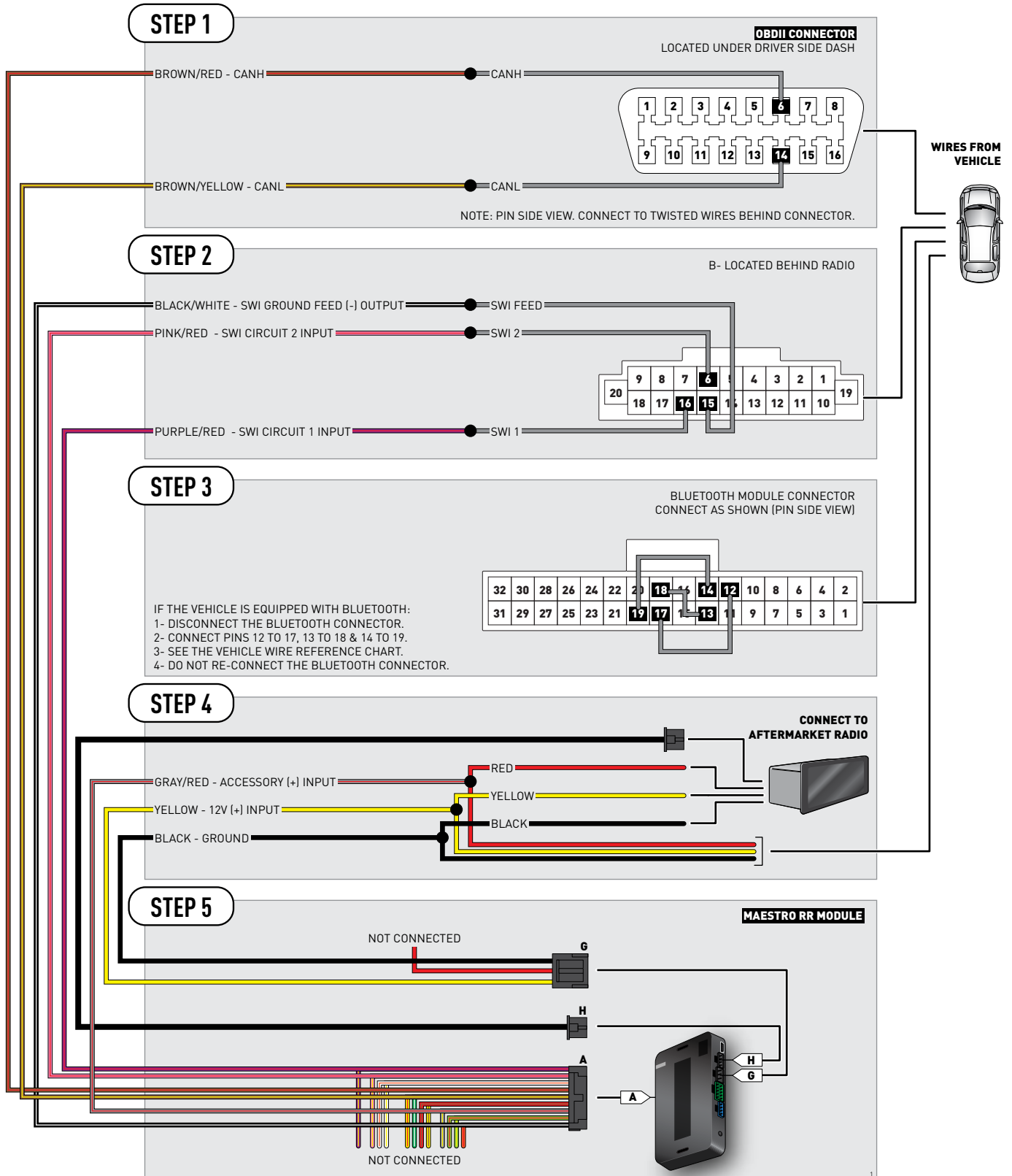



# VEHICLE WIRE REFERENCE CHART

Wire Description	Connector Name	Connector Color	Connector Type	Position	Wire Color	Polarity	Wire Location
CanH	A	~	16 pin	06	Blue	(DATA)	OBDII connector, under driver side dash
CanL	A	~	16 pin	14	Pink	(DATA)	OBDII connector, under driver side dash
SWI 1	B	~	20 pin	16	LtGreen	(DATA)	Behind radio
SWI 2	B		20 pin	06	Green	(DATA)	Behind radio
SWI Feed	B	~	20 pin	15	Pink	(-)	Behind radio
BT-12	~	~	32 pin	12	Green	~	Under driver seat
BT-13	~	~	32 pin	13	Red	~	Under driver seat
BT-14	~	~	32 pin	14	Purple or Blue	~	Under driver seat
BT-17	~	~	32 pin	17	Green	~	Under driver seat
BT-18	~	~	32 pin	18	LtGreen	~	Under driver seat
BT-19	~	~	32 pin	19	Pink	~	Under driver seat



# INSTALL GUIDE

# NISSAN SENTRA

# NAV AND BLUETOOTH

# 2010-2012

RETAINS STEERING WHEEL CONTROLS AND ADDS GAUGES



#### PRODUCTS REQUIRED

iDatalink Maestro RR Radio Replacement Interface  
iDatalink Compatible Radio

#### PROGRAMMED FIRMWARE

ADS-RR(SI)-NIS01-DS

#### OPTIONAL ACCESSORIES



Click here for:

[Radar Integration Installation Guide](#)

[Radar Integration Owner's Guide for Kenwood and JVC Radios](#)

# WELCOME

Congratulations on the purchase of your iDatalink Maestro RR Radio replacement solution. You are now a few simple steps away from enjoying your new car radio with enhanced features.

Before starting your installation, please ensure that your iDatalink Maestro module is programmed with the correct firmware for your vehicle and that you carefully review the install guide.

**Please note that Maestro RR will only retain functionalities that were originally available in the vehicle.**

# NEED HELP?

 **1 866 427-2999**

 [support@idatalink.com](mailto:support@idatalink.com)

 [maestro.idatalink.com/support](http://maestro.idatalink.com/support)  
[www.12voltdata.com/forum](http://www.12voltdata.com/forum)

## TABLE OF CONTENTS

Wiring Diagram	<b>3</b>
Vehicle Wire Reference Chart	<b>4</b>

# WIRING DIAGRAM



# VEHICLE WIRE REFERENCE CHART

Wire Description	Connector Name	Connector Color	Connector Type	Position	Wire Color	Polarity	Wire Location
CanH	A	~	16 pin	06	Blue	[DATA]	OBDII connector, under driver side dash
CanL	A	~	16 pin	14	Pink	[DATA]	OBDII connector, under driver side dash
SWI 1	B	~	20 pin	16	Blue	[DATA]	Behind radio
SWI 2	B		20 pin	06	Pink	[DATA]	Behind radio
SWI Feed	B	~	20 pin	15	LtGreen	(-)	Behind radio



# INSTALL GUIDE

# NISSAN SENTRA

# NAV AND BLUETOOTH

# 2013-2014

RETAINS STEERING WHEEL CONTROLS AND ADDS GAUGES



#### PRODUCTS REQUIRED

iDatalink Maestro RR Radio Replacement Interface  
iDatalink Compatible Radio

#### PROGRAMMED FIRMWARE

ADS-RR(SI)-NIS01-DS

#### OPTIONAL ACCESSORIES



Click here for:

[Radar Integration Installation Guide](#)

[Radar Integration Owner's Guide for Kenwood and JVC Radios](#)

# WELCOME

Congratulations on the purchase of your iDatalink Maestro RR Radio replacement solution. You are now a few simple steps away from enjoying your new car radio with enhanced features.

Before starting your installation, please ensure that your iDatalink Maestro module is programmed with the correct firmware for your vehicle and that you carefully review the install guide.

**Please note that Maestro RR will only retain functionalities that were originally available in the vehicle.**

# NEED HELP?

 **1 866 427-2999**

 [support@idatalink.com](mailto:support@idatalink.com)

 [maestro.idatalink.com/support](http://maestro.idatalink.com/support)  
[www.12voltdata.com/forum](http://www.12voltdata.com/forum)

## TABLE OF CONTENTS

Wiring Diagram	<b>3</b>
Vehicle Wire Reference Chart	<b>4</b>

# WIRING DIAGRAM

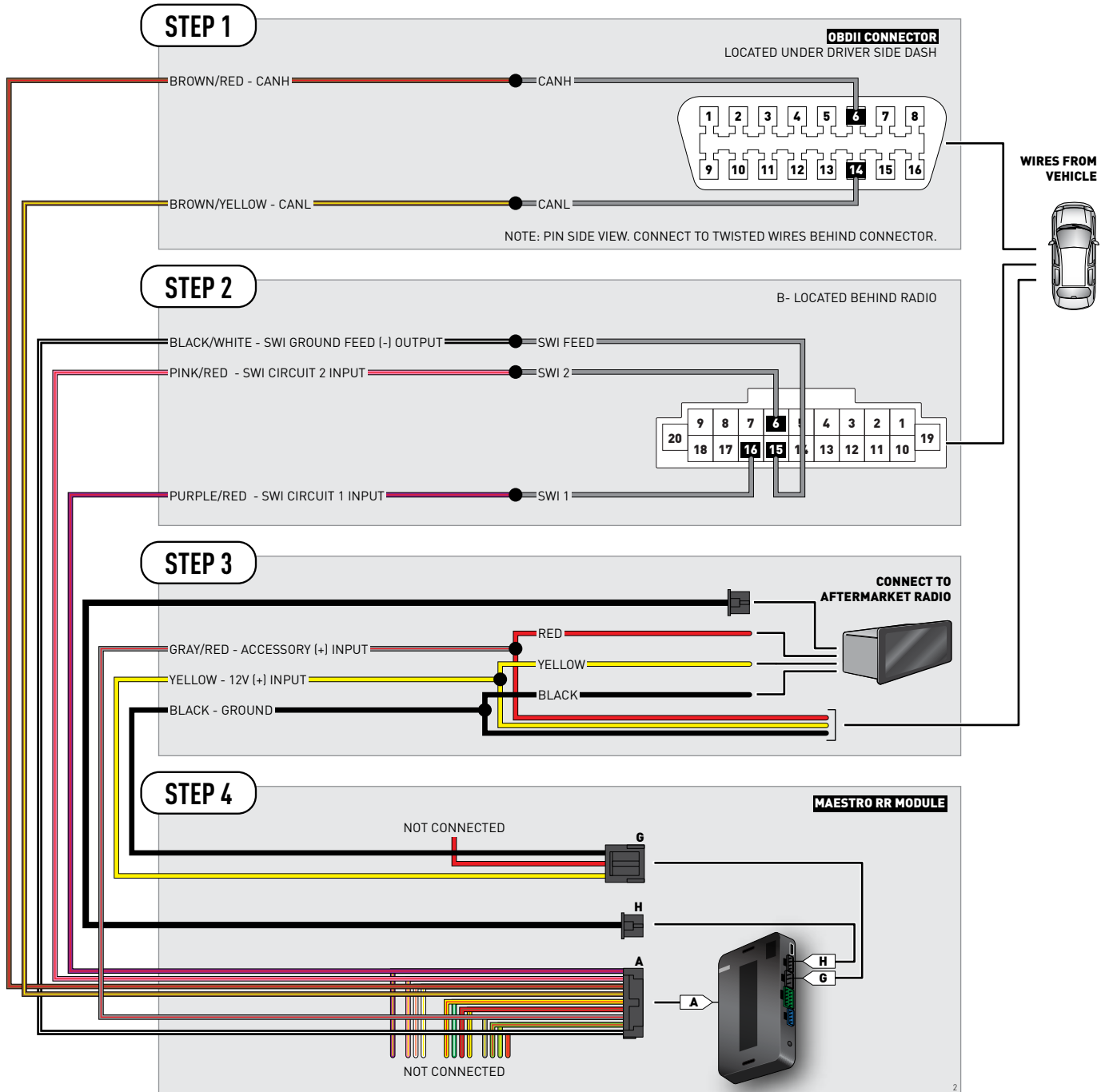



# VEHICLE WIRE REFERENCE CHART

Wire Description	Connector Name	Connector Color	Connector Type	Position	Wire Color	Polarity	Wire Location
CanH	A	~	16 pin	06	Blue	[DATA]	OBDII connector, under driver side dash
CanL	A	~	16 pin	14	Pink	[DATA]	OBDII connector, under driver side dash
SWI 1	B	~	20 pin	16	Red	[DATA]	Behind radio
SWI 2	B		20 pin	06	Green	[DATA]	Behind radio
SWI Feed	B	~	20 pin	15	Purple	(-)	Behind radio



# INSTALL GUIDE

# NISSAN SENTRA

# NAV AND BLUETOOTH

# 2015-2018

RETAINS STEERING WHEEL CONTROLS AND ADDS GAUGES



#### PRODUCTS REQUIRED

iDatalink Maestro RR Radio Replacement Interface  
iDatalink Compatible Radio

#### PROGRAMMED FIRMWARE

ADS-RR(SI)-NIS01-DS

#### OPTIONAL ACCESSORIES



Click here for:

[Radar Integration Installation Guide](#)

[Radar Integration Owner's Guide for Kenwood and JVC Radios](#)

# WELCOME

Congratulations on the purchase of your iDatalink Maestro RR Radio replacement solution. You are now a few simple steps away from enjoying your new car radio with enhanced features.

Before starting your installation, please ensure that your iDatalink Maestro module is programmed with the correct firmware for your vehicle and that you carefully review the install guide.

**Please note that Maestro RR will only retain functionalities that were originally available in the vehicle.**

# NEED HELP?

 **1 866 427-2999**

 [support@idatalink.com](mailto:support@idatalink.com)

 [maestro.idatalink.com/support](http://maestro.idatalink.com/support)  
[www.12voltdata.com/forum](http://www.12voltdata.com/forum)

## TABLE OF CONTENTS

Wiring Diagram	<b>3</b>
Vehicle Wire Reference Chart	<b>4</b>

# WIRING DIAGRAM



# VEHICLE WIRE REFERENCE CHART

Wire Description	Connector Name	Connector Color	Connector Type	Position	Wire Color	Polarity	Wire Location
CanH	A	~	16 pin	06	Blue	[DATA]	OBDII connector, under driver side dash
CanL	A	~	16 pin	14	Pink	[DATA]	OBDII connector, under driver side dash
SWI 1	B	~	20 pin	16	Red	[DATA]	Behind radio
SWI 2	B		20 pin	06	Green	[DATA]	Behind radio
SWI Feed	B	~	20 pin	15	Purple	(-)	Behind radio



# INSTALL GUIDE

# NISSAN SENTRA

# WITH BOSE AND BLUETOOTH

# 2015-2018

RETAINS STEERING WHEEL CONTROLS AND ADDS GAUGES



#### PRODUCTS REQUIRED

iDatalink Maestro RR Radio Replacement Interface  
iDatalink Compatible Radio

#### PROGRAMMED FIRMWARE

ADS-RR(SI)-NIS01-DS

#### OPTIONAL ACCESSORIES



Click here for:

[Radar Integration Installation Guide](#)

[Radar Integration Owner's Guide for Kenwood and JVC Radios](#)

# WELCOME

Congratulations on the purchase of your iDatalink Maestro RR Radio replacement solution. You are now a few simple steps away from enjoying your new car radio with enhanced features.

Before starting your installation, please ensure that your iDatalink Maestro module is programmed with the correct firmware for your vehicle and that you carefully review the install guide.

**Please note that Maestro RR will only retain functionalities that were originally available in the vehicle.**

# NEED HELP?

 **1 866 427-2999**

 [support@idatalink.com](mailto:support@idatalink.com)

 [maestro.idatalink.com/support](http://maestro.idatalink.com/support)  
[www.12voltdata.com/forum](http://www.12voltdata.com/forum)

## TABLE OF CONTENTS

Wiring Diagram	<b>3</b>
Vehicle Wire Reference Chart	<b>4</b>

# WIRING DIAGRAM

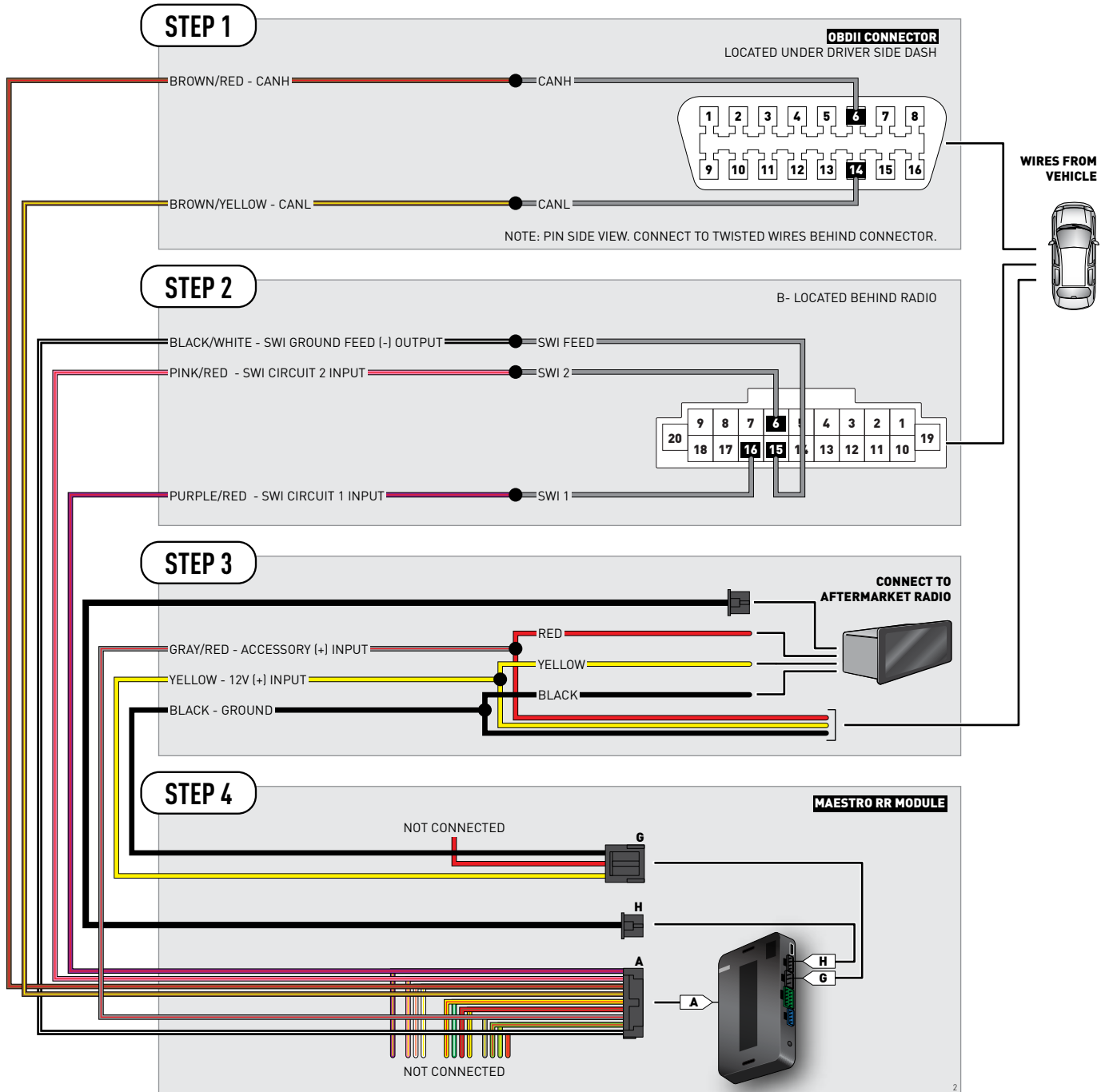



# VEHICLE WIRE REFERENCE CHART

Wire Description	Connector Name	Connector Color	Connector Type	Position	Wire Color	Polarity	Wire Location
CanH	A	~	16 pin	06	Blue	[DATA]	OBDII connector, under driver side dash
CanL	A	~	16 pin	14	Pink	[DATA]	OBDII connector, under driver side dash
SWI 1	B	~	20 pin	16	Red	[DATA]	Behind radio
SWI 2	B		20 pin	06	Green	[DATA]	Behind radio
SWI Feed	B	~	20 pin	15	Purple	(-)	Behind radio



# INSTALL GUIDE NISSAN TITAN

## 2009-2012

RETAINS STEERING WHEEL CONTROLS AND ADDS GAUGES



### PRODUCTS REQUIRED

iDatalink Maestro RR Radio Replacement Interface  
iDatalink Compatible Radio

### PROGRAMMED FIRMWARE

ADS-RR(SI)-NIS01-DS

### OPTIONAL ACCESSORIES



Click here for:

[Radar Integration Installation Guide](#)

[Radar Integration Owner's Guide for Kenwood and JVC Radios](#)

# WELCOME

Congratulations on the purchase of your iDatalink Maestro RR Radio replacement solution. You are now a few simple steps away from enjoying your new car radio with enhanced features.

Before starting your installation, please ensure that your iDatalink Maestro module is programmed with the correct firmware for your vehicle and that you carefully review the install guide.

**Please note that Maestro RR will only retain functionalities that were originally available in the vehicle.**

# NEED HELP?

 **1 866 427-2999**

 [support@idatalink.com](mailto:support@idatalink.com)

 [maestro.idatalink.com/support](http://maestro.idatalink.com/support)  
[www.12voltdata.com/forum](http://www.12voltdata.com/forum)

## TABLE OF CONTENTS

Wiring Diagram	<b>3</b>
Vehicle Wire Reference Chart	<b>4</b>

# WIRING DIAGRAM

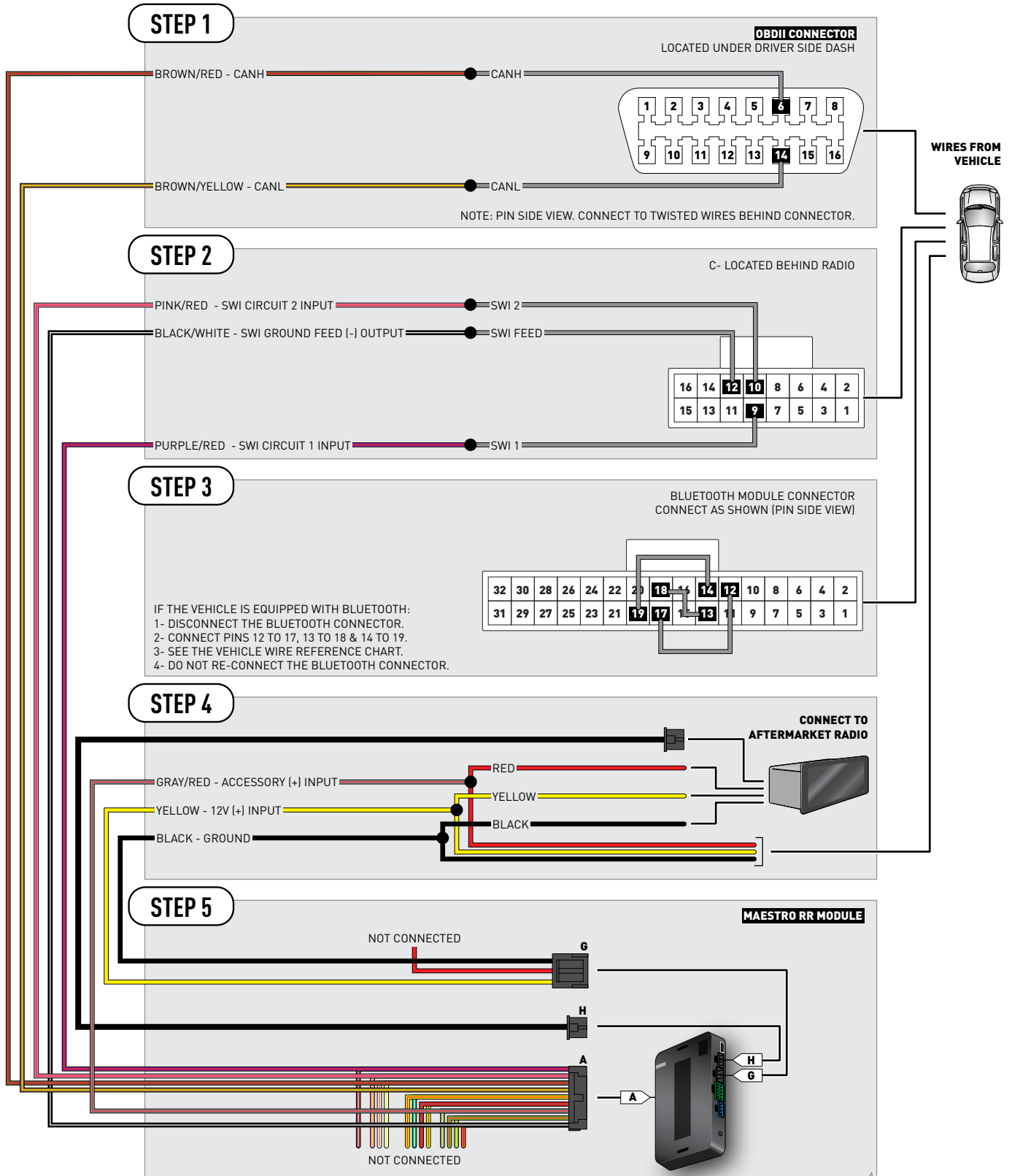

# VEHICLE WIRE REFERENCE CHART

Wire Description	Connector Name	Connector Color	Connector Type	Position	Wire Color	Polarity	Wire Location
CanH	A	~	16 pin	06	Blue	(DATA)	OBDII connector, under driver side dash
CanL	A	~	16 pin	14	Pink	(DATA)	OBDII connector, under driver side dash
SWI 1	C	~	16 pin	09	Green or Green/White	(DATA)	Behind radio
SWI 2	C		16 pin	10	Red or Red/Green	(DATA)	Behind radio
SWI Feed	C	~	16 pin	12	Blue or Yellow/Red	(-)	Behind radio
BT-12	~	~	32 pin	12	Red	~	Under passenger seat
BT-13	~	~	32 pin	13	Green	~	Under passenger seat
BT-14	~	~	32 pin	14	Blue	~	Under passenger seat
BT-17	~	~	32 pin	17	Red/Green	~	Under passenger seat
BT-18	~	~	32 pin	18	Green/White	~	Under passenger seat
BT-19	~	~	32 pin	19	Yellow/Red	~	Under passenger seat

iDatalink  
**maestro RR**

# INSTALL GUIDE NISSAN TITAN

## 2015

RETAINS STEERING WHEEL CONTROLS AND ADDS GAUGES



#### PRODUCTS REQUIRED

iDatalink Maestro RR Radio Replacement Interface  
iDatalink Compatible Radio

#### PROGRAMMED FIRMWARE

ADS-RR(SI)-NIS01-DS

#### OPTIONAL ACCESSORIES

**K40**<sup>™</sup>  
ELECTRONICS

Click here for:

[Radar Integration Installation Guide](#)

[Radar Integration Owner's Guide for Kenwood and JVC Radios](#)

# WELCOME

Congratulations on the purchase of your iDatalink Maestro RR Radio replacement solution. You are now a few simple steps away from enjoying your new car radio with enhanced features.

Before starting your installation, please ensure that your iDatalink Maestro module is programmed with the correct firmware for your vehicle and that you carefully review the install guide.

**Please note that Maestro RR will only retain functionalities that were originally available in the vehicle.**

# NEED HELP?

 **1 866 427-2999**

 [support@idatalink.com](mailto:support@idatalink.com)

 [maestro.idatalink.com/support](http://maestro.idatalink.com/support)  
[www.12voltdata.com/forum](http://www.12voltdata.com/forum)

## TABLE OF CONTENTS

Wiring Diagram	<b>3</b>
Vehicle Wire Reference Chart	<b>4</b>

# WIRING DIAGRAM

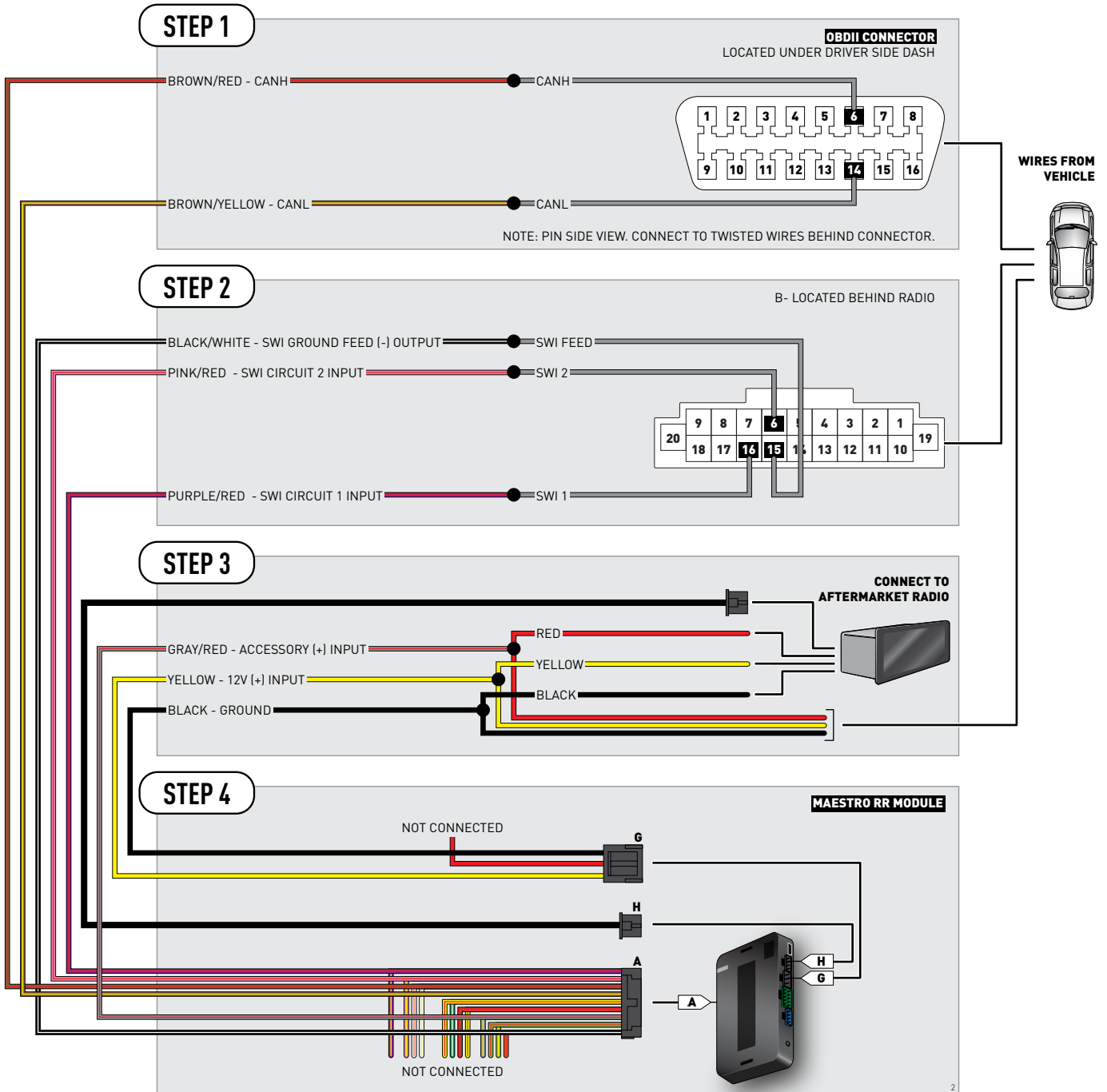



# VEHICLE WIRE REFERENCE CHART

Wire Description	Connector Name	Connector Color	Connector Type	Position	Wire Color	Polarity	Wire Location
CanH	A	~	16 pin	06	Blue	[DATA]	OBDII connector, under driver side dash
CanL	A	~	16 pin	14	Pink	[DATA]	OBDII connector, under driver side dash
SWI 1	B	~	20 pin	16	Green or Green/White	[DATA]	Behind radio
SWI 2	B	~	20 pin	06	Red or Red/Green	[DATA]	Behind radio
SWI Feed	B	~	20 pin	15	Blue or Yellow or Yellow/Red	(-)	Behind radio



# INSTALL GUIDE

# NISSAN TITAN

# BASE

# 2013-2014

RETAINS STEERING WHEEL CONTROLS AND ADDS GAUGES



#### PRODUCTS REQUIRED

iDatalink Maestro RR Radio Replacement Interface  
iDatalink Compatible Radio

#### PROGRAMMED FIRMWARE

ADS-RR(SI)-NIS01-DS

#### OPTIONAL ACCESSORIES



Click here for:

[Radar Integration Installation Guide](#)

[Radar Integration Owner's Guide for Kenwood and JVC Radios](#)

# WELCOME

Congratulations on the purchase of your iDatalink Maestro RR Radio replacement solution. You are now a few simple steps away from enjoying your new car radio with enhanced features.

Before starting your installation, please ensure that your iDatalink Maestro module is programmed with the correct firmware for your vehicle and that you carefully review the install guide.

**Please note that Maestro RR will only retain functionalities that were originally available in the vehicle.**

# NEED HELP?

 **1 866 427-2999**

 [support@idatalink.com](mailto:support@idatalink.com)

 [maestro.idatalink.com/support](http://maestro.idatalink.com/support)  
[www.12voltdata.com/forum](http://www.12voltdata.com/forum)

## TABLE OF CONTENTS

Wiring Diagram	<b>3</b>
Vehicle Wire Reference Chart	<b>4</b>

# WIRING DIAGRAM



# VEHICLE WIRE REFERENCE CHART

Wire Description	Connector Name	Connector Color	Connector Type	Position	Wire Color	Polarity	Wire Location
CanH	A	~	16 pin	06	Blue	[DATA]	OBDII connector, under driver side dash
CanL	A	~	16 pin	14	Pink	[DATA]	OBDII connector, under driver side dash
SWI 1	B	~	20 pin	16	Green	[DATA]	Behind radio
SWI 2	B	~	20 pin	06	Red	[DATA]	Behind radio
SWI Feed	B	~	20 pin	15	Blue	(-)	Behind radio



# INSTALL GUIDE NISSAN TITAN BLUETOOTH 2013-2014

RETAINS STEERING WHEEL CONTROLS AND ADDS GAUGES



#### PRODUCTS REQUIRED

iDatalink Maestro RR Radio Replacement Interface  
iDatalink Compatible Radio

#### PROGRAMMED FIRMWARE

ADS-RR(SI)-NIS01-DS

#### OPTIONAL ACCESSORIES



Click here for:

[Radar Integration Installation Guide](#)

[Radar Integration Owner's Guide for Kenwood and JVC Radios](#)

# WELCOME

Congratulations on the purchase of your iDatalink Maestro RR Radio replacement solution. You are now a few simple steps away from enjoying your new car radio with enhanced features.

Before starting your installation, please ensure that your iDatalink Maestro module is programmed with the correct firmware for your vehicle and that you carefully review the install guide.

**Please note that Maestro RR will only retain functionalities that were originally available in the vehicle.**

# NEED HELP?

 **1 866 427-2999**

 [support@idatalink.com](mailto:support@idatalink.com)

 [maestro.idatalink.com/support](http://maestro.idatalink.com/support)  
[www.12voltdata.com/forum](http://www.12voltdata.com/forum)

## TABLE OF CONTENTS

Wiring Diagram	<b>3</b>
Vehicle Wire Reference Chart	<b>4</b>

# WIRING DIAGRAM

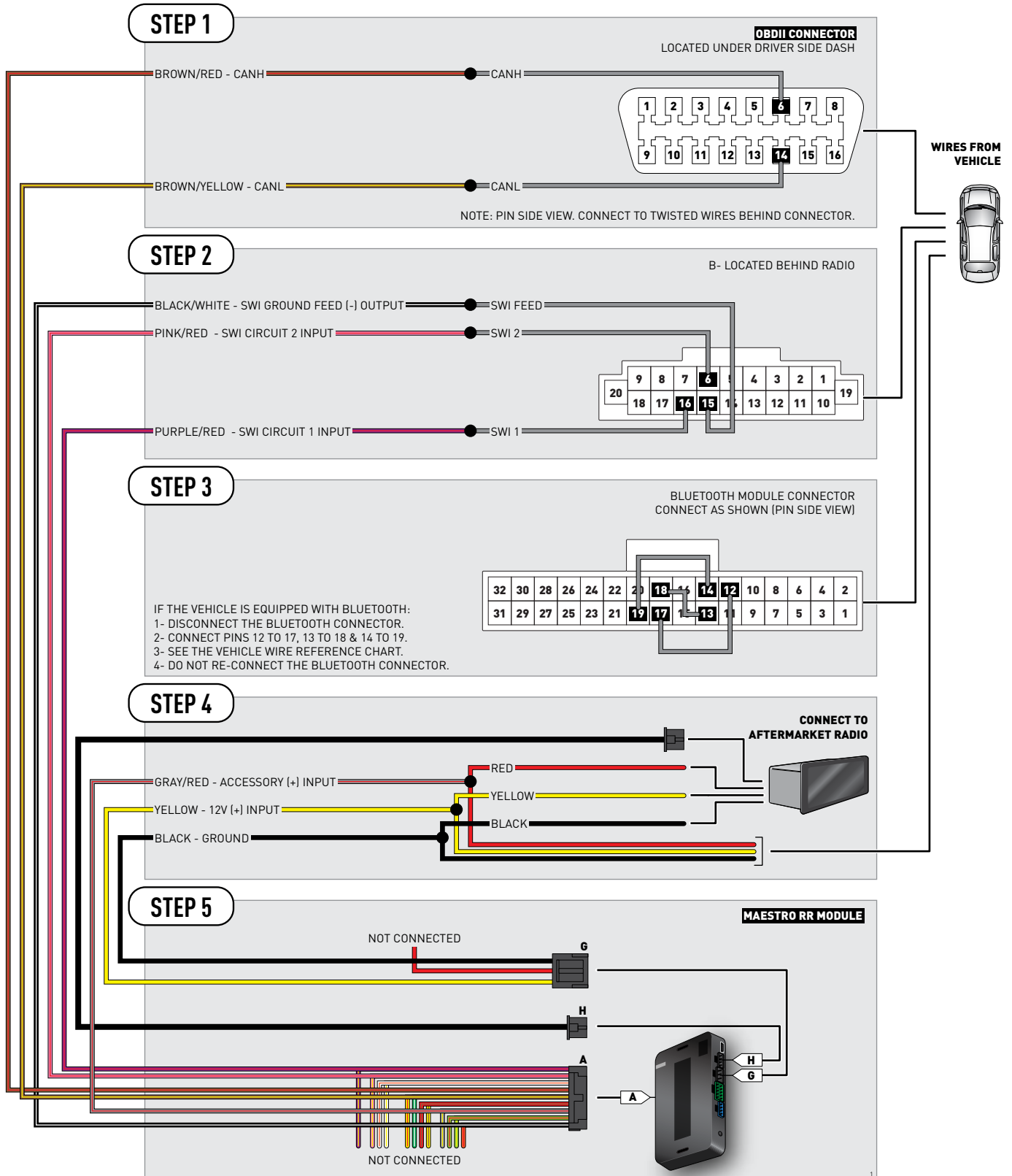



# VEHICLE WIRE REFERENCE CHART

Wire Description	Connector Name	Connector Color	Connector Type	Position	Wire Color	Polarity	Wire Location
CanH	A	~	16 pin	06	Blue	(DATA)	OBDII connector, under driver side dash
CanL	A	~	16 pin	14	Pink	(DATA)	OBDII connector, under driver side dash
SWI 1	B	~	20 pin	16	Green/Orange	(DATA)	Behind radio
SWI 2	B	~	20 pin	06	Purple	(DATA)	Behind radio
SWI Feed	B	~	20 pin	15	Red/Black	(-)	Behind radio
BT-12	~	~	32 pin	12	Red /Green	~	Under passenger seat
BT-13	~	~	32 pin	13	Green/White	~	Under passenger seat
BT-14	~	~	32 pin	14	Yellow/Red	~	Under passenger seat
BT-17	~	~	32 pin	17	Purple	~	Under passenger seat
BT-18	~	~	32 pin	18	Green/Orange	~	Under passenger seat
BT-19	~	~	32 pin	19	Red/Black	~	Under passenger seat



# INSTALL GUIDE

# NISSAN TITAN

# NAV AND BLUETOOTH

# 2013-2014

RETAINS STEERING WHEEL CONTROLS AND ADDS GAUGES



#### PRODUCTS REQUIRED

iDatalink Maestro RR Radio Replacement Interface  
iDatalink Compatible Radio

#### PROGRAMMED FIRMWARE

ADS-RR(SI)-NIS01-DS

#### OPTIONAL ACCESSORIES



Click here for:

[Radar Integration Installation Guide](#)

[Radar Integration Owner's Guide for Kenwood and JVC Radios](#)

# WELCOME

Congratulations on the purchase of your iDatalink Maestro RR Radio replacement solution. You are now a few simple steps away from enjoying your new car radio with enhanced features.

Before starting your installation, please ensure that your iDatalink Maestro module is programmed with the correct firmware for your vehicle and that you carefully review the install guide.

**Please note that Maestro RR will only retain functionalities that were originally available in the vehicle.**

# NEED HELP?

 **1 866 427-2999**

 [support@idatalink.com](mailto:support@idatalink.com)

 [maestro.idatalink.com/support](http://maestro.idatalink.com/support)  
[www.12voltdata.com/forum](http://www.12voltdata.com/forum)

## TABLE OF CONTENTS

Wiring Diagram	<b>3</b>
Vehicle Wire Reference Chart	<b>4</b>

# WIRING DIAGRAM



# VEHICLE WIRE REFERENCE CHART

Wire Description	Connector Name	Connector Color	Connector Type	Position	Wire Color	Polarity	Wire Location
CanH	A	~	16 pin	06	Blue	[DATA]	OBDII connector, under driver side dash
CanL	A	~	16 pin	14	Pink	[DATA]	OBDII connector, under driver side dash
SWI 1	B	~	20 pin	16	Green	[DATA]	Behind radio
SWI 2	B	~	20 pin	06	Red	[DATA]	Behind radio
SWI Feed	B	~	20 pin	15	Blue	(-)	Behind radio



# INSTALL GUIDE

# NISSAN

# VERSA AND VERSA HATCHBACK

# BLUETOOTH

# 2009-2011

RETAINS STEERING WHEEL CONTROLS AND ADDS GAUGES



#### PRODUCTS REQUIRED

iDatalink Maestro RR Radio Replacement Interface  
iDatalink Compatible Radio

#### PROGRAMMED FIRMWARE

ADS-RR(SI)-NIS01-DS

#### OPTIONAL ACCESSORIES



Click here for:

[Radar Integration Installation Guide](#)

[Radar Integration Owner's Guide for Kenwood and JVC Radios](#)

# WELCOME

Congratulations on the purchase of your iDatalink Maestro RR Radio replacement solution. You are now a few simple steps away from enjoying your new car radio with enhanced features.

Before starting your installation, please ensure that your iDatalink Maestro module is programmed with the correct firmware for your vehicle and that you carefully review the install guide.

**Please note that Maestro RR will only retain functionalities that were originally available in the vehicle.**

# NEED HELP?

 **1 866 427-2999**

 **support@idatalink.com**

 **maestro.idatalink.com/support**  
**www.12voltdata.com/forum**

## TABLE OF CONTENTS

Wiring Diagram	<b>3</b>
Vehicle Wire Reference Chart	<b>4</b>

# WIRING DIAGRAM

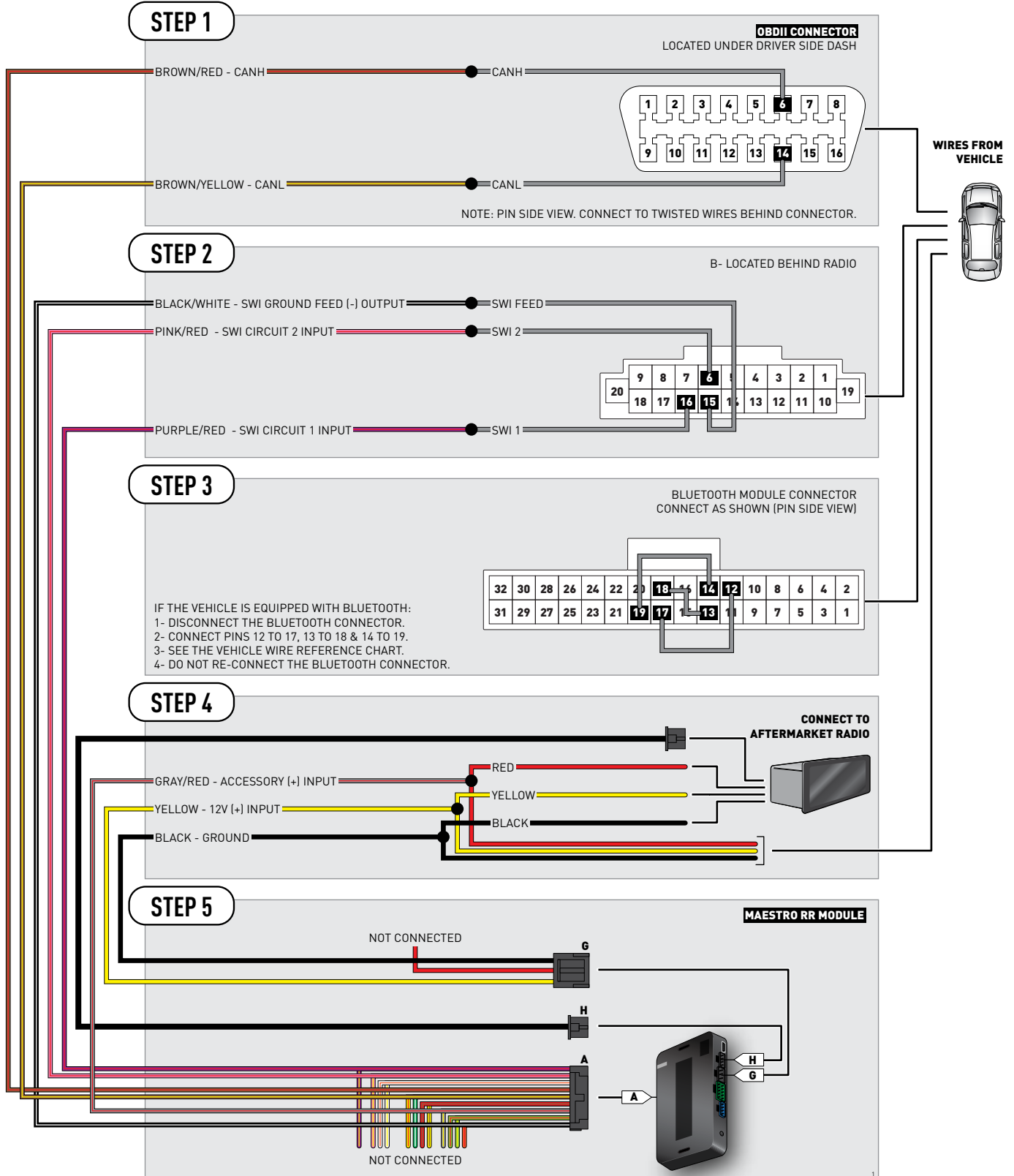



# VEHICLE WIRE REFERENCE CHART

Wire Description	Connector Name	Connector Color	Connector Type	Position	Wire Color	Polarity	Wire Location
CanH	A	~	16 pin	06	Blue	(DATA)	OBDII connector, under driver side dash
CanL	A	~	16 pin	14	Pink	(DATA)	OBDII connector, under driver side dash
SWI 1	B	~	20 pin	16	Pink	(DATA)	Behind radio
SWI 2	B		20 pin	06	Blue	(DATA)	Behind radio
SWI Feed	B	~	20 pin	15	Black	(-)	Behind radio
BT-12	~	~	32 pin	12	White	~	Trunk, right side
BT-13	~	~	32 pin	13	Blue	~	Trunk, right side
BT-14	~	~	32 pin	14	Black	~	Trunk, right side
BT-17	~	~	32 pin	17	Gray	~	Trunk, right side
BT-18	~	~	32 pin	18	Pink	~	Trunk, right side
BT-19	~	~	32 pin	19	Black	~	Trunk, right side

iDATALINK  
maestro *RR*

INSTALL GUIDE  
**NISSAN**  
**VERSA AND VERSA HATCHBACK**  
**NAV AND BLUETOOTH**  
**2010-2011**

RETAINS STEERING WHEEL CONTROLS AND ADDS GAUGES



**PRODUCTS REQUIRED**

iDatalink Maestro RR Radio Replacement Interface  
iDatalink Compatible Radio

**PROGRAMMED FIRMWARE**

ADS-RR(SI)-NIS01-DS

**OPTIONAL ACCESSORIES**

**K40**<sup>TM</sup>  
ELECTRONICS

Click here for:

[Radar Integration Installation Guide](#)

[Radar Integration Owner's Guide for Kenwood and JVC Radios](#)

# WELCOME

Congratulations on the purchase of your iDatalink Maestro RR Radio replacement solution. You are now a few simple steps away from enjoying your new car radio with enhanced features.

Before starting your installation, please ensure that your iDatalink Maestro module is programmed with the correct firmware for your vehicle and that you carefully review the install guide.

**Please note that Maestro RR will only retain functionalities that were originally available in the vehicle.**

# NEED HELP?

 **1 866 427-2999**

 [support@idatalink.com](mailto:support@idatalink.com)

 [maestro.idatalink.com/support](http://maestro.idatalink.com/support)  
[www.12voltdata.com/forum](http://www.12voltdata.com/forum)

## TABLE OF CONTENTS

Wiring Diagram	<b>3</b>
Vehicle Wire Reference Chart	<b>4</b>

# WIRING DIAGRAM



# VEHICLE WIRE REFERENCE CHART

Wire Description	Connector Name	Connector Color	Connector Type	Position	Wire Color	Polarity	Wire Location
CanH	A	~	16 pin	06	Blue	[DATA]	OBDII connector, under driver side dash
CanL	A	~	16 pin	14	Pink	[DATA]	OBDII connector, under driver side dash
SWI 1	B	~	20 pin	16	Pink	[DATA]	Behind radio
SWI 2	B		20 pin	06	Blue	[DATA]	Behind radio
SWI Feed	B	~	20 pin	15	Black	(-)	Behind radio



# INSTALL GUIDE

# NISSAN VERSA

# BLUETOOTH

# 2012-2018

RETAINS STEERING WHEEL CONTROLS AND ADDS GAUGES



#### PRODUCTS REQUIRED

iDatalink Maestro RR Radio Replacement Interface  
iDatalink Compatible Radio

#### PROGRAMMED FIRMWARE

ADS-RR(SI)-NIS01-DS

#### OPTIONAL ACCESSORIES



Click here for:

[Radar Integration Installation Guide](#)

[Radar Integration Owner's Guide for Kenwood and JVC Radios](#)

# WELCOME

Congratulations on the purchase of your iDatalink Maestro RR Radio replacement solution. You are now a few simple steps away from enjoying your new car radio with enhanced features.

Before starting your installation, please ensure that your iDatalink Maestro module is programmed with the correct firmware for your vehicle and that you carefully review the install guide.

**Please note that Maestro RR will only retain functionalities that were originally available in the vehicle.**

# NEED HELP?

 **1 866 427-2999**

 [support@idatalink.com](mailto:support@idatalink.com)

 [maestro.idatalink.com/support](http://maestro.idatalink.com/support)  
[www.12voltdata.com/forum](http://www.12voltdata.com/forum)

## TABLE OF CONTENTS

Wiring Diagram	<b>3</b>
Vehicle Wire Reference Chart	<b>4</b>

# WIRING DIAGRAM

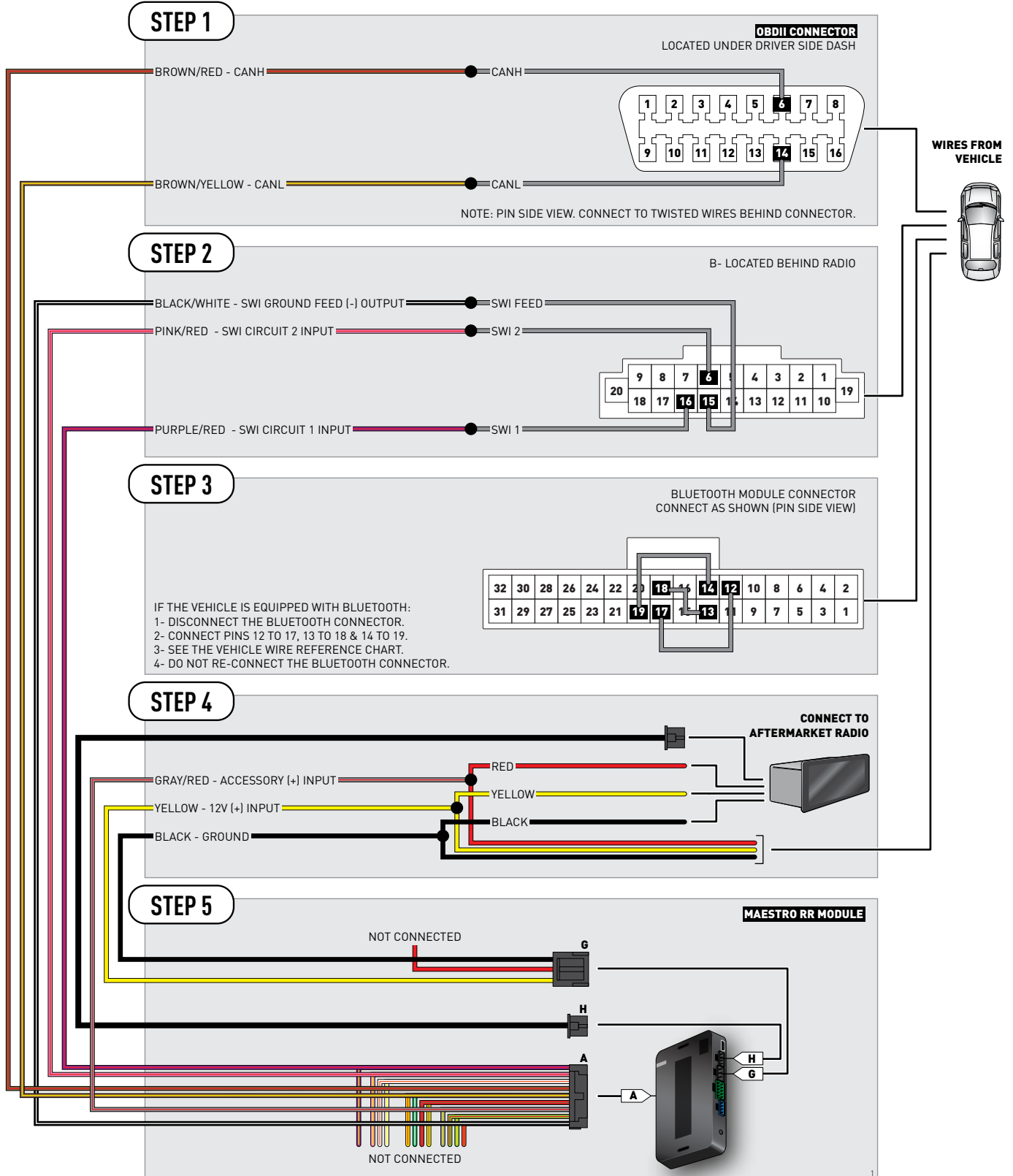



# VEHICLE WIRE REFERENCE CHART

Wire Description	Connector Name	Connector Color	Connector Type	Position	Wire Color	Polarity	Wire Location
CanH	A	~	16 pin	06	Blue	(DATA)	OBDII connector, under driver side dash
CanL	A	~	16 pin	14	Pink	(DATA)	OBDII connector, under driver side dash
SWI 1	B	~	20 pin	16	Purple	(DATA)	Behind radio
SWI 2	B		20 pin	06	Brown	(DATA)	Behind radio
SWI Feed	B	~	20 pin	15	Gray	(-)	Behind radio
BT-12	~	~	32 pin	12	White	~	Trunk, right side
BT-13	~	~	32 pin	13	Pink	~	Trunk, right side
BT-14	~	~	32 pin	14	Green	~	Trunk, right side
BT-17	~	~	32 pin	17	Brown	~	Trunk, right side
BT-18	~	~	32 pin	18	Purple	~	Trunk, right side
BT-19	~	~	32 pin	19	Gray	~	Trunk, right side



# INSTALL GUIDE

# NISSAN VERSA HATCHBACK

# BLUETOOTH

# 2012

RETAINS STEERING WHEEL CONTROLS AND ADDS GAUGES



#### PRODUCTS REQUIRED

iDatalink Maestro RR Radio Replacement Interface  
iDatalink Compatible Radio

#### PROGRAMMED FIRMWARE

ADS-RR(SI)-NIS01-DS

#### OPTIONAL ACCESSORIES



Click here for:

[Radar Integration Installation Guide](#)

[Radar Integration Owner's Guide for Kenwood and JVC Radios](#)

# WELCOME

Congratulations on the purchase of your iDatalink Maestro RR Radio replacement solution. You are now a few simple steps away from enjoying your new car radio with enhanced features.

Before starting your installation, please ensure that your iDatalink Maestro module is programmed with the correct firmware for your vehicle and that you carefully review the install guide.

**Please note that Maestro RR will only retain functionalities that were originally available in the vehicle.**

# NEED HELP?

 **1 866 427-2999**

 **[support@idatalink.com](mailto:support@idatalink.com)**

 **[maestro.idatalink.com/support](http://maestro.idatalink.com/support)  
[www.12voltdata.com/forum](http://www.12voltdata.com/forum)**

## TABLE OF CONTENTS

Wiring Diagram	<b>3</b>
Vehicle Wire Reference Chart	<b>4</b>

# WIRING DIAGRAM

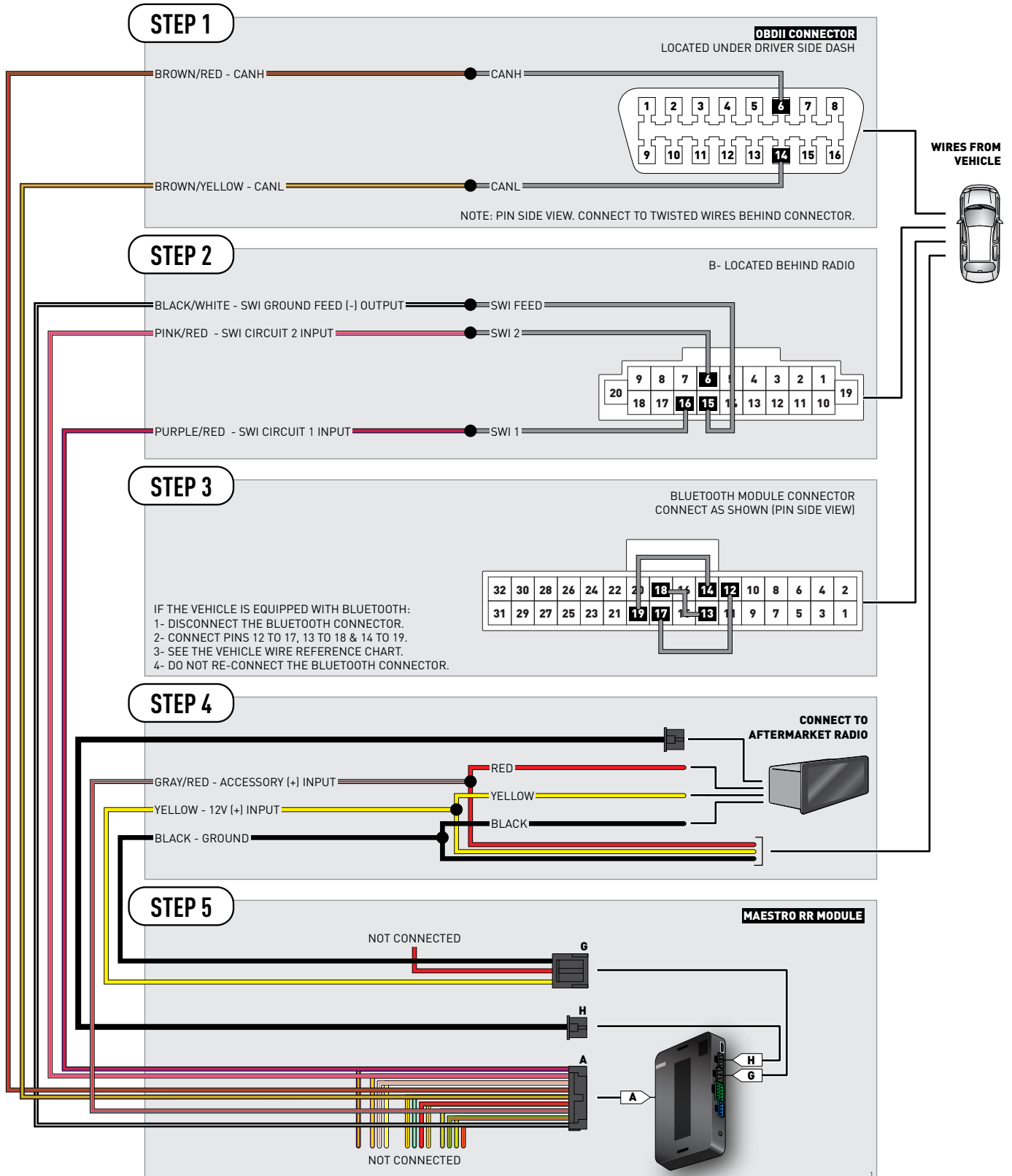

# VEHICLE WIRE REFERENCE CHART

Wire Description	Connector Name	Connector Color	Connector Type	Position	Wire Color	Polarity	Wire Location
CanH	A	~	16 pin	06	Blue	(DATA)	OBDII connector, under driver side dash
CanL	A	~	16 pin	14	Pink	(DATA)	OBDII connector, under driver side dash
SWI 1	B	~	20 pin	16	Pink	(DATA)	Behind radio
SWI 2	B		20 pin	06	Blue	(DATA)	Behind radio
SWI Feed	B	~	20 pin	15	Black	(-)	Behind radio
BT-12	~	~	32 pin	12	White	~	Trunk, right side
BT-13	~	~	32 pin	13	Blue	~	Trunk, right side
BT-14	~	~	32 pin	14	Black	~	Trunk, right side
BT-17	~	~	32 pin	17	Gray	~	Trunk, right side
BT-18	~	~	32 pin	18	Pink	~	Trunk, right side
BT-19	~	~	32 pin	19	Black	~	Trunk, right side



# INSTALL GUIDE

# NISSAN VERSA HATCHBACK

# NAV AND BLUETOOTH

# 2012

RETAINS STEERING WHEEL CONTROLS AND ADDS GAUGES



#### PRODUCTS REQUIRED

iDataLink Maestro RR Radio Replacement Interface  
iDataLink Compatible Radio

#### PROGRAMMED FIRMWARE

ADS-RR(SI)-NIS01-DS

#### OPTIONAL ACCESSORIES



Click here for:

[Radar Integration Installation Guide](#)

[Radar Integration Owner's Guide for Kenwood and JVC Radios](#)

# WELCOME

Congratulations on the purchase of your iDatalink Maestro RR Radio replacement solution. You are now a few simple steps away from enjoying your new car radio with enhanced features.

Before starting your installation, please ensure that your iDatalink Maestro module is programmed with the correct firmware for your vehicle and that you carefully review the install guide.

**Please note that Maestro RR will only retain functionalities that were originally available in the vehicle.**

# NEED HELP?

 **1 866 427-2999**

 **[support@idatalink.com](mailto:support@idatalink.com)**

 **[maestro.idatalink.com/support](http://maestro.idatalink.com/support)  
[www.12voltdata.com/forum](http://www.12voltdata.com/forum)**

## TABLE OF CONTENTS

Wiring Diagram	<b>3</b>
Vehicle Wire Reference Chart	<b>4</b>

# WIRING DIAGRAM

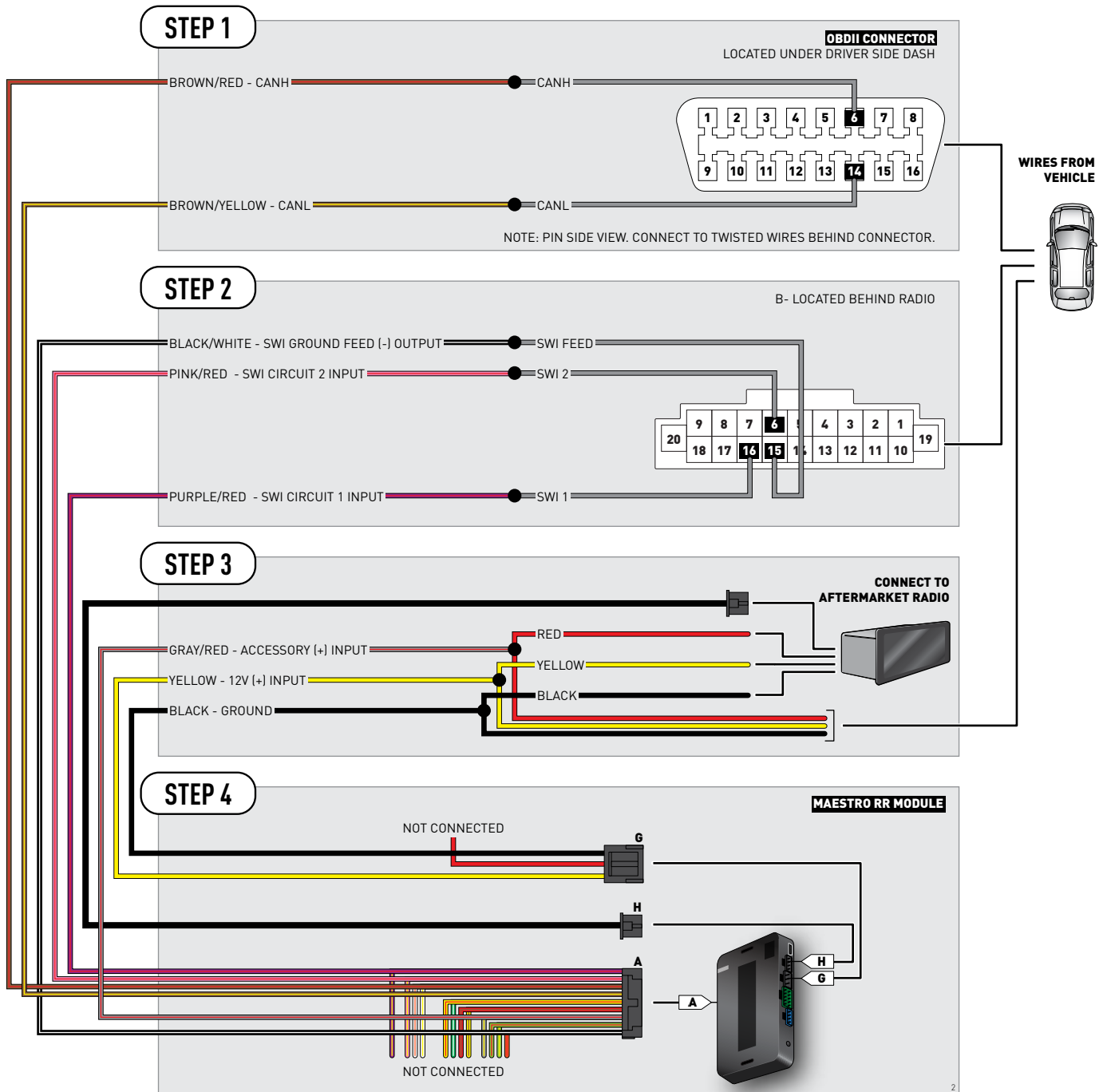



# VEHICLE WIRE REFERENCE CHART

Wire Description	Connector Name	Connector Color	Connector Type	Position	Wire Color	Polarity	Wire Location
CanH	A	~	16 pin	06	Blue	[DATA]	OBDII connector, under driver side dash
CanL	A	~	16 pin	14	Pink	[DATA]	OBDII connector, under driver side dash
SWI 1	B	~	20 pin	16	Pink	[DATA]	Behind radio
SWI 2	B		20 pin	06	Blue	[DATA]	Behind radio
SWI Feed	B	~	20 pin	15	Black	(-)	Behind radio



# INSTALL GUIDE

# NISSAN VERSA

# NAV AND BLUETOOTH

# 2012-2018

RETAINS STEERING WHEEL CONTROLS AND ADDS GAUGES



#### PRODUCTS REQUIRED

iDatalink Maestro RR Radio Replacement Interface  
iDatalink Compatible Radio

#### PROGRAMMED FIRMWARE

ADS-RR(SI)-NIS01-DS

#### OPTIONAL ACCESSORIES



Click here for:

[Radar Integration Installation Guide](#)

[Radar Integration Owner's Guide for Kenwood and JVC Radios](#)

# WELCOME

Congratulations on the purchase of your iDatalink Maestro RR Radio replacement solution. You are now a few simple steps away from enjoying your new car radio with enhanced features.

Before starting your installation, please ensure that your iDatalink Maestro module is programmed with the correct firmware for your vehicle and that you carefully review the install guide.

**Please note that Maestro RR will only retain functionalities that were originally available in the vehicle.**

# NEED HELP?

 **1 866 427-2999**

 [support@idatalink.com](mailto:support@idatalink.com)

 [maestro.idatalink.com/support](http://maestro.idatalink.com/support)  
[www.12voltdata.com/forum](http://www.12voltdata.com/forum)

## TABLE OF CONTENTS

Wiring Diagram	3
Vehicle Wire Reference Chart	4

# WIRING DIAGRAM



# VEHICLE WIRE REFERENCE CHART

Wire Description	Connector Name	Connector Color	Connector Type	Position	Wire Color	Polarity	Wire Location
CanH	A	~	16 pin	06	Blue	[DATA]	OBDII connector, under driver side dash
CanL	A	~	16 pin	14	Pink	[DATA]	OBDII connector, under driver side dash
SWI 1	B	~	20 pin	16	Red	[DATA]	Behind radio
SWI 2	B		20 pin	06	LtGreen	[DATA]	Behind radio
SWI Feed	B	~	20 pin	15	Blue	(-)	Behind radio



# INSTALL GUIDE

# NISSAN VERSA NOTE

# BLUETOOTH

# 2014-2018

RETAINS STEERING WHEEL CONTROLS AND ADDS GAUGES



#### PRODUCTS REQUIRED

iDatalink Maestro RR Radio Replacement Interface  
iDatalink Compatible Radio

#### PROGRAMMED FIRMWARE

ADS-RR(SI)-NIS01-DS

#### OPTIONAL ACCESSORIES



Click here for:

[Radar Integration Installation Guide](#)

[Radar Integration Owner's Guide for Kenwood and JVC Radios](#)

# WELCOME

Congratulations on the purchase of your iDatalink Maestro RR Radio replacement solution. You are now a few simple steps away from enjoying your new car radio with enhanced features.

Before starting your installation, please ensure that your iDatalink Maestro module is programmed with the correct firmware for your vehicle and that you carefully review the install guide.

**Please note that Maestro RR will only retain functionalities that were originally available in the vehicle.**

# NEED HELP?

 **1 866 427-2999**

 [support@idatalink.com](mailto:support@idatalink.com)

 [maestro.idatalink.com/support](http://maestro.idatalink.com/support)  
[www.12voltdata.com/forum](http://www.12voltdata.com/forum)

## TABLE OF CONTENTS

Wiring Diagram	<b>3</b>
Vehicle Wire Reference Chart	<b>4</b>

# WIRING DIAGRAM

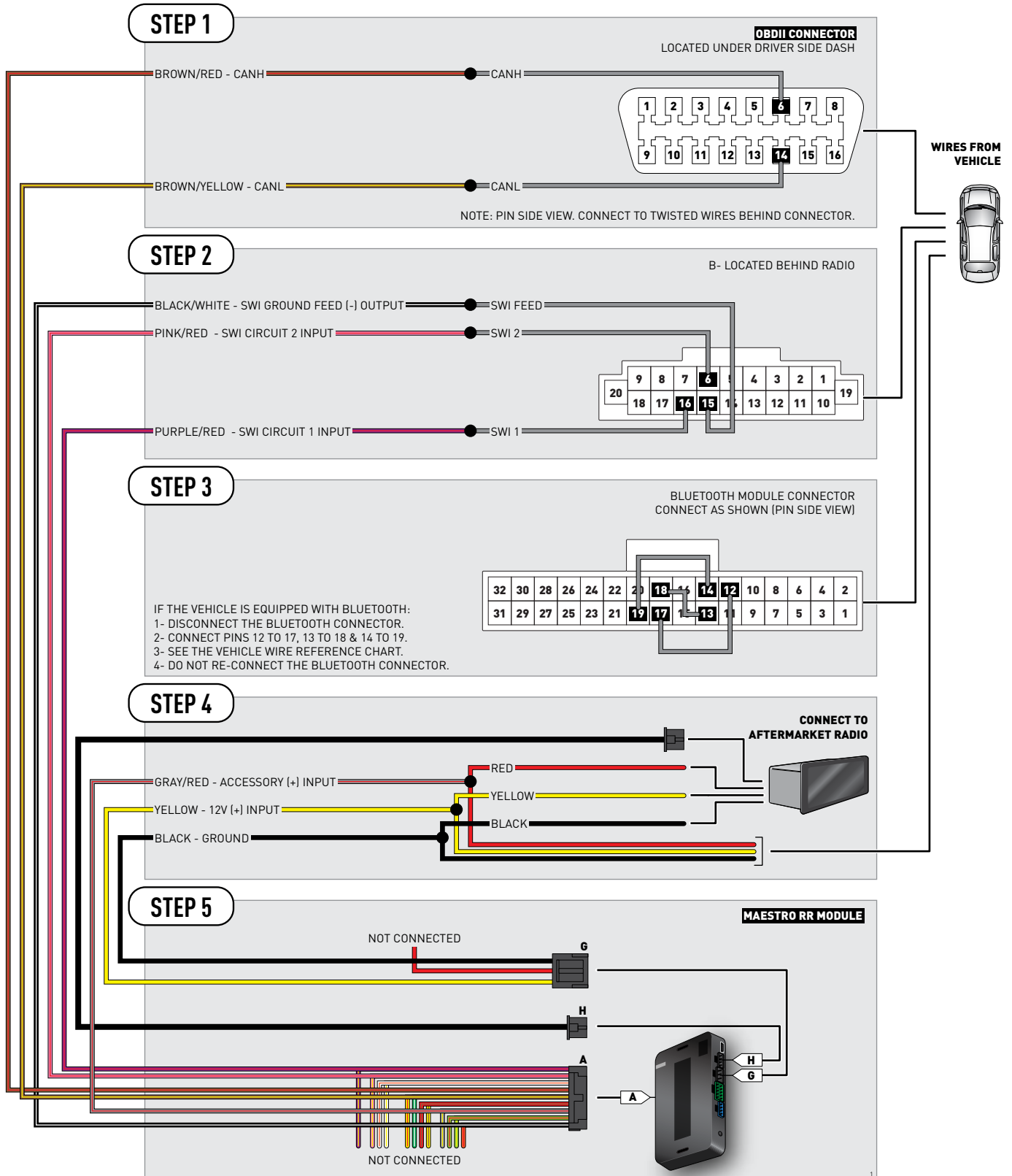



# VEHICLE WIRE REFERENCE CHART

Wire Description	Connector Name	Connector Color	Connector Type	Position	Wire Color	Polarity	Wire Location
CanH	A	~	16 pin	06	Blue	(DATA)	OBDII connector, under driver side dash
CanL	A	~	16 pin	14	Pink	(DATA)	OBDII connector, under driver side dash
SWI 1	B	~	20 pin	16	Purple	(DATA)	Behind radio
SWI 2	B		20 pin	06	Brown	(DATA)	Behind radio
SWI Feed	B	~	20 pin	15	Gray	(-)	Behind radio
BT-12	~	~	32 pin	12	Red	~	Trunk, right side
BT-13	~	~	32 pin	13	Pink	~	Trunk, right side
BT-14	~	~	32 pin	14	Green	~	Trunk, right side
BT-17	~	~	32 pin	17	Brown	~	Trunk, right side
BT-18	~	~	32 pin	18	Purple	~	Trunk, right side
BT-19	~	~	32 pin	19	Gray	~	Trunk, right side



# INSTALL GUIDE

# NISSAN VERSA NOTE

# NAV AND BLUETOOTH

# 2014-2018

RETAINS STEERING WHEEL CONTROLS AND ADDS GAUGES



#### PRODUCTS REQUIRED

iDatalink Maestro RR Radio Replacement Interface  
iDatalink Compatible Radio

#### PROGRAMMED FIRMWARE

ADS-RR(SI)-NIS01-DS

#### OPTIONAL ACCESSORIES



Click here for:

[Radar Integration Installation Guide](#)

[Radar Integration Owner's Guide for Kenwood and JVC Radios](#)

# WELCOME

Congratulations on the purchase of your iDatalink Maestro RR Radio replacement solution. You are now a few simple steps away from enjoying your new car radio with enhanced features.

Before starting your installation, please ensure that your iDatalink Maestro module is programmed with the correct firmware for your vehicle and that you carefully review the install guide.

**Please note that Maestro RR will only retain functionalities that were originally available in the vehicle.**

# NEED HELP?

 **1 866 427-2999**

 **[support@idatalink.com](mailto:support@idatalink.com)**

 **[maestro.idatalink.com/support](http://maestro.idatalink.com/support)  
[www.12voltdata.com/forum](http://www.12voltdata.com/forum)**

## TABLE OF CONTENTS

Wiring Diagram	<b>3</b>
Vehicle Wire Reference Chart	<b>4</b>

# WIRING DIAGRAM



# VEHICLE WIRE REFERENCE CHART

Wire Description	Connector Name	Connector Color	Connector Type	Position	Wire Color	Polarity	Wire Location
CanH	A	~	16 pin	06	Blue	[DATA]	OBDII connector, under driver side dash
CanL	A	~	16 pin	14	Pink	[DATA]	OBDII connector, under driver side dash
SWI 1	B	~	20 pin	16	Purple	[DATA]	Behind radio
SWI 2	B		20 pin	06	LtBlue	[DATA]	Behind radio
SWI Feed	B	~	20 pin	15	Green	(-)	Behind radio



# INSTALL GUIDE NISSAN XTERRA

## 2009-2012

RETAINS STEERING WHEEL CONTROLS AND ADDS GAUGES



### PRODUCTS REQUIRED

iDatalink Maestro RR Radio Replacement Interface  
iDatalink Compatible Radio

### PROGRAMMED FIRMWARE

ADS-RR(SI)-NIS01-DS

### OPTIONAL ACCESSORIES



Click here for:

[Radar Integration Installation Guide](#)

[Radar Integration Owner's Guide for Kenwood and JVC Radios](#)

# WELCOME

Congratulations on the purchase of your iDatalink Maestro RR Radio replacement solution. You are now a few simple steps away from enjoying your new car radio with enhanced features.

Before starting your installation, please ensure that your iDatalink Maestro module is programmed with the correct firmware for your vehicle and that you carefully review the install guide.

**Please note that Maestro RR will only retain functionalities that were originally available in the vehicle.**

# NEED HELP?

 **1 866 427-2999**

 [support@idatalink.com](mailto:support@idatalink.com)

 [maestro.idatalink.com/support](http://maestro.idatalink.com/support)  
[www.12voltdata.com/forum](http://www.12voltdata.com/forum)

## TABLE OF CONTENTS

Wiring Diagram	<b>3</b>
Vehicle Wire Reference Chart	<b>4</b>

# WIRING DIAGRAM

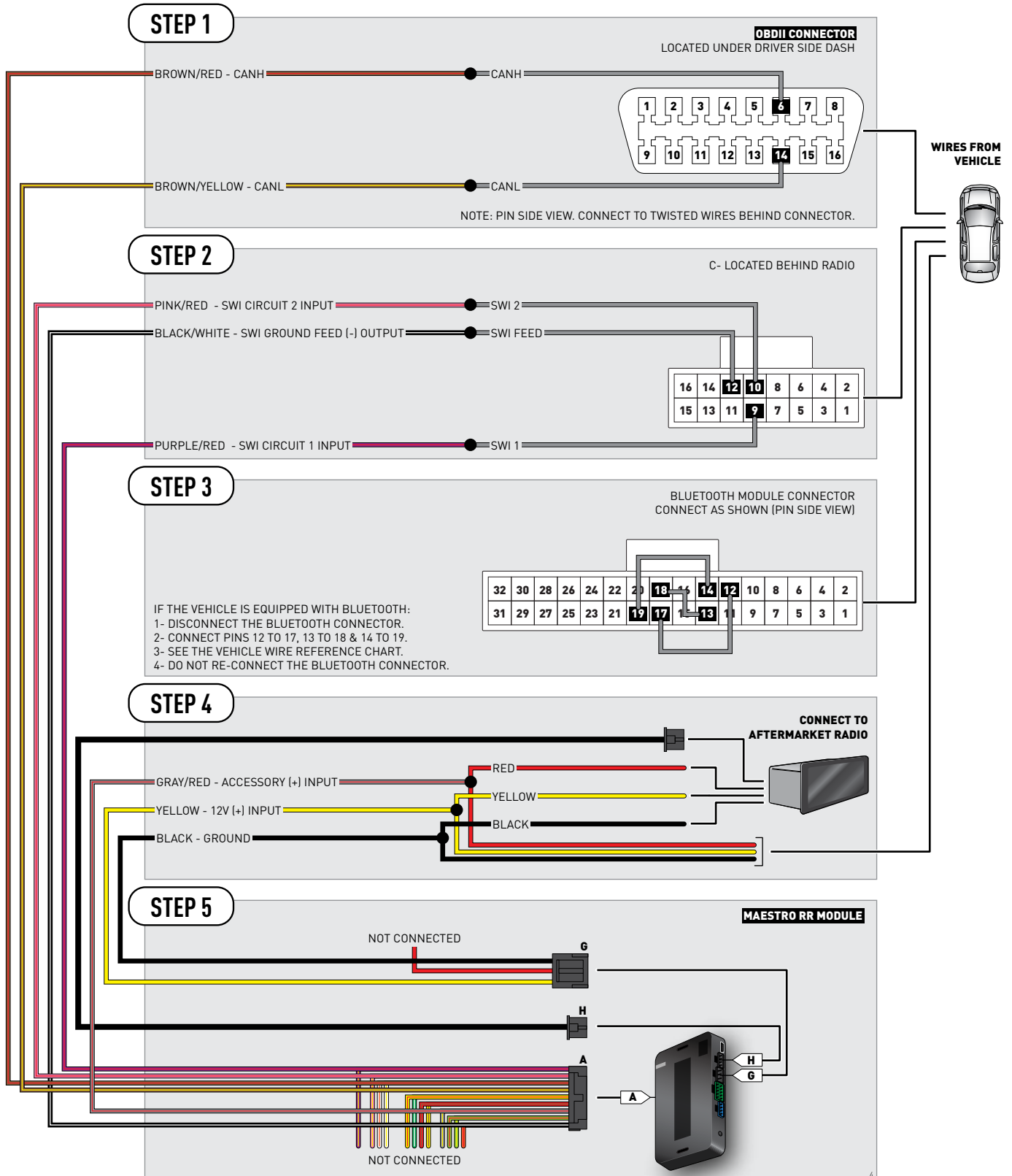



# VEHICLE WIRE REFERENCE CHART

Wire Description	Connector Name	Connector Color	Connector Type	Position	Wire Color	Polarity	Wire Location
CanH	A	~	16 pin	06	Blue	(DATA)	OBDII connector, under driver side dash
CanL	A	~	16 pin	14	Pink	(DATA)	OBDII connector, under driver side dash
SWI 1	C	~	16 pin	09	LtGreen	(DATA)	Behind radio
SWI 2	C	~	16 pin	10	Purple	(DATA)	Behind radio
SWI Feed	C	~	16 pin	12	Orange	(-)	Behind radio
BT-12	~	~	32 pin	12	Brown	~	Under passenger seat
BT-13	~	~	32 pin	13	Blue	~	Under passenger seat
BT-14	~	~	32 pin	14	Green	~	Under passenger seat
BT-17	~	~	32 pin	17	Purple	~	Under passenger seat
BT-18	~	~	32 pin	18	Green	~	Under passenger seat
BT-19	~	~	32 pin	19	Orange	~	Under passenger seat



# INSTALL GUIDE NISSAN XTERRA

## 2015

RETAINS STEERING WHEEL CONTROLS AND ADDS GAUGES



#### PRODUCTS REQUIRED

iDatalink Maestro RR Radio Replacement Interface  
iDatalink Compatible Radio

#### PROGRAMMED FIRMWARE

ADS-RR(SI)-NIS01-DS

#### OPTIONAL ACCESSORIES



Click here for:

[Radar Integration Installation Guide](#)

[Radar Integration Owner's Guide for Kenwood and JVC Radios](#)

# WELCOME

Congratulations on the purchase of your iDatalink Maestro RR Radio replacement solution. You are now a few simple steps away from enjoying your new car radio with enhanced features.

Before starting your installation, please ensure that your iDatalink Maestro module is programmed with the correct firmware for your vehicle and that you carefully review the install guide.

**Please note that Maestro RR will only retain functionalities that were originally available in the vehicle.**

# NEED HELP?

 **1 866 427-2999**

 [support@idatalink.com](mailto:support@idatalink.com)

 [maestro.idatalink.com/support](http://maestro.idatalink.com/support)  
[www.12voltdata.com/forum](http://www.12voltdata.com/forum)

## TABLE OF CONTENTS

Wiring Diagram	<b>3</b>
Vehicle Wire Reference Chart	<b>4</b>

# WIRING DIAGRAM



# VEHICLE WIRE REFERENCE CHART

Wire Description	Connector Name	Connector Color	Connector Type	Position	Wire Color	Polarity	Wire Location
CanH	A	~	16 pin	06	Blue	[DATA]	OBDII connector, under driver side dash
CanL	A	~	16 pin	14	Pink	[DATA]	OBDII connector, under driver side dash
SWI 1	B	~	20 pin	16	White	[DATA]	Behind radio
SWI 2	B	~	20 pin	06	Brown	[DATA]	Behind radio
SWI Feed	B	~	20 pin	15	Green	(-)	Behind radio



# INSTALL GUIDE

# NISSAN XTERRA

# BLUETOOTH

# 2013-2014

RETAINS STEERING WHEEL CONTROLS AND ADDS GAUGES



#### PRODUCTS REQUIRED

iDatalink Maestro RR Radio Replacement Interface  
iDatalink Compatible Radio

#### PROGRAMMED FIRMWARE

ADS-RR(SI)-NIS01-DS

#### OPTIONAL ACCESSORIES



Click here for:

[Radar Integration Installation Guide](#)

[Radar Integration Owner's Guide for Kenwood and JVC Radios](#)

# WELCOME

Congratulations on the purchase of your iDatalink Maestro RR Radio replacement solution. You are now a few simple steps away from enjoying your new car radio with enhanced features.

Before starting your installation, please ensure that your iDatalink Maestro module is programmed with the correct firmware for your vehicle and that you carefully review the install guide.

**Please note that Maestro RR will only retain functionalities that were originally available in the vehicle.**

# NEED HELP?

 **1 866 427-2999**

 [support@idatalink.com](mailto:support@idatalink.com)

 [maestro.idatalink.com/support](http://maestro.idatalink.com/support)  
[www.12voltdata.com/forum](http://www.12voltdata.com/forum)

## TABLE OF CONTENTS

Wiring Diagram	<b>3</b>
Vehicle Wire Reference Chart	<b>4</b>

# WIRING DIAGRAM

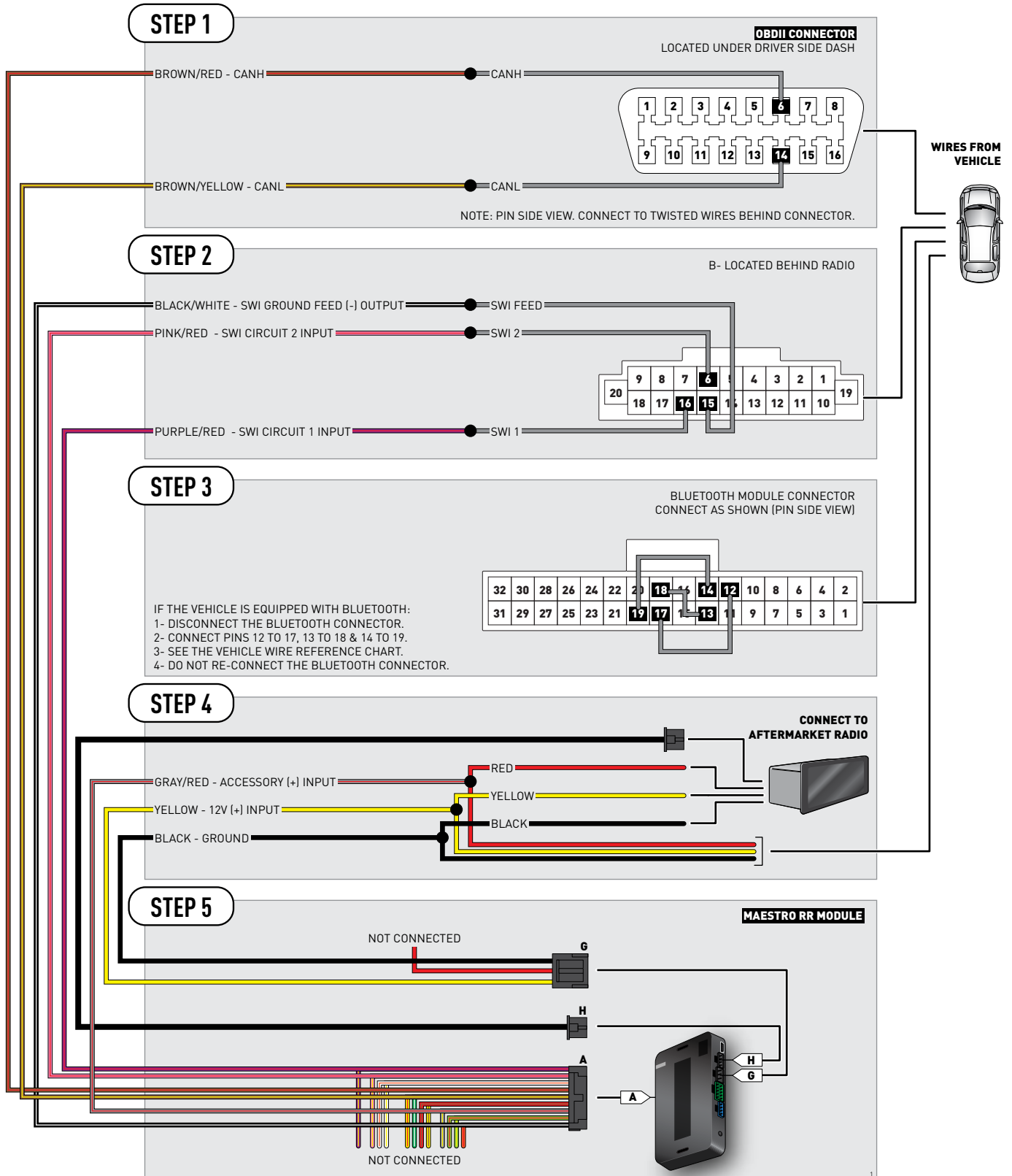



# VEHICLE WIRE REFERENCE CHART

Wire Description	Connector Name	Connector Color	Connector Type	Position	Wire Color	Polarity	Wire Location
CanH	A	~	16 pin	06	Blue	(DATA)	OBDII connector, under driver side dash
CanL	A	~	16 pin	14	Pink	(DATA)	OBDII connector, under driver side dash
SWI 1	B	~	20 pin	16	Orange or Tan	(DATA)	Behind radio
SWI 2	B	~	20 pin	06	Purple	(DATA)	Behind radio
SWI Feed	B	~	20 pin	15	Green	(-)	Behind radio
BT-12	~	~	32 pin	12	Brown	~	Under passenger seat
BT-13	~	~	32 pin	13	Blue	~	Under passenger seat
BT-14	~	~	32 pin	14	Green	~	Under passenger seat
BT-17	~	~	32 pin	17	Purple	~	Under passenger seat
BT-18	~	~	32 pin	18	LtGreen	~	Under passenger seat
BT-19	~	~	32 pin	19	Orange or Tan	~	Under passenger seat



# INSTALL GUIDE

# NISSAN XTERRA

# NAV AND BLUETOOTH

# 2013-2014

RETAINS STEERING WHEEL CONTROLS AND ADDS GAUGES



#### PRODUCTS REQUIRED

iDatalink Maestro RR Radio Replacement Interface  
iDatalink Compatible Radio

#### PROGRAMMED FIRMWARE

ADS-RR(SI)-NIS01-DS

#### OPTIONAL ACCESSORIES



Click here for:

[Radar Integration Installation Guide](#)

[Radar Integration Owner's Guide for Kenwood and JVC Radios](#)

# WELCOME

Congratulations on the purchase of your iDatalink Maestro RR Radio replacement solution. You are now a few simple steps away from enjoying your new car radio with enhanced features.

Before starting your installation, please ensure that your iDatalink Maestro module is programmed with the correct firmware for your vehicle and that you carefully review the install guide.

**Please note that Maestro RR will only retain functionalities that were originally available in the vehicle.**

# NEED HELP?

 **1 866 427-2999**

 [support@idatalink.com](mailto:support@idatalink.com)

 [maestro.idatalink.com/support](http://maestro.idatalink.com/support)  
[www.12voltdata.com/forum](http://www.12voltdata.com/forum)

## TABLE OF CONTENTS

Wiring Diagram	<b>3</b>
Vehicle Wire Reference Chart	<b>4</b>

# WIRING DIAGRAM

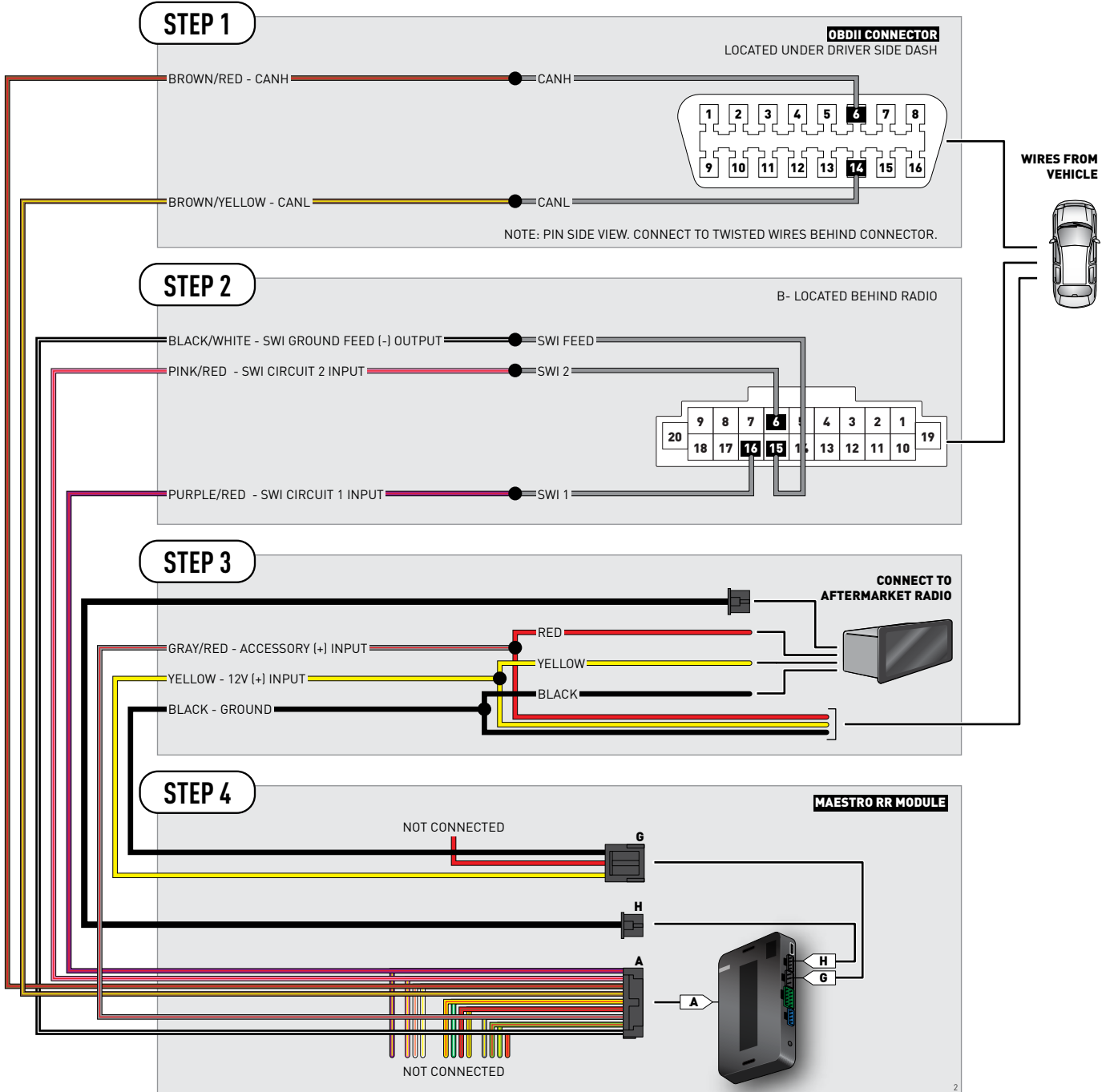

# VEHICLE WIRE REFERENCE CHART

Wire Description	Connector Name	Connector Color	Connector Type	Position	Wire Color	Polarity	Wire Location
CanH	A	~	16 pin	06	Blue	[DATA]	OBDII connector, under driver side dash
CanL	A	~	16 pin	14	Pink	[DATA]	OBDII connector, under driver side dash
SWI 1	B	~	20 pin	16	White	[DATA]	Behind radio
SWI 2	B	~	20 pin	06	Brown	[DATA]	Behind radio
SWI Feed	B	~	20 pin	15	Green	(-)	Behind radio