



HOW TO USE THIS INSTALL GUIDE

- 1** Open the Bookmarks menu and find your vehicle OR scroll down until you find the install guide for your vehicle.
- 2** Print only the pages for your vehicle using the advanced options in the Print menu.
- 3** Install your Maestro RR according to the guide for your vehicle.

WARNING

Pressing the printer icon or “quick printing” this document will print all of the guides in this compilation.



INSTALL GUIDE BUICK ENCLAVE 2008-2017

RETAINS STEERING WHEEL CONTROLS, ONSTAR, BLUETOOTH, XM SATELLITE AND MORE!



PRODUCTS REQUIRED

iDatalink Maestro RR Radio Replacement Interface
iDatalink Maestro GM5+ Installation Harness

OPTIONAL ACCESSORIES

None

PROGRAMMED FIRMWARE

ADS-RR(SR)-GMS05-DS

NOTICE: Automotive Data Solutions Inc. (ADS) recommends having this installation performed by a certified technician. Logos and trademarks used here in are the properties of their respective owners.

WELCOME

Congratulations on the purchase of your iDatalink Maestro RR Radio replacement solution. You are now a few simple steps away from enjoying your new car radio with enhanced features.

Before starting your installation, please ensure that your iDatalink Maestro module is programmed with the correct firmware for your vehicle and that you carefully review the install guide.

Please note that Maestro RR will only retain functionalities that were originally available in the vehicle.

NEED HELP?

 **1 866 427-2999**

 **support@idatalink.com**

 **maestro.idatalink.com/support
www.12voltdata.com/forum**

TABLE OF CONTENTS

Before Installing	3
Installation Instructions	4
Wiring Diagram with an Amplifier	5
Wiring Diagram without an Amplifier	6
Vehicle Wire Reference Chart	7
Radio Wire Reference Chart	8

BEFORE INSTALLING

STEP 1

DETERMINE IF YOUR VEHICLE IS EQUIPPED WITH A FACTORY AMPLIFIER:

METHOD 1: Look for the following logos in the vehicle. They are usually on the speaker covers or on the radio unit. If you find any of the following logos Bose, Pioneer or Monsoon, you have a factory amplifier.



METHOD 2: Look for the following sticker in the glove box. This sticker will indicate all the Regular Production Option (RPO) codes. If you find any of the following codes UQA, UQS or UQG, you have a factory amplifier.

SERVICE PARTS IDENTIFICATION												DO NOT REMOVE	
2GCEK19N031344764						143 5 FXWH2Q			CKI5753				
AGI	AG2	AJ1	AL0	AM7	AN3	AU0	AU3	A31	B30	B4U			
B58	B81	B82	CJ3	C49	C7H	DF5	DK7	DL3	DT4	D07			
EVA	E63	FF8	FF9	GT5	G80	JC4	KC4	KNP	KUP	K34			
K47	K68	LQ9	M32	NCI	NEI	NP3	NP5	QCC	P30	QSS			
R4Y	R9U	R9Z	SAF	SLM	TRB	UC6	UK3	UQA	U2K	UFI			
UF3	UK3	VR4	VTV	VXS	V73	XSS	X88	YD6	YE9				
YSS	ZGC	ZYI	Z60	Z82	ISS	ISZ	4IU	6YT	691	692			
7YT													
BC/CC		U	8555			692							

STEP 2

IF YOUR VEHICLE IS EQUIPPED WITH A FACTORY AMPLIFIER:

Follow the installation instructions and complete the installation as shown in the wiring diagram **with an amplifier** and read the "AMPLIFIER ONLY" note to determine if you should use rca's or level matching circuits.

IF YOUR VEHICLE NOT IS EQUIPPED WITH A FACTORY AMPLIFIER:

Follow the installation instructions and complete the installation as shown in the wiring diagram **without an amplifier**.

INSTALLATION INSTRUCTIONS

STEP 1

- Unbox the aftermarket radio and locate its main harness.
- Connect the wires shown on the next page from aftermarket radio main harness to the GM5+ T-harness and match the wire functions.

STEP 2

- Connect the factory harness to the GM5+ T-harness.

STEP 3

- Access the OBDII connector located under the driver side dashboard.
- Connect the BROWN /RED wire of the GM5+ T-harness to the wire located at pin 6 of the OBDII connector. (See the vehicle wire chart reference for wire colors)
- Connect the BROWN /YELLOW wire of the GM5+ T-harness to the wire located at pin 14 of the OBDII connector. (See the vehicle wire chart reference for wire colors)

STEP 4

- Plug the aftermarket radio harnesses into the aftermarket radio.
- Plug the Data cable to the data port of the aftermarket radio.
- Insert the Audio cable into the iDataLink 3.5 mm audio jack of the aftermarket radio.

STEP 5

- Connect all the harnesses to the Maestro RR module then proceed to module setup.

The module is now ready to be used.

Insert the aftermarket radio in the dashboard housing and test all the functionalities.

Reassemble the dashboard carefully.

AMPLIFIER ONLY

DETERMINE IF YOU SHOULD USE RCA'S OR LEVEL MATCHING CIRCUITS

- If your vehicle is equipped with a factory amplifier you can connect the RCA wiring to the low level outputs of your aftermarket radio, or connect the level matching circuits to the speaker outputs of the aftermarket radio.
- If your aftermarket radio does not have low level outputs, has only a single RCA output, or the RCA output level is 2 volts or less then it is recommended to connect the level matching circuit to the speaker outputs. If the volume does not go loud enough using the RCA connections, the level matching circuits can be used.
- The internal amplifier in some radios is not compatible with the level matching circuit. In these cases, there will be floor noise (hissing or buzzing at low levels) when the level matching circuit is connected. Change to the RCA connections to eliminate this noise.

TROUBLESHOOTING TIPS:

- To reset the module back its factory settings, turn the key to the OFF position then disconnect all connectors from the module. Press and hold the module's programming button and connect all the connectors back to the module. Wait, the module's LED will flash RED rapidly (this may take up to 10 seconds). Release the programming button. Wait, the LED will turn solid GREEN for 2 seconds.
- For technical assistance call 1-866-427-2999 or e-mail "support@idatalink.com". Visit us at "maestro.idatalink.com/support" and "www.12voltdata.com/forum/"

WIRING DIAGRAM *with an Amplifier*



WIRING DIAGRAM *without an Amplifier*

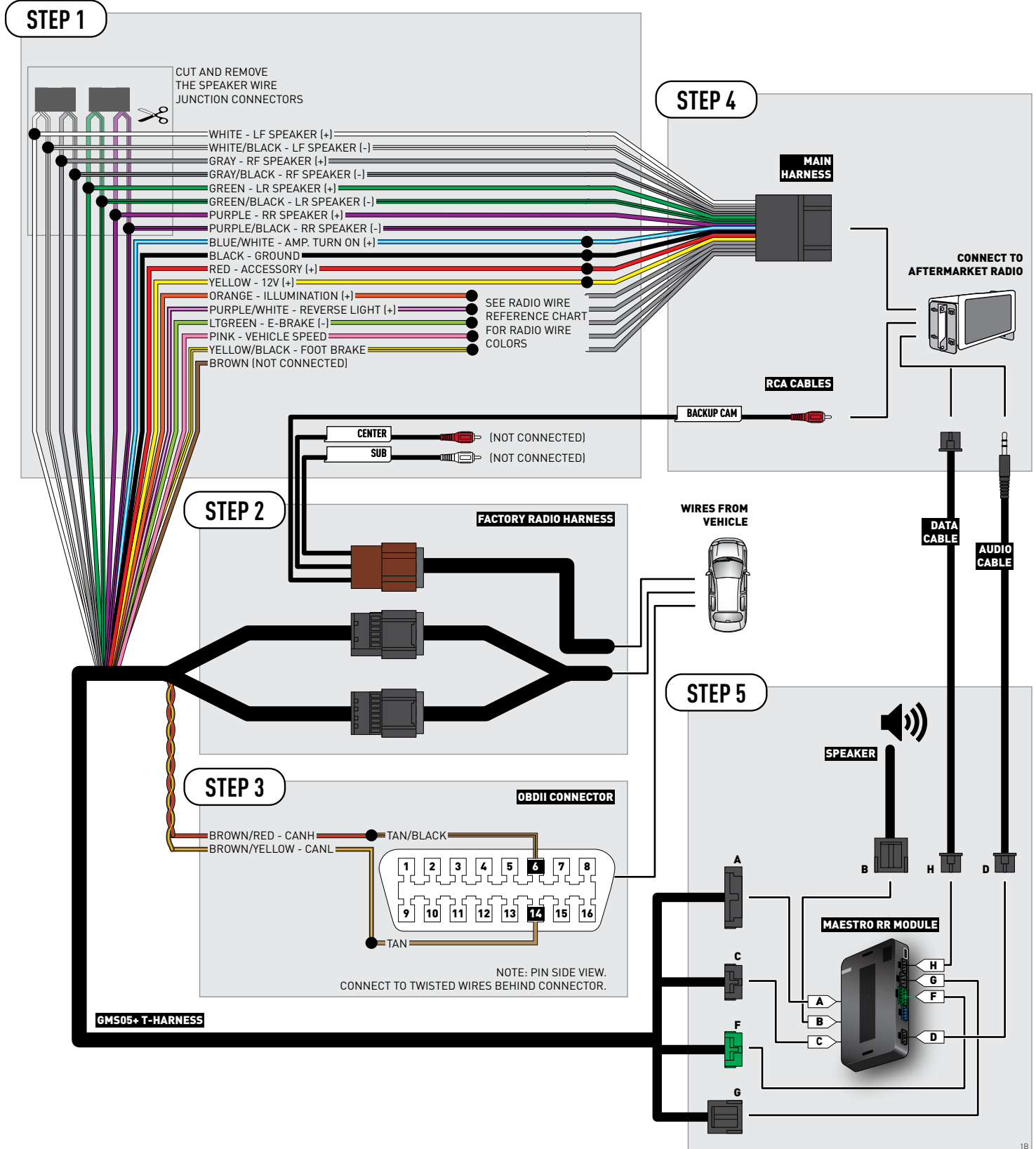

VEHICLE WIRE REFERENCE CHART

Wire Description	Connector Name	Connector Color	Connector Type	Position	Wire Color	Polarity	Wire Location
CanH	OBDII	~	16 pin	06	Tan/Black	(Data)	OBDII connector, under driver side dash
CanL	OBDII	~	16 pin	14	Tan	(Data)	OBDII connector, under driver side dash

RADIO WIRE REFERENCE CHART

Wire Description	Polarity	Wire Color on Maestro T-Harness	Wire Color on Alpine cable	Wire Color on Kenwood cable	Wire Color on Pioneer cable
Illumination	(+)	Orange	N/A	Orange/White	Orange/White
Reverse Light	(+)	Purple/White	Orange/White	Purple/White	Purple/White
E-Brake	(-)	Lt Green	Yellow/Blue	Lt Green	Lt Green
Foot Brake	(+)	Yellow/Black	Yellow/Black	N/A	N/A
VSS (vehicle speed sensor)	(DATA)	Pink	Green/White	N/A	Pink



INSTALL GUIDE BUICK LUCERNE 2006-2011

RETAINS STEERING WHEEL CONTROLS, ONSTAR, BLUETOOTH, XM SATELLITE AND MORE!



PRODUCTS REQUIRED

iDatalink Maestro RR Radio Replacement Interface
iDatalink Maestro GM5+ Installation Harness

OPTIONAL ACCESSORIES

None

PROGRAMMED FIRMWARE

ADS-RR(SR)-GMS05-DS

NOTICE: Automotive Data Solutions Inc. (ADS) recommends having this installation performed by a certified technician. Logos and trademarks used here in are the properties of their respective owners.

WELCOME

Congratulations on the purchase of your iDatalink Maestro RR Radio replacement solution. You are now a few simple steps away from enjoying your new car radio with enhanced features.

Before starting your installation, please ensure that your iDatalink Maestro module is programmed with the correct firmware for your vehicle and that you carefully review the install guide.

Please note that Maestro RR will only retain functionalities that were originally available in the vehicle.

NEED HELP?

 **1 866 427-2999**

 support@idatalink.com

 maestro.idatalink.com/support
www.12voltdata.com/forum

TABLE OF CONTENTS

Before Installing	3
Installation Instructions	4
Wiring Diagram with an Amplifier	5
Wiring Diagram without an Amplifier	6
Vehicle Wire Reference Chart	7
Radio Wire Reference Chart	8

BEFORE INSTALLING

STEP 1

DETERMINE IF YOUR VEHICLE IS EQUIPPED WITH A FACTORY AMPLIFIER:

METHOD 1: Look for the following logos in the vehicle. They are usually on the speaker covers or on the radio unit. If you find any of the following logos Bose, Pioneer or Monsoon, you have a factory amplifier.



METHOD 2: Look for the following sticker in the glove box. This sticker will indicate all the Regular Production Option (RPO) codes. If you find any of the following codes UQA, UQS or UQG, you have a factory amplifier.

SERVICE PARTS IDENTIFICATION												DO NOT REMOVE	
2GCEK19N031344764						143 5 FXWH2Q			CKI5753				
AGI	AG2	AJ1	AL0	AM7	AN3	AU0	AU3	A31	B30	B4U			
B58	B81	B82	CJ3	C49	C7H	DF5	DK7	DL3	DT4	D07			
EVA	E63	FF8	FF9	GT5	G80	JC4	KC4	KNP	KUP	K34			
K47	K68	LQ9	M32	NCI	NEI	NP3	NP5	QCC	P30	QSS			
R4Y	R9U	R9Z	SAF	SLM	TRB	UC6	UK3	UQA	U2K	UFI			
UF3	UK3	VR4	VTV	VXS	V73	XSS	X88	YD6	YD6	YE9			
YSS	ZGC	ZYI	Z60	Z82	ISS	ISZ	4IU	6YT	691	692			
7YT													
BC/CC	U	8555				692							

STEP 2

IF YOUR VEHICLE IS EQUIPPED WITH A FACTORY AMPLIFIER:

Follow the installation instructions and complete the installation as shown in the wiring diagram **with an amplifier** and read the "AMPLIFIER ONLY" note to determine if you should use rca's or level matching circuits.

IF YOUR VEHICLE NOT IS EQUIPPED WITH A FACTORY AMPLIFIER:

Follow the installation instructions and complete the installation as shown in the wiring diagram **without an amplifier**.

INSTALLATION INSTRUCTIONS

STEP 1

- Unbox the aftermarket radio and locate its main harness.
- Connect the wires shown on the next page from aftermarket radio main harness to the GM5+ T-harness and match the wire functions.

STEP 2

- Connect the factory harness to the GM5+ T-harness.

STEP 3

- Access the OBDII connector located under the driver side dashboard.
- Connect the BROWN /RED wire of the GM5+ T-harness to the wire located at pin 6 of the OBDII connector. (See the vehicle wire chart reference for wire colors)
- Connect the BROWN /YELLOW wire of the GM5+ T-harness to the wire located at pin 14 of the OBDII connector. (See the vehicle wire chart reference for wire colors)

STEP 4

- Plug the aftermarket radio harnesses into the aftermarket radio.
- Plug the Data cable to the data port of the aftermarket radio.
- Insert the Audio cable into the iDatalink 3.5 mm audio jack of the aftermarket radio.

STEP 5

- Connect all the harnesses to the Maestro RR module then proceed to module setup.

The module is now ready to be used.

Insert the aftermarket radio in the dashboard housing and test all the functionalities.

Reassemble the dashboard carefully.

AMPLIFIER ONLY

DETERMINE IF YOU SHOULD USE RCA'S OR LEVEL MATCHING CIRCUITS

- If your vehicle is equipped with a factory amplifier you can connect the RCA wiring to the low level outputs of your aftermarket radio, or connect the level matching circuits to the speaker outputs of the aftermarket radio.
- If your aftermarket radio does not have low level outputs, has only a single RCA output, or the RCA output level is 2 volts or less then it is recommended to connect the level matching circuit to the speaker outputs. If the volume does not go loud enough using the RCA connections, the level matching circuits can be used.
- The internal amplifier in some radios is not compatible with the level matching circuit. In these cases, there will be floor noise (hissing or buzzing at low levels) when the level matching circuit is connected. Change to the RCA connections to eliminate this noise.

TROUBLESHOOTING TIPS:

- To reset the module back its factory settings, turn the key to the OFF position then disconnect all connectors from the module. Press and hold the module's programming button and connect all the connectors back to the module. Wait, the module's LED will flash RED rapidly (this may take up to 10 seconds). Release the programming button. Wait, the LED will turn solid GREEN for 2 seconds.
- For technical assistance call 1-866-427-2999 or e-mail "support@idatalink.com". Visit us at "maestro.idatalink.com/support" and "www.12voltdata.com/forum/"

WIRING DIAGRAM *with an Amplifier*



WIRING DIAGRAM *without an Amplifier*



VEHICLE WIRE REFERENCE CHART

Wire Description	Connector Name	Connector Color	Connector Type	Position	Wire Color	Polarity	Wire Location
CanH	OBDII	~	16 pin	06	Tan/Black	(Data)	OBDII connector, under driver side dash
CanL	OBDII	~	16 pin	14	Tan	(Data)	OBDII connector, under driver side dash

RADIO WIRE REFERENCE CHART

Wire Description	Polarity	Wire Color on Maestro T-Harness	Wire Color on Alpine cable	Wire Color on Kenwood cable	Wire Color on Pioneer cable
Illumination	(+)	Orange	N/A	Orange/White	Orange/White
Reverse Light	(+)	Purple/White	Orange/White	Purple/White	Purple/White
E-Brake	(-)	Lt Green	Yellow/Blue	Lt Green	Lt Green
Foot Brake	(+)	Yellow/Black	Yellow/Black	N/A	N/A
VSS (vehicle speed sensor)	(DATA)	Pink	Green/White	N/A	Pink



INSTALL GUIDE CADILLAC DTS 2006-2011

RETAINS STEERING WHEEL CONTROLS, ONSTAR, BLUETOOTH, XM SATELLITE AND MORE!



PRODUCTS REQUIRED

iDatalink Maestro RR Radio Replacement Interface
iDatalink Maestro GM5+ Installation Harness

OPTIONAL ACCESSORIES

None

PROGRAMMED FIRMWARE

ADS-RR(SR)-GMS05-DS

NOTICE: Automotive Data Solutions Inc. (ADS) recommends having this installation performed by a certified technician. Logos and trademarks used here in are the properties of their respective owners.

WELCOME

Congratulations on the purchase of your iDatalink Maestro RR Radio replacement solution. You are now a few simple steps away from enjoying your new car radio with enhanced features.

Before starting your installation, please ensure that your iDatalink Maestro module is programmed with the correct firmware for your vehicle and that you carefully review the install guide.

Please note that Maestro RR will only retain functionalities that were originally available in the vehicle.

NEED HELP?

 **1 866 427-2999**

 support@idatalink.com

 maestro.idatalink.com/support
www.12voltdata.com/forum

TABLE OF CONTENTS

Before Installing	3
Installation Instructions	4
Wiring Diagram with an Amplifier	5
Wiring Diagram without an Amplifier	6
Vehicle Wire Reference Chart	7
Radio Wire Reference Chart	8

BEFORE INSTALLING

STEP 1

DETERMINE IF YOUR VEHICLE IS EQUIPPED WITH A FACTORY AMPLIFIER:

METHOD 1: Look for the following logos in the vehicle. They are usually on the speaker covers or on the radio unit. If you find any of the following logos Bose, Pioneer or Monsoon, you have a factory amplifier.



METHOD 2: Look for the following sticker in the glove box. This sticker will indicate all the Regular Production Option (RPO) codes. If you find any of the following codes UQA, UQS or UQG, you have a factory amplifier.

SERVICE PARTS IDENTIFICATION										DO NOT REMOVE		
2GCEK19N031344764				143 5 FXWH2Q			CKI5753					
AGI	AG2	AJ1	AL0	AM7	AN3	AU0	AU3	A31	B30	B4U		
B58	B81	B82	CJ3	C49	C7H	DF5	DK7	DL3	DT4	D07		
EVA	E63	FF8	FF9	GT5	G80	JC4	KC4	KNP	KUP	K34		
K47	K68	LQ9	M32	NCI	NEI	NP3	NP5	QCC	P30	QSS		
R4Y	R9U	R9Z	SAF	SLM	TRB	UC6	UK3	UQA	U2K	UFI		
UF3	UK3	VR4	VTV	VXS	V73	XSS	X88	YD6	YE9	YE9		
YSS	ZGC	ZYI	Z60	Z82	ISS	ISZ	4IU	6YT	691	692		
7YT												
BC/CC	U	8555				692						

STEP 2

IF YOUR VEHICLE IS EQUIPPED WITH A FACTORY AMPLIFIER:

Follow the installation instructions and complete the installation as shown in the wiring diagram **with an amplifier** and read the "AMPLIFIER ONLY" note to determine if you should use rca's or level matching circuits.

IF YOUR VEHICLE NOT IS EQUIPPED WITH A FACTORY AMPLIFIER:

Follow the installation instructions and complete the installation as shown in the wiring diagram **without an amplifier**.

INSTALLATION INSTRUCTIONS

STEP 1

- Unbox the aftermarket radio and locate its main harness.
- Connect the wires shown on the next page from aftermarket radio main harness to the GM5+ T-harness and match the wire functions.

STEP 2

- Connect the factory harness to the GM5+ T-harness.

STEP 3

- Access the OBDII connector located under the driver side dashboard.
- Connect the BROWN /RED wire of the GM5+ T-harness to the wire located at pin 6 of the OBDII connector. (See the vehicle wire chart reference for wire colors)
- Connect the BROWN /YELLOW wire of the GM5+ T-harness to the wire located at pin 14 of the OBDII connector. (See the vehicle wire chart reference for wire colors)

STEP 4

- Plug the aftermarket radio harnesses into the aftermarket radio.
- Plug the Data cable to the data port of the aftermarket radio.
- Insert the Audio cable into the iDatalink 3.5 mm audio jack of the aftermarket radio.

STEP 5

- Connect all the harnesses to the Maestro RR module then proceed to module setup.

The module is now ready to be used.

Insert the aftermarket radio in the dashboard housing and test all the functionalities.

Reassemble the dashboard carefully.

AMPLIFIER ONLY

DETERMINE IF YOU SHOULD USE RCA'S OR LEVEL MATCHING CIRCUITS

- If your vehicle is equipped with a factory amplifier you can connect the RCA wiring to the low level outputs of your aftermarket radio, or connect the level matching circuits to the speaker outputs of the aftermarket radio.
- If your aftermarket radio does not have low level outputs, has only a single RCA output, or the RCA output level is 2 volts or less then it is recommended to connect the level matching circuit to the speaker outputs. If the volume does not go loud enough using the RCA connections, the level matching circuits can be used.
- The internal amplifier in some radios is not compatible with the level matching circuit. In these cases, there will be floor noise (hissing or buzzing at low levels) when the level matching circuit is connected. Change to the RCA connections to eliminate this noise.

TROUBLESHOOTING TIPS:

- To reset the module back its factory settings, turn the key to the OFF position then disconnect all connectors from the module. Press and hold the module's programming button and connect all the connectors back to the module. Wait, the module's LED will flash RED rapidly (this may take up to 10 seconds). Release the programming button. Wait, the LED will turn solid GREEN for 2 seconds.
- For technical assistance call 1-866-427-2999 or e-mail "support@idatalink.com". Visit us at "maestro.idatalink.com/support" and "www.12voltdata.com/forum/"

WIRING DIAGRAM *with an Amplifier*



WIRING DIAGRAM *without an Amplifier*

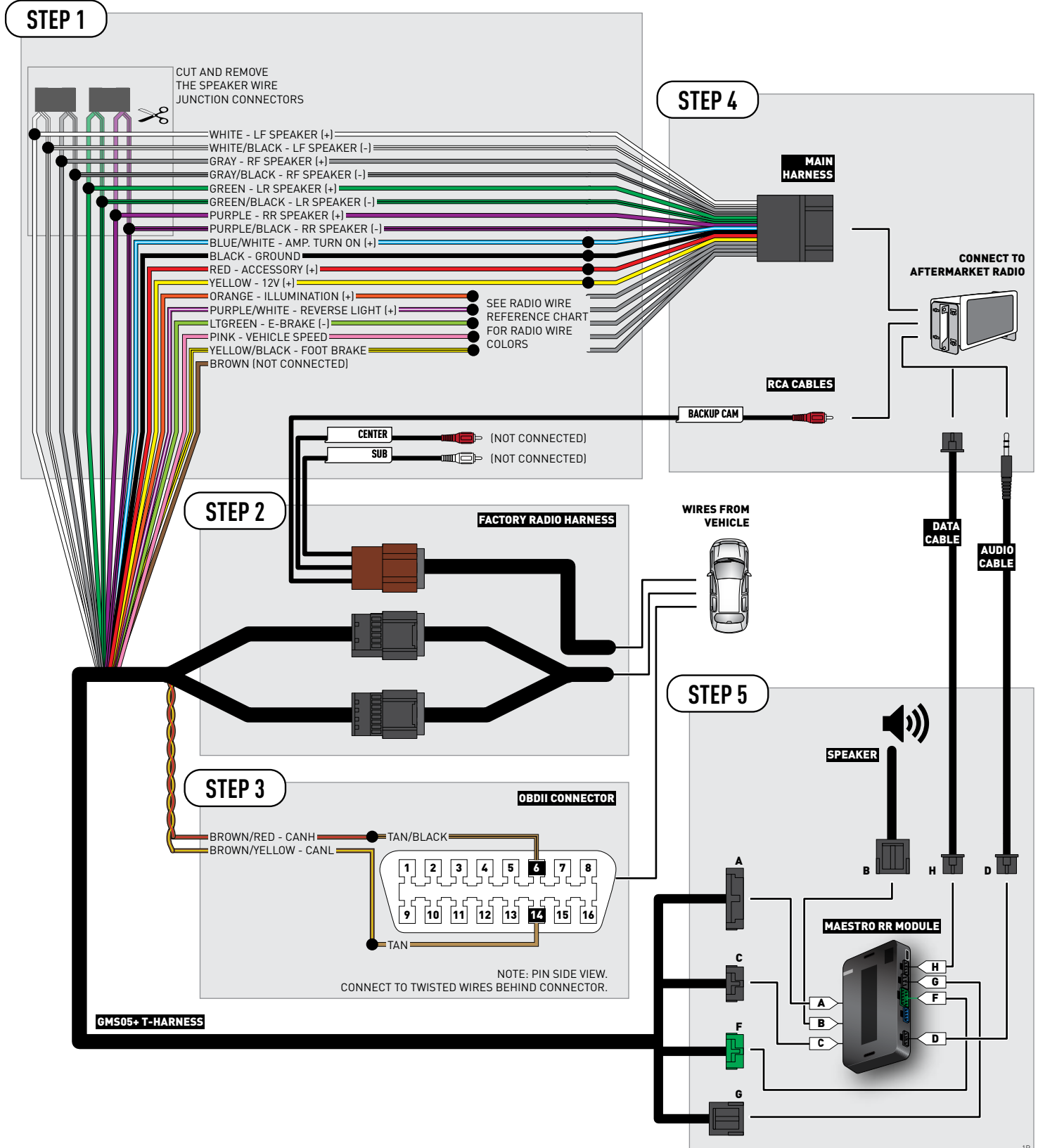

VEHICLE WIRE REFERENCE CHART

Wire Description	Connector Name	Connector Color	Connector Type	Position	Wire Color	Polarity	Wire Location
CanH	OBDII	~	16 pin	06	Tan/Black	(Data)	OBDII connector, under driver side dash
CanL	OBDII	~	16 pin	14	Tan	(Data)	OBDII connector, under driver side dash

RADIO WIRE REFERENCE CHART

Wire Description	Polarity	Wire Color on Maestro T-Harness	Wire Color on Alpine cable	Wire Color on Kenwood cable	Wire Color on Pioneer cable
Illumination	(+)	Orange	N/A	Orange/White	Orange/White
Reverse Light	(+)	Purple/White	Orange/White	Purple/White	Purple/White
E-Brake	(-)	Lt Green	Yellow/Blue	Lt Green	Lt Green
Foot Brake	(+)	Yellow/Black	Yellow/Black	N/A	N/A
VSS (vehicle speed sensor)	(DATA)	Pink	Green/White	N/A	Pink



INSTALL GUIDE CADILLAC ESCALADE 2007-2011

RETAINS STEERING WHEEL CONTROLS, ONSTAR, BLUETOOTH, XM SATELLITE AND MORE!



PRODUCTS REQUIRED

iDatalink Maestro RR Radio Replacement Interface
iDatalink Maestro GM5+ Installation Harness

OPTIONAL ACCESSORIES

None

PROGRAMMED FIRMWARE

ADS-RR(SR)-GMS05-DS

NOTICE: Automotive Data Solutions Inc. (ADS) recommends having this installation performed by a certified technician. Logos and trademarks used here in are the properties of their respective owners.

WELCOME

Congratulations on the purchase of your iDatalink Maestro RR Radio replacement solution. You are now a few simple steps away from enjoying your new car radio with enhanced features.

Before starting your installation, please ensure that your iDatalink Maestro module is programmed with the correct firmware for your vehicle and that you carefully review the install guide.

Please note that Maestro RR will only retain functionalities that were originally available in the vehicle.

NEED HELP?

 **1 866 427-2999**

 **support@idatalink.com**

 **maestro.idatalink.com/support
www.12voltdata.com/forum**

TABLE OF CONTENTS

Before Installing	3
Installation Instructions	4
Wiring Diagram with an Amplifier	5
Wiring Diagram without an Amplifier	6
Vehicle Wire Reference Chart	7
Radio Wire Reference Chart	8

BEFORE INSTALLING

STEP 1

DETERMINE IF YOUR VEHICLE IS EQUIPPED WITH A FACTORY AMPLIFIER:

METHOD 1: Look for the following logos in the vehicle. They are usually on the speaker covers or on the radio unit. If you find any of the following logos Bose, Pioneer or Monsoon, you have a factory amplifier.



METHOD 2: Look for the following sticker in the glove box. This sticker will indicate all the Regular Production Option (RPO) codes. If you find any of the following codes UQA, UQS or UQG, you have a factory amplifier.

SERVICE PARTS IDENTIFICATION										DO NOT REMOVE		
2GCEK19N031344764					143 5 FXWH2Q			CKI5753				
AGI	AG2	AJ1	AL0	AM7	AN3	AU0	AU3	A31	B30	B4U		
B58	B81	B82	CJ3	C49	C7H	DF5	DK7	DL3	DT4	D07		
EVA	E63	FF8	FF9	GT5	G80	JC4	KC4	KNP	KUP	K34		
K47	K68	LQ9	M32	NCI	NEI	NP3	NP5	QCC	P30	QSS		
R4Y	R9U	R9Z	SAF	SLM	TRB	UC6	UK3	UQA	U2K	UFI		
UF3	UK3	VR4	VTV	VXS	V73	XSS	X88	YD6	YD6	YE9		
YSS	ZGC	ZYI	Z60	Z82	ISS	ISZ	4IU	6YT	691	692		
7YT												
BC/CC	U	8555				692						

STEP 2

IF YOUR VEHICLE IS EQUIPPED WITH A FACTORY AMPLIFIER:

Follow the installation instructions and complete the installation as shown in the wiring diagram **with an amplifier** and read the "AMPLIFIER ONLY" note to determine if you should use rca's or level matching circuits.

IF YOUR VEHICLE NOT IS EQUIPPED WITH A FACTORY AMPLIFIER:

Follow the installation instructions and complete the installation as shown in the wiring diagram **without an amplifier**.

INSTALLATION INSTRUCTIONS

STEP 1

- Unbox the aftermarket radio and locate its main harness.
- Connect the wires shown on the next page from aftermarket radio main harness to the GM5+ T-harness and match the wire functions.

STEP 2

- Connect the factory harness to the GM5+ T-harness.

STEP 3

- Access the OBDII connector located under the driver side dashboard.
- Connect the BROWN /RED wire of the GM5+ T-harness to the wire located at pin 6 of the OBDII connector. (See the vehicle wire chart reference for wire colors)
- Connect the BROWN /YELLOW wire of the GM5+ T-harness to the wire located at pin 14 of the OBDII connector. (See the vehicle wire chart reference for wire colors)

STEP 4

- Plug the aftermarket radio harnesses into the aftermarket radio.
- Plug the Data cable to the data port of the aftermarket radio.
- Insert the Audio cable into the iDataLink 3.5 mm audio jack of the aftermarket radio.

STEP 5

- Connect all the harnesses to the Maestro RR module then proceed to module setup.

The module is now ready to be used.

Insert the aftermarket radio in the dashboard housing and test all the functionalities.

Reassemble the dashboard carefully.

AMPLIFIER ONLY

DETERMINE IF YOU SHOULD USE RCA'S OR LEVEL MATCHING CIRCUITS

- If your vehicle is equipped with a factory amplifier you can connect the RCA wiring to the low level outputs of your aftermarket radio, or connect the level matching circuits to the speaker outputs of the aftermarket radio.
- If your aftermarket radio does not have low level outputs, has only a single RCA output, or the RCA output level is 2 volts or less then it is recommended to connect the level matching circuit to the speaker outputs. If the volume does not go loud enough using the RCA connections, the level matching circuits can be used.
- The internal amplifier in some radios is not compatible with the level matching circuit. In these cases, there will be floor noise (hissing or buzzing at low levels) when the level matching circuit is connected. Change to the RCA connections to eliminate this noise.

TROUBLESHOOTING TIPS:

- To reset the module back its factory settings, turn the key to the OFF position then disconnect all connectors from the module. Press and hold the module's programming button and connect all the connectors back to the module. Wait, the module's LED will flash RED rapidly (this may take up to 10 seconds). Release the programming button. Wait, the LED will turn solid GREEN for 2 seconds.
- For technical assistance call 1-866-427-2999 or e-mail "support@idatalink.com". Visit us at "maestro.idatalink.com/support" and "www.12voltdata.com/forum/"

WIRING DIAGRAM *with an Amplifier*



WIRING DIAGRAM *without an Amplifier*



VEHICLE WIRE REFERENCE CHART

Wire Description	Connector Name	Connector Color	Connector Type	Position	Wire Color	Polarity	Wire Location
CanH	OBDII	~	16 pin	06	Tan/Black	(Data)	OBDII connector, under driver side dash
CanL	OBDII	~	16 pin	14	Tan	(Data)	OBDII connector, under driver side dash

RADIO WIRE REFERENCE CHART

Wire Description	Polarity	Wire Color on Maestro T-Harness	Wire Color on Alpine cable	Wire Color on Kenwood cable	Wire Color on Pioneer cable
Illumination	(+)	Orange	N/A	Orange/White	Orange/White
Reverse Light	(+)	Purple/White	Orange/White	Purple/White	Purple/White
E-Brake	(-)	Lt Green	Yellow/Blue	Lt Green	Lt Green
Foot Brake	(+)	Yellow/Black	Yellow/Black	N/A	N/A
VSS (vehicle speed sensor)	(DATA)	Pink	Green/White	N/A	Pink



INSTALL GUIDE CADILLAC ESCALADE WITHOUT NAV 2012-2014

RETAINS STEERING WHEEL CONTROLS, ONSTAR, BLUETOOTH, XM SATELLITE AND MORE!



PRODUCTS REQUIRED

iDatalink Maestro RR Radio Replacement Interface
iDatalink Maestro GM5+ Installation Harness

OPTIONAL ACCESSORIES

None

PROGRAMMED FIRMWARE

ADS-RR(SR)-GMS05-DS

NOTICE: Automotive Data Solutions Inc. (ADS) recommends having this installation performed by a certified technician. Logos and trademarks used here in are the properties of their respective owners.

WELCOME

Congratulations on the purchase of your iDatalink Maestro RR Radio replacement solution. You are now a few simple steps away from enjoying your new car radio with enhanced features.

Before starting your installation, please ensure that your iDatalink Maestro module is programmed with the correct firmware for your vehicle and that you carefully review the install guide.

Please note that Maestro RR will only retain functionalities that were originally available in the vehicle.

NEED HELP?

 **1 866 427-2999**

 support@idatalink.com

 maestro.idatalink.com/support
www.12voltdata.com/forum

TABLE OF CONTENTS

Before Installing	3
Installation Instructions	4
Wiring Diagram with an Amplifier	5
Wiring Diagram without an Amplifier	6
Vehicle Wire Reference Chart	7
Radio Wire Reference Chart	8

BEFORE INSTALLING

STEP 1

DETERMINE IF YOUR VEHICLE IS EQUIPPED WITH A FACTORY AMPLIFIER:

METHOD 1: Look for the following logos in the vehicle. They are usually on the speaker covers or on the radio unit. If you find any of the following logos Bose, Pioneer or Monsoon, you have a factory amplifier.

BOSE

Pioneer

MONSOON

METHOD 2: Look for the following sticker in the glove box. This sticker will indicate all the Regular Production Option (RPO) codes. If you find any of the following codes UQA, UQS or UQG, you have a factory amplifier.

SERVICE PARTS IDENTIFICATION												DO NOT REMOVE		
2GCEK19N031344764						143 5 FXWH2Q			CKI5753					
AGI	AG2	AJ1	AL0	AM7	AN3	AU0	AU3	A31	B30	B4U				
B58	B81	B82	CJ3	C49	C7H	DF5	DK7	DL3	DT4	D07				
EVA	E63	FF8	FF9	GT5	G80	JC4	KC4	KNP	KUP	K34				
K47	K68	LQ9	M32	NCI	NEI	NP3	NP5	OSC	P30	QSS				
R4Y	R9U	R9Z	SAF	SLM	TRB	UC6	UK3	UQA	U2K	UFI				
UF3	UK3	VR4	VTV	VXS	V73	XSS	X88	YD6	YE9					
YSS	ZGC	ZYI	Z60	Z82	ISS	ISZ	4IU	6YT	691	692				
7YT														
BC/CC	U	8555				692								

STEP 2

IF YOUR VEHICLE IS EQUIPPED WITH A FACTORY AMPLIFIER:

Follow the installation instructions and complete the installation as shown in the wiring diagram **with an amplifier** and read the "AMPLIFIER ONLY" note to determine if you should use rca's or level matching circuits.

IF YOUR VEHICLE NOT IS EQUIPPED WITH A FACTORY AMPLIFIER:

Follow the installation instructions and complete the installation as shown in the wiring diagram **without an amplifier**.

INSTALLATION INSTRUCTIONS

STEP 1

- Unbox the aftermarket radio and locate its main harness.
- Connect the wires shown on the next page from aftermarket radio main harness to the GM5+ T-harness and match the wire functions.

STEP 2

- Connect the factory harness to the GM5+ T-harness.

STEP 3

- Access the OBDII connector located under the driver side dashboard.
- Connect the BROWN /RED wire of the GM5+ T-harness to the wire located at pin 6 of the OBDII connector. (See the vehicle wire chart reference for wire colors)
- Connect the BROWN /YELLOW wire of the GM5+ T-harness to the wire located at pin 14 of the OBDII connector. (See the vehicle wire chart reference for wire colors)

STEP 4

- Plug the aftermarket radio harnesses into the aftermarket radio.
- Plug the Data cable to the data port of the aftermarket radio.
- Insert the Audio cable into the iDatalink 3.5 mm audio jack of the aftermarket radio.

STEP 5

- Connect all the harnesses to the Maestro RR module then proceed to module setup.

The module is now ready to be used.

Insert the aftermarket radio in the dashboard housing and test all the functionalities.

Reassemble the dashboard carefully.

AMPLIFIER ONLY

DETERMINE IF YOU SHOULD USE RCA'S OR LEVEL MATCHING CIRCUITS

- If your vehicle is equipped with a factory amplifier you can connect the RCA wiring to the low level outputs of your aftermarket radio, or connect the level matching circuits to the speaker outputs of the aftermarket radio.
- If your aftermarket radio does not have low level outputs, has only a single RCA output, or the RCA output level is 2 volts or less then it is recommended to connect the level matching circuit to the speaker outputs. If the volume does not go loud enough using the RCA connections, the level matching circuits can be used.
- The internal amplifier in some radios is not compatible with the level matching circuit. In these cases, there will be floor noise (hissing or buzzing at low levels) when the level matching circuit is connected. Change to the RCA connections to eliminate this noise.

TROUBLESHOOTING TIPS:

- To reset the module back its factory settings, turn the key to the OFF position then disconnect all connectors from the module. Press and hold the module's programming button and connect all the connectors back to the module. Wait, the module's LED will flash RED rapidly (this may take up to 10 seconds). Release the programming button. Wait, the LED will turn solid GREEN for 2 seconds.
- For technical assistance call 1-866-427-2999 or e-mail "support@idatalink.com". Visit us at "maestro.idatalink.com/support" and "www.12voltdata.com/forum/"

WIRING DIAGRAM *with an Amplifier*



WIRING DIAGRAM *without an Amplifier*

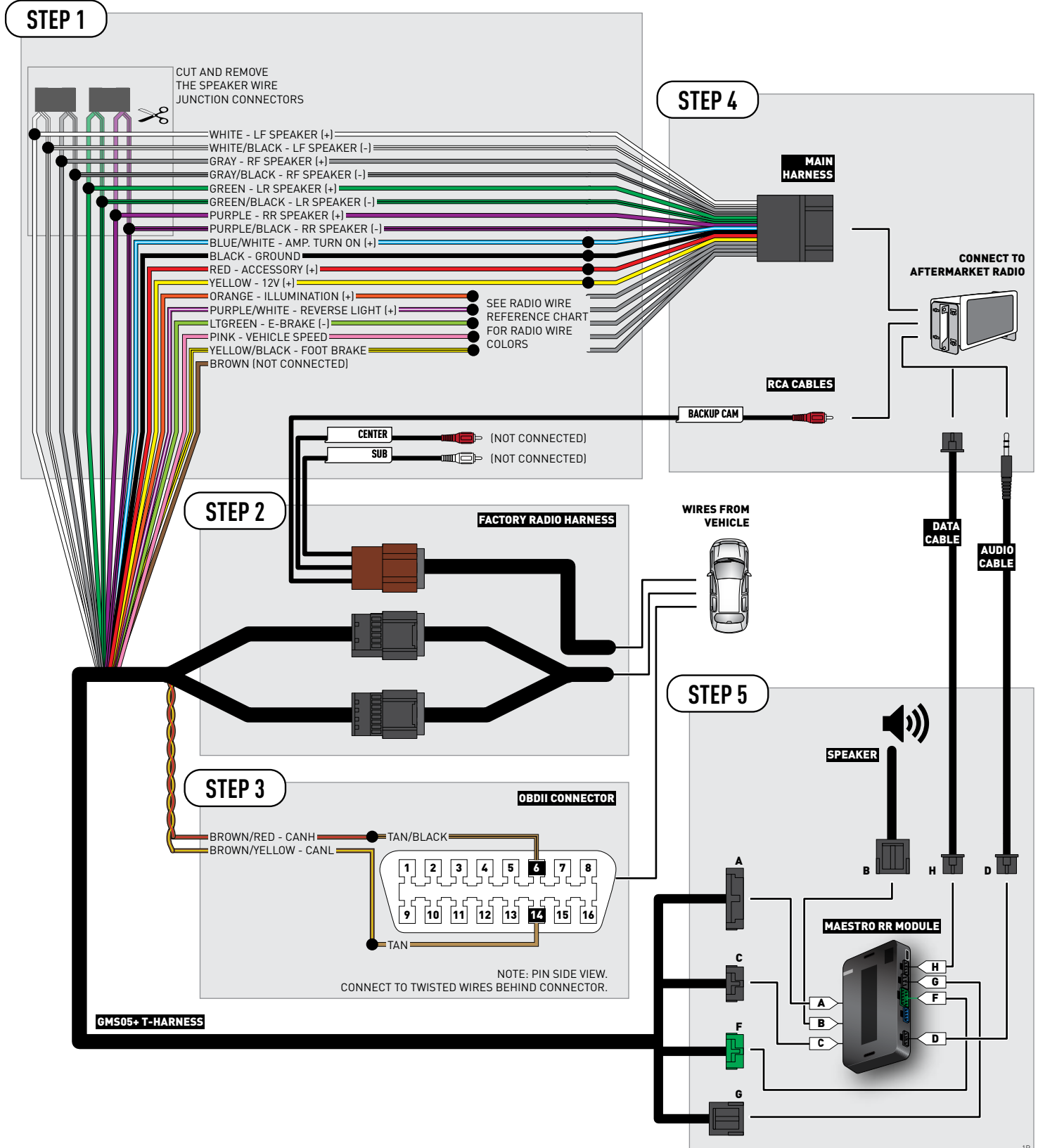

VEHICLE WIRE REFERENCE CHART

Wire Description	Connector Name	Connector Color	Connector Type	Position	Wire Color	Polarity	Wire Location
CanH	OBDII	~	16 pin	06	Tan/Black	(Data)	OBDII connector, under driver side dash
CanL	OBDII	~	16 pin	14	Tan	(Data)	OBDII connector, under driver side dash

RADIO WIRE REFERENCE CHART

Wire Description	Polarity	Wire Color on Maestro T-Harness	Wire Color on Alpine cable	Wire Color on Kenwood cable	Wire Color on Pioneer cable
Illumination	(+)	Orange	N/A	Orange/White	Orange/White
Reverse Light	(+)	Purple/White	Orange/White	Purple/White	Purple/White
E-Brake	(-)	Lt Green	Yellow/Blue	Lt Green	Lt Green
Foot Brake	(+)	Yellow/Black	Yellow/Black	N/A	N/A
VSS (vehicle speed sensor)	(DATA)	Pink	Green/White	N/A	Pink



INSTALL GUIDE CHEVROLET AVALANCHE 2007-2011

RETAINS STEERING WHEEL CONTROLS, ONSTAR, BLUETOOTH, XM SATELLITE AND MORE!



PRODUCTS REQUIRED

iDatalink Maestro RR Radio Replacement Interface
iDatalink Maestro GM5+ Installation Harness

OPTIONAL ACCESSORIES

None

PROGRAMMED FIRMWARE

ADS-RR(SR)-GMS05-DS

NOTICE: Automotive Data Solutions Inc. (ADS) recommends having this installation performed by a certified technician. Logos and trademarks used here in are the properties of their respective owners.

WELCOME

Congratulations on the purchase of your iDatalink Maestro RR Radio replacement solution. You are now a few simple steps away from enjoying your new car radio with enhanced features.

Before starting your installation, please ensure that your iDatalink Maestro module is programmed with the correct firmware for your vehicle and that you carefully review the install guide.

Please note that Maestro RR will only retain functionalities that were originally available in the vehicle.

NEED HELP?

 **1 866 427-2999**

 support@idatalink.com

 maestro.idatalink.com/support
www.12voltdata.com/forum

TABLE OF CONTENTS

Before Installing	3
Installation Instructions	4
Wiring Diagram with an Amplifier	5
Wiring Diagram without an Amplifier	6
Vehicle Wire Reference Chart	7
Radio Wire Reference Chart	8

BEFORE INSTALLING

STEP 1

DETERMINE IF YOUR VEHICLE IS EQUIPPED WITH A FACTORY AMPLIFIER:

METHOD 1: Look for the following logos in the vehicle. They are usually on the speaker covers or on the radio unit. If you find any of the following logos Bose, Pioneer or Monsoon, you have a factory amplifier.



METHOD 2: Look for the following sticker in the glove box. This sticker will indicate all the Regular Production Option (RPO) codes. If you find any of the following codes UQA, UQS or UQG, you have a factory amplifier.

SERVICE PARTS IDENTIFICATION												DO NOT REMOVE	
2GCEK19N031344764						143 5 FXWH2Q			CKI5753				
AGI	AG2	AJ1	AL0	AM7	AN3	AU0	AU3	A31	B30	B4U			
B58	B81	B82	CJ3	C49	C7H	DF5	DK7	DL3	DT4	D07			
EVA	E63	FF8	FF9	GT5	G80	JC4	KC4	KNP	KUP	K34			
K47	K68	LQ9	M32	NCI	NEI	NP3	NP5	QCC	P30	QSS			
R4Y	R9U	R9Z	SAF	SLM	TRB	UC6	UK3	UQA	U2K	UFI			
UF3	UK3	VR4	VTV	VXS	V73	XSS	X88	YD6	YD6	YE9			
YSS	ZGC	ZYI	Z60	Z82	ISS	ISZ	4IU	6YT	691	692			
7YT													
BC/CC	U	8555				692							

STEP 2

IF YOUR VEHICLE IS EQUIPPED WITH A FACTORY AMPLIFIER:

Follow the installation instructions and complete the installation as shown in the wiring diagram **with an amplifier** and read the "AMPLIFIER ONLY" note to determine if you should use rca's or level matching circuits.

IF YOUR VEHICLE NOT IS EQUIPPED WITH A FACTORY AMPLIFIER:

Follow the installation instructions and complete the installation as shown in the wiring diagram **without an amplifier**.

INSTALLATION INSTRUCTIONS

STEP 1

- Unbox the aftermarket radio and locate its main harness.
- Connect the wires shown on the next page from aftermarket radio main harness to the GM5+ T-harness and match the wire functions.

STEP 2

- Connect the factory harness to the GM5+ T-harness.

STEP 3

- Access the OBDII connector located under the driver side dashboard.
- Connect the BROWN /RED wire of the GM5+ T-harness to the wire located at pin 6 of the OBDII connector. (See the vehicle wire chart reference for wire colors)
- Connect the BROWN /YELLOW wire of the GM5+ T-harness to the wire located at pin 14 of the OBDII connector. (See the vehicle wire chart reference for wire colors)

STEP 4

- Plug the aftermarket radio harnesses into the aftermarket radio.
- Plug the Data cable to the data port of the aftermarket radio.
- Insert the Audio cable into the iDatalink 3.5 mm audio jack of the aftermarket radio.

STEP 5

- Connect all the harnesses to the Maestro RR module then proceed to module setup.

The module is now ready to be used.

Insert the aftermarket radio in the dashboard housing and test all the functionalities.

Reassemble the dashboard carefully.

AMPLIFIER ONLY

DETERMINE IF YOU SHOULD USE RCA'S OR LEVEL MATCHING CIRCUITS

- If your vehicle is equipped with a factory amplifier you can connect the RCA wiring to the low level outputs of your aftermarket radio, or connect the level matching circuits to the speaker outputs of the aftermarket radio.
- If your aftermarket radio does not have low level outputs, has only a single RCA output, or the RCA output level is 2 volts or less then it is recommended to connect the level matching circuit to the speaker outputs. If the volume does not go loud enough using the RCA connections, the level matching circuits can be used.
- The internal amplifier in some radios is not compatible with the level matching circuit. In these cases, there will be floor noise (hissing or buzzing at low levels) when the level matching circuit is connected. Change to the RCA connections to eliminate this noise.

TROUBLESHOOTING TIPS:

- To reset the module back its factory settings, turn the key to the OFF position then disconnect all connectors from the module. Press and hold the module's programming button and connect all the connectors back to the module. Wait, the module's LED will flash RED rapidly (this may take up to 10 seconds). Release the programming button. Wait, the LED will turn solid GREEN for 2 seconds.
- For technical assistance call 1-866-427-2999 or e-mail "support@idatalink.com". Visit us at "maestro.idatalink.com/support" and "www.12voltdata.com/forum/"

WIRING DIAGRAM *with an Amplifier*



WIRING DIAGRAM *without an Amplifier*

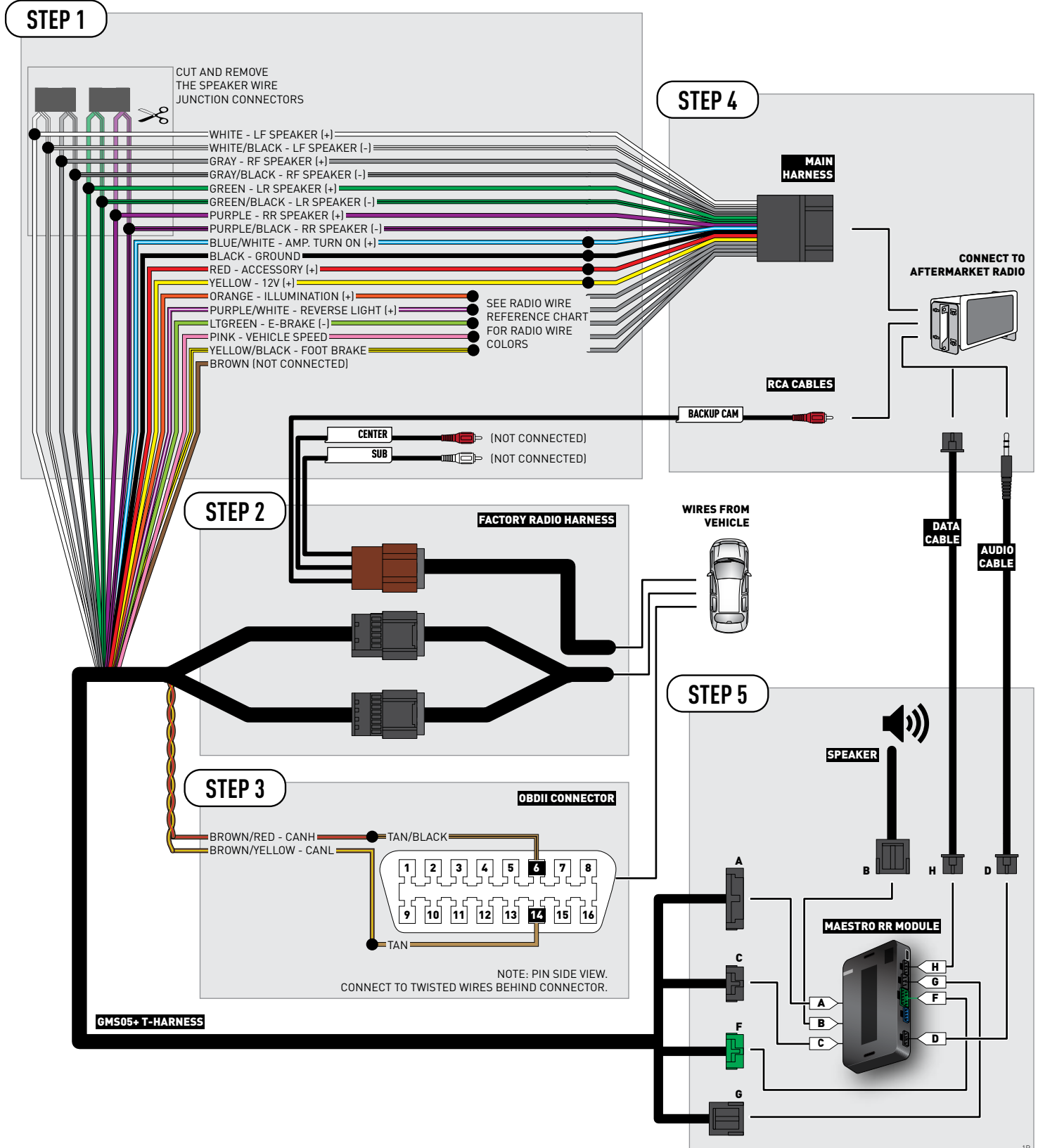

VEHICLE WIRE REFERENCE CHART

Wire Description	Connector Name	Connector Color	Connector Type	Position	Wire Color	Polarity	Wire Location
CanH	OBDII	~	16 pin	06	Tan/Black	(Data)	OBDII connector, under driver side dash
CanL	OBDII	~	16 pin	14	Tan	(Data)	OBDII connector, under driver side dash

RADIO WIRE REFERENCE CHART

Wire Description	Polarity	Wire Color on Maestro T-Harness	Wire Color on Alpine cable	Wire Color on Kenwood cable	Wire Color on Pioneer cable
Illumination	(+)	Orange	N/A	Orange/White	Orange/White
Reverse Light	(+)	Purple/White	Orange/White	Purple/White	Purple/White
E-Brake	(-)	Lt Green	Yellow/Blue	Lt Green	Lt Green
Foot Brake	(+)	Yellow/Black	Yellow/Black	N/A	N/A
VSS (vehicle speed sensor)	(DATA)	Pink	Green/White	N/A	Pink



INSTALL GUIDE

CHEVROLET AVALANCHE

WITHOUT NAV 2012-2013

RETAINS STEERING WHEEL CONTROLS, ONSTAR, BLUETOOTH, XM SATELLITE AND MORE!



PRODUCTS REQUIRED

iDatalink Maestro RR Radio Replacement Interface
iDatalink Maestro GM5+ Installation Harness

OPTIONAL ACCESSORIES

None

PROGRAMMED FIRMWARE

ADS-RR(SR)-GMS05-DS

NOTICE: Automotive Data Solutions Inc. (ADS) recommends having this installation performed by a certified technician. Logos and trademarks used here in are the properties of their respective owners.

WELCOME

Congratulations on the purchase of your iDatalink Maestro RR Radio replacement solution. You are now a few simple steps away from enjoying your new car radio with enhanced features.

Before starting your installation, please ensure that your iDatalink Maestro module is programmed with the correct firmware for your vehicle and that you carefully review the install guide.

Please note that Maestro RR will only retain functionalities that were originally available in the vehicle.

NEED HELP?

 **1 866 427-2999**

 **support@idatalink.com**

 **maestro.idatalink.com/support
www.12voltdata.com/forum**

TABLE OF CONTENTS

Before Installing	3
Installation Instructions	4
Wiring Diagram with an Amplifier	5
Wiring Diagram without an Amplifier	6
Vehicle Wire Reference Chart	7
Radio Wire Reference Chart	8

BEFORE INSTALLING

STEP 1

DETERMINE IF YOUR VEHICLE IS EQUIPPED WITH A FACTORY AMPLIFIER:

METHOD 1: Look for the following logos in the vehicle. They are usually on the speaker covers or on the radio unit. If you find any of the following logos Bose, Pioneer or Monsoon, you have a factory amplifier.



METHOD 2: Look for the following sticker in the glove box. This sticker will indicate all the Regular Production Option (RPO) codes. If you find any of the following codes UQA, UQS or UQG, you have a factory amplifier.

SERVICE PARTS IDENTIFICATION												DO NOT REMOVE	
2GCEK19N031344764						143 5 FXWH2Q			CKI5753				
AGI	AG2	AJ1	AL0	AM7	AN3	AU0	AU3	A31	B30	B4U			
B58	B81	B82	CJ3	C49	C7H	DF5	DK7	DL3	DT4	D07			
EVA	E63	FF8	FF9	GT5	G80	JC4	KC4	KNP	KUP	K34			
K47	K68	LQ9	M32	NCI	NEI	NP3	NP5	QCC	P30	QSS			
R4Y	R9U	R9Z	SAF	SLM	TRB	UC6	UK3	UQA	U2K	UFI			
UF3	UK3	VR4	VTV	VXS	V73	XSS	X88	YD6	YE9				
YSS	ZGC	ZYI	Z60	Z82	ISS	ISZ	4IU	6YT	691	692			
7YT													
BC/CC	U	8555				692							

STEP 2

IF YOUR VEHICLE IS EQUIPPED WITH A FACTORY AMPLIFIER:

Follow the installation instructions and complete the installation as shown in the wiring diagram **with an amplifier** and read the "AMPLIFIER ONLY" note to determine if you should use rca's or level matching circuits.

IF YOUR VEHICLE NOT IS EQUIPPED WITH A FACTORY AMPLIFIER:

Follow the installation instructions and complete the installation as shown in the wiring diagram **without an amplifier**.

INSTALLATION INSTRUCTIONS

STEP 1

- Unbox the aftermarket radio and locate its main harness.
- Connect the wires shown on the next page from aftermarket radio main harness to the GM5+ T-harness and match the wire functions.

STEP 2

- Connect the factory harness to the GM5+ T-harness.

STEP 3

- Access the OBDII connector located under the driver side dashboard.
- Connect the BROWN /RED wire of the GM5+ T-harness to the wire located at pin 6 of the OBDII connector. (See the vehicle wire chart reference for wire colors)
- Connect the BROWN /YELLOW wire of the GM5+ T-harness to the wire located at pin 14 of the OBDII connector. (See the vehicle wire chart reference for wire colors)

STEP 4

- Plug the aftermarket radio harnesses into the aftermarket radio.
- Plug the Data cable to the data port of the aftermarket radio.
- Insert the Audio cable into the iDataLink 3.5 mm audio jack of the aftermarket radio.

STEP 5

- Connect all the harnesses to the Maestro RR module then proceed to module setup.

The module is now ready to be used.

Insert the aftermarket radio in the dashboard housing and test all the functionalities.

Reassemble the dashboard carefully.

AMPLIFIER ONLY

DETERMINE IF YOU SHOULD USE RCA'S OR LEVEL MATCHING CIRCUITS

- If your vehicle is equipped with a factory amplifier you can connect the RCA wiring to the low level outputs of your aftermarket radio, or connect the level matching circuits to the speaker outputs of the aftermarket radio.
- If your aftermarket radio does not have low level outputs, has only a single RCA output, or the RCA output level is 2 volts or less then it is recommended to connect the level matching circuit to the speaker outputs. If the volume does not go loud enough using the RCA connections, the level matching circuits can be used.
- The internal amplifier in some radios is not compatible with the level matching circuit. In these cases, there will be floor noise (hissing or buzzing at low levels) when the level matching circuit is connected. Change to the RCA connections to eliminate this noise.

TROUBLESHOOTING TIPS:

- To reset the module back its factory settings, turn the key to the OFF position then disconnect all connectors from the module. Press and hold the module's programming button and connect all the connectors back to the module. Wait, the module's LED will flash RED rapidly (this may take up to 10 seconds). Release the programming button. Wait, the LED will turn solid GREEN for 2 seconds.
- For technical assistance call 1-866-427-2999 or e-mail "support@idatalink.com". Visit us at "maestro.idatalink.com/support" and "www.12voltdata.com/forum/"

WIRING DIAGRAM *with an Amplifier*



WIRING DIAGRAM *without an Amplifier*

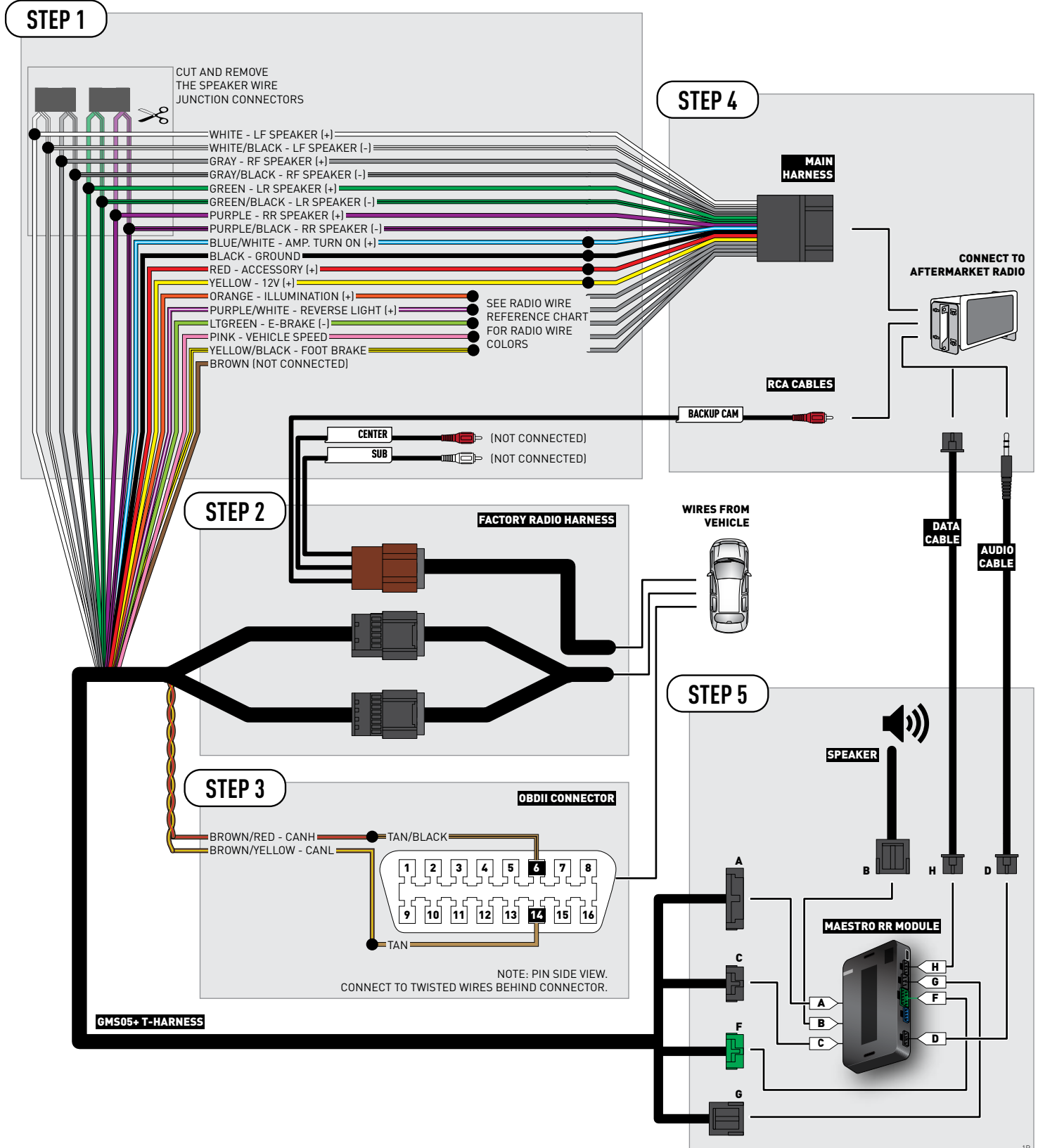

VEHICLE WIRE REFERENCE CHART

Wire Description	Connector Name	Connector Color	Connector Type	Position	Wire Color	Polarity	Wire Location
CanH	OBDII	~	16 pin	06	Tan/Black	(Data)	OBDII connector, under driver side dash
CanL	OBDII	~	16 pin	14	Tan	(Data)	OBDII connector, under driver side dash

RADIO WIRE REFERENCE CHART

Wire Description	Polarity	Wire Color on Maestro T-Harness	Wire Color on Alpine cable	Wire Color on Kenwood cable	Wire Color on Pioneer cable
Illumination	(+)	Orange	N/A	Orange/White	Orange/White
Reverse Light	(+)	Purple/White	Orange/White	Purple/White	Purple/White
E-Brake	(-)	Lt Green	Yellow/Blue	Lt Green	Lt Green
Foot Brake	(+)	Yellow/Black	Yellow/Black	N/A	N/A
VSS (vehicle speed sensor)	(DATA)	Pink	Green/White	N/A	Pink



INSTALL GUIDE CHEVROLET EQUINOX 2007-2009

RETAINS STEERING WHEEL CONTROLS, ONSTAR, BLUETOOTH, XM SATELLITE AND MORE!



PRODUCTS REQUIRED

iDatalink Maestro RR Radio Replacement Interface
iDatalink Maestro GM5+ Installation Harness

OPTIONAL ACCESSORIES

None

PROGRAMMED FIRMWARE

ADS-RR(SR)-GMS05-DS

NOTICE: Automotive Data Solutions Inc. (ADS) recommends having this installation performed by a certified technician. Logos and trademarks used here in are the properties of their respective owners.

WELCOME

Congratulations on the purchase of your iDatalink Maestro RR Radio replacement solution. You are now a few simple steps away from enjoying your new car radio with enhanced features.

Before starting your installation, please ensure that your iDatalink Maestro module is programmed with the correct firmware for your vehicle and that you carefully review the install guide.

Please note that Maestro RR will only retain functionalities that were originally available in the vehicle.

NEED HELP?

 **1 866 427-2999**

 **support@idatalink.com**

 **maestro.idatalink.com/support**
www.12voltdata.com/forum

TABLE OF CONTENTS

Before Installing	3
Installation Instructions	4
Wiring Diagram with an Amplifier	5
Wiring Diagram without an Amplifier	6
Vehicle Wire Reference Chart	7
Radio Wire Reference Chart	8

BEFORE INSTALLING

STEP 1

DETERMINE IF YOUR VEHICLE IS EQUIPPED WITH A FACTORY AMPLIFIER:

METHOD 1: Look for the following logos in the vehicle. They are usually on the speaker covers or on the radio unit. If you find any of the following logos Bose, Pioneer or Monsoon, you have a factory amplifier.



METHOD 2: Look for the following sticker in the glove box. This sticker will indicate all the Regular Production Option (RPO) codes. If you find any of the following codes UQA, UQS or UQG, you have a factory amplifier.

SERVICE PARTS IDENTIFICATION												DO NOT REMOVE		
2GCEK19N031344764						143 5 FXWH2Q			CKI5753					
AGI	AG2	AJ1	AL0	AM7	AN3	AU0	AU3	A31	B30	B4U				
B58	B81	B82	CJ3	C49	C7H	DF5	DK7	DL3	DT4	D07				
EVA	E63	FF8	FF9	GT5	G80	JC4	KC4	KNP	KUP	K34				
K47	K68	LQ9	M32	NCI	NEI	NP3	NP5	QCC	P30	QSS				
R4Y	R9U	R9Z	SAF	SLM	TRB	UC6	UK3	UQA	U2K	UFI				
UF3	UK3	VR4	VTV	VXS	V73	XSS	X88	YD6	YE9					
YSS	ZGC	ZYI	Z60	Z82	ISS	ISZ	4IU	6YT	691	692				
7YT														
BC/CC	U	8555				692								

STEP 2

IF YOUR VEHICLE IS EQUIPPED WITH A FACTORY AMPLIFIER:

Follow the installation instructions and complete the installation as shown in the wiring diagram **with an amplifier** and read the "AMPLIFIER ONLY" note to determine if you should use rca's or level matching circuits.

IF YOUR VEHICLE NOT IS EQUIPPED WITH A FACTORY AMPLIFIER:

Follow the installation instructions and complete the installation as shown in the wiring diagram **without an amplifier**.

INSTALLATION INSTRUCTIONS

STEP 1

- Unbox the aftermarket radio and locate its main harness.
- Connect the wires shown on the next page from aftermarket radio main harness to the GM5+ T-harness and match the wire functions.

STEP 2

- Connect the factory harness to the GM5+ T-harness.

STEP 3

- Access the OBDII connector located under the driver side dashboard.
- Connect the BROWN /RED wire of the GM5+ T-harness to the wire located at pin 6 of the OBDII connector. (See the vehicle wire chart reference for wire colors)
- Connect the BROWN /YELLOW wire of the GM5+ T-harness to the wire located at pin 14 of the OBDII connector. (See the vehicle wire chart reference for wire colors)

STEP 4

- Plug the aftermarket radio harnesses into the aftermarket radio.
- Plug the Data cable to the data port of the aftermarket radio.
- Insert the Audio cable into the iDataLink 3.5 mm audio jack of the aftermarket radio.

STEP 5

- Connect all the harnesses to the Maestro RR module then proceed to module setup.

The module is now ready to be used.

Insert the aftermarket radio in the dashboard housing and test all the functionalities.

Reassemble the dashboard carefully.

AMPLIFIER ONLY

DETERMINE IF YOU SHOULD USE RCA'S OR LEVEL MATCHING CIRCUITS

- If your vehicle is equipped with a factory amplifier you can connect the RCA wiring to the low level outputs of your aftermarket radio, or connect the level matching circuits to the speaker outputs of the aftermarket radio.
- If your aftermarket radio does not have low level outputs, has only a single RCA output, or the RCA output level is 2 volts or less then it is recommended to connect the level matching circuit to the speaker outputs. If the volume does not go loud enough using the RCA connections, the level matching circuits can be used.
- The internal amplifier in some radios is not compatible with the level matching circuit. In these cases, there will be floor noise (hissing or buzzing at low levels) when the level matching circuit is connected. Change to the RCA connections to eliminate this noise.

TROUBLESHOOTING TIPS:

- To reset the module back its factory settings, turn the key to the OFF position then disconnect all connectors from the module. Press and hold the module's programming button and connect all the connectors back to the module. Wait, the module's LED will flash RED rapidly (this may take up to 10 seconds). Release the programming button. Wait, the LED will turn solid GREEN for 2 seconds.
- For technical assistance call 1-866-427-2999 or e-mail "support@idatalink.com". Visit us at "maestro.idatalink.com/support" and "www.12voltdata.com/forum/"

WIRING DIAGRAM *with an Amplifier*



WIRING DIAGRAM *without an Amplifier*



VEHICLE WIRE REFERENCE CHART

Wire Description	Connector Name	Connector Color	Connector Type	Position	Wire Color	Polarity	Wire Location
CanH	OBDII	~	16 pin	06	Tan/Black	(Data)	OBDII connector, under driver side dash
CanL	OBDII	~	16 pin	14	Tan	(Data)	OBDII connector, under driver side dash

RADIO WIRE REFERENCE CHART

Wire Description	Polarity	Wire Color on Maestro T-Harness	Wire Color on Alpine cable	Wire Color on Kenwood cable	Wire Color on Pioneer cable
Illumination	(+)	Orange	N/A	Orange/White	Orange/White
Reverse Light	(+)	Purple/White	Orange/White	Purple/White	Purple/White
E-Brake	(-)	Lt Green	Yellow/Blue	Lt Green	Lt Green
Foot Brake	(+)	Yellow/Black	Yellow/Black	N/A	N/A
VSS (vehicle speed sensor)	(DATA)	Pink	Green/White	N/A	Pink



INSTALL GUIDE CHEVROLET EXPRESS 2008-2016

RETAINS STEERING WHEEL CONTROLS, ONSTAR, BLUETOOTH, XM SATELLITE AND MORE!



PRODUCTS REQUIRED

iDatalink Maestro RR Radio Replacement Interface
iDatalink Maestro GM5+ Installation Harness

OPTIONAL ACCESSORIES

None

PROGRAMMED FIRMWARE

ADS-RR(SR)-GMS05-DS

NOTICE: Automotive Data Solutions Inc. (ADS) recommends having this installation performed by a certified technician. Logos and trademarks used here in are the properties of their respective owners.

WELCOME

Congratulations on the purchase of your iDatalink Maestro RR Radio replacement solution. You are now a few simple steps away from enjoying your new car radio with enhanced features.

Before starting your installation, please ensure that your iDatalink Maestro module is programmed with the correct firmware for your vehicle and that you carefully review the install guide.

Please note that Maestro RR will only retain functionalities that were originally available in the vehicle.

NEED HELP?

 **1 866 427-2999**

 support@idatalink.com

 maestro.idatalink.com/support
www.12voltdata.com/forum

TABLE OF CONTENTS

Before Installing	3
Installation Instructions	4
Wiring Diagram with an Amplifier	5
Wiring Diagram without an Amplifier	6
Vehicle Wire Reference Chart	7
Radio Wire Reference Chart	8

BEFORE INSTALLING

STEP 1

DETERMINE IF YOUR VEHICLE IS EQUIPPED WITH A FACTORY AMPLIFIER:

METHOD 1: Look for the following logos in the vehicle. They are usually on the speaker covers or on the radio unit. If you find any of the following logos Bose, Pioneer or Monsoon, you have a factory amplifier.



METHOD 2: Look for the following sticker in the glove box. This sticker will indicate all the Regular Production Option (RPO) codes. If you find any of the following codes UQA, UQS or UQG, you have a factory amplifier.

SERVICE PARTS IDENTIFICATION												DO NOT REMOVE	
2GCEK19N031344764						143 5 FXWH2Q			CKI5753				
AGI	AG2	AJ1	AL0	AM7	AN3	AU0	AU3	A31	B30	B4U			
B58	B81	B82	CJ3	C49	C7H	DF5	DK7	DL3	DT4	D07			
EVA	E63	FF8	FF9	GT5	G80	JC4	KC4	KNP	KUP	K34			
K47	K68	LQ9	M32	NCI	NEI	NP3	NP5	QCC	P30	QSS			
R4Y	R9U	R9Z	SAF	SLM	TRB	UC6	UK3	UQA	U2K	UFI			
UF3	UK3	VR4	VTV	VXS	V73	XSS	X88	YD6	YE9				
YSS	ZGC	ZYI	Z60	Z82	ISS	ISZ	4IU	6YT	691	692			
7YT													
BC/CC		U	8555			692							

STEP 2

IF YOUR VEHICLE IS EQUIPPED WITH A FACTORY AMPLIFIER:

Follow the installation instructions and complete the installation as shown in the wiring diagram **with an amplifier** and read the "AMPLIFIER ONLY" note to determine if you should use rca's or level matching circuits.

IF YOUR VEHICLE NOT IS EQUIPPED WITH A FACTORY AMPLIFIER:

Follow the installation instructions and complete the installation as shown in the wiring diagram **without an amplifier**.

INSTALLATION INSTRUCTIONS

STEP 1

- Unbox the aftermarket radio and locate its main harness.
- Connect the wires shown on the next page from aftermarket radio main harness to the GM5+ T-harness and match the wire functions.

STEP 2

- Connect the factory harness to the GM5+ T-harness.

STEP 3

- Access the OBDII connector located under the driver side dashboard.
- Connect the BROWN /RED wire of the GM5+ T-harness to the wire located at pin 6 of the OBDII connector. (See the vehicle wire chart reference for wire colors)
- Connect the BROWN /YELLOW wire of the GM5+ T-harness to the wire located at pin 14 of the OBDII connector. (See the vehicle wire chart reference for wire colors)

STEP 4

- Plug the aftermarket radio harnesses into the aftermarket radio.
- Plug the Data cable to the data port of the aftermarket radio.
- Insert the Audio cable into the iDatalink 3.5 mm audio jack of the aftermarket radio.

STEP 5

- Connect all the harnesses to the Maestro RR module then proceed to module setup.

The module is now ready to be used.

Insert the aftermarket radio in the dashboard housing and test all the functionalities.

Reassemble the dashboard carefully.

AMPLIFIER ONLY

DETERMINE IF YOU SHOULD USE RCA'S OR LEVEL MATCHING CIRCUITS

- If your vehicle is equipped with a factory amplifier you can connect the RCA wiring to the low level outputs of your aftermarket radio, or connect the level matching circuits to the speaker outputs of the aftermarket radio.
- If your aftermarket radio does not have low level outputs, has only a single RCA output, or the RCA output level is 2 volts or less then it is recommended to connect the level matching circuit to the speaker outputs. If the volume does not go loud enough using the RCA connections, the level matching circuits can be used.
- The internal amplifier in some radios is not compatible with the level matching circuit. In these cases, there will be floor noise (hissing or buzzing at low levels) when the level matching circuit is connected. Change to the RCA connections to eliminate this noise.

TROUBLESHOOTING TIPS:

- To reset the module back its factory settings, turn the key to the OFF position then disconnect all connectors from the module. Press and hold the module's programming button and connect all the connectors back to the module. Wait, the module's LED will flash RED rapidly (this may take up to 10 seconds). Release the programming button. Wait, the LED will turn solid GREEN for 2 seconds.
- For technical assistance call 1-866-427-2999 or e-mail "support@idatalink.com". Visit us at "maestro.idatalink.com/support" and "www.12voltdata.com/forum/"

WIRING DIAGRAM *with an Amplifier*



WIRING DIAGRAM *without an Amplifier*



VEHICLE WIRE REFERENCE CHART

Wire Description	Connector Name	Connector Color	Connector Type	Position	Wire Color	Polarity	Wire Location
CanH	OBDII	~	16 pin	06	Tan/Black	(Data)	OBDII connector, under driver side dash
CanL	OBDII	~	16 pin	14	Tan	(Data)	OBDII connector, under driver side dash

RADIO WIRE REFERENCE CHART

Wire Description	Polarity	Wire Color on Maestro T-Harness	Wire Color on Alpine cable	Wire Color on Kenwood cable	Wire Color on Pioneer cable
Illumination	(+)	Orange	N/A	Orange/White	Orange/White
Reverse Light	(+)	Purple/White	Orange/White	Purple/White	Purple/White
E-Brake	(-)	Lt Green	Yellow/Blue	Lt Green	Lt Green
Foot Brake	(+)	Yellow/Black	Yellow/Black	N/A	N/A
VSS (vehicle speed sensor)	(DATA)	Pink	Green/White	N/A	Pink



INSTALL GUIDE CHEVROLET IMPALA 2006-2013

RETAINS STEERING WHEEL CONTROLS, ONSTAR, BLUETOOTH, XM SATELLITE AND MORE!



PRODUCTS REQUIRED

iDatalink Maestro RR Radio Replacement Interface
iDatalink Maestro GM5+ Installation Harness

OPTIONAL ACCESSORIES

None

PROGRAMMED FIRMWARE

ADS-RR(SR)-GMS05-DS

NOTICE: Automotive Data Solutions Inc. (ADS) recommends having this installation performed by a certified technician. Logos and trademarks used here in are the properties of their respective owners.

WELCOME

Congratulations on the purchase of your iDatalink Maestro RR Radio replacement solution. You are now a few simple steps away from enjoying your new car radio with enhanced features.

Before starting your installation, please ensure that your iDatalink Maestro module is programmed with the correct firmware for your vehicle and that you carefully review the install guide.

Please note that Maestro RR will only retain functionalities that were originally available in the vehicle.

NEED HELP?

 **1 866 427-2999**

 support@idatalink.com

 maestro.idatalink.com/support
www.12voltdata.com/forum

TABLE OF CONTENTS

Before Installing	3
Installation Instructions	4
Wiring Diagram with an Amplifier	5
Wiring Diagram without an Amplifier	6
Vehicle Wire Reference Chart	7
Radio Wire Reference Chart	8

BEFORE INSTALLING

STEP 1

DETERMINE IF YOUR VEHICLE IS EQUIPPED WITH A FACTORY AMPLIFIER:

METHOD 1: Look for the following logos in the vehicle. They are usually on the speaker covers or on the radio unit. If you find any of the following logos Bose, Pioneer or Monsoon, you have a factory amplifier.



METHOD 2: Look for the following sticker in the glove box. This sticker will indicate all the Regular Production Option (RPO) codes. If you find any of the following codes UQA, UQS or UQG, you have a factory amplifier.

SERVICE PARTS IDENTIFICATION												DO NOT REMOVE	
2GCEK19N031344764						143 5 FXWH2Q			CKI5753				
AGI	AG2	AJ1	AL0	AM7	AN3	AU0	AU3	A31	B30	B4U			
B58	B81	B82	CJ3	C49	C7H	DF5	DK7	DL3	DT4	D07			
EVA	E63	FF8	FF9	GT5	G80	JC4	KC4	KNP	KUP	K34			
K47	K68	LQ9	M32	NCI	NEI	NP3	NP5	QCC	P30	QSS			
R4Y	R9U	R9Z	SAF	SLM	TRB	UC6	UK3	UQA	U2K	UFI			
UF3	UK3	VR4	VTV	VXS	V73	XSS	X88	YD6	YE9				
YSS	ZGC	ZYI	Z60	Z82	ISS	ISZ	4IU	6YT	691	692			
7YT													
BC/CC	U	8555				692							

STEP 2

IF YOUR VEHICLE IS EQUIPPED WITH A FACTORY AMPLIFIER:

Follow the installation instructions and complete the installation as shown in the wiring diagram **with an amplifier** and read the "AMPLIFIER ONLY" note to determine if you should use rca's or level matching circuits.

IF YOUR VEHICLE NOT IS EQUIPPED WITH A FACTORY AMPLIFIER:

Follow the installation instructions and complete the installation as shown in the wiring diagram **without an amplifier**.

INSTALLATION INSTRUCTIONS

STEP 1

- Unbox the aftermarket radio and locate its main harness.
- Connect the wires shown on the next page from aftermarket radio main harness to the GM5+ T-harness and match the wire functions.

STEP 2

- Connect the factory harness to the GM5+ T-harness.

STEP 3

- Access the OBDII connector located under the driver side dashboard.
- Connect the BROWN /RED wire of the GM5+ T-harness to the wire located at pin 6 of the OBDII connector. (See the vehicle wire chart reference for wire colors)
- Connect the BROWN /YELLOW wire of the GM5+ T-harness to the wire located at pin 14 of the OBDII connector. (See the vehicle wire chart reference for wire colors)

STEP 4

- Plug the aftermarket radio harnesses into the aftermarket radio.
- Plug the Data cable to the data port of the aftermarket radio.
- Insert the Audio cable into the iDatalink 3.5 mm audio jack of the aftermarket radio.

STEP 5

- Connect all the harnesses to the Maestro RR module then proceed to module setup.

The module is now ready to be used.

Insert the aftermarket radio in the dashboard housing and test all the functionalities.

Reassemble the dashboard carefully.

AMPLIFIER ONLY

DETERMINE IF YOU SHOULD USE RCA'S OR LEVEL MATCHING CIRCUITS

- If your vehicle is equipped with a factory amplifier you can connect the RCA wiring to the low level outputs of your aftermarket radio, or connect the level matching circuits to the speaker outputs of the aftermarket radio.
- If your aftermarket radio does not have low level outputs, has only a single RCA output, or the RCA output level is 2 volts or less then it is recommended to connect the level matching circuit to the speaker outputs. If the volume does not go loud enough using the RCA connections, the level matching circuits can be used.
- The internal amplifier in some radios is not compatible with the level matching circuit. In these cases, there will be floor noise (hissing or buzzing at low levels) when the level matching circuit is connected. Change to the RCA connections to eliminate this noise.

TROUBLESHOOTING TIPS:

- To reset the module back its factory settings, turn the key to the OFF position then disconnect all connectors from the module. Press and hold the module's programming button and connect all the connectors back to the module. Wait, the module's LED will flash RED rapidly (this may take up to 10 seconds). Release the programming button. Wait, the LED will turn solid GREEN for 2 seconds.
- For technical assistance call 1-866-427-2999 or e-mail "support@idatalink.com". Visit us at "maestro.idatalink.com/support" and "www.12voltdata.com/forum/"

WIRING DIAGRAM *with an Amplifier*



WIRING DIAGRAM *without an Amplifier*



VEHICLE WIRE REFERENCE CHART

Wire Description	Connector Name	Connector Color	Connector Type	Position	Wire Color	Polarity	Wire Location
CanH	OBDII	~	16 pin	06	Tan/Black	(Data)	OBDII connector, under driver side dash
CanL	OBDII	~	16 pin	14	Tan	(Data)	OBDII connector, under driver side dash

RADIO WIRE REFERENCE CHART

Wire Description	Polarity	Wire Color on Maestro T-Harness	Wire Color on Alpine cable	Wire Color on Kenwood cable	Wire Color on Pioneer cable
Illumination	(+)	Orange	N/A	Orange/White	Orange/White
Reverse Light	(+)	Purple/White	Orange/White	Purple/White	Purple/White
E-Brake	(-)	Lt Green	Yellow/Blue	Lt Green	Lt Green
Foot Brake	(+)	Yellow/Black	Yellow/Black	N/A	N/A
VSS (vehicle speed sensor)	(DATA)	Pink	Green/White	N/A	Pink



INSTALL GUIDE CHEVROLET MONTE CARLO 2006-2007

RETAINS STEERING WHEEL CONTROLS, ONSTAR, BLUETOOTH, XM SATELLITE AND MORE!



PRODUCTS REQUIRED

iDatalink Maestro RR Radio Replacement Interface
iDatalink Maestro GM5+ Installation Harness

OPTIONAL ACCESSORIES

None

PROGRAMMED FIRMWARE

ADS-RR(SR)-GMS05-DS

NOTICE: Automotive Data Solutions Inc. (ADS) recommends having this installation performed by a certified technician. Logos and trademarks used here in are the properties of their respective owners.

WELCOME

Congratulations on the purchase of your iDatalink Maestro RR Radio replacement solution. You are now a few simple steps away from enjoying your new car radio with enhanced features.

Before starting your installation, please ensure that your iDatalink Maestro module is programmed with the correct firmware for your vehicle and that you carefully review the install guide.

Please note that Maestro RR will only retain functionalities that were originally available in the vehicle.

NEED HELP?

 **1 866 427-2999**

 support@idatalink.com

 maestro.idatalink.com/support
www.12voltdata.com/forum

TABLE OF CONTENTS

Before Installing	3
Installation Instructions	4
Wiring Diagram with an Amplifier	5
Wiring Diagram without an Amplifier	6
Vehicle Wire Reference Chart	7
Radio Wire Reference Chart	8

BEFORE INSTALLING

STEP 1

DETERMINE IF YOUR VEHICLE IS EQUIPPED WITH A FACTORY AMPLIFIER:

METHOD 1: Look for the following logos in the vehicle. They are usually on the speaker covers or on the radio unit. If you find any of the following logos Bose, Pioneer or Monsoon, you have a factory amplifier.

BOSE

Pioneer

MONSOON

METHOD 2: Look for the following sticker in the glove box. This sticker will indicate all the Regular Production Option (RPO) codes. If you find any of the following codes UQA, UQS or UQG, you have a factory amplifier.

SERVICE PARTS IDENTIFICATION										DO NOT REMOVE		
2GCEK19N031344764					143 5 FXWH2Q			CKI5753				
AGI	AG2	AJ1	AL0	AM7	AN3	AU0	AU3	A31	B30	B4U		
B58	B81	B82	CJ3	C49	C7H	DF5	DK7	DL3	DT4	D07		
EVA	E63	FF8	FF9	GT5	G80	JC4	KC4	KNP	KUP	K34		
K47	K68	LQ9	M32	NCI	NEI	NP3	NP5	OSC	P30	QSS		
R4Y	R9U	R9Z	SAF	SLM	TRB	UC6	UK3	UQA	U2K	UFI		
UF3	UK3	VR4	VTV	VXS	V73	XSS	X88	YD6	YD6	YE9		
YSS	ZGC	ZYI	Z60	Z82	ISS	ISZ	4IU	6YT	691	692		
7YT												
BC/CC	U	8555				692						

STEP 2

IF YOUR VEHICLE IS EQUIPPED WITH A FACTORY AMPLIFIER:

Follow the installation instructions and complete the installation as shown in the wiring diagram **with an amplifier** and read the "AMPLIFIER ONLY" note to determine if you should use rca's or level matching circuits.

IF YOUR VEHICLE NOT IS EQUIPPED WITH A FACTORY AMPLIFIER:

Follow the installation instructions and complete the installation as shown in the wiring diagram **without an amplifier**.

INSTALLATION INSTRUCTIONS

STEP 1

- Unbox the aftermarket radio and locate its main harness.
- Connect the wires shown on the next page from aftermarket radio main harness to the GM5+ T-harness and match the wire functions.

STEP 2

- Connect the factory harness to the GM5+ T-harness.

STEP 3

- Access the OBDII connector located under the driver side dashboard.
- Connect the BROWN /RED wire of the GM5+ T-harness to the wire located at pin 6 of the OBDII connector. (See the vehicle wire chart reference for wire colors)
- Connect the BROWN /YELLOW wire of the GM5+ T-harness to the wire located at pin 14 of the OBDII connector. (See the vehicle wire chart reference for wire colors)

STEP 4

- Plug the aftermarket radio harnesses into the aftermarket radio.
- Plug the Data cable to the data port of the aftermarket radio.
- Insert the Audio cable into the iDataLink 3.5 mm audio jack of the aftermarket radio.

STEP 5

- Connect all the harnesses to the Maestro RR module then proceed to module setup.

The module is now ready to be used.

Insert the aftermarket radio in the dashboard housing and test all the functionalities.

Reassemble the dashboard carefully.

AMPLIFIER ONLY

DETERMINE IF YOU SHOULD USE RCA'S OR LEVEL MATCHING CIRCUITS

- If your vehicle is equipped with a factory amplifier you can connect the RCA wiring to the low level outputs of your aftermarket radio, or connect the level matching circuits to the speaker outputs of the aftermarket radio.
- If your aftermarket radio does not have low level outputs, has only a single RCA output, or the RCA output level is 2 volts or less then it is recommended to connect the level matching circuit to the speaker outputs. If the volume does not go loud enough using the RCA connections, the level matching circuits can be used.
- The internal amplifier in some radios is not compatible with the level matching circuit. In these cases, there will be floor noise (hissing or buzzing at low levels) when the level matching circuit is connected. Change to the RCA connections to eliminate this noise.

TROUBLESHOOTING TIPS:

- To reset the module back its factory settings, turn the key to the OFF position then disconnect all connectors from the module. Press and hold the module's programming button and connect all the connectors back to the module. Wait, the module's LED will flash RED rapidly (this may take up to 10 seconds). Release the programming button. Wait, the LED will turn solid GREEN for 2 seconds.
- For technical assistance call 1-866-427-2999 or e-mail "support@idatalink.com". Visit us at "maestro.idatalink.com/support" and "www.12voltdata.com/forum/"

WIRING DIAGRAM *with an Amplifier*



WIRING DIAGRAM *without an Amplifier*



VEHICLE WIRE REFERENCE CHART

Wire Description	Connector Name	Connector Color	Connector Type	Position	Wire Color	Polarity	Wire Location
CanH	OBDII	~	16 pin	06	Tan/Black	(Data)	OBDII connector, under driver side dash
CanL	OBDII	~	16 pin	14	Tan	(Data)	OBDII connector, under driver side dash

RADIO WIRE REFERENCE CHART

Wire Description	Polarity	Wire Color on Maestro T-Harness	Wire Color on Alpine cable	Wire Color on Kenwood cable	Wire Color on Pioneer cable
Illumination	(+)	Orange	N/A	Orange/White	Orange/White
Reverse Light	(+)	Purple/White	Orange/White	Purple/White	Purple/White
E-Brake	(-)	Lt Green	Yellow/Blue	Lt Green	Lt Green
Foot Brake	(+)	Yellow/Black	Yellow/Black	N/A	N/A
VSS (vehicle speed sensor)	(DATA)	Pink	Green/White	N/A	Pink



INSTALL GUIDE CHEVROLET SILVERADO 1500 2007-2011

RETAINS STEERING WHEEL CONTROLS, ONSTAR, BLUETOOTH, XM SATELLITE AND MORE!



PRODUCTS REQUIRED

iDatalink Maestro RR Radio Replacement Interface
iDatalink Maestro GM5+ Installation Harness

OPTIONAL ACCESSORIES

None

PROGRAMMED FIRMWARE

ADS-RR(SR)-GMS05-DS

NOTICE: Automotive Data Solutions Inc. (ADS) recommends having this installation performed by a certified technician. Logos and trademarks used here in are the properties of their respective owners.

WELCOME

Congratulations on the purchase of your iDatalink Maestro RR Radio replacement solution. You are now a few simple steps away from enjoying your new car radio with enhanced features.

Before starting your installation, please ensure that your iDatalink Maestro module is programmed with the correct firmware for your vehicle and that you carefully review the install guide.

Please note that Maestro RR will only retain functionalities that were originally available in the vehicle.

NEED HELP?

 **1 866 427-2999**

 support@idatalink.com

 maestro.idatalink.com/support
www.12voltdata.com/forum

TABLE OF CONTENTS

Before Installing	3
Installation Instructions	4
Wiring Diagram with an Amplifier	5
Wiring Diagram without an Amplifier	6
Vehicle Wire Reference Chart	7
Radio Wire Reference Chart	8

BEFORE INSTALLING

STEP 1

DETERMINE IF YOUR VEHICLE IS EQUIPPED WITH A FACTORY AMPLIFIER:

METHOD 1: Look for the following logos in the vehicle. They are usually on the speaker covers or on the radio unit. If you find any of the following logos Bose, Pioneer or Monsoon, you have a factory amplifier.



METHOD 2: Look for the following sticker in the glove box. This sticker will indicate all the Regular Production Option (RPO) codes. If you find any of the following codes UQA, UQS or UQG, you have a factory amplifier.

SERVICE PARTS IDENTIFICATION												DO NOT REMOVE	
2GCEK19N031344764						143 5 FXWH2Q			CKI5753				
AGI	AG2	AJ1	AL0	AM7	AN3	AU0	AU3	A31	B30	B4U			
B58	B81	B82	CJ3	C49	C7H	DF5	DK7	DL3	DT4	D07			
EVA	E63	FF8	FF9	GT5	G80	JC4	KC4	KNP	KUP	K34			
K47	K68	LQ9	M32	NCI	NEI	NP3	NP5	QCC	P30	QSS			
R4Y	R9U	R9Z	SAF	SLM	TRB	UC6	UK3	UQA	U2K	UFI			
UF3	UK3	VR4	VTV	VXS	V73	XSS	X88	YD6	YD6	YE9			
YSS	ZGC	ZYI	Z60	Z82	ISS	ISZ	4IU	6YT	691	692			
7YT													
BC/CC	U	8555				692							

STEP 2

IF YOUR VEHICLE IS EQUIPPED WITH A FACTORY AMPLIFIER:

Follow the installation instructions and complete the installation as shown in the wiring diagram **with an amplifier** and read the "AMPLIFIER ONLY" note to determine if you should use rca's or level matching circuits.

IF YOUR VEHICLE NOT IS EQUIPPED WITH A FACTORY AMPLIFIER:

Follow the installation instructions and complete the installation as shown in the wiring diagram **without an amplifier**.

INSTALLATION INSTRUCTIONS

STEP 1

- Unbox the aftermarket radio and locate its main harness.
- Connect the wires shown on the next page from aftermarket radio main harness to the GM5+ T-harness and match the wire functions.

STEP 2

- Connect the factory harness to the GM5+ T-harness.

STEP 3

- Access the OBDII connector located under the driver side dashboard.
- Connect the BROWN /RED wire of the GM5+ T-harness to the wire located at pin 6 of the OBDII connector. (See the vehicle wire chart reference for wire colors)
- Connect the BROWN /YELLOW wire of the GM5+ T-harness to the wire located at pin 14 of the OBDII connector. (See the vehicle wire chart reference for wire colors)

STEP 4

- Plug the aftermarket radio harnesses into the aftermarket radio.
- Plug the Data cable to the data port of the aftermarket radio.
- Insert the Audio cable into the iDatalink 3.5 mm audio jack of the aftermarket radio.

STEP 5

- Connect all the harnesses to the Maestro RR module then proceed to module setup.

The module is now ready to be used.

Insert the aftermarket radio in the dashboard housing and test all the functionalities.

Reassemble the dashboard carefully.

AMPLIFIER ONLY

DETERMINE IF YOU SHOULD USE RCA'S OR LEVEL MATCHING CIRCUITS

- If your vehicle is equipped with a factory amplifier you can connect the RCA wiring to the low level outputs of your aftermarket radio, or connect the level matching circuits to the speaker outputs of the aftermarket radio.
- If your aftermarket radio does not have low level outputs, has only a single RCA output, or the RCA output level is 2 volts or less then it is recommended to connect the level matching circuit to the speaker outputs. If the volume does not go loud enough using the RCA connections, the level matching circuits can be used.
- The internal amplifier in some radios is not compatible with the level matching circuit. In these cases, there will be floor noise (hissing or buzzing at low levels) when the level matching circuit is connected. Change to the RCA connections to eliminate this noise.

TROUBLESHOOTING TIPS:

- To reset the module back its factory settings, turn the key to the OFF position then disconnect all connectors from the module. Press and hold the module's programming button and connect all the connectors back to the module. Wait, the module's LED will flash RED rapidly (this may take up to 10 seconds). Release the programming button. Wait, the LED will turn solid GREEN for 2 seconds.
- For technical assistance call 1-866-427-2999 or e-mail "support@idatalink.com". Visit us at "maestro.idatalink.com/support" and "www.12voltdata.com/forum/"

WIRING DIAGRAM *with an Amplifier*



WIRING DIAGRAM *without an Amplifier*



VEHICLE WIRE REFERENCE CHART

Wire Description	Connector Name	Connector Color	Connector Type	Position	Wire Color	Polarity	Wire Location
CanH	OBDII	~	16 pin	06	Tan/Black	(Data)	OBDII connector, under driver side dash
CanL	OBDII	~	16 pin	14	Tan	(Data)	OBDII connector, under driver side dash

RADIO WIRE REFERENCE CHART

Wire Description	Polarity	Wire Color on Maestro T-Harness	Wire Color on Alpine cable	Wire Color on Kenwood cable	Wire Color on Pioneer cable
Illumination	(+)	Orange	N/A	Orange/White	Orange/White
Reverse Light	(+)	Purple/White	Orange/White	Purple/White	Purple/White
E-Brake	(-)	Lt Green	Yellow/Blue	Lt Green	Lt Green
Foot Brake	(+)	Yellow/Black	Yellow/Black	N/A	N/A
VSS (vehicle speed sensor)	(DATA)	Pink	Green/White	N/A	Pink



INSTALL GUIDE

CHEVROLET SILVERADO 1500

WITHOUT NAV 2012-2013

RETAINS STEERING WHEEL CONTROLS, ONSTAR, BLUETOOTH, XM SATELLITE AND MORE!



PRODUCTS REQUIRED

iDatalink Maestro RR Radio Replacement Interface
iDatalink Maestro GM5+ Installation Harness

OPTIONAL ACCESSORIES

None

PROGRAMMED FIRMWARE

ADS-RR(SR)-GMS05-DS

NOTICE: Automotive Data Solutions Inc. (ADS) recommends having this installation performed by a certified technician. Logos and trademarks used here in are the properties of their respective owners.

WELCOME

Congratulations on the purchase of your iDatalink Maestro RR Radio replacement solution. You are now a few simple steps away from enjoying your new car radio with enhanced features.

Before starting your installation, please ensure that your iDatalink Maestro module is programmed with the correct firmware for your vehicle and that you carefully review the install guide.

Please note that Maestro RR will only retain functionalities that were originally available in the vehicle.

NEED HELP?

 **1 866 427-2999**

 **support@idatalink.com**

 **maestro.idatalink.com/support
www.12voltdata.com/forum**

TABLE OF CONTENTS

Before Installing	3
Installation Instructions	4
Wiring Diagram with an Amplifier	5
Wiring Diagram without an Amplifier	6
Vehicle Wire Reference Chart	7
Radio Wire Reference Chart	8

BEFORE INSTALLING

STEP 1

DETERMINE IF YOUR VEHICLE IS EQUIPPED WITH A FACTORY AMPLIFIER:

METHOD 1: Look for the following logos in the vehicle. They are usually on the speaker covers or on the radio unit. If you find any of the following logos Bose, Pioneer or Monsoon, you have a factory amplifier.



METHOD 2: Look for the following sticker in the glove box. This sticker will indicate all the Regular Production Option (RPO) codes. If you find any of the following codes UQA, UQS or UQG, you have a factory amplifier.

SERVICE PARTS IDENTIFICATION												DO NOT REMOVE	
2GCEK19N031344764						143 5 FXWH2Q			CKI5753				
AGI	AG2	AJ1	AL0	AM7	AN3	AU0	AU3	A31	B30	B4U			
B58	B81	B82	CJ3	C49	C7H	DF5	DK7	DL3	DT4	D07			
EVA	E63	FF8	FF9	GT5	G80	JC4	KC4	KNP	KUP	K34			
K47	K68	LQ9	M32	NCI	NEI	NP3	NP5	QCC	P30	QSS			
R4Y	R9U	R9Z	SAF	SLM	TRB	UC6	UK3	UQA	U2K	UFI			
UF3	UK3	VR4	VTV	VXS	V73	XSS	X88	YD6	YE9				
YSS	ZGC	ZYI	Z60	Z82	ISS	ISZ	4IU	6YT	691	692			
7YT													
BC/CC	U	8555				692							

STEP 2

IF YOUR VEHICLE IS EQUIPPED WITH A FACTORY AMPLIFIER:

Follow the installation instructions and complete the installation as shown in the wiring diagram **with an amplifier** and read the "AMPLIFIER ONLY" note to determine if you should use rca's or level matching circuits.

IF YOUR VEHICLE NOT IS EQUIPPED WITH A FACTORY AMPLIFIER:

Follow the installation instructions and complete the installation as shown in the wiring diagram **without an amplifier**.

INSTALLATION INSTRUCTIONS

STEP 1

- Unbox the aftermarket radio and locate its main harness.
- Connect the wires shown on the next page from aftermarket radio main harness to the GM5+ T-harness and match the wire functions.

STEP 2

- Connect the factory harness to the GM5+ T-harness.

STEP 3

- Access the OBDII connector located under the driver side dashboard.
- Connect the BROWN /RED wire of the GM5+ T-harness to the wire located at pin 6 of the OBDII connector. (See the vehicle wire chart reference for wire colors)
- Connect the BROWN /YELLOW wire of the GM5+ T-harness to the wire located at pin 14 of the OBDII connector. (See the vehicle wire chart reference for wire colors)

STEP 4

- Plug the aftermarket radio harnesses into the aftermarket radio.
- Plug the Data cable to the data port of the aftermarket radio.
- Insert the Audio cable into the iDatalink 3.5 mm audio jack of the aftermarket radio.

STEP 5

- Connect all the harnesses to the Maestro RR module then proceed to module setup.

The module is now ready to be used.

Insert the aftermarket radio in the dashboard housing and test all the functionalities.

Reassemble the dashboard carefully.

AMPLIFIER ONLY

DETERMINE IF YOU SHOULD USE RCA'S OR LEVEL MATCHING CIRCUITS

- If your vehicle is equipped with a factory amplifier you can connect the RCA wiring to the low level outputs of your aftermarket radio, or connect the level matching circuits to the speaker outputs of the aftermarket radio.
- If your aftermarket radio does not have low level outputs, has only a single RCA output, or the RCA output level is 2 volts or less then it is recommended to connect the level matching circuit to the speaker outputs. If the volume does not go loud enough using the RCA connections, the level matching circuits can be used.
- The internal amplifier in some radios is not compatible with the level matching circuit. In these cases, there will be floor noise (hissing or buzzing at low levels) when the level matching circuit is connected. Change to the RCA connections to eliminate this noise.

TROUBLESHOOTING TIPS:

- To reset the module back its factory settings, turn the key to the OFF position then disconnect all connectors from the module. Press and hold the module's programming button and connect all the connectors back to the module. Wait, the module's LED will flash RED rapidly (this may take up to 10 seconds). Release the programming button. Wait, the LED will turn solid GREEN for 2 seconds.
- For technical assistance call 1-866-427-2999 or e-mail "support@idatalink.com". Visit us at "maestro.idatalink.com/support" and "www.12voltdata.com/forum/"

WIRING DIAGRAM *with an Amplifier*



WIRING DIAGRAM *without an Amplifier*



VEHICLE WIRE REFERENCE CHART

Wire Description	Connector Name	Connector Color	Connector Type	Position	Wire Color	Polarity	Wire Location
CanH	OBDII	~	16 pin	06	Tan/Black	(Data)	OBDII connector, under driver side dash
CanL	OBDII	~	16 pin	14	Tan	(Data)	OBDII connector, under driver side dash

RADIO WIRE REFERENCE CHART

Wire Description	Polarity	Wire Color on Maestro T-Harness	Wire Color on Alpine cable	Wire Color on Kenwood cable	Wire Color on Pioneer cable
Illumination	(+)	Orange	N/A	Orange/White	Orange/White
Reverse Light	(+)	Purple/White	Orange/White	Purple/White	Purple/White
E-Brake	(-)	Lt Green	Yellow/Blue	Lt Green	Lt Green
Foot Brake	(+)	Yellow/Black	Yellow/Black	N/A	N/A
VSS (vehicle speed sensor)	(DATA)	Pink	Green/White	N/A	Pink



INSTALL GUIDE CHEVROLET SILVERADO 2500 & 3500 2007-2011

RETAINS STEERING WHEEL CONTROLS, ONSTAR, BLUETOOTH, XM SATELLITE AND MORE!



PRODUCTS REQUIRED

iDatalink Maestro RR Radio Replacement Interface
iDatalink Maestro GM5+ Installation Harness

OPTIONAL ACCESSORIES

None

PROGRAMMED FIRMWARE

ADS-RR(SR)-GMS05-DS

NOTICE: Automotive Data Solutions Inc. (ADS) recommends having this installation performed by a certified technician. Logos and trademarks used here in are the properties of their respective owners.

WELCOME

Congratulations on the purchase of your iDatalink Maestro RR Radio replacement solution. You are now a few simple steps away from enjoying your new car radio with enhanced features.

Before starting your installation, please ensure that your iDatalink Maestro module is programmed with the correct firmware for your vehicle and that you carefully review the install guide.

Please note that Maestro RR will only retain functionalities that were originally available in the vehicle.

NEED HELP?

 **1 866 427-2999**

 support@idatalink.com

 maestro.idatalink.com/support
www.12voltdata.com/forum

TABLE OF CONTENTS

Before Installing	3
Installation Instructions	4
Wiring Diagram with an Amplifier	5
Wiring Diagram without an Amplifier	6
Vehicle Wire Reference Chart	7
Radio Wire Reference Chart	8

BEFORE INSTALLING

STEP 1

DETERMINE IF YOUR VEHICLE IS EQUIPPED WITH A FACTORY AMPLIFIER:

METHOD 1: Look for the following logos in the vehicle. They are usually on the speaker covers or on the radio unit. If you find any of the following logos Bose, Pioneer or Monsoon, you have a factory amplifier.



METHOD 2: Look for the following sticker in the glove box. This sticker will indicate all the Regular Production Option (RPO) codes. If you find any of the following codes UQA, UQS or UQG, you have a factory amplifier.

SERVICE PARTS IDENTIFICATION												DO NOT REMOVE	
2GCEK19N031344764						143 5 FXWH2Q			CKI5753				
AGI	AG2	AJ1	AL0	AM7	AN3	AU0	AU3	A31	B30	B4U			
B58	B81	B82	CJ3	C49	C7H	DF5	DK7	DL3	DT4	D07			
EVA	E63	FF8	FF9	GT5	G80	JC4	KC4	KNP	KUP	K34			
K47	K68	LQ9	M32	NCI	NEI	NP3	NP5	QCC	P30	QSS			
R4Y	R9U	R9Z	SAF	SLM	TRB	UC6	UK3	UQA	U2K	UFI			
UF3	UK3	VR4	VTV	VXS	V73	XSS	X88	YD6	YE9				
YSS	ZGC	ZYI	Z60	Z82	ISS	ISZ	4IU	6YT	691	692			
7YT													
BC/CC		U	8555			692							

STEP 2

IF YOUR VEHICLE IS EQUIPPED WITH A FACTORY AMPLIFIER:

Follow the installation instructions and complete the installation as shown in the wiring diagram **with an amplifier** and read the "AMPLIFIER ONLY" note to determine if you should use rca's or level matching circuits.

IF YOUR VEHICLE NOT IS EQUIPPED WITH A FACTORY AMPLIFIER:

Follow the installation instructions and complete the installation as shown in the wiring diagram **without an amplifier**.

INSTALLATION INSTRUCTIONS

STEP 1

- Unbox the aftermarket radio and locate its main harness.
- Connect the wires shown on the next page from aftermarket radio main harness to the GM5+ T-harness and match the wire functions.

STEP 2

- Connect the factory harness to the GM5+ T-harness.

STEP 3

- Access the OBDII connector located under the driver side dashboard.
- Connect the BROWN /RED wire of the GM5+ T-harness to the wire located at pin 6 of the OBDII connector. (See the vehicle wire chart reference for wire colors)
- Connect the BROWN /YELLOW wire of the GM5+ T-harness to the wire located at pin 14 of the OBDII connector. (See the vehicle wire chart reference for wire colors)

STEP 4

- Plug the aftermarket radio harnesses into the aftermarket radio.
- Plug the Data cable to the data port of the aftermarket radio.
- Insert the Audio cable into the iDatalink 3.5 mm audio jack of the aftermarket radio.

STEP 5

- Connect all the harnesses to the Maestro RR module then proceed to module setup.

The module is now ready to be used.

Insert the aftermarket radio in the dashboard housing and test all the functionalities.

Reassemble the dashboard carefully.

AMPLIFIER ONLY

DETERMINE IF YOU SHOULD USE RCA'S OR LEVEL MATCHING CIRCUITS

- If your vehicle is equipped with a factory amplifier you can connect the RCA wiring to the low level outputs of your aftermarket radio, or connect the level matching circuits to the speaker outputs of the aftermarket radio.
- If your aftermarket radio does not have low level outputs, has only a single RCA output, or the RCA output level is 2 volts or less then it is recommended to connect the level matching circuit to the speaker outputs. If the volume does not go loud enough using the RCA connections, the level matching circuits can be used.
- The internal amplifier in some radios is not compatible with the level matching circuit. In these cases, there will be floor noise (hissing or buzzing at low levels) when the level matching circuit is connected. Change to the RCA connections to eliminate this noise.

TROUBLESHOOTING TIPS:

- To reset the module back its factory settings, turn the key to the OFF position then disconnect all connectors from the module. Press and hold the module's programming button and connect all the connectors back to the module. Wait, the module's LED will flash RED rapidly (this may take up to 10 seconds). Release the programming button. Wait, the LED will turn solid GREEN for 2 seconds.
- For technical assistance call 1-866-427-2999 or e-mail "support@idatalink.com". Visit us at "maestro.idatalink.com/support" and "www.12voltdata.com/forum/"

WIRING DIAGRAM *with an Amplifier*



WIRING DIAGRAM *without an Amplifier*



VEHICLE WIRE REFERENCE CHART

Wire Description	Connector Name	Connector Color	Connector Type	Position	Wire Color	Polarity	Wire Location
CanH	OBDII	~	16 pin	06	Tan/Black	(Data)	OBDII connector, under driver side dash
CanL	OBDII	~	16 pin	14	Tan	(Data)	OBDII connector, under driver side dash

RADIO WIRE REFERENCE CHART

Wire Description	Polarity	Wire Color on Maestro T-Harness	Wire Color on Alpine cable	Wire Color on Kenwood cable	Wire Color on Pioneer cable
Illumination	(+)	Orange	N/A	Orange/White	Orange/White
Reverse Light	(+)	Purple/White	Orange/White	Purple/White	Purple/White
E-Brake	(-)	Lt Green	Yellow/Blue	Lt Green	Lt Green
Foot Brake	(+)	Yellow/Black	Yellow/Black	N/A	N/A
VSS (vehicle speed sensor)	(DATA)	Pink	Green/White	N/A	Pink



INSTALL GUIDE CHEVROLET SILVERADO 2500 & 3500 WITHOUT NAV 2012-2014

RETAINS STEERING WHEEL CONTROLS, ONSTAR, BLUETOOTH, XM SATELLITE AND MORE!



PRODUCTS REQUIRED

iDatalink Maestro RR Radio Replacement Interface
iDatalink Maestro GM5+ Installation Harness

OPTIONAL ACCESSORIES

None

PROGRAMMED FIRMWARE

ADS-RR(SR)-GMS05-DS

NOTICE: Automotive Data Solutions Inc. (ADS) recommends having this installation performed by a certified technician. Logos and trademarks used here in are the properties of their respective owners.

WELCOME

Congratulations on the purchase of your iDatalink Maestro RR Radio replacement solution. You are now a few simple steps away from enjoying your new car radio with enhanced features.

Before starting your installation, please ensure that your iDatalink Maestro module is programmed with the correct firmware for your vehicle and that you carefully review the install guide.

Please note that Maestro RR will only retain functionalities that were originally available in the vehicle.

NEED HELP?

 **1 866 427-2999**

 support@idatalink.com

 maestro.idatalink.com/support
www.12voltdata.com/forum

TABLE OF CONTENTS

Before Installing	3
Installation Instructions	4
Wiring Diagram with an Amplifier	5
Wiring Diagram without an Amplifier	6
Vehicle Wire Reference Chart	7
Radio Wire Reference Chart	8

BEFORE INSTALLING

STEP 1

DETERMINE IF YOUR VEHICLE IS EQUIPPED WITH A FACTORY AMPLIFIER:

METHOD 1: Look for the following logos in the vehicle. They are usually on the speaker covers or on the radio unit. If you find any of the following logos Bose, Pioneer or Monsoon, you have a factory amplifier.



METHOD 2: Look for the following sticker in the glove box. This sticker will indicate all the Regular Production Option (RPO) codes. If you find any of the following codes UQA, UQS or UQG, you have a factory amplifier.

SERVICE PARTS IDENTIFICATION										DO NOT REMOVE		
2GCEK19N031344764				143 5 FXWH2Q				CKI5753				
AGI	AG2	AJ1	AL0	AM7	AN3	AU0	AU3	A31	B30	B4U		
B58	B81	B82	CJ3	C49	C7H	DF5	DK7	DL3	DT4	D07		
EVA	E63	FF8	FF9	GT5	G80	JC4	KC4	KNP	KUP	K34		
K47	K68	LQ9	M32	NCI	NEI	NP3	NP5	QCC	P30	QSS		
R4Y	R9U	R9Z	SAF	SLM	TRB	UC6	UK3	UQA	U2K	UFI		
UF3	UK3	VR4	VTV	VXS	V73	XSS	X88	YD6	YD6	YE9		
YSS	ZGC	ZYI	Z60	Z82	ISS	ISZ	4IU	6YT	691	692		
7YT												
BC/CC	U	8555				692						

STEP 2

IF YOUR VEHICLE IS EQUIPPED WITH A FACTORY AMPLIFIER:

Follow the installation instructions and complete the installation as shown in the wiring diagram **with an amplifier** and read the "AMPLIFIER ONLY" note to determine if you should use rca's or level matching circuits.

IF YOUR VEHICLE NOT IS EQUIPPED WITH A FACTORY AMPLIFIER:

Follow the installation instructions and complete the installation as shown in the wiring diagram **without an amplifier**.

INSTALLATION INSTRUCTIONS

STEP 1

- Unbox the aftermarket radio and locate its main harness.
- Connect the wires shown on the next page from aftermarket radio main harness to the GM5+ T-harness and match the wire functions.

STEP 2

- Connect the factory harness to the GM5+ T-harness.

STEP 3

- Access the OBDII connector located under the driver side dashboard.
- Connect the BROWN /RED wire of the GM5+ T-harness to the wire located at pin 6 of the OBDII connector. (See the vehicle wire chart reference for wire colors)
- Connect the BROWN /YELLOW wire of the GM5+ T-harness to the wire located at pin 14 of the OBDII connector. (See the vehicle wire chart reference for wire colors)

STEP 4

- Plug the aftermarket radio harnesses into the aftermarket radio.
- Plug the Data cable to the data port of the aftermarket radio.
- Insert the Audio cable into the iDatalink 3.5 mm audio jack of the aftermarket radio.

STEP 5

- Connect all the harnesses to the Maestro RR module then proceed to module setup.

The module is now ready to be used.

Insert the aftermarket radio in the dashboard housing and test all the functionalities.

Reassemble the dashboard carefully.

AMPLIFIER ONLY

DETERMINE IF YOU SHOULD USE RCA'S OR LEVEL MATCHING CIRCUITS

- If your vehicle is equipped with a factory amplifier you can connect the RCA wiring to the low level outputs of your aftermarket radio, or connect the level matching circuits to the speaker outputs of the aftermarket radio.
- If your aftermarket radio does not have low level outputs, has only a single RCA output, or the RCA output level is 2 volts or less then it is recommended to connect the level matching circuit to the speaker outputs. If the volume does not go loud enough using the RCA connections, the level matching circuits can be used.
- The internal amplifier in some radios is not compatible with the level matching circuit. In these cases, there will be floor noise (hissing or buzzing at low levels) when the level matching circuit is connected. Change to the RCA connections to eliminate this noise.

TROUBLESHOOTING TIPS:

- To reset the module back its factory settings, turn the key to the OFF position then disconnect all connectors from the module. Press and hold the module's programming button and connect all the connectors back to the module. Wait, the module's LED will flash RED rapidly (this may take up to 10 seconds). Release the programming button. Wait, the LED will turn solid GREEN for 2 seconds.
- For technical assistance call 1-866-427-2999 or e-mail "support@idatalink.com". Visit us at "maestro.idatalink.com/support" and "www.12voltdata.com/forum/"

WIRING DIAGRAM *with an Amplifier*



WIRING DIAGRAM *without an Amplifier*



VEHICLE WIRE REFERENCE CHART

Wire Description	Connector Name	Connector Color	Connector Type	Position	Wire Color	Polarity	Wire Location
CanH	OBDII	~	16 pin	06	Tan/Black	(Data)	OBDII connector, under driver side dash
CanL	OBDII	~	16 pin	14	Tan	(Data)	OBDII connector, under driver side dash

RADIO WIRE REFERENCE CHART

Wire Description	Polarity	Wire Color on Maestro T-Harness	Wire Color on Alpine cable	Wire Color on Kenwood cable	Wire Color on Pioneer cable
Illumination	(+)	Orange	N/A	Orange/White	Orange/White
Reverse Light	(+)	Purple/White	Orange/White	Purple/White	Purple/White
E-Brake	(-)	Lt Green	Yellow/Blue	Lt Green	Lt Green
Foot Brake	(+)	Yellow/Black	Yellow/Black	N/A	N/A
VSS (vehicle speed sensor)	(DATA)	Pink	Green/White	N/A	Pink



INSTALL GUIDE CHEVROLET SUBURBAN 2007-2011

RETAINS STEERING WHEEL CONTROLS, ONSTAR, BLUETOOTH, XM SATELLITE AND MORE!



PRODUCTS REQUIRED

iDatalink Maestro RR Radio Replacement Interface
iDatalink Maestro GM5+ Installation Harness

OPTIONAL ACCESSORIES

None

PROGRAMMED FIRMWARE

ADS-RR(SR)-GMS05-DS

NOTICE: Automotive Data Solutions Inc. (ADS) recommends having this installation performed by a certified technician. Logos and trademarks used here in are the properties of their respective owners.

WELCOME

Congratulations on the purchase of your iDatalink Maestro RR Radio replacement solution. You are now a few simple steps away from enjoying your new car radio with enhanced features.

Before starting your installation, please ensure that your iDatalink Maestro module is programmed with the correct firmware for your vehicle and that you carefully review the install guide.

Please note that Maestro RR will only retain functionalities that were originally available in the vehicle.

NEED HELP?

 **1 866 427-2999**

 support@idatalink.com

 maestro.idatalink.com/support
www.12voltdata.com/forum

TABLE OF CONTENTS

Before Installing	3
Installation Instructions	4
Wiring Diagram with an Amplifier	5
Wiring Diagram without an Amplifier	6
Vehicle Wire Reference Chart	7
Radio Wire Reference Chart	8

BEFORE INSTALLING

STEP 1

DETERMINE IF YOUR VEHICLE IS EQUIPPED WITH A FACTORY AMPLIFIER:

METHOD 1: Look for the following logos in the vehicle. They are usually on the speaker covers or on the radio unit. If you find any of the following logos Bose, Pioneer or Monsoon, you have a factory amplifier.



METHOD 2: Look for the following sticker in the glove box. This sticker will indicate all the Regular Production Option (RPO) codes. If you find any of the following codes UQA, UQS or UQG, you have a factory amplifier.

SERVICE PARTS IDENTIFICATION												DO NOT REMOVE	
2GCEK19N031344764						143 5 FXWH2Q			CKI5753				
AGI	AG2	AJ1	AL0	AM7	AN3	AU0	AU3	A31	B30	B4U			
B58	B81	B82	CJ3	C49	C7H	DF5	DK7	DL3	DT4	D07			
EVA	E63	FF8	FF9	GT5	G80	JC4	KC4	KNP	KUP	K34			
K47	K68	LQ9	M32	NCI	NEI	NP3	NP5	QCC	P30	QSS			
R4Y	R9U	R9Z	SAF	SLM	TRB	UC6	UK3	UQA	U2K	UFI			
UF3	UK3	VR4	VTV	VXS	V73	XSS	X88	YD6	YD6	YE9			
YSS	ZGC	ZYI	Z60	Z82	ISS	ISZ	4IU	6YT	691	692			
7YT													
BC/CC	U	8555				692							

STEP 2

IF YOUR VEHICLE IS EQUIPPED WITH A FACTORY AMPLIFIER:

Follow the installation instructions and complete the installation as shown in the wiring diagram **with an amplifier** and read the "AMPLIFIER ONLY" note to determine if you should use rca's or level matching circuits.

IF YOUR VEHICLE NOT IS EQUIPPED WITH A FACTORY AMPLIFIER:

Follow the installation instructions and complete the installation as shown in the wiring diagram **without an amplifier**.

INSTALLATION INSTRUCTIONS

STEP 1

- Unbox the aftermarket radio and locate its main harness.
- Connect the wires shown on the next page from aftermarket radio main harness to the GM5+ T-harness and match the wire functions.

STEP 2

- Connect the factory harness to the GM5+ T-harness.

STEP 3

- Access the OBDII connector located under the driver side dashboard.
- Connect the BROWN /RED wire of the GM5+ T-harness to the wire located at pin 6 of the OBDII connector. (See the vehicle wire chart reference for wire colors)
- Connect the BROWN /YELLOW wire of the GM5+ T-harness to the wire located at pin 14 of the OBDII connector. (See the vehicle wire chart reference for wire colors)

STEP 4

- Plug the aftermarket radio harnesses into the aftermarket radio.
- Plug the Data cable to the data port of the aftermarket radio.
- Insert the Audio cable into the iDatalink 3.5 mm audio jack of the aftermarket radio.

STEP 5

- Connect all the harnesses to the Maestro RR module then proceed to module setup.

The module is now ready to be used.

Insert the aftermarket radio in the dashboard housing and test all the functionalities.

Reassemble the dashboard carefully.

AMPLIFIER ONLY

DETERMINE IF YOU SHOULD USE RCA'S OR LEVEL MATCHING CIRCUITS

- If your vehicle is equipped with a factory amplifier you can connect the RCA wiring to the low level outputs of your aftermarket radio, or connect the level matching circuits to the speaker outputs of the aftermarket radio.
- If your aftermarket radio does not have low level outputs, has only a single RCA output, or the RCA output level is 2 volts or less then it is recommended to connect the level matching circuit to the speaker outputs. If the volume does not go loud enough using the RCA connections, the level matching circuits can be used.
- The internal amplifier in some radios is not compatible with the level matching circuit. In these cases, there will be floor noise (hissing or buzzing at low levels) when the level matching circuit is connected. Change to the RCA connections to eliminate this noise.

TROUBLESHOOTING TIPS:

- To reset the module back its factory settings, turn the key to the OFF position then disconnect all connectors from the module. Press and hold the module's programming button and connect all the connectors back to the module. Wait, the module's LED will flash RED rapidly (this may take up to 10 seconds). Release the programming button. Wait, the LED will turn solid GREEN for 2 seconds.
- For technical assistance call 1-866-427-2999 or e-mail "support@idatalink.com". Visit us at "maestro.idatalink.com/support" and "www.12voltdata.com/forum/"

WIRING DIAGRAM *with an Amplifier*



WIRING DIAGRAM *without an Amplifier*

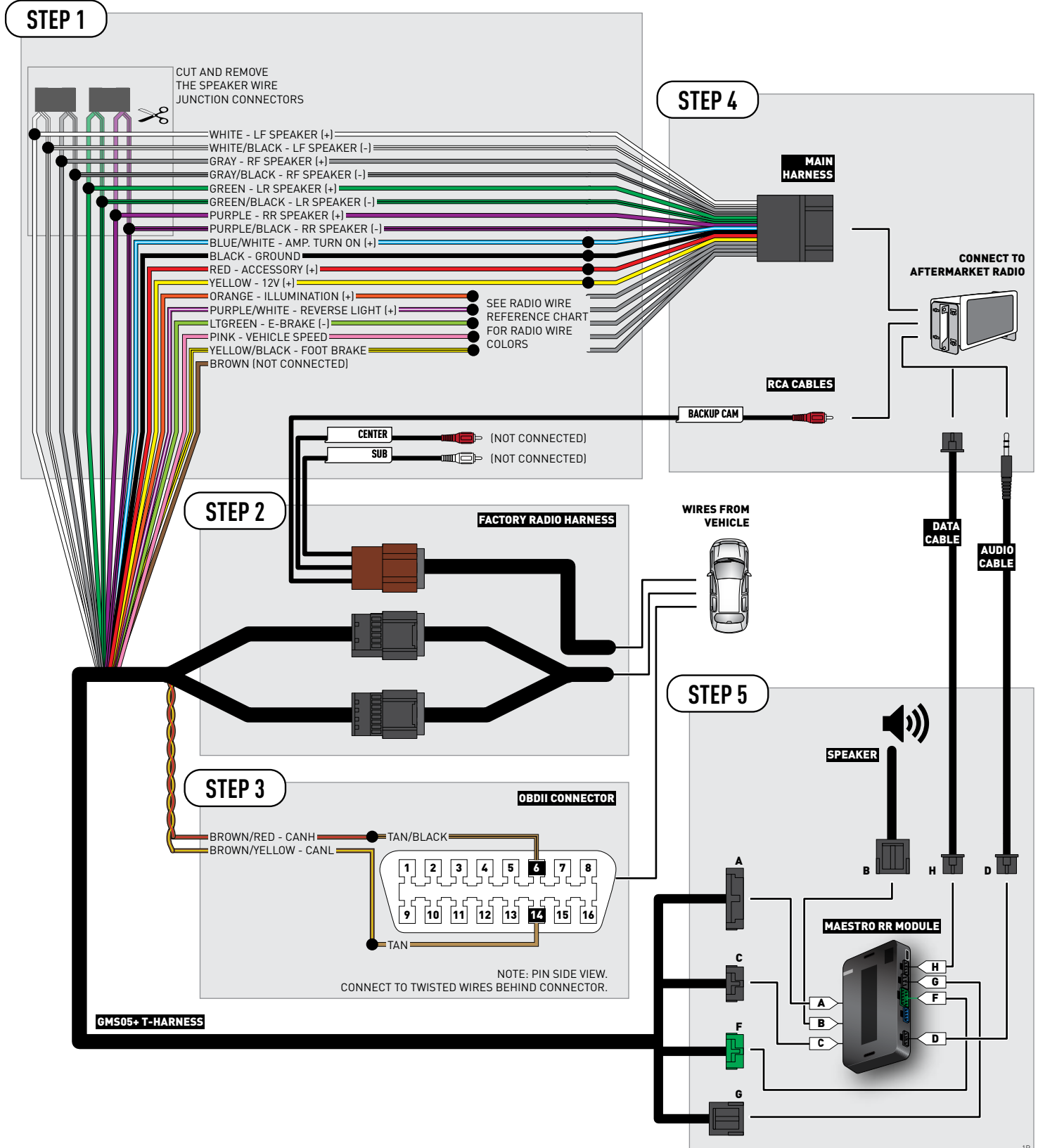

VEHICLE WIRE REFERENCE CHART

Wire Description	Connector Name	Connector Color	Connector Type	Position	Wire Color	Polarity	Wire Location
CanH	OBDII	~	16 pin	06	Tan/Black	(Data)	OBDII connector, under driver side dash
CanL	OBDII	~	16 pin	14	Tan	(Data)	OBDII connector, under driver side dash

RADIO WIRE REFERENCE CHART

Wire Description	Polarity	Wire Color on Maestro T-Harness	Wire Color on Alpine cable	Wire Color on Kenwood cable	Wire Color on Pioneer cable
Illumination	(+)	Orange	N/A	Orange/White	Orange/White
Reverse Light	(+)	Purple/White	Orange/White	Purple/White	Purple/White
E-Brake	(-)	Lt Green	Yellow/Blue	Lt Green	Lt Green
Foot Brake	(+)	Yellow/Black	Yellow/Black	N/A	N/A
VSS (vehicle speed sensor)	(DATA)	Pink	Green/White	N/A	Pink



INSTALL GUIDE CHEVROLET SUBURBAN WITHOUT NAV 2012-2014

RETAINS STEERING WHEEL CONTROLS, ONSTAR, BLUETOOTH, XM SATELLITE AND MORE!



PRODUCTS REQUIRED

iDatalink Maestro RR Radio Replacement Interface
iDatalink Maestro GM5+ Installation Harness

OPTIONAL ACCESSORIES

None

PROGRAMMED FIRMWARE

ADS-RR(SR)-GMS05-DS

NOTICE: Automotive Data Solutions Inc. (ADS) recommends having this installation performed by a certified technician. Logos and trademarks used here in are the properties of their respective owners.

WELCOME

Congratulations on the purchase of your iDatalink Maestro RR Radio replacement solution. You are now a few simple steps away from enjoying your new car radio with enhanced features.

Before starting your installation, please ensure that your iDatalink Maestro module is programmed with the correct firmware for your vehicle and that you carefully review the install guide.

Please note that Maestro RR will only retain functionalities that were originally available in the vehicle.

NEED HELP?

 **1 866 427-2999**

 support@idatalink.com

 maestro.idatalink.com/support
www.12voltdata.com/forum

TABLE OF CONTENTS

Before Installing	3
Installation Instructions	4
Wiring Diagram with an Amplifier	5
Wiring Diagram without an Amplifier	6
Vehicle Wire Reference Chart	7
Radio Wire Reference Chart	8

BEFORE INSTALLING

STEP 1

DETERMINE IF YOUR VEHICLE IS EQUIPPED WITH A FACTORY AMPLIFIER:

METHOD 1: Look for the following logos in the vehicle. They are usually on the speaker covers or on the radio unit. If you find any of the following logos Bose, Pioneer or Monsoon, you have a factory amplifier.



METHOD 2: Look for the following sticker in the glove box. This sticker will indicate all the Regular Production Option (RPO) codes. If you find any of the following codes UQA, UQS or UQG, you have a factory amplifier.

SERVICE PARTS IDENTIFICATION												DO NOT REMOVE	
2GCEK19N031344764						143 5 FXWH2Q			CKI5753				
AGI	AG2	AJ1	AL0	AM7	AN3	AU0	AU3	A31	B30	B4U			
B58	B81	B82	CJ3	C49	C7H	DF5	DK7	DL3	DT4	D07			
EVA	E63	FF8	FF9	GT5	G80	JC4	KC4	KNP	KUP	K34			
K47	K68	LQ9	M32	NCI	NEI	NP3	NP5	QCC	P30	QSS			
R4Y	R9U	R9Z	SAF	SLM	TRB	UC6	UK3	UQA	U2K	UFI			
UF3	UK3	VR4	VTV	VXS	V73	XSS	X88	YD6	YE9				
YSS	ZGC	ZYI	Z60	Z82	ISS	ISZ	4IU	6YT	691	692			
7YT													
BC/CC	U	8555				692							

STEP 2

IF YOUR VEHICLE IS EQUIPPED WITH A FACTORY AMPLIFIER:

Follow the installation instructions and complete the installation as shown in the wiring diagram **with an amplifier** and read the "AMPLIFIER ONLY" note to determine if you should use rca's or level matching circuits.

IF YOUR VEHICLE NOT IS EQUIPPED WITH A FACTORY AMPLIFIER:

Follow the installation instructions and complete the installation as shown in the wiring diagram **without an amplifier**.

INSTALLATION INSTRUCTIONS

STEP 1

- Unbox the aftermarket radio and locate its main harness.
- Connect the wires shown on the next page from aftermarket radio main harness to the GM5+ T-harness and match the wire functions.

STEP 2

- Connect the factory harness to the GM5+ T-harness.

STEP 3

- Access the OBDII connector located under the driver side dashboard.
- Connect the BROWN /RED wire of the GM5+ T-harness to the wire located at pin 6 of the OBDII connector. (See the vehicle wire chart reference for wire colors)
- Connect the BROWN /YELLOW wire of the GM5+ T-harness to the wire located at pin 14 of the OBDII connector. (See the vehicle wire chart reference for wire colors)

STEP 4

- Plug the aftermarket radio harnesses into the aftermarket radio.
- Plug the Data cable to the data port of the aftermarket radio.
- Insert the Audio cable into the iDataLink 3.5 mm audio jack of the aftermarket radio.

STEP 5

- Connect all the harnesses to the Maestro RR module then proceed to module setup.

The module is now ready to be used.

Insert the aftermarket radio in the dashboard housing and test all the functionalities.

Reassemble the dashboard carefully.

AMPLIFIER ONLY

DETERMINE IF YOU SHOULD USE RCA'S OR LEVEL MATCHING CIRCUITS

- If your vehicle is equipped with a factory amplifier you can connect the RCA wiring to the low level outputs of your aftermarket radio, or connect the level matching circuits to the speaker outputs of the aftermarket radio.
- If your aftermarket radio does not have low level outputs, has only a single RCA output, or the RCA output level is 2 volts or less then it is recommended to connect the level matching circuit to the speaker outputs. If the volume does not go loud enough using the RCA connections, the level matching circuits can be used.
- The internal amplifier in some radios is not compatible with the level matching circuit. In these cases, there will be floor noise (hissing or buzzing at low levels) when the level matching circuit is connected. Change to the RCA connections to eliminate this noise.

TROUBLESHOOTING TIPS:

- To reset the module back its factory settings, turn the key to the OFF position then disconnect all connectors from the module. Press and hold the module's programming button and connect all the connectors back to the module. Wait, the module's LED will flash RED rapidly (this may take up to 10 seconds). Release the programming button. Wait, the LED will turn solid GREEN for 2 seconds.
- For technical assistance call 1-866-427-2999 or e-mail "support@idatalink.com". Visit us at "maestro.idatalink.com/support" and "www.12voltdata.com/forum/"

WIRING DIAGRAM *with an Amplifier*



WIRING DIAGRAM *without an Amplifier*



VEHICLE WIRE REFERENCE CHART

Wire Description	Connector Name	Connector Color	Connector Type	Position	Wire Color	Polarity	Wire Location
CanH	OBDII	~	16 pin	06	Tan/Black	(Data)	OBDII connector, under driver side dash
CanL	OBDII	~	16 pin	14	Tan	(Data)	OBDII connector, under driver side dash

RADIO WIRE REFERENCE CHART

Wire Description	Polarity	Wire Color on Maestro T-Harness	Wire Color on Alpine cable	Wire Color on Kenwood cable	Wire Color on Pioneer cable
Illumination	(+)	Orange	N/A	Orange/White	Orange/White
Reverse Light	(+)	Purple/White	Orange/White	Purple/White	Purple/White
E-Brake	(-)	Lt Green	Yellow/Blue	Lt Green	Lt Green
Foot Brake	(+)	Yellow/Black	Yellow/Black	N/A	N/A
VSS (vehicle speed sensor)	(DATA)	Pink	Green/White	N/A	Pink



INSTALL GUIDE CHEVROLET TAHOE 2007-2011

RETAINS STEERING WHEEL CONTROLS, ONSTAR, BLUETOOTH, XM SATELLITE AND MORE!



PRODUCTS REQUIRED

iDatalink Maestro RR Radio Replacement Interface
iDatalink Maestro GM5+ Installation Harness

OPTIONAL ACCESSORIES

None

PROGRAMMED FIRMWARE

ADS-RR(SR)-GMS05-DS

NOTICE: Automotive Data Solutions Inc. (ADS) recommends having this installation performed by a certified technician. Logos and trademarks used here in are the properties of their respective owners.

WELCOME

Congratulations on the purchase of your iDatalink Maestro RR Radio replacement solution. You are now a few simple steps away from enjoying your new car radio with enhanced features.

Before starting your installation, please ensure that your iDatalink Maestro module is programmed with the correct firmware for your vehicle and that you carefully review the install guide.

Please note that Maestro RR will only retain functionalities that were originally available in the vehicle.

NEED HELP?

 **1 866 427-2999**

 **support@idatalink.com**

 **maestro.idatalink.com/support**
www.12voltdata.com/forum

TABLE OF CONTENTS

Before Installing	3
Installation Instructions	4
Wiring Diagram with an Amplifier	5
Wiring Diagram without an Amplifier	6
Vehicle Wire Reference Chart	7
Radio Wire Reference Chart	8

BEFORE INSTALLING

STEP 1

DETERMINE IF YOUR VEHICLE IS EQUIPPED WITH A FACTORY AMPLIFIER:

METHOD 1: Look for the following logos in the vehicle. They are usually on the speaker covers or on the radio unit. If you find any of the following logos Bose, Pioneer or Monsoon, you have a factory amplifier.



METHOD 2: Look for the following sticker in the glove box. This sticker will indicate all the Regular Production Option (RPO) codes. If you find any of the following codes UQA, UQS or UQG, you have a factory amplifier.

SERVICE PARTS IDENTIFICATION												DO NOT REMOVE	
2GCEK19N031344764						143 5 FXWH2Q			CKI5753				
AGI	AG2	AJ1	AL0	AM7	AN3	AU0	AU3	A31	B30	B4U			
B58	B81	B82	CJ3	C49	C7H	DF5	DK7	DL3	DT4	D07			
EVA	E63	FF8	FF9	GT5	G80	JC4	KC4	KNP	KUP	K34			
K47	K68	LQ9	M32	NCI	NEI	NP3	NP5	QCC	P30	QSS			
R4Y	R9U	R9Z	SAF	SLM	TRB	UC6	UK3	UQA	U2K	UFI			
UF3	UK3	VR4	VTV	VXS	V73	XSS	X88	YD6	YE9				
YSS	ZGC	ZYI	Z60	Z82	ISS	ISZ	4IU	6YT	691	692			
7YT													
BC/CC	U	8555				692							

STEP 2

IF YOUR VEHICLE IS EQUIPPED WITH A FACTORY AMPLIFIER:

Follow the installation instructions and complete the installation as shown in the wiring diagram **with an amplifier** and read the "AMPLIFIER ONLY" note to determine if you should use rca's or level matching circuits.

IF YOUR VEHICLE NOT IS EQUIPPED WITH A FACTORY AMPLIFIER:

Follow the installation instructions and complete the installation as shown in the wiring diagram **without an amplifier**.

INSTALLATION INSTRUCTIONS

STEP 1

- Unbox the aftermarket radio and locate its main harness.
- Connect the wires shown on the next page from aftermarket radio main harness to the GM5+ T-harness and match the wire functions.

STEP 2

- Connect the factory harness to the GM5+ T-harness.

STEP 3

- Access the OBDII connector located under the driver side dashboard.
- Connect the BROWN /RED wire of the GM5+ T-harness to the wire located at pin 6 of the OBDII connector. (See the vehicle wire chart reference for wire colors)
- Connect the BROWN /YELLOW wire of the GM5+ T-harness to the wire located at pin 14 of the OBDII connector. (See the vehicle wire chart reference for wire colors)

STEP 4

- Plug the aftermarket radio harnesses into the aftermarket radio.
- Plug the Data cable to the data port of the aftermarket radio.
- Insert the Audio cable into the iDataLink 3.5 mm audio jack of the aftermarket radio.

STEP 5

- Connect all the harnesses to the Maestro RR module then proceed to module setup.

The module is now ready to be used.

Insert the aftermarket radio in the dashboard housing and test all the functionalities.

Reassemble the dashboard carefully.

AMPLIFIER ONLY

DETERMINE IF YOU SHOULD USE RCA'S OR LEVEL MATCHING CIRCUITS

- If your vehicle is equipped with a factory amplifier you can connect the RCA wiring to the low level outputs of your aftermarket radio, or connect the level matching circuits to the speaker outputs of the aftermarket radio.
- If your aftermarket radio does not have low level outputs, has only a single RCA output, or the RCA output level is 2 volts or less then it is recommended to connect the level matching circuit to the speaker outputs. If the volume does not go loud enough using the RCA connections, the level matching circuits can be used.
- The internal amplifier in some radios is not compatible with the level matching circuit. In these cases, there will be floor noise (hissing or buzzing at low levels) when the level matching circuit is connected. Change to the RCA connections to eliminate this noise.

TROUBLESHOOTING TIPS:

- To reset the module back its factory settings, turn the key to the OFF position then disconnect all connectors from the module. Press and hold the module's programming button and connect all the connectors back to the module. Wait, the module's LED will flash RED rapidly (this may take up to 10 seconds). Release the programming button. Wait, the LED will turn solid GREEN for 2 seconds.
- For technical assistance call 1-866-427-2999 or e-mail "support@idatalink.com". Visit us at "maestro.idatalink.com/support" and "www.12voltdata.com/forum/"

WIRING DIAGRAM *with an Amplifier*



WIRING DIAGRAM *without an Amplifier*

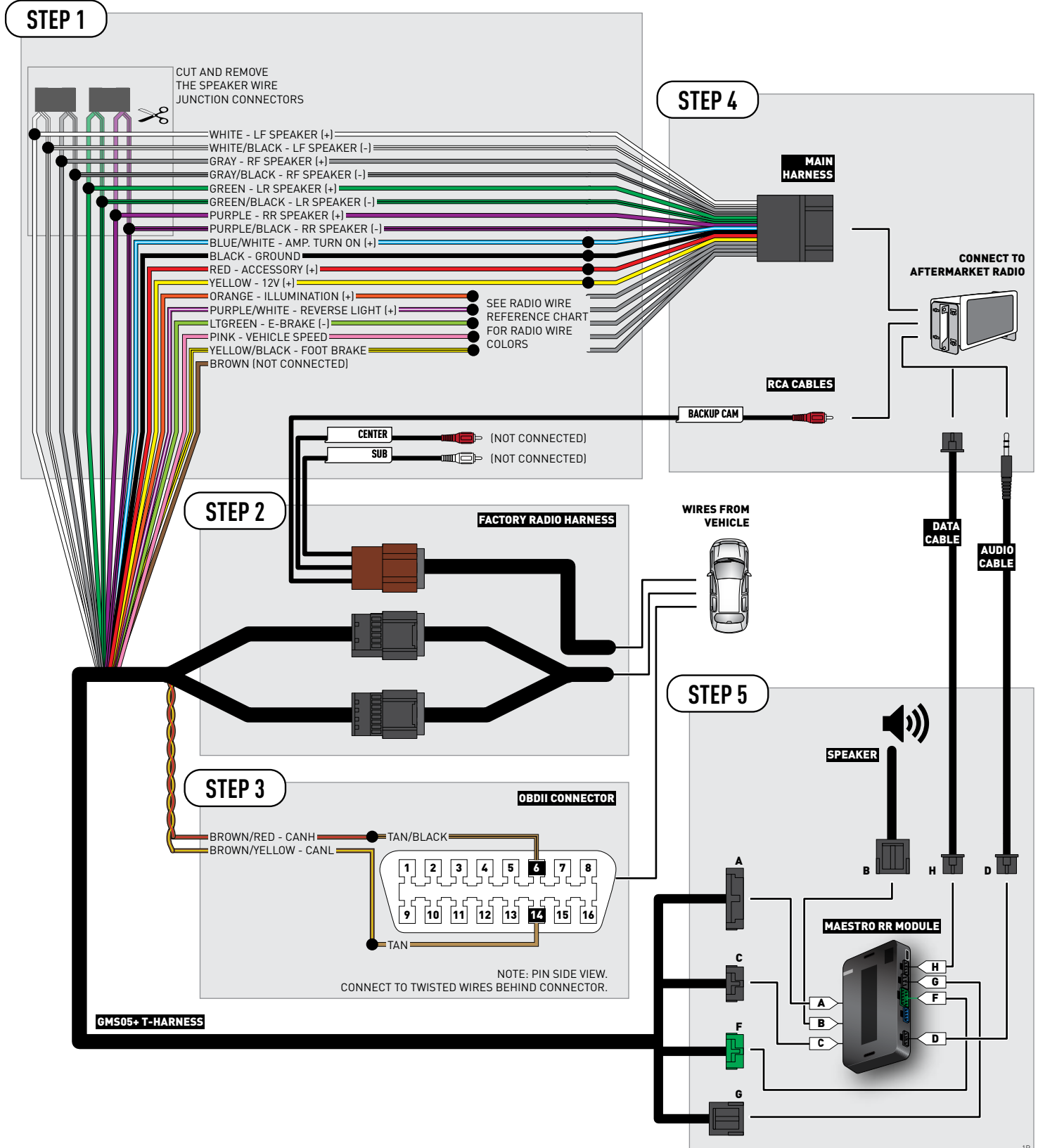

VEHICLE WIRE REFERENCE CHART

Wire Description	Connector Name	Connector Color	Connector Type	Position	Wire Color	Polarity	Wire Location
CanH	OBDII	~	16 pin	06	Tan/Black	(Data)	OBDII connector, under driver side dash
CanL	OBDII	~	16 pin	14	Tan	(Data)	OBDII connector, under driver side dash

RADIO WIRE REFERENCE CHART

Wire Description	Polarity	Wire Color on Maestro T-Harness	Wire Color on Alpine cable	Wire Color on Kenwood cable	Wire Color on Pioneer cable
Illumination	(+)	Orange	N/A	Orange/White	Orange/White
Reverse Light	(+)	Purple/White	Orange/White	Purple/White	Purple/White
E-Brake	(-)	Lt Green	Yellow/Blue	Lt Green	Lt Green
Foot Brake	(+)	Yellow/Black	Yellow/Black	N/A	N/A
VSS (vehicle speed sensor)	(DATA)	Pink	Green/White	N/A	Pink



INSTALL GUIDE CHEVROLET TAHOE WITHOUT NAV 2012-2014

RETAINS STEERING WHEEL CONTROLS, ONSTAR, BLUETOOTH, XM SATELLITE AND MORE!



PRODUCTS REQUIRED

iDatalink Maestro RR Radio Replacement Interface
iDatalink Maestro GM5+ Installation Harness

OPTIONAL ACCESSORIES

None

PROGRAMMED FIRMWARE

ADS-RR(SR)-GMS05-DS

NOTICE: Automotive Data Solutions Inc. (ADS) recommends having this installation performed by a certified technician. Logos and trademarks used here in are the properties of their respective owners.

WELCOME

Congratulations on the purchase of your iDatalink Maestro RR Radio replacement solution. You are now a few simple steps away from enjoying your new car radio with enhanced features.

Before starting your installation, please ensure that your iDatalink Maestro module is programmed with the correct firmware for your vehicle and that you carefully review the install guide.

Please note that Maestro RR will only retain functionalities that were originally available in the vehicle.

NEED HELP?

 **1 866 427-2999**

 support@idatalink.com

 maestro.idatalink.com/support
www.12voltdata.com/forum

TABLE OF CONTENTS

Before Installing	3
Installation Instructions	4
Wiring Diagram with an Amplifier	5
Wiring Diagram without an Amplifier	6
Vehicle Wire Reference Chart	7
Radio Wire Reference Chart	8

BEFORE INSTALLING

STEP 1

DETERMINE IF YOUR VEHICLE IS EQUIPPED WITH A FACTORY AMPLIFIER:

METHOD 1: Look for the following logos in the vehicle. They are usually on the speaker covers or on the radio unit. If you find any of the following logos Bose, Pioneer or Monsoon, you have a factory amplifier.



METHOD 2: Look for the following sticker in the glove box. This sticker will indicate all the Regular Production Option (RPO) codes. If you find any of the following codes UQA, UQS or UQG, you have a factory amplifier.

SERVICE PARTS IDENTIFICATION												DO NOT REMOVE	
2GCEK19N031344764						143 5 FXWH2Q			CKI5753				
AGI	AG2	AJ1	AL0	AM7	AN3	AU0	AU3	A31	B30	B4U			
B58	B81	B82	CJ3	C49	C7H	DF5	DK7	DL3	DT4	D07			
EVA	E63	FF8	FF9	GT5	G80	JC4	KC4	KNP	KUP	K34			
K47	K68	LQ9	M32	NCI	NEI	NP3	NP5	QCC	P30	QSS			
R4Y	R9U	R9Z	SAF	SLM	TRB	UC6	UK3	UQA	U2K	UFI			
UF3	UK3	VR4	VTV	VXS	V73	XSS	X88	YD6	YD6	YE9			
YSS	ZGC	ZYI	Z60	Z82	ISS	ISZ	4IU	6YT	691	692			
7YT													
BC/CC	U	8555				692							

STEP 2

IF YOUR VEHICLE IS EQUIPPED WITH A FACTORY AMPLIFIER:

Follow the installation instructions and complete the installation as shown in the wiring diagram **with an amplifier** and read the "AMPLIFIER ONLY" note to determine if you should use rca's or level matching circuits.

IF YOUR VEHICLE NOT IS EQUIPPED WITH A FACTORY AMPLIFIER:

Follow the installation instructions and complete the installation as shown in the wiring diagram **without an amplifier**.

INSTALLATION INSTRUCTIONS

STEP 1

- Unbox the aftermarket radio and locate its main harness.
- Connect the wires shown on the next page from aftermarket radio main harness to the GM5+ T-harness and match the wire functions.

STEP 2

- Connect the factory harness to the GM5+ T-harness.

STEP 3

- Access the OBDII connector located under the driver side dashboard.
- Connect the BROWN /RED wire of the GM5+ T-harness to the wire located at pin 6 of the OBDII connector. (See the vehicle wire chart reference for wire colors)
- Connect the BROWN /YELLOW wire of the GM5+ T-harness to the wire located at pin 14 of the OBDII connector. (See the vehicle wire chart reference for wire colors)

STEP 4

- Plug the aftermarket radio harnesses into the aftermarket radio.
- Plug the Data cable to the data port of the aftermarket radio.
- Insert the Audio cable into the iDataLink 3.5 mm audio jack of the aftermarket radio.

STEP 5

- Connect all the harnesses to the Maestro RR module then proceed to module setup.

The module is now ready to be used.

Insert the aftermarket radio in the dashboard housing and test all the functionalities.

Reassemble the dashboard carefully.

AMPLIFIER ONLY

DETERMINE IF YOU SHOULD USE RCA'S OR LEVEL MATCHING CIRCUITS

- If your vehicle is equipped with a factory amplifier you can connect the RCA wiring to the low level outputs of your aftermarket radio, or connect the level matching circuits to the speaker outputs of the aftermarket radio.
- If your aftermarket radio does not have low level outputs, has only a single RCA output, or the RCA output level is 2 volts or less then it is recommended to connect the level matching circuit to the speaker outputs. If the volume does not go loud enough using the RCA connections, the level matching circuits can be used.
- The internal amplifier in some radios is not compatible with the level matching circuit. In these cases, there will be floor noise (hissing or buzzing at low levels) when the level matching circuit is connected. Change to the RCA connections to eliminate this noise.

TROUBLESHOOTING TIPS:

- To reset the module back its factory settings, turn the key to the OFF position then disconnect all connectors from the module. Press and hold the module's programming button and connect all the connectors back to the module. Wait, the module's LED will flash RED rapidly (this may take up to 10 seconds). Release the programming button. Wait, the LED will turn solid GREEN for 2 seconds.
- For technical assistance call 1-866-427-2999 or e-mail "support@idatalink.com". Visit us at "maestro.idatalink.com/support" and "www.12voltdata.com/forum/"

WIRING DIAGRAM *with an Amplifier*



WIRING DIAGRAM *without an Amplifier*



VEHICLE WIRE REFERENCE CHART

Wire Description	Connector Name	Connector Color	Connector Type	Position	Wire Color	Polarity	Wire Location
CanH	OBDII	~	16 pin	06	Tan/Black	(Data)	OBDII connector, under driver side dash
CanL	OBDII	~	16 pin	14	Tan	(Data)	OBDII connector, under driver side dash

RADIO WIRE REFERENCE CHART

Wire Description	Polarity	Wire Color on Maestro T-Harness	Wire Color on Alpine cable	Wire Color on Kenwood cable	Wire Color on Pioneer cable
Illumination	(+)	Orange	N/A	Orange/White	Orange/White
Reverse Light	(+)	Purple/White	Orange/White	Purple/White	Purple/White
E-Brake	(-)	Lt Green	Yellow/Blue	Lt Green	Lt Green
Foot Brake	(+)	Yellow/Black	Yellow/Black	N/A	N/A
VSS (vehicle speed sensor)	(DATA)	Pink	Green/White	N/A	Pink



INSTALL GUIDE CHEVROLET TRAVERSE 2009-2017

RETAINS STEERING WHEEL CONTROLS, ONSTAR, BLUETOOTH, XM SATELLITE AND MORE!



PRODUCTS REQUIRED

iDatalink Maestro RR Radio Replacement Interface
iDatalink Maestro GM5+ Installation Harness

OPTIONAL ACCESSORIES

None

PROGRAMMED FIRMWARE

ADS-RR(SR)-GMS05-DS

NOTICE: Automotive Data Solutions Inc. (ADS) recommends having this installation performed by a certified technician. Logos and trademarks used here in are the properties of their respective owners.

WELCOME

Congratulations on the purchase of your iDatalink Maestro RR Radio replacement solution. You are now a few simple steps away from enjoying your new car radio with enhanced features.

Before starting your installation, please ensure that your iDatalink Maestro module is programmed with the correct firmware for your vehicle and that you carefully review the install guide.

Please note that Maestro RR will only retain functionalities that were originally available in the vehicle.

NEED HELP?

 **1 866 427-2999**

 support@idatalink.com

 maestro.idatalink.com/support
www.12voltdata.com/forum

TABLE OF CONTENTS

Before Installing	3
Installation Instructions	4
Wiring Diagram with an Amplifier	5
Wiring Diagram without an Amplifier	6
Vehicle Wire Reference Chart	7
Radio Wire Reference Chart	8

BEFORE INSTALLING

STEP 1

DETERMINE IF YOUR VEHICLE IS EQUIPPED WITH A FACTORY AMPLIFIER:

METHOD 1: Look for the following logos in the vehicle. They are usually on the speaker covers or on the radio unit. If you find any of the following logos Bose, Pioneer or Monsoon, you have a factory amplifier.



METHOD 2: Look for the following sticker in the glove box. This sticker will indicate all the Regular Production Option (RPO) codes. If you find any of the following codes UQA, UQS or UQG, you have a factory amplifier.

SERVICE PARTS IDENTIFICATION												DO NOT REMOVE	
2GCEK19N031344764						143 5 FXWH2Q			CKI5753				
AGI	AG2	AJ1	AL0	AM7	AN3	AU0	AU3	A31	B30	B4U			
B58	B81	B82	CJ3	C49	C7H	DF5	DK7	DL3	DT4	D07			
EVA	E63	FF8	FF9	GT5	G80	JC4	KC4	KNP	KUP	K34			
K47	K68	LQ9	M32	NCI	NEI	NP3	NP5	QCC	P30	QSS			
R4Y	R9U	R9Z	SAF	SLM	TRB	UC6	UK3	UQA	U2K	UFI			
UF3	UK3	VR4	VTV	VXS	V73	XSS	X88	YD6	YE9				
YSS	ZGC	ZYI	Z60	Z82	ISS	ISZ	4IU	6YT	691	692			
7YT													
BC/CC	U	8555				692							

STEP 2

IF YOUR VEHICLE IS EQUIPPED WITH A FACTORY AMPLIFIER:

Follow the installation instructions and complete the installation as shown in the wiring diagram **with an amplifier** and read the "AMPLIFIER ONLY" note to determine if you should use rca's or level matching circuits.

IF YOUR VEHICLE NOT IS EQUIPPED WITH A FACTORY AMPLIFIER:

Follow the installation instructions and complete the installation as shown in the wiring diagram **without an amplifier**.

INSTALLATION INSTRUCTIONS

STEP 1

- Unbox the aftermarket radio and locate its main harness.
- Connect the wires shown on the next page from aftermarket radio main harness to the GM5+ T-harness and match the wire functions.

STEP 2

- Connect the factory harness to the GM5+ T-harness.

STEP 3

- Access the OBDII connector located under the driver side dashboard.
- Connect the BROWN /RED wire of the GM5+ T-harness to the wire located at pin 6 of the OBDII connector. (See the vehicle wire chart reference for wire colors)
- Connect the BROWN /YELLOW wire of the GM5+ T-harness to the wire located at pin 14 of the OBDII connector. (See the vehicle wire chart reference for wire colors)

STEP 4

- Plug the aftermarket radio harnesses into the aftermarket radio.
- Plug the Data cable to the data port of the aftermarket radio.
- Insert the Audio cable into the iDataLink 3.5 mm audio jack of the aftermarket radio.

STEP 5

- Connect all the harnesses to the Maestro RR module then proceed to module setup.

The module is now ready to be used.

Insert the aftermarket radio in the dashboard housing and test all the functionalities.

Reassemble the dashboard carefully.

AMPLIFIER ONLY

DETERMINE IF YOU SHOULD USE RCA'S OR LEVEL MATCHING CIRCUITS

- If your vehicle is equipped with a factory amplifier you can connect the RCA wiring to the low level outputs of your aftermarket radio, or connect the level matching circuits to the speaker outputs of the aftermarket radio.
- If your aftermarket radio does not have low level outputs, has only a single RCA output, or the RCA output level is 2 volts or less then it is recommended to connect the level matching circuit to the speaker outputs. If the volume does not go loud enough using the RCA connections, the level matching circuits can be used.
- The internal amplifier in some radios is not compatible with the level matching circuit. In these cases, there will be floor noise (hissing or buzzing at low levels) when the level matching circuit is connected. Change to the RCA connections to eliminate this noise.

TROUBLESHOOTING TIPS:

- To reset the module back its factory settings, turn the key to the OFF position then disconnect all connectors from the module. Press and hold the module's programming button and connect all the connectors back to the module. Wait, the module's LED will flash RED rapidly (this may take up to 10 seconds). Release the programming button. Wait, the LED will turn solid GREEN for 2 seconds.
- For technical assistance call 1-866-427-2999 or e-mail "support@idatalink.com". Visit us at "maestro.idatalink.com/support" and "www.12voltdata.com/forum/"

WIRING DIAGRAM *with an Amplifier*



WIRING DIAGRAM *without an Amplifier*



VEHICLE WIRE REFERENCE CHART

Wire Description	Connector Name	Connector Color	Connector Type	Position	Wire Color	Polarity	Wire Location
CanH	OBDII	~	16 pin	06	Tan/Black	(Data)	OBDII connector, under driver side dash
CanL	OBDII	~	16 pin	14	Tan	(Data)	OBDII connector, under driver side dash

RADIO WIRE REFERENCE CHART

Wire Description	Polarity	Wire Color on Maestro T-Harness	Wire Color on Alpine cable	Wire Color on Kenwood cable	Wire Color on Pioneer cable
Illumination	(+)	Orange	N/A	Orange/White	Orange/White
Reverse Light	(+)	Purple/White	Orange/White	Purple/White	Purple/White
E-Brake	(-)	Lt Green	Yellow/Blue	Lt Green	Lt Green
Foot Brake	(+)	Yellow/Black	Yellow/Black	N/A	N/A
VSS (vehicle speed sensor)	(DATA)	Pink	Green/White	N/A	Pink



INSTALL GUIDE GMC ACADIA 2007-2014

RETAINS STEERING WHEEL CONTROLS, ONSTAR, BLUETOOTH, XM SATELLITE AND MORE!



PRODUCTS REQUIRED

iDatalink Maestro RR Radio Replacement Interface
iDatalink Maestro GM5+ Installation Harness

OPTIONAL ACCESSORIES

None

PROGRAMMED FIRMWARE

ADS-RR(SR)-GMS05-DS

NOTICE: Automotive Data Solutions Inc. (ADS) recommends having this installation performed by a certified technician. Logos and trademarks used here in are the properties of their respective owners.

WELCOME

Congratulations on the purchase of your iDatalink Maestro RR Radio replacement solution. You are now a few simple steps away from enjoying your new car radio with enhanced features.

Before starting your installation, please ensure that your iDatalink Maestro module is programmed with the correct firmware for your vehicle and that you carefully review the install guide.

Please note that Maestro RR will only retain functionalities that were originally available in the vehicle.

NEED HELP?

 **1 866 427-2999**

 support@idatalink.com

 maestro.idatalink.com/support
www.12voltdata.com/forum

TABLE OF CONTENTS

Before Installing	3
Installation Instructions	4
Wiring Diagram with an Amplifier	5
Wiring Diagram without an Amplifier	6
Vehicle Wire Reference Chart	7
Radio Wire Reference Chart	8

BEFORE INSTALLING

STEP 1

DETERMINE IF YOUR VEHICLE IS EQUIPPED WITH A FACTORY AMPLIFIER:

METHOD 1: Look for the following logos in the vehicle. They are usually on the speaker covers or on the radio unit. If you find any of the following logos Bose, Pioneer or Monsoon, you have a factory amplifier.



METHOD 2: Look for the following sticker in the glove box. This sticker will indicate all the Regular Production Option (RPO) codes. If you find any of the following codes UQA, UQS or UQG, you have a factory amplifier.

SERVICE PARTS IDENTIFICATION												DO NOT REMOVE		
2GCEK19N031344764						143 5 FXWH2Q			CKI5753					
AGI	AG2	AJ1	ALO	AM7	AN3	AU0	AU3	A31	B30	B4U				
B58	B81	B82	CJ3	C49	C7H	DF5	DK7	DL3	DT4	D07				
EVA	E63	FF8	FF9	GT5	G80	JC4	KC4	KNP	KUP	K34				
K47	K68	LQ9	M32	NCI	NEI	NP3	NP5	QCC	P30	QSS				
R4Y	R9U	R9Z	SAF	SLM	TRB	UC6	UK3	UQA	U2K	UFI				
UF3	UK3	VR4	VTV	VXS	V73	XSS	X88	YD6	YE9					
YSS	ZGC	ZYI	Z60	Z82	ISS	ISZ	4IU	6YT	691	692				
7YT														
BC/CC	U	8555				692								

STEP 2

IF YOUR VEHICLE IS EQUIPPED WITH A FACTORY AMPLIFIER:

Follow the installation instructions and complete the installation as shown in the wiring diagram **with an amplifier** and read the "AMPLIFIER ONLY" note to determine if you should use rca's or level matching circuits.

IF YOUR VEHICLE NOT IS EQUIPPED WITH A FACTORY AMPLIFIER:

Follow the installation instructions and complete the installation as shown in the wiring diagram **without an amplifier**.

INSTALLATION INSTRUCTIONS

STEP 1

- Unbox the aftermarket radio and locate its main harness.
- Connect the wires shown on the next page from aftermarket radio main harness to the GM5+ T-harness and match the wire functions.

STEP 2

- Connect the factory harness to the GM5+ T-harness.

STEP 3

- Access the OBDII connector located under the driver side dashboard.
- Connect the BROWN /RED wire of the GM5+ T-harness to the wire located at pin 6 of the OBDII connector. (See the vehicle wire chart reference for wire colors)
- Connect the BROWN /YELLOW wire of the GM5+ T-harness to the wire located at pin 14 of the OBDII connector. (See the vehicle wire chart reference for wire colors)

STEP 4

- Plug the aftermarket radio harnesses into the aftermarket radio.
- Plug the Data cable to the data port of the aftermarket radio.
- Insert the Audio cable into the iDataLink 3.5 mm audio jack of the aftermarket radio.

STEP 5

- Connect all the harnesses to the Maestro RR module then proceed to module setup.

The module is now ready to be used.

Insert the aftermarket radio in the dashboard housing and test all the functionalities.

Reassemble the dashboard carefully.

AMPLIFIER ONLY

DETERMINE IF YOU SHOULD USE RCA'S OR LEVEL MATCHING CIRCUITS

- If your vehicle is equipped with a factory amplifier you can connect the RCA wiring to the low level outputs of your aftermarket radio, or connect the level matching circuits to the speaker outputs of the aftermarket radio.
- If your aftermarket radio does not have low level outputs, has only a single RCA output, or the RCA output level is 2 volts or less then it is recommended to connect the level matching circuit to the speaker outputs. If the volume does not go loud enough using the RCA connections, the level matching circuits can be used.
- The internal amplifier in some radios is not compatible with the level matching circuit. In these cases, there will be floor noise (hissing or buzzing at low levels) when the level matching circuit is connected. Change to the RCA connections to eliminate this noise.

TROUBLESHOOTING TIPS:

- To reset the module back its factory settings, turn the key to the OFF position then disconnect all connectors from the module. Press and hold the module's programming button and connect all the connectors back to the module. Wait, the module's LED will flash RED rapidly (this may take up to 10 seconds). Release the programming button. Wait, the LED will turn solid GREEN for 2 seconds.
- For technical assistance call 1-866-427-2999 or e-mail "support@idatalink.com". Visit us at "maestro.idatalink.com/support" and "www.12voltdata.com/forum/"

WIRING DIAGRAM *with an Amplifier*



WIRING DIAGRAM *without an Amplifier*



VEHICLE WIRE REFERENCE CHART

Wire Description	Connector Name	Connector Color	Connector Type	Position	Wire Color	Polarity	Wire Location
CanH	OBDII	~	16 pin	06	Tan/Black	(Data)	OBDII connector, under driver side dash
CanL	OBDII	~	16 pin	14	Tan	(Data)	OBDII connector, under driver side dash

RADIO WIRE REFERENCE CHART

Wire Description	Polarity	Wire Color on Maestro T-Harness	Wire Color on Alpine cable	Wire Color on Kenwood cable	Wire Color on Pioneer cable
Illumination	(+)	Orange	N/A	Orange/White	Orange/White
Reverse Light	(+)	Purple/White	Orange/White	Purple/White	Purple/White
E-Brake	(-)	Lt Green	Yellow/Blue	Lt Green	Lt Green
Foot Brake	(+)	Yellow/Black	Yellow/Black	N/A	N/A
VSS (vehicle speed sensor)	(DATA)	Pink	Green/White	N/A	Pink



INSTALL GUIDE GMC SAVANA 2008-2016

RETAINS STEERING WHEEL CONTROLS, ONSTAR, BLUETOOTH, XM SATELLITE AND MORE!



PRODUCTS REQUIRED

iDatalink Maestro RR Radio Replacement Interface
iDatalink Maestro GM5+ Installation Harness

OPTIONAL ACCESSORIES

None

PROGRAMMED FIRMWARE

ADS-RR(SR)-GMS05-DS

NOTICE: Automotive Data Solutions Inc. (ADS) recommends having this installation performed by a certified technician. Logos and trademarks used here in are the properties of their respective owners.

WELCOME

Congratulations on the purchase of your iDatalink Maestro RR Radio replacement solution. You are now a few simple steps away from enjoying your new car radio with enhanced features.

Before starting your installation, please ensure that your iDatalink Maestro module is programmed with the correct firmware for your vehicle and that you carefully review the install guide.

Please note that Maestro RR will only retain functionalities that were originally available in the vehicle.

NEED HELP?

 **1 866 427-2999**

 support@idatalink.com

 maestro.idatalink.com/support
www.12voltdata.com/forum

TABLE OF CONTENTS

Before Installing	3
Installation Instructions	4
Wiring Diagram with an Amplifier	5
Wiring Diagram without an Amplifier	6
Vehicle Wire Reference Chart	7
Radio Wire Reference Chart	8

BEFORE INSTALLING

STEP 1

DETERMINE IF YOUR VEHICLE IS EQUIPPED WITH A FACTORY AMPLIFIER:

METHOD 1: Look for the following logos in the vehicle. They are usually on the speaker covers or on the radio unit. If you find any of the following logos Bose, Pioneer or Monsoon, you have a factory amplifier.



METHOD 2: Look for the following sticker in the glove box. This sticker will indicate all the Regular Production Option (RPO) codes. If you find any of the following codes UQA, UQS or UQG, you have a factory amplifier.

SERVICE PARTS IDENTIFICATION												DO NOT REMOVE	
2GCEK19N031344764						143 5 FXWH2Q			CKI5753				
AGI	AG2	AJ1	AL0	AM7	AN3	AU0	AU3	A31	B30	B4U			
B58	B81	B82	CJ3	C49	C7H	DF5	DK7	DL3	DT4	D07			
EVA	E63	FF8	FF9	GT5	G80	JC4	KC4	KNP	KUP	K34			
K47	K68	LQ9	M32	NCI	NEI	NP3	NP5	QCC	P30	QSS			
R4Y	R9U	R9Z	SAF	SLM	TRB	UC6	UK3	UQA	U2K	UFI			
UF3	UK3	VR4	VTV	VXS	V73	XSS	X88	YD6	YD6	YE9			
YSS	ZGC	ZYI	Z60	Z82	ISS	ISZ	4IU	6YT	691	692			
7YT													
BC/CC		U	8555			692							

STEP 2

IF YOUR VEHICLE IS EQUIPPED WITH A FACTORY AMPLIFIER:

Follow the installation instructions and complete the installation as shown in the wiring diagram **with an amplifier** and read the "AMPLIFIER ONLY" note to determine if you should use rca's or level matching circuits.

IF YOUR VEHICLE NOT IS EQUIPPED WITH A FACTORY AMPLIFIER:

Follow the installation instructions and complete the installation as shown in the wiring diagram **without an amplifier**.

INSTALLATION INSTRUCTIONS

STEP 1

- Unbox the aftermarket radio and locate its main harness.
- Connect the wires shown on the next page from aftermarket radio main harness to the GM5+ T-harness and match the wire functions.

STEP 2

- Connect the factory harness to the GM5+ T-harness.

STEP 3

- Access the OBDII connector located under the driver side dashboard.
- Connect the BROWN /RED wire of the GM5+ T-harness to the wire located at pin 6 of the OBDII connector. (See the vehicle wire chart reference for wire colors)
- Connect the BROWN /YELLOW wire of the GM5+ T-harness to the wire located at pin 14 of the OBDII connector. (See the vehicle wire chart reference for wire colors)

STEP 4

- Plug the aftermarket radio harnesses into the aftermarket radio.
- Plug the Data cable to the data port of the aftermarket radio.
- Insert the Audio cable into the iDataLink 3.5 mm audio jack of the aftermarket radio.

STEP 5

- Connect all the harnesses to the Maestro RR module then proceed to module setup.

The module is now ready to be used.

Insert the aftermarket radio in the dashboard housing and test all the functionalities.

Reassemble the dashboard carefully.

AMPLIFIER ONLY

DETERMINE IF YOU SHOULD USE RCA'S OR LEVEL MATCHING CIRCUITS

- If your vehicle is equipped with a factory amplifier you can connect the RCA wiring to the low level outputs of your aftermarket radio, or connect the level matching circuits to the speaker outputs of the aftermarket radio.
- If your aftermarket radio does not have low level outputs, has only a single RCA output, or the RCA output level is 2 volts or less then it is recommended to connect the level matching circuit to the speaker outputs. If the volume does not go loud enough using the RCA connections, the level matching circuits can be used.
- The internal amplifier in some radios is not compatible with the level matching circuit. In these cases, there will be floor noise (hissing or buzzing at low levels) when the level matching circuit is connected. Change to the RCA connections to eliminate this noise.

TROUBLESHOOTING TIPS:

- To reset the module back its factory settings, turn the key to the OFF position then disconnect all connectors from the module. Press and hold the module's programming button and connect all the connectors back to the module. Wait, the module's LED will flash RED rapidly (this may take up to 10 seconds). Release the programming button. Wait, the LED will turn solid GREEN for 2 seconds.
- For technical assistance call 1-866-427-2999 or e-mail "support@idatalink.com". Visit us at "maestro.idatalink.com/support" and "www.12voltdata.com/forum/"

WIRING DIAGRAM *with an Amplifier*



WIRING DIAGRAM *without an Amplifier*



VEHICLE WIRE REFERENCE CHART

Wire Description	Connector Name	Connector Color	Connector Type	Position	Wire Color	Polarity	Wire Location
CanH	OBDII	~	16 pin	06	Tan/Black	(Data)	OBDII connector, under driver side dash
CanL	OBDII	~	16 pin	14	Tan	(Data)	OBDII connector, under driver side dash

RADIO WIRE REFERENCE CHART

Wire Description	Polarity	Wire Color on Maestro T-Harness	Wire Color on Alpine cable	Wire Color on Kenwood cable	Wire Color on Pioneer cable
Illumination	(+)	Orange	N/A	Orange/White	Orange/White
Reverse Light	(+)	Purple/White	Orange/White	Purple/White	Purple/White
E-Brake	(-)	Lt Green	Yellow/Blue	Lt Green	Lt Green
Foot Brake	(+)	Yellow/Black	Yellow/Black	N/A	N/A
VSS (vehicle speed sensor)	(DATA)	Pink	Green/White	N/A	Pink



INSTALL GUIDE GMC SIERRA 1500 2007-2011

RETAINS STEERING WHEEL CONTROLS, ONSTAR, BLUETOOTH, XM SATELLITE AND MORE!



PRODUCTS REQUIRED

iDatalink Maestro RR Radio Replacement Interface
iDatalink Maestro GM5+ Installation Harness

OPTIONAL ACCESSORIES

None

PROGRAMMED FIRMWARE

ADS-RR(SR)-GMS05-DS

NOTICE: Automotive Data Solutions Inc. (ADS) recommends having this installation performed by a certified technician. Logos and trademarks used here in are the properties of their respective owners.

WELCOME

Congratulations on the purchase of your iDatalink Maestro RR Radio replacement solution. You are now a few simple steps away from enjoying your new car radio with enhanced features.

Before starting your installation, please ensure that your iDatalink Maestro module is programmed with the correct firmware for your vehicle and that you carefully review the install guide.

Please note that Maestro RR will only retain functionalities that were originally available in the vehicle.

NEED HELP?

 **1 866 427-2999**

 support@idatalink.com

 maestro.idatalink.com/support
www.12voltdata.com/forum

TABLE OF CONTENTS

Before Installing	3
Installation Instructions	4
Wiring Diagram with an Amplifier	5
Wiring Diagram without an Amplifier	6
Vehicle Wire Reference Chart	7
Radio Wire Reference Chart	8

BEFORE INSTALLING

STEP 1

DETERMINE IF YOUR VEHICLE IS EQUIPPED WITH A FACTORY AMPLIFIER:

METHOD 1: Look for the following logos in the vehicle. They are usually on the speaker covers or on the radio unit. If you find any of the following logos Bose, Pioneer or Monsoon, you have a factory amplifier.



METHOD 2: Look for the following sticker in the glove box. This sticker will indicate all the Regular Production Option (RPO) codes. If you find any of the following codes UQA, UQS or UQG, you have a factory amplifier.

SERVICE PARTS IDENTIFICATION												DO NOT REMOVE	
2GCEK19N031344764						143 5 FXWH2Q			CKI5753				
AGI	AG2	AJ1	AL0	AM7	AN3	AU0	AU3	A31	B30	B4U			
B58	B81	B82	CJ3	C49	C7H	DF5	DK7	DL3	DT4	D07			
EVA	E63	FF8	FF9	GT5	G80	JC4	KC4	KNP	KUP	K34			
K47	K68	LQ9	M32	NCI	NEI	NP3	NP5	QCC	P30	QSS			
R4Y	R9U	R9Z	SAF	SLM	TRB	UC6	UK3	UQA	U2K	UFI			
UF3	UK3	VR4	VTV	VXS	V73	XSS	X88	YD6	YD6	YE9			
YSS	ZGC	ZYI	Z60	Z82	ISS	ISZ	4IU	6YT	691	692			
7YT													
BC/CC	U	8555				692							

STEP 2

IF YOUR VEHICLE IS EQUIPPED WITH A FACTORY AMPLIFIER:

Follow the installation instructions and complete the installation as shown in the wiring diagram **with an amplifier** and read the "AMPLIFIER ONLY" note to determine if you should use rca's or level matching circuits.

IF YOUR VEHICLE NOT IS EQUIPPED WITH A FACTORY AMPLIFIER:

Follow the installation instructions and complete the installation as shown in the wiring diagram **without an amplifier**.

INSTALLATION INSTRUCTIONS

STEP 1

- Unbox the aftermarket radio and locate its main harness.
- Connect the wires shown on the next page from aftermarket radio main harness to the GM5+ T-harness and match the wire functions.

STEP 2

- Connect the factory harness to the GM5+ T-harness.

STEP 3

- Access the OBDII connector located under the driver side dashboard.
- Connect the BROWN /RED wire of the GM5+ T-harness to the wire located at pin 6 of the OBDII connector. (See the vehicle wire chart reference for wire colors)
- Connect the BROWN /YELLOW wire of the GM5+ T-harness to the wire located at pin 14 of the OBDII connector. (See the vehicle wire chart reference for wire colors)

STEP 4

- Plug the aftermarket radio harnesses into the aftermarket radio.
- Plug the Data cable to the data port of the aftermarket radio.
- Insert the Audio cable into the iDatalink 3.5 mm audio jack of the aftermarket radio.

STEP 5

- Connect all the harnesses to the Maestro RR module then proceed to module setup.

The module is now ready to be used.

Insert the aftermarket radio in the dashboard housing and test all the functionalities.

Reassemble the dashboard carefully.

AMPLIFIER ONLY

DETERMINE IF YOU SHOULD USE RCA'S OR LEVEL MATCHING CIRCUITS

- If your vehicle is equipped with a factory amplifier you can connect the RCA wiring to the low level outputs of your aftermarket radio, or connect the level matching circuits to the speaker outputs of the aftermarket radio.
- If your aftermarket radio does not have low level outputs, has only a single RCA output, or the RCA output level is 2 volts or less then it is recommended to connect the level matching circuit to the speaker outputs. If the volume does not go loud enough using the RCA connections, the level matching circuits can be used.
- The internal amplifier in some radios is not compatible with the level matching circuit. In these cases, there will be floor noise (hissing or buzzing at low levels) when the level matching circuit is connected. Change to the RCA connections to eliminate this noise.

TROUBLESHOOTING TIPS:

- To reset the module back its factory settings, turn the key to the OFF position then disconnect all connectors from the module. Press and hold the module's programming button and connect all the connectors back to the module. Wait, the module's LED will flash RED rapidly (this may take up to 10 seconds). Release the programming button. Wait, the LED will turn solid GREEN for 2 seconds.
- For technical assistance call 1-866-427-2999 or e-mail "support@idatalink.com". Visit us at "maestro.idatalink.com/support" and "www.12voltdata.com/forum/"

WIRING DIAGRAM *with an Amplifier*



WIRING DIAGRAM *without an Amplifier*



VEHICLE WIRE REFERENCE CHART

Wire Description	Connector Name	Connector Color	Connector Type	Position	Wire Color	Polarity	Wire Location
CanH	OBDII	~	16 pin	06	Tan/Black	(Data)	OBDII connector, under driver side dash
CanL	OBDII	~	16 pin	14	Tan	(Data)	OBDII connector, under driver side dash

RADIO WIRE REFERENCE CHART

Wire Description	Polarity	Wire Color on Maestro T-Harness	Wire Color on Alpine cable	Wire Color on Kenwood cable	Wire Color on Pioneer cable
Illumination	(+)	Orange	N/A	Orange/White	Orange/White
Reverse Light	(+)	Purple/White	Orange/White	Purple/White	Purple/White
E-Brake	(-)	Lt Green	Yellow/Blue	Lt Green	Lt Green
Foot Brake	(+)	Yellow/Black	Yellow/Black	N/A	N/A
VSS (vehicle speed sensor)	(DATA)	Pink	Green/White	N/A	Pink



INSTALL GUIDE GMC SIERRA 1500 WITHOUT NAV 2012-2014

RETAINS STEERING WHEEL CONTROLS, ONSTAR, BLUETOOTH, XM SATELLITE AND MORE!



PRODUCTS REQUIRED

iDatalink Maestro RR Radio Replacement Interface
iDatalink Maestro GM5+ Installation Harness

OPTIONAL ACCESSORIES

None

PROGRAMMED FIRMWARE

ADS-RR(SR)-GMS05-DS

NOTICE: Automotive Data Solutions Inc. (ADS) recommends having this installation performed by a certified technician. Logos and trademarks used here in are the properties of their respective owners.

WELCOME

Congratulations on the purchase of your iDatalink Maestro RR Radio replacement solution. You are now a few simple steps away from enjoying your new car radio with enhanced features.

Before starting your installation, please ensure that your iDatalink Maestro module is programmed with the correct firmware for your vehicle and that you carefully review the install guide.

Please note that Maestro RR will only retain functionalities that were originally available in the vehicle.

NEED HELP?

 **1 866 427-2999**

 support@idatalink.com

 maestro.idatalink.com/support
www.12voltdata.com/forum

TABLE OF CONTENTS

Before Installing	3
Installation Instructions	4
Wiring Diagram with an Amplifier	5
Wiring Diagram without an Amplifier	6
Vehicle Wire Reference Chart	7
Radio Wire Reference Chart	8

BEFORE INSTALLING

STEP 1

DETERMINE IF YOUR VEHICLE IS EQUIPPED WITH A FACTORY AMPLIFIER:

METHOD 1: Look for the following logos in the vehicle. They are usually on the speaker covers or on the radio unit. If you find any of the following logos Bose, Pioneer or Monsoon, you have a factory amplifier.



METHOD 2: Look for the following sticker in the glove box. This sticker will indicate all the Regular Production Option (RPO) codes. If you find any of the following codes UQA, UQS or UQG, you have a factory amplifier.

SERVICE PARTS IDENTIFICATION										DO NOT REMOVE		
2GCEK19N031344764				143 5 FXWH2Q				CKI5753				
AGI	AG2	AJ1	AL0	AM7	AN3	AU0	AU3	A31	B30	B4U		
B58	B81	B82	CJ3	C49	C7H	DF5	DK7	DL3	DT4	D07		
EVA	E63	FF8	FF9	GT5	G80	JC4	KC4	KNP	KUP	K34		
K47	K68	LQ9	M32	NCI	NEI	NP3	NP5	QCC	P30	QSS		
R4Y	R9U	R9Z	SAF	SLM	TRB	UC6	UK3	UQA	U2K	UFI		
UF3	UK3	VR4	VTV	VXS	V73	XSS	X88	YD6	YE9	YE9		
YSS	ZGC	ZYI	Z60	Z82	ISS	ISZ	4IU	6YT	691	692		
7YT												
BC/CC	U	8555				692						

STEP 2

IF YOUR VEHICLE IS EQUIPPED WITH A FACTORY AMPLIFIER:

Follow the installation instructions and complete the installation as shown in the wiring diagram **with an amplifier** and read the "AMPLIFIER ONLY" note to determine if you should use rca's or level matching circuits.

IF YOUR VEHICLE NOT IS EQUIPPED WITH A FACTORY AMPLIFIER:

Follow the installation instructions and complete the installation as shown in the wiring diagram **without an amplifier**.

INSTALLATION INSTRUCTIONS

STEP 1

- Unbox the aftermarket radio and locate its main harness.
- Connect the wires shown on the next page from aftermarket radio main harness to the GM5+ T-harness and match the wire functions.

STEP 2

- Connect the factory harness to the GM5+ T-harness.

STEP 3

- Access the OBDII connector located under the driver side dashboard.
- Connect the BROWN /RED wire of the GM5+ T-harness to the wire located at pin 6 of the OBDII connector. (See the vehicle wire chart reference for wire colors)
- Connect the BROWN /YELLOW wire of the GM5+ T-harness to the wire located at pin 14 of the OBDII connector. (See the vehicle wire chart reference for wire colors)

STEP 4

- Plug the aftermarket radio harnesses into the aftermarket radio.
- Plug the Data cable to the data port of the aftermarket radio.
- Insert the Audio cable into the iDatalink 3.5 mm audio jack of the aftermarket radio.

STEP 5

- Connect all the harnesses to the Maestro RR module then proceed to module setup.

The module is now ready to be used.

Insert the aftermarket radio in the dashboard housing and test all the functionalities.

Reassemble the dashboard carefully.

AMPLIFIER ONLY

DETERMINE IF YOU SHOULD USE RCA'S OR LEVEL MATCHING CIRCUITS

- If your vehicle is equipped with a factory amplifier you can connect the RCA wiring to the low level outputs of your aftermarket radio, or connect the level matching circuits to the speaker outputs of the aftermarket radio.
- If your aftermarket radio does not have low level outputs, has only a single RCA output, or the RCA output level is 2 volts or less then it is recommended to connect the level matching circuit to the speaker outputs. If the volume does not go loud enough using the RCA connections, the level matching circuits can be used.
- The internal amplifier in some radios is not compatible with the level matching circuit. In these cases, there will be floor noise (hissing or buzzing at low levels) when the level matching circuit is connected. Change to the RCA connections to eliminate this noise.

TROUBLESHOOTING TIPS:

- To reset the module back its factory settings, turn the key to the OFF position then disconnect all connectors from the module. Press and hold the module's programming button and connect all the connectors back to the module. Wait, the module's LED will flash RED rapidly (this may take up to 10 seconds). Release the programming button. Wait, the LED will turn solid GREEN for 2 seconds.
- For technical assistance call 1-866-427-2999 or e-mail "support@idatalink.com". Visit us at "maestro.idatalink.com/support" and "www.12voltdata.com/forum/"

WIRING DIAGRAM *with an Amplifier*



WIRING DIAGRAM *without an Amplifier*



VEHICLE WIRE REFERENCE CHART

Wire Description	Connector Name	Connector Color	Connector Type	Position	Wire Color	Polarity	Wire Location
CanH	OBDII	~	16 pin	06	Tan/Black	(Data)	OBDII connector, under driver side dash
CanL	OBDII	~	16 pin	14	Tan	(Data)	OBDII connector, under driver side dash

RADIO WIRE REFERENCE CHART

Wire Description	Polarity	Wire Color on Maestro T-Harness	Wire Color on Alpine cable	Wire Color on Kenwood cable	Wire Color on Pioneer cable
Illumination	(+)	Orange	N/A	Orange/White	Orange/White
Reverse Light	(+)	Purple/White	Orange/White	Purple/White	Purple/White
E-Brake	(-)	Lt Green	Yellow/Blue	Lt Green	Lt Green
Foot Brake	(+)	Yellow/Black	Yellow/Black	N/A	N/A
VSS (vehicle speed sensor)	(DATA)	Pink	Green/White	N/A	Pink



INSTALL GUIDE GMC SIERRA 2500 & 3500 2007-2011

RETAINS STEERING WHEEL CONTROLS, ONSTAR, BLUETOOTH, XM SATELLITE AND MORE!



PRODUCTS REQUIRED

iDatalink Maestro RR Radio Replacement Interface
iDatalink Maestro GM5+ Installation Harness

OPTIONAL ACCESSORIES

None

PROGRAMMED FIRMWARE

ADS-RR(SR)-GMS05-DS

NOTICE: Automotive Data Solutions Inc. (ADS) recommends having this installation performed by a certified technician. Logos and trademarks used here in are the properties of their respective owners.

WELCOME

Congratulations on the purchase of your iDatalink Maestro RR Radio replacement solution. You are now a few simple steps away from enjoying your new car radio with enhanced features.

Before starting your installation, please ensure that your iDatalink Maestro module is programmed with the correct firmware for your vehicle and that you carefully review the install guide.

Please note that Maestro RR will only retain functionalities that were originally available in the vehicle.

NEED HELP?

 **1 866 427-2999**

 support@idatalink.com

 maestro.idatalink.com/support
www.12voltdata.com/forum

TABLE OF CONTENTS

Before Installing	3
Installation Instructions	4
Wiring Diagram with an Amplifier	5
Wiring Diagram without an Amplifier	6
Vehicle Wire Reference Chart	7
Radio Wire Reference Chart	8

BEFORE INSTALLING

STEP 1

DETERMINE IF YOUR VEHICLE IS EQUIPPED WITH A FACTORY AMPLIFIER:

METHOD 1: Look for the following logos in the vehicle. They are usually on the speaker covers or on the radio unit. If you find any of the following logos Bose, Pioneer or Monsoon, you have a factory amplifier.



METHOD 2: Look for the following sticker in the glove box. This sticker will indicate all the Regular Production Option (RPO) codes. If you find any of the following codes UQA, UQS or UQG, you have a factory amplifier.

SERVICE PARTS IDENTIFICATION												DO NOT REMOVE	
2GCEK19N031344764						143 5 FXWH2Q			CKI5753				
AGI	AG2	AJ1	AL0	AM7	AN3	AU0	AU3	A31	B30	B4U			
B58	B81	B82	CJ3	C49	C7H	DF5	DK7	DL3	DT4	D07			
EVA	E63	FF8	FF9	GT5	G80	JC4	KC4	KNP	KUP	K34			
K47	K68	LQ9	M32	NCI	NEI	NP3	NP5	QCC	P30	QSS			
R4Y	R9U	R9Z	SAF	SLM	TRB	UC6	UK3	UQA	U2K	UFI			
UF3	UK3	VR4	VTV	VXS	V73	XSS	X88	YD6	YD6	YE9			
YSS	ZGC	ZYI	Z60	Z82	ISS	ISZ	4IU	6YT	691	692			
7YT													
BC/CC	U	8555				692							

STEP 2

IF YOUR VEHICLE IS EQUIPPED WITH A FACTORY AMPLIFIER:

Follow the installation instructions and complete the installation as shown in the wiring diagram **with an amplifier** and read the "AMPLIFIER ONLY" note to determine if you should use rca's or level matching circuits.

IF YOUR VEHICLE NOT IS EQUIPPED WITH A FACTORY AMPLIFIER:

Follow the installation instructions and complete the installation as shown in the wiring diagram **without an amplifier**.

INSTALLATION INSTRUCTIONS

STEP 1

- Unbox the aftermarket radio and locate its main harness.
- Connect the wires shown on the next page from aftermarket radio main harness to the GM5+ T-harness and match the wire functions.

STEP 2

- Connect the factory harness to the GM5+ T-harness.

STEP 3

- Access the OBDII connector located under the driver side dashboard.
- Connect the BROWN /RED wire of the GM5+ T-harness to the wire located at pin 6 of the OBDII connector. (See the vehicle wire chart reference for wire colors)
- Connect the BROWN /YELLOW wire of the GM5+ T-harness to the wire located at pin 14 of the OBDII connector. (See the vehicle wire chart reference for wire colors)

STEP 4

- Plug the aftermarket radio harnesses into the aftermarket radio.
- Plug the Data cable to the data port of the aftermarket radio.
- Insert the Audio cable into the iDatalink 3.5 mm audio jack of the aftermarket radio.

STEP 5

- Connect all the harnesses to the Maestro RR module then proceed to module setup.

The module is now ready to be used.

Insert the aftermarket radio in the dashboard housing and test all the functionalities.

Reassemble the dashboard carefully.

AMPLIFIER ONLY

DETERMINE IF YOU SHOULD USE RCA'S OR LEVEL MATCHING CIRCUITS

- If your vehicle is equipped with a factory amplifier you can connect the RCA wiring to the low level outputs of your aftermarket radio, or connect the level matching circuits to the speaker outputs of the aftermarket radio.
- If your aftermarket radio does not have low level outputs, has only a single RCA output, or the RCA output level is 2 volts or less then it is recommended to connect the level matching circuit to the speaker outputs. If the volume does not go loud enough using the RCA connections, the level matching circuits can be used.
- The internal amplifier in some radios is not compatible with the level matching circuit. In these cases, there will be floor noise (hissing or buzzing at low levels) when the level matching circuit is connected. Change to the RCA connections to eliminate this noise.

TROUBLESHOOTING TIPS:

- To reset the module back its factory settings, turn the key to the OFF position then disconnect all connectors from the module. Press and hold the module's programming button and connect all the connectors back to the module. Wait, the module's LED will flash RED rapidly (this may take up to 10 seconds). Release the programming button. Wait, the LED will turn solid GREEN for 2 seconds.
- For technical assistance call 1-866-427-2999 or e-mail "support@idatalink.com". Visit us at "maestro.idatalink.com/support" and "www.12voltdata.com/forum/"

WIRING DIAGRAM *with an Amplifier*



WIRING DIAGRAM *without an Amplifier*



VEHICLE WIRE REFERENCE CHART

Wire Description	Connector Name	Connector Color	Connector Type	Position	Wire Color	Polarity	Wire Location
CanH	OBDII	~	16 pin	06	Tan/Black	(Data)	OBDII connector, under driver side dash
CanL	OBDII	~	16 pin	14	Tan	(Data)	OBDII connector, under driver side dash

RADIO WIRE REFERENCE CHART

Wire Description	Polarity	Wire Color on Maestro T-Harness	Wire Color on Alpine cable	Wire Color on Kenwood cable	Wire Color on Pioneer cable
Illumination	(+)	Orange	N/A	Orange/White	Orange/White
Reverse Light	(+)	Purple/White	Orange/White	Purple/White	Purple/White
E-Brake	(-)	Lt Green	Yellow/Blue	Lt Green	Lt Green
Foot Brake	(+)	Yellow/Black	Yellow/Black	N/A	N/A
VSS (vehicle speed sensor)	(DATA)	Pink	Green/White	N/A	Pink



INSTALL GUIDE GMC SIERRA 2500 & 3500 WITHOUT NAV 2012-2014

RETAINS STEERING WHEEL CONTROLS, ONSTAR, BLUETOOTH, XM SATELLITE AND MORE!



PRODUCTS REQUIRED

iDatalink Maestro RR Radio Replacement Interface
iDatalink Maestro GM5+ Installation Harness

OPTIONAL ACCESSORIES

None

PROGRAMMED FIRMWARE

ADS-RR(SR)-GMS05-DS

NOTICE: Automotive Data Solutions Inc. (ADS) recommends having this installation performed by a certified technician. Logos and trademarks used here in are the properties of their respective owners.

WELCOME

Congratulations on the purchase of your iDatalink Maestro RR Radio replacement solution. You are now a few simple steps away from enjoying your new car radio with enhanced features.

Before starting your installation, please ensure that your iDatalink Maestro module is programmed with the correct firmware for your vehicle and that you carefully review the install guide.

Please note that Maestro RR will only retain functionalities that were originally available in the vehicle.

NEED HELP?

 **1 866 427-2999**

 support@idatalink.com

 maestro.idatalink.com/support
www.12voltdata.com/forum

TABLE OF CONTENTS

Before Installing	3
Installation Instructions	4
Wiring Diagram with an Amplifier	5
Wiring Diagram without an Amplifier	6
Vehicle Wire Reference Chart	7
Radio Wire Reference Chart	8

BEFORE INSTALLING

STEP 1

DETERMINE IF YOUR VEHICLE IS EQUIPPED WITH A FACTORY AMPLIFIER:

METHOD 1: Look for the following logos in the vehicle. They are usually on the speaker covers or on the radio unit. If you find any of the following logos Bose, Pioneer or Monsoon, you have a factory amplifier.



METHOD 2: Look for the following sticker in the glove box. This sticker will indicate all the Regular Production Option (RPO) codes. If you find any of the following codes UQA, UQS or UQG, you have a factory amplifier.

SERVICE PARTS IDENTIFICATION												DO NOT REMOVE	
2GCEK19N031344764						143 5 FXWH2Q			CKI5753				
AGI	AG2	AJ1	ALO	AM7	AN3	AU0	AU3	A31	B30	B4U			
B58	B81	B82	CJ3	C49	C7H	DF5	DK7	DL3	DT4	D07			
EVA	E63	FF8	FF9	GT5	G80	JC4	KC4	KNP	KUP	K34			
K47	K68	LQ9	M32	NCI	NEI	NP3	NP5	QCC	P30	QSS			
R4Y	R9U	R9Z	SAF	SLM	TRB	UC6	UK3	UQA	U2K	UFI			
UF3	UK3	VR4	VTV	VXS	V73	XSS	X88	YD6	YE9				
YSS	ZGC	ZYI	Z60	Z82	ISS	ISZ	4IU	6YT	691	692			
7YT													
BC/CC	U	8555				692							

STEP 2

IF YOUR VEHICLE IS EQUIPPED WITH A FACTORY AMPLIFIER:

Follow the installation instructions and complete the installation as shown in the wiring diagram **with an amplifier** and read the "AMPLIFIER ONLY" note to determine if you should use rca's or level matching circuits.

IF YOUR VEHICLE NOT IS EQUIPPED WITH A FACTORY AMPLIFIER:

Follow the installation instructions and complete the installation as shown in the wiring diagram **without an amplifier**.

INSTALLATION INSTRUCTIONS

STEP 1

- Unbox the aftermarket radio and locate its main harness.
- Connect the wires shown on the next page from aftermarket radio main harness to the GM5+ T-harness and match the wire functions.

STEP 2

- Connect the factory harness to the GM5+ T-harness.

STEP 3

- Access the OBDII connector located under the driver side dashboard.
- Connect the BROWN /RED wire of the GM5+ T-harness to the wire located at pin 6 of the OBDII connector. (See the vehicle wire chart reference for wire colors)
- Connect the BROWN /YELLOW wire of the GM5+ T-harness to the wire located at pin 14 of the OBDII connector. (See the vehicle wire chart reference for wire colors)

STEP 4

- Plug the aftermarket radio harnesses into the aftermarket radio.
- Plug the Data cable to the data port of the aftermarket radio.
- Insert the Audio cable into the iDataLink 3.5 mm audio jack of the aftermarket radio.

STEP 5

- Connect all the harnesses to the Maestro RR module then proceed to module setup.

The module is now ready to be used.

Insert the aftermarket radio in the dashboard housing and test all the functionalities.

Reassemble the dashboard carefully.

AMPLIFIER ONLY

DETERMINE IF YOU SHOULD USE RCA'S OR LEVEL MATCHING CIRCUITS

- If your vehicle is equipped with a factory amplifier you can connect the RCA wiring to the low level outputs of your aftermarket radio, or connect the level matching circuits to the speaker outputs of the aftermarket radio.
- If your aftermarket radio does not have low level outputs, has only a single RCA output, or the RCA output level is 2 volts or less then it is recommended to connect the level matching circuit to the speaker outputs. If the volume does not go loud enough using the RCA connections, the level matching circuits can be used.
- The internal amplifier in some radios is not compatible with the level matching circuit. In these cases, there will be floor noise (hissing or buzzing at low levels) when the level matching circuit is connected. Change to the RCA connections to eliminate this noise.

TROUBLESHOOTING TIPS:

- To reset the module back its factory settings, turn the key to the OFF position then disconnect all connectors from the module. Press and hold the module's programming button and connect all the connectors back to the module. Wait, the module's LED will flash RED rapidly (this may take up to 10 seconds). Release the programming button. Wait, the LED will turn solid GREEN for 2 seconds.
- For technical assistance call 1-866-427-2999 or e-mail "support@idatalink.com". Visit us at "maestro.idatalink.com/support" and "www.12voltdata.com/forum/"

WIRING DIAGRAM *with an Amplifier*



WIRING DIAGRAM *without an Amplifier*



VEHICLE WIRE REFERENCE CHART

Wire Description	Connector Name	Connector Color	Connector Type	Position	Wire Color	Polarity	Wire Location
CanH	OBDII	~	16 pin	06	Tan/Black	(Data)	OBDII connector, under driver side dash
CanL	OBDII	~	16 pin	14	Tan	(Data)	OBDII connector, under driver side dash

RADIO WIRE REFERENCE CHART

Wire Description	Polarity	Wire Color on Maestro T-Harness	Wire Color on Alpine cable	Wire Color on Kenwood cable	Wire Color on Pioneer cable
Illumination	(+)	Orange	N/A	Orange/White	Orange/White
Reverse Light	(+)	Purple/White	Orange/White	Purple/White	Purple/White
E-Brake	(-)	Lt Green	Yellow/Blue	Lt Green	Lt Green
Foot Brake	(+)	Yellow/Black	Yellow/Black	N/A	N/A
VSS (vehicle speed sensor)	(DATA)	Pink	Green/White	N/A	Pink



INSTALL GUIDE GMC YUKON 2007-2011

RETAINS STEERING WHEEL CONTROLS, ONSTAR, BLUETOOTH, XM SATELLITE AND MORE!



PRODUCTS REQUIRED

iDatalink Maestro RR Radio Replacement Interface
iDatalink Maestro GM5+ Installation Harness

OPTIONAL ACCESSORIES

None

PROGRAMMED FIRMWARE

ADS-RR(SR)-GMS05-DS

NOTICE: Automotive Data Solutions Inc. (ADS) recommends having this installation performed by a certified technician. Logos and trademarks used here in are the properties of their respective owners.

WELCOME

Congratulations on the purchase of your iDatalink Maestro RR Radio replacement solution. You are now a few simple steps away from enjoying your new car radio with enhanced features.

Before starting your installation, please ensure that your iDatalink Maestro module is programmed with the correct firmware for your vehicle and that you carefully review the install guide.

Please note that Maestro RR will only retain functionalities that were originally available in the vehicle.

NEED HELP?

 **1 866 427-2999**

 support@idatalink.com

 maestro.idatalink.com/support
www.12voltdata.com/forum

TABLE OF CONTENTS

Before Installing	3
Installation Instructions	4
Wiring Diagram with an Amplifier	5
Wiring Diagram without an Amplifier	6
Vehicle Wire Reference Chart	7
Radio Wire Reference Chart	8

BEFORE INSTALLING

STEP 1

DETERMINE IF YOUR VEHICLE IS EQUIPPED WITH A FACTORY AMPLIFIER:

METHOD 1: Look for the following logos in the vehicle. They are usually on the speaker covers or on the radio unit. If you find any of the following logos Bose, Pioneer or Monsoon, you have a factory amplifier.



METHOD 2: Look for the following sticker in the glove box. This sticker will indicate all the Regular Production Option (RPO) codes. If you find any of the following codes UQA, UQS or UQG, you have a factory amplifier.

SERVICE PARTS IDENTIFICATION												DO NOT REMOVE	
2GCEK19N031344764						143 5 FXWH2Q			CKI5753				
AGI	AG2	AJ1	AL0	AM7	AN3	AU0	AU3	A31	B30	B4U			
B58	B81	B82	CJ3	C49	C7H	DF5	DK7	DL3	DT4	D07			
EVA	E63	FF8	FF9	GT5	G80	JC4	KC4	KNP	KUP	K34			
K47	K68	LQ9	M32	NCI	NEI	NP3	NP5	QCC	P30	QSS			
R4Y	R9U	R9Z	SAF	SLM	TRB	UC6	UK3	UQA	U2K	UFI			
UF3	UK3	VR4	VTV	VXS	V73	XSS	X88	YD6	YE9				
YSS	ZGC	ZYI	Z60	Z82	ISS	ISZ	4IU	6YT	691	692			
7YT													
BC/CC	U	8555				692							

STEP 2

IF YOUR VEHICLE IS EQUIPPED WITH A FACTORY AMPLIFIER:

Follow the installation instructions and complete the installation as shown in the wiring diagram **with an amplifier** and read the "AMPLIFIER ONLY" note to determine if you should use rca's or level matching circuits.

IF YOUR VEHICLE NOT IS EQUIPPED WITH A FACTORY AMPLIFIER:

Follow the installation instructions and complete the installation as shown in the wiring diagram **without an amplifier**.

INSTALLATION INSTRUCTIONS

STEP 1

- Unbox the aftermarket radio and locate its main harness.
- Connect the wires shown on the next page from aftermarket radio main harness to the GM5+ T-harness and match the wire functions.

STEP 2

- Connect the factory harness to the GM5+ T-harness.

STEP 3

- Access the OBDII connector located under the driver side dashboard.
- Connect the BROWN /RED wire of the GM5+ T-harness to the wire located at pin 6 of the OBDII connector. (See the vehicle wire chart reference for wire colors)
- Connect the BROWN /YELLOW wire of the GM5+ T-harness to the wire located at pin 14 of the OBDII connector. (See the vehicle wire chart reference for wire colors)

STEP 4

- Plug the aftermarket radio harnesses into the aftermarket radio.
- Plug the Data cable to the data port of the aftermarket radio.
- Insert the Audio cable into the iDatalink 3.5 mm audio jack of the aftermarket radio.

STEP 5

- Connect all the harnesses to the Maestro RR module then proceed to module setup.

The module is now ready to be used.

Insert the aftermarket radio in the dashboard housing and test all the functionalities.

Reassemble the dashboard carefully.

AMPLIFIER ONLY

DETERMINE IF YOU SHOULD USE RCA'S OR LEVEL MATCHING CIRCUITS

- If your vehicle is equipped with a factory amplifier you can connect the RCA wiring to the low level outputs of your aftermarket radio, or connect the level matching circuits to the speaker outputs of the aftermarket radio.
- If your aftermarket radio does not have low level outputs, has only a single RCA output, or the RCA output level is 2 volts or less then it is recommended to connect the level matching circuit to the speaker outputs. If the volume does not go loud enough using the RCA connections, the level matching circuits can be used.
- The internal amplifier in some radios is not compatible with the level matching circuit. In these cases, there will be floor noise (hissing or buzzing at low levels) when the level matching circuit is connected. Change to the RCA connections to eliminate this noise.

TROUBLESHOOTING TIPS:

- To reset the module back its factory settings, turn the key to the OFF position then disconnect all connectors from the module. Press and hold the module's programming button and connect all the connectors back to the module. Wait, the module's LED will flash RED rapidly (this may take up to 10 seconds). Release the programming button. Wait, the LED will turn solid GREEN for 2 seconds.
- For technical assistance call 1-866-427-2999 or e-mail "support@idatalink.com". Visit us at "maestro.idatalink.com/support" and "www.12voltdata.com/forum/"

WIRING DIAGRAM *with an Amplifier*



WIRING DIAGRAM *without an Amplifier*



VEHICLE WIRE REFERENCE CHART

Wire Description	Connector Name	Connector Color	Connector Type	Position	Wire Color	Polarity	Wire Location
CanH	OBDII	~	16 pin	06	Tan/Black	(Data)	OBDII connector, under driver side dash
CanL	OBDII	~	16 pin	14	Tan	(Data)	OBDII connector, under driver side dash

RADIO WIRE REFERENCE CHART

Wire Description	Polarity	Wire Color on Maestro T-Harness	Wire Color on Alpine cable	Wire Color on Kenwood cable	Wire Color on Pioneer cable
Illumination	(+)	Orange	N/A	Orange/White	Orange/White
Reverse Light	(+)	Purple/White	Orange/White	Purple/White	Purple/White
E-Brake	(-)	Lt Green	Yellow/Blue	Lt Green	Lt Green
Foot Brake	(+)	Yellow/Black	Yellow/Black	N/A	N/A
VSS (vehicle speed sensor)	(DATA)	Pink	Green/White	N/A	Pink



INSTALL GUIDE GMC YUKON WITHOUT NAV 2012-2014

RETAINS STEERING WHEEL CONTROLS, ONSTAR, BLUETOOTH, XM SATELLITE AND MORE!



PRODUCTS REQUIRED

iDatalink Maestro RR Radio Replacement Interface
iDatalink Maestro GM5+ Installation Harness

OPTIONAL ACCESSORIES

None

PROGRAMMED FIRMWARE

ADS-RR(SR)-GMS05-DS

NOTICE: Automotive Data Solutions Inc. (ADS) recommends having this installation performed by a certified technician. Logos and trademarks used here in are the properties of their respective owners.

WELCOME

Congratulations on the purchase of your iDatalink Maestro RR Radio replacement solution. You are now a few simple steps away from enjoying your new car radio with enhanced features.

Before starting your installation, please ensure that your iDatalink Maestro module is programmed with the correct firmware for your vehicle and that you carefully review the install guide.

Please note that Maestro RR will only retain functionalities that were originally available in the vehicle.

NEED HELP?

 **1 866 427-2999**

 support@idatalink.com

 maestro.idatalink.com/support
www.12voltdata.com/forum

TABLE OF CONTENTS

Before Installing	3
Installation Instructions	4
Wiring Diagram with an Amplifier	5
Wiring Diagram without an Amplifier	6
Vehicle Wire Reference Chart	7
Radio Wire Reference Chart	8

BEFORE INSTALLING

STEP 1

DETERMINE IF YOUR VEHICLE IS EQUIPPED WITH A FACTORY AMPLIFIER:

METHOD 1: Look for the following logos in the vehicle. They are usually on the speaker covers or on the radio unit. If you find any of the following logos Bose, Pioneer or Monsoon, you have a factory amplifier.



METHOD 2: Look for the following sticker in the glove box. This sticker will indicate all the Regular Production Option (RPO) codes. If you find any of the following codes UQA, UQS or UQG, you have a factory amplifier.

SERVICE PARTS IDENTIFICATION												DO NOT REMOVE	
2GCEK19N031344764						143 5 FXWH2Q			CKI5753				
AG1	AG2	AJ1	AL0	AM7	AN3	AU0	AU3	A31	B30	B4U			
B58	B81	B82	CJ3	C49	C7H	DF5	DK7	DL3	DT4	D07			
EVA	E63	FF8	FF9	GT5	G80	JC4	KC4	KNP	KUP	K34			
K47	K68	LQ9	M32	NCI	NEI	NP3	NP5	QCC	P30	QSS			
R4Y	R9U	R9Z	SAF	SLM	TRB	UC6	UK3	UQA	U2K	UFI			
UF3	UK3	VR4	VTV	VXS	V73	XSS	X88	YD6	YE9				
YSS	ZGC	ZYI	Z60	Z82	ISS	ISZ	4IU	6YT	691	692			
7YT													
BC/CC	U	8555				692							

STEP 2

IF YOUR VEHICLE IS EQUIPPED WITH A FACTORY AMPLIFIER:

Follow the installation instructions and complete the installation as shown in the wiring diagram **with an amplifier** and read the "AMPLIFIER ONLY" note to determine if you should use rca's or level matching circuits.

IF YOUR VEHICLE NOT IS EQUIPPED WITH A FACTORY AMPLIFIER:

Follow the installation instructions and complete the installation as shown in the wiring diagram **without an amplifier**.

INSTALLATION INSTRUCTIONS

STEP 1

- Unbox the aftermarket radio and locate its main harness.
- Connect the wires shown on the next page from aftermarket radio main harness to the GM5+ T-harness and match the wire functions.

STEP 2

- Connect the factory harness to the GM5+ T-harness.

STEP 3

- Access the OBDII connector located under the driver side dashboard.
- Connect the BROWN /RED wire of the GM5+ T-harness to the wire located at pin 6 of the OBDII connector. (See the vehicle wire chart reference for wire colors)
- Connect the BROWN /YELLOW wire of the GM5+ T-harness to the wire located at pin 14 of the OBDII connector. (See the vehicle wire chart reference for wire colors)

STEP 4

- Plug the aftermarket radio harnesses into the aftermarket radio.
- Plug the Data cable to the data port of the aftermarket radio.
- Insert the Audio cable into the iDataLink 3.5 mm audio jack of the aftermarket radio.

STEP 5

- Connect all the harnesses to the Maestro RR module then proceed to module setup.

The module is now ready to be used.

Insert the aftermarket radio in the dashboard housing and test all the functionalities.

Reassemble the dashboard carefully.

AMPLIFIER ONLY

DETERMINE IF YOU SHOULD USE RCA'S OR LEVEL MATCHING CIRCUITS

- If your vehicle is equipped with a factory amplifier you can connect the RCA wiring to the low level outputs of your aftermarket radio, or connect the level matching circuits to the speaker outputs of the aftermarket radio.
- If your aftermarket radio does not have low level outputs, has only a single RCA output, or the RCA output level is 2 volts or less then it is recommended to connect the level matching circuit to the speaker outputs. If the volume does not go loud enough using the RCA connections, the level matching circuits can be used.
- The internal amplifier in some radios is not compatible with the level matching circuit. In these cases, there will be floor noise (hissing or buzzing at low levels) when the level matching circuit is connected. Change to the RCA connections to eliminate this noise.

TROUBLESHOOTING TIPS:

- To reset the module back its factory settings, turn the key to the OFF position then disconnect all connectors from the module. Press and hold the module's programming button and connect all the connectors back to the module. Wait, the module's LED will flash RED rapidly (this may take up to 10 seconds). Release the programming button. Wait, the LED will turn solid GREEN for 2 seconds.
- For technical assistance call 1-866-427-2999 or e-mail "support@idatalink.com". Visit us at "maestro.idatalink.com/support" and "www.12voltdata.com/forum/"

WIRING DIAGRAM *with an Amplifier*



WIRING DIAGRAM *without an Amplifier*



VEHICLE WIRE REFERENCE CHART

Wire Description	Connector Name	Connector Color	Connector Type	Position	Wire Color	Polarity	Wire Location
CanH	OBDII	~	16 pin	06	Tan/Black	(Data)	OBDII connector, under driver side dash
CanL	OBDII	~	16 pin	14	Tan	(Data)	OBDII connector, under driver side dash

RADIO WIRE REFERENCE CHART

Wire Description	Polarity	Wire Color on Maestro T-Harness	Wire Color on Alpine cable	Wire Color on Kenwood cable	Wire Color on Pioneer cable
Illumination	(+)	Orange	N/A	Orange/White	Orange/White
Reverse Light	(+)	Purple/White	Orange/White	Purple/White	Purple/White
E-Brake	(-)	Lt Green	Yellow/Blue	Lt Green	Lt Green
Foot Brake	(+)	Yellow/Black	Yellow/Black	N/A	N/A
VSS (vehicle speed sensor)	(DATA)	Pink	Green/White	N/A	Pink



INSTALL GUIDE GMC YUKON XL 2007-2011

RETAINS STEERING WHEEL CONTROLS, ONSTAR, BLUETOOTH, XM SATELLITE AND MORE!



PRODUCTS REQUIRED

iDatalink Maestro RR Radio Replacement Interface
iDatalink Maestro GM5+ Installation Harness

OPTIONAL ACCESSORIES

None

PROGRAMMED FIRMWARE

ADS-RR(SR)-GMS05-DS

NOTICE: Automotive Data Solutions Inc. (ADS) recommends having this installation performed by a certified technician. Logos and trademarks used here in are the properties of their respective owners.

WELCOME

Congratulations on the purchase of your iDatalink Maestro RR Radio replacement solution. You are now a few simple steps away from enjoying your new car radio with enhanced features.

Before starting your installation, please ensure that your iDatalink Maestro module is programmed with the correct firmware for your vehicle and that you carefully review the install guide.

Please note that Maestro RR will only retain functionalities that were originally available in the vehicle.

NEED HELP?

 **1 866 427-2999**

 support@idatalink.com

 maestro.idatalink.com/support
www.12voltdata.com/forum

TABLE OF CONTENTS

Before Installing	3
Installation Instructions	4
Wiring Diagram with an Amplifier	5
Wiring Diagram without an Amplifier	6
Vehicle Wire Reference Chart	7
Radio Wire Reference Chart	8

BEFORE INSTALLING

STEP 1

DETERMINE IF YOUR VEHICLE IS EQUIPPED WITH A FACTORY AMPLIFIER:

METHOD 1: Look for the following logos in the vehicle. They are usually on the speaker covers or on the radio unit. If you find any of the following logos Bose, Pioneer or Monsoon, you have a factory amplifier.



METHOD 2: Look for the following sticker in the glove box. This sticker will indicate all the Regular Production Option (RPO) codes. If you find any of the following codes UQA, UQS or UQG, you have a factory amplifier.

SERVICE PARTS IDENTIFICATION										DO NOT REMOVE		
2GCEK19N031344764					143 5 FXWH2Q			CKI5753				
AGI	AG2	AJ1	AL0	AM7	AN3	AU0	AU3	A31	B30	B4U		
B58	B81	B82	CJ3	C49	C7H	DF5	DK7	DL3	DT4	D07		
EVA	E63	FF8	FF9	GT5	G80	JC4	KC4	KNP	KUP	K34		
K47	K68	LQ9	M32	NCI	NEI	NP3	NP5	QCC	P30	QSS		
R4Y	R9U	R9Z	SAF	SLM	TRB	UC6	UK3	UQA	U2K	UFI		
UF3	UK3	VR4	VTV	VXS	V73	XSS	X88	YD6	YE9	YE9		
YSS	ZGC	ZYI	Z60	Z82	ISS	ISZ	4IU	6YT	691	692		
7YT												
BC/CC	U	8555				692						

STEP 2

IF YOUR VEHICLE IS EQUIPPED WITH A FACTORY AMPLIFIER:

Follow the installation instructions and complete the installation as shown in the wiring diagram **with an amplifier** and read the "AMPLIFIER ONLY" note to determine if you should use rca's or level matching circuits.

IF YOUR VEHICLE NOT IS EQUIPPED WITH A FACTORY AMPLIFIER:

Follow the installation instructions and complete the installation as shown in the wiring diagram **without an amplifier**.

INSTALLATION INSTRUCTIONS

STEP 1

- Unbox the aftermarket radio and locate its main harness.
- Connect the wires shown on the next page from aftermarket radio main harness to the GM5+ T-harness and match the wire functions.

STEP 2

- Connect the factory harness to the GM5+ T-harness.

STEP 3

- Access the OBDII connector located under the driver side dashboard.
- Connect the BROWN /RED wire of the GM5+ T-harness to the wire located at pin 6 of the OBDII connector. (See the vehicle wire chart reference for wire colors)
- Connect the BROWN /YELLOW wire of the GM5+ T-harness to the wire located at pin 14 of the OBDII connector. (See the vehicle wire chart reference for wire colors)

STEP 4

- Plug the aftermarket radio harnesses into the aftermarket radio.
- Plug the Data cable to the data port of the aftermarket radio.
- Insert the Audio cable into the iDataLink 3.5 mm audio jack of the aftermarket radio.

STEP 5

- Connect all the harnesses to the Maestro RR module then proceed to module setup.

The module is now ready to be used.

Insert the aftermarket radio in the dashboard housing and test all the functionalities.

Reassemble the dashboard carefully.

AMPLIFIER ONLY

DETERMINE IF YOU SHOULD USE RCA'S OR LEVEL MATCHING CIRCUITS

- If your vehicle is equipped with a factory amplifier you can connect the RCA wiring to the low level outputs of your aftermarket radio, or connect the level matching circuits to the speaker outputs of the aftermarket radio.
- If your aftermarket radio does not have low level outputs, has only a single RCA output, or the RCA output level is 2 volts or less then it is recommended to connect the level matching circuit to the speaker outputs. If the volume does not go loud enough using the RCA connections, the level matching circuits can be used.
- The internal amplifier in some radios is not compatible with the level matching circuit. In these cases, there will be floor noise (hissing or buzzing at low levels) when the level matching circuit is connected. Change to the RCA connections to eliminate this noise.

TROUBLESHOOTING TIPS:

- To reset the module back its factory settings, turn the key to the OFF position then disconnect all connectors from the module. Press and hold the module's programming button and connect all the connectors back to the module. Wait, the module's LED will flash RED rapidly (this may take up to 10 seconds). Release the programming button. Wait, the LED will turn solid GREEN for 2 seconds.
- For technical assistance call 1-866-427-2999 or e-mail "support@idatalink.com". Visit us at "maestro.idatalink.com/support" and "www.12voltdata.com/forum/"

WIRING DIAGRAM *with an Amplifier*



WIRING DIAGRAM *without an Amplifier*

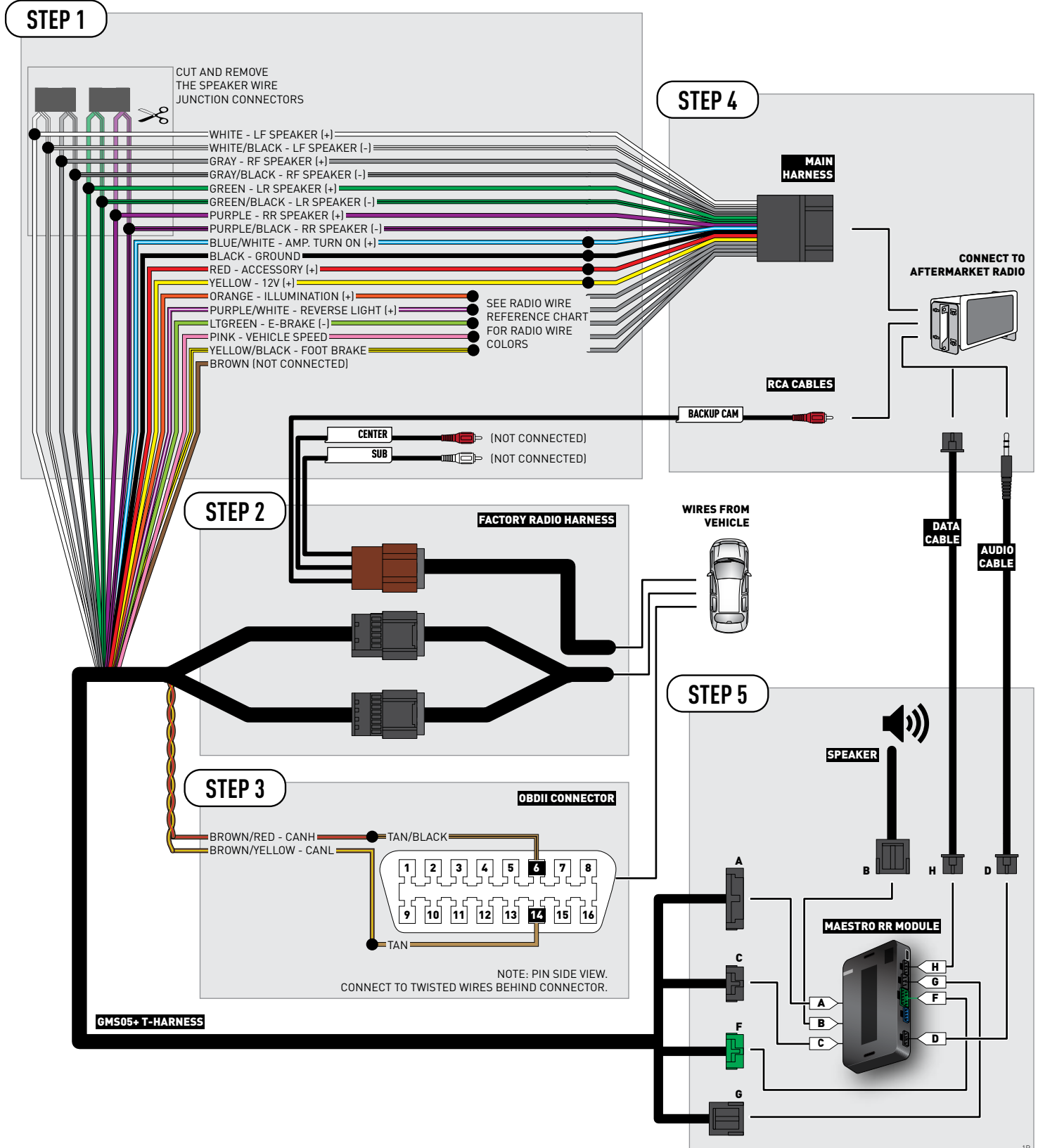

VEHICLE WIRE REFERENCE CHART

Wire Description	Connector Name	Connector Color	Connector Type	Position	Wire Color	Polarity	Wire Location
CanH	OBDII	~	16 pin	06	Tan/Black	(Data)	OBDII connector, under driver side dash
CanL	OBDII	~	16 pin	14	Tan	(Data)	OBDII connector, under driver side dash

RADIO WIRE REFERENCE CHART

Wire Description	Polarity	Wire Color on Maestro T-Harness	Wire Color on Alpine cable	Wire Color on Kenwood cable	Wire Color on Pioneer cable
Illumination	(+)	Orange	N/A	Orange/White	Orange/White
Reverse Light	(+)	Purple/White	Orange/White	Purple/White	Purple/White
E-Brake	(-)	Lt Green	Yellow/Blue	Lt Green	Lt Green
Foot Brake	(+)	Yellow/Black	Yellow/Black	N/A	N/A
VSS (vehicle speed sensor)	(DATA)	Pink	Green/White	N/A	Pink



INSTALL GUIDE GMC YUKON XL WITHOUT NAV 2012-2014

RETAINS STEERING WHEEL CONTROLS, ONSTAR, BLUETOOTH, XM SATELLITE AND MORE!



PRODUCTS REQUIRED

iDatalink Maestro RR Radio Replacement Interface
iDatalink Maestro GM5+ Installation Harness

OPTIONAL ACCESSORIES

None

PROGRAMMED FIRMWARE

ADS-RR(SR)-GMS05-DS

NOTICE: Automotive Data Solutions Inc. (ADS) recommends having this installation performed by a certified technician. Logos and trademarks used here in are the properties of their respective owners.

WELCOME

Congratulations on the purchase of your iDatalink Maestro RR Radio replacement solution. You are now a few simple steps away from enjoying your new car radio with enhanced features.

Before starting your installation, please ensure that your iDatalink Maestro module is programmed with the correct firmware for your vehicle and that you carefully review the install guide.

Please note that Maestro RR will only retain functionalities that were originally available in the vehicle.

NEED HELP?

 **1 866 427-2999**

 support@idatalink.com

 maestro.idatalink.com/support
www.12voltdata.com/forum

TABLE OF CONTENTS

Before Installing	3
Installation Instructions	4
Wiring Diagram with an Amplifier	5
Wiring Diagram without an Amplifier	6
Vehicle Wire Reference Chart	7
Radio Wire Reference Chart	8

BEFORE INSTALLING

STEP 1

DETERMINE IF YOUR VEHICLE IS EQUIPPED WITH A FACTORY AMPLIFIER:

METHOD 1: Look for the following logos in the vehicle. They are usually on the speaker covers or on the radio unit. If you find any of the following logos Bose, Pioneer or Monsoon, you have a factory amplifier.



METHOD 2: Look for the following sticker in the glove box. This sticker will indicate all the Regular Production Option (RPO) codes. If you find any of the following codes UQA, UQS or UQG, you have a factory amplifier.

SERVICE PARTS IDENTIFICATION										DO NOT REMOVE		
2GCEK19N031344764					143 5 FXWH2Q			CKI5753				
AGI	AG2	AJ1	AL0	AM7	AN3	AU0	AU3	A31	B30	B4U		
B58	B81	B82	CJ3	C49	C7H	DF5	DK7	DL3	DT4	D07		
EVA	E63	FF8	FF9	GT5	G80	JC4	KC4	KNP	KUP	K34		
K47	K68	LQ9	M32	NCI	NEI	NP3	NP5	QCC	P30	QSS		
R4Y	R9U	R9Z	SAF	SLM	TRB	UC6	UK3	UQA	U2K	UFI		
UF3	UK3	VR4	VTV	VXS	V73	XSS	X88	YD6	YE9	YE9		
YSS	ZGC	ZYI	Z60	Z82	ISS	ISZ	4IU	6YT	691	692		
7YT												
BC/CC	U	8555				692						

STEP 2

IF YOUR VEHICLE IS EQUIPPED WITH A FACTORY AMPLIFIER:

Follow the installation instructions and complete the installation as shown in the wiring diagram **with an amplifier** and read the "AMPLIFIER ONLY" note to determine if you should use rca's or level matching circuits.

IF YOUR VEHICLE NOT IS EQUIPPED WITH A FACTORY AMPLIFIER:

Follow the installation instructions and complete the installation as shown in the wiring diagram **without an amplifier**.

INSTALLATION INSTRUCTIONS

STEP 1

- Unbox the aftermarket radio and locate its main harness.
- Connect the wires shown on the next page from aftermarket radio main harness to the GM5+ T-harness and match the wire functions.

STEP 2

- Connect the factory harness to the GM5+ T-harness.

STEP 3

- Access the OBDII connector located under the driver side dashboard.
- Connect the BROWN /RED wire of the GM5+ T-harness to the wire located at pin 6 of the OBDII connector. (See the vehicle wire chart reference for wire colors)
- Connect the BROWN /YELLOW wire of the GM5+ T-harness to the wire located at pin 14 of the OBDII connector. (See the vehicle wire chart reference for wire colors)

STEP 4

- Plug the aftermarket radio harnesses into the aftermarket radio.
- Plug the Data cable to the data port of the aftermarket radio.
- Insert the Audio cable into the iDataLink 3.5 mm audio jack of the aftermarket radio.

STEP 5

- Connect all the harnesses to the Maestro RR module then proceed to module setup.

The module is now ready to be used.

Insert the aftermarket radio in the dashboard housing and test all the functionalities.

Reassemble the dashboard carefully.

AMPLIFIER ONLY

DETERMINE IF YOU SHOULD USE RCA'S OR LEVEL MATCHING CIRCUITS

- If your vehicle is equipped with a factory amplifier you can connect the RCA wiring to the low level outputs of your aftermarket radio, or connect the level matching circuits to the speaker outputs of the aftermarket radio.
- If your aftermarket radio does not have low level outputs, has only a single RCA output, or the RCA output level is 2 volts or less then it is recommended to connect the level matching circuit to the speaker outputs. If the volume does not go loud enough using the RCA connections, the level matching circuits can be used.
- The internal amplifier in some radios is not compatible with the level matching circuit. In these cases, there will be floor noise (hissing or buzzing at low levels) when the level matching circuit is connected. Change to the RCA connections to eliminate this noise.

TROUBLESHOOTING TIPS:

- To reset the module back its factory settings, turn the key to the OFF position then disconnect all connectors from the module. Press and hold the module's programming button and connect all the connectors back to the module. Wait, the module's LED will flash RED rapidly (this may take up to 10 seconds). Release the programming button. Wait, the LED will turn solid GREEN for 2 seconds.
- For technical assistance call 1-866-427-2999 or e-mail "support@idatalink.com". Visit us at "maestro.idatalink.com/support" and "www.12voltdata.com/forum/"

WIRING DIAGRAM *with an Amplifier*



WIRING DIAGRAM *without an Amplifier*

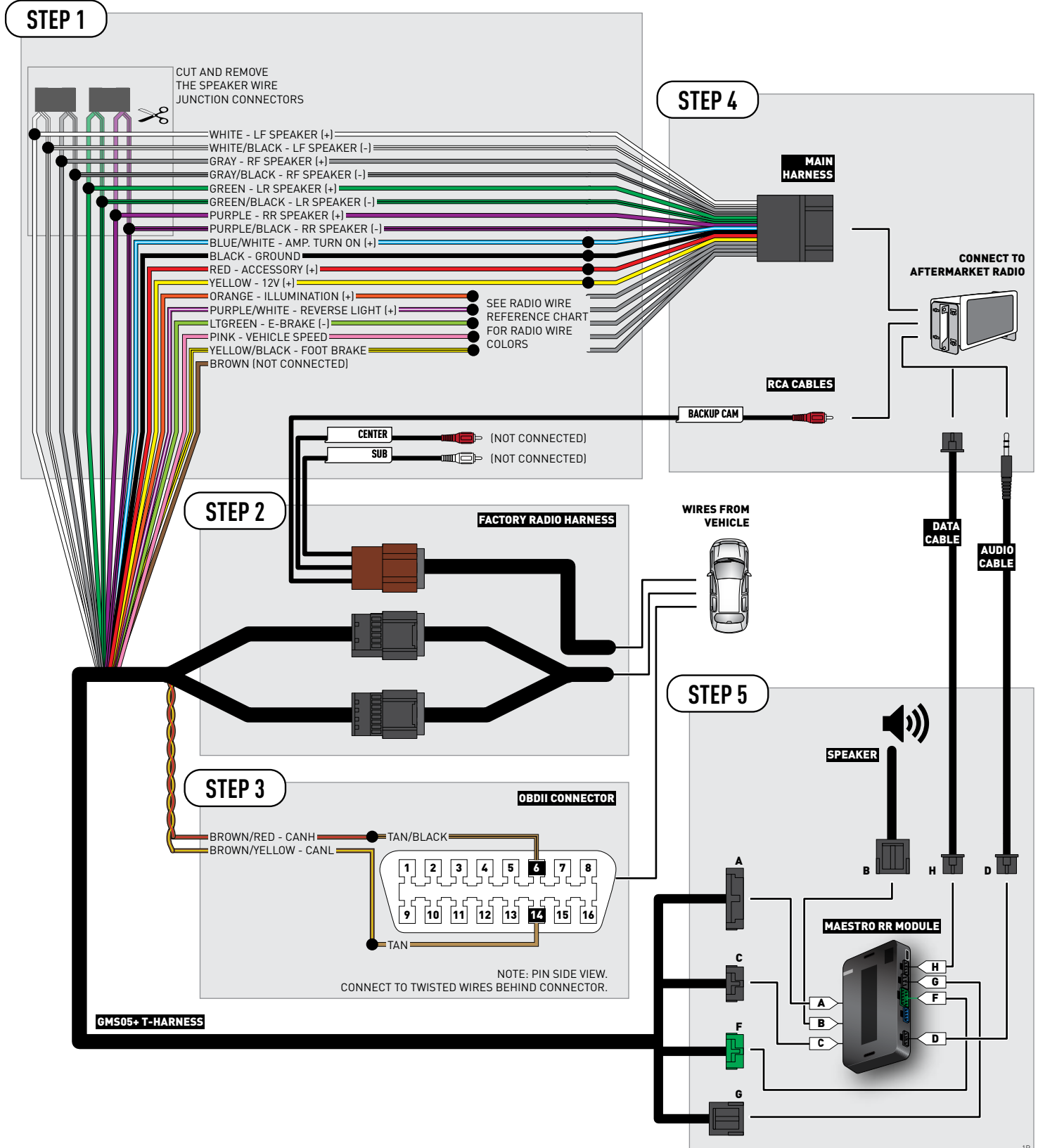

VEHICLE WIRE REFERENCE CHART

Wire Description	Connector Name	Connector Color	Connector Type	Position	Wire Color	Polarity	Wire Location
CanH	OBDII	~	16 pin	06	Tan/Black	(Data)	OBDII connector, under driver side dash
CanL	OBDII	~	16 pin	14	Tan	(Data)	OBDII connector, under driver side dash

RADIO WIRE REFERENCE CHART

Wire Description	Polarity	Wire Color on Maestro T-Harness	Wire Color on Alpine cable	Wire Color on Kenwood cable	Wire Color on Pioneer cable
Illumination	(+)	Orange	N/A	Orange/White	Orange/White
Reverse Light	(+)	Purple/White	Orange/White	Purple/White	Purple/White
E-Brake	(-)	Lt Green	Yellow/Blue	Lt Green	Lt Green
Foot Brake	(+)	Yellow/Black	Yellow/Black	N/A	N/A
VSS (vehicle speed sensor)	(DATA)	Pink	Green/White	N/A	Pink



INSTALL GUIDE HUMMER H2 2008-2009

RETAINS STEERING WHEEL CONTROLS, ONSTAR, BLUETOOTH, XM SATELLITE AND MORE!



PRODUCTS REQUIRED

iDatalink Maestro RR Radio Replacement Interface
iDatalink Maestro GM5+ Installation Harness

OPTIONAL ACCESSORIES

None

PROGRAMMED FIRMWARE

ADS-RR(SR)-GMS05-DS

NOTICE: Automotive Data Solutions Inc. (ADS) recommends having this installation performed by a certified technician. Logos and trademarks used here in are the properties of their respective owners.

WELCOME

Congratulations on the purchase of your iDatalink Maestro RR Radio replacement solution. You are now a few simple steps away from enjoying your new car radio with enhanced features.

Before starting your installation, please ensure that your iDatalink Maestro module is programmed with the correct firmware for your vehicle and that you carefully review the install guide.

Please note that Maestro RR will only retain functionalities that were originally available in the vehicle.

NEED HELP?

 **1 866 427-2999**

 support@idatalink.com

 maestro.idatalink.com/support
www.12voltdata.com/forum

TABLE OF CONTENTS

Before Installing	3
Installation Instructions	4
Wiring Diagram with an Amplifier	5
Wiring Diagram without an Amplifier	6
Vehicle Wire Reference Chart	7
Radio Wire Reference Chart	8

BEFORE INSTALLING

STEP 1

DETERMINE IF YOUR VEHICLE IS EQUIPPED WITH A FACTORY AMPLIFIER:

METHOD 1: Look for the following logos in the vehicle. They are usually on the speaker covers or on the radio unit. If you find any of the following logos Bose, Pioneer or Monsoon, you have a factory amplifier.



METHOD 2: Look for the following sticker in the glove box. This sticker will indicate all the Regular Production Option (RPO) codes. If you find any of the following codes UQA, UQS or UQG, you have a factory amplifier.

SERVICE PARTS IDENTIFICATION												DO NOT REMOVE	
2GCEK19N031344764						143 5 FXWH2Q			CKI5753				
AGI	AG2	AJ1	AL0	AM7	AN3	AU0	AU3	A31	B30	B4U			
B58	B81	B82	CJ3	C49	C7H	DF5	DK7	DL3	DT4	D07			
EVA	E63	FF8	FF9	GT5	G80	JC4	KC4	KNP	KUP	K34			
K47	K68	LQ9	M32	NCI	NEI	NP3	NP5	QCC	P30	QSS			
R4Y	R9U	R9Z	SAF	SLM	TRB	UC6	UK3	UQA	U2K	UFI			
UF3	UK3	VR4	VTV	VXS	V73	XSS	X88	YD6	YE9				
YSS	ZGC	ZYI	Z60	Z82	ISS	ISZ	4IU	6YT	691	692			
7YT													
BC/CC	U	8555				692							

STEP 2

IF YOUR VEHICLE IS EQUIPPED WITH A FACTORY AMPLIFIER:

Follow the installation instructions and complete the installation as shown in the wiring diagram **with an amplifier** and read the "AMPLIFIER ONLY" note to determine if you should use rca's or level matching circuits.

IF YOUR VEHICLE NOT IS EQUIPPED WITH A FACTORY AMPLIFIER:

Follow the installation instructions and complete the installation as shown in the wiring diagram **without an amplifier**.

INSTALLATION INSTRUCTIONS

STEP 1

- Unbox the aftermarket radio and locate its main harness.
- Connect the wires shown on the next page from aftermarket radio main harness to the GM5+ T-harness and match the wire functions.

STEP 2

- Connect the factory harness to the GM5+ T-harness.

STEP 3

- Access the OBDII connector located under the driver side dashboard.
- Connect the BROWN /RED wire of the GM5+ T-harness to the wire located at pin 6 of the OBDII connector. (See the vehicle wire chart reference for wire colors)
- Connect the BROWN /YELLOW wire of the GM5+ T-harness to the wire located at pin 14 of the OBDII connector. (See the vehicle wire chart reference for wire colors)

STEP 4

- Plug the aftermarket radio harnesses into the aftermarket radio.
- Plug the Data cable to the data port of the aftermarket radio.
- Insert the Audio cable into the iDatalink 3.5 mm audio jack of the aftermarket radio.

STEP 5

- Connect all the harnesses to the Maestro RR module then proceed to module setup.

The module is now ready to be used.

Insert the aftermarket radio in the dashboard housing and test all the functionalities.

Reassemble the dashboard carefully.

AMPLIFIER ONLY

DETERMINE IF YOU SHOULD USE RCA'S OR LEVEL MATCHING CIRCUITS

- If your vehicle is equipped with a factory amplifier you can connect the RCA wiring to the low level outputs of your aftermarket radio, or connect the level matching circuits to the speaker outputs of the aftermarket radio.
- If your aftermarket radio does not have low level outputs, has only a single RCA output, or the RCA output level is 2 volts or less then it is recommended to connect the level matching circuit to the speaker outputs. If the volume does not go loud enough using the RCA connections, the level matching circuits can be used.
- The internal amplifier in some radios is not compatible with the level matching circuit. In these cases, there will be floor noise (hissing or buzzing at low levels) when the level matching circuit is connected. Change to the RCA connections to eliminate this noise.

TROUBLESHOOTING TIPS:

- To reset the module back its factory settings, turn the key to the OFF position then disconnect all connectors from the module. Press and hold the module's programming button and connect all the connectors back to the module. Wait, the module's LED will flash RED rapidly (this may take up to 10 seconds). Release the programming button. Wait, the LED will turn solid GREEN for 2 seconds.
- For technical assistance call 1-866-427-2999 or e-mail "support@idatalink.com". Visit us at "maestro.idatalink.com/support" and "www.12voltdata.com/forum/"

WIRING DIAGRAM *with an Amplifier*



WIRING DIAGRAM *without an Amplifier*

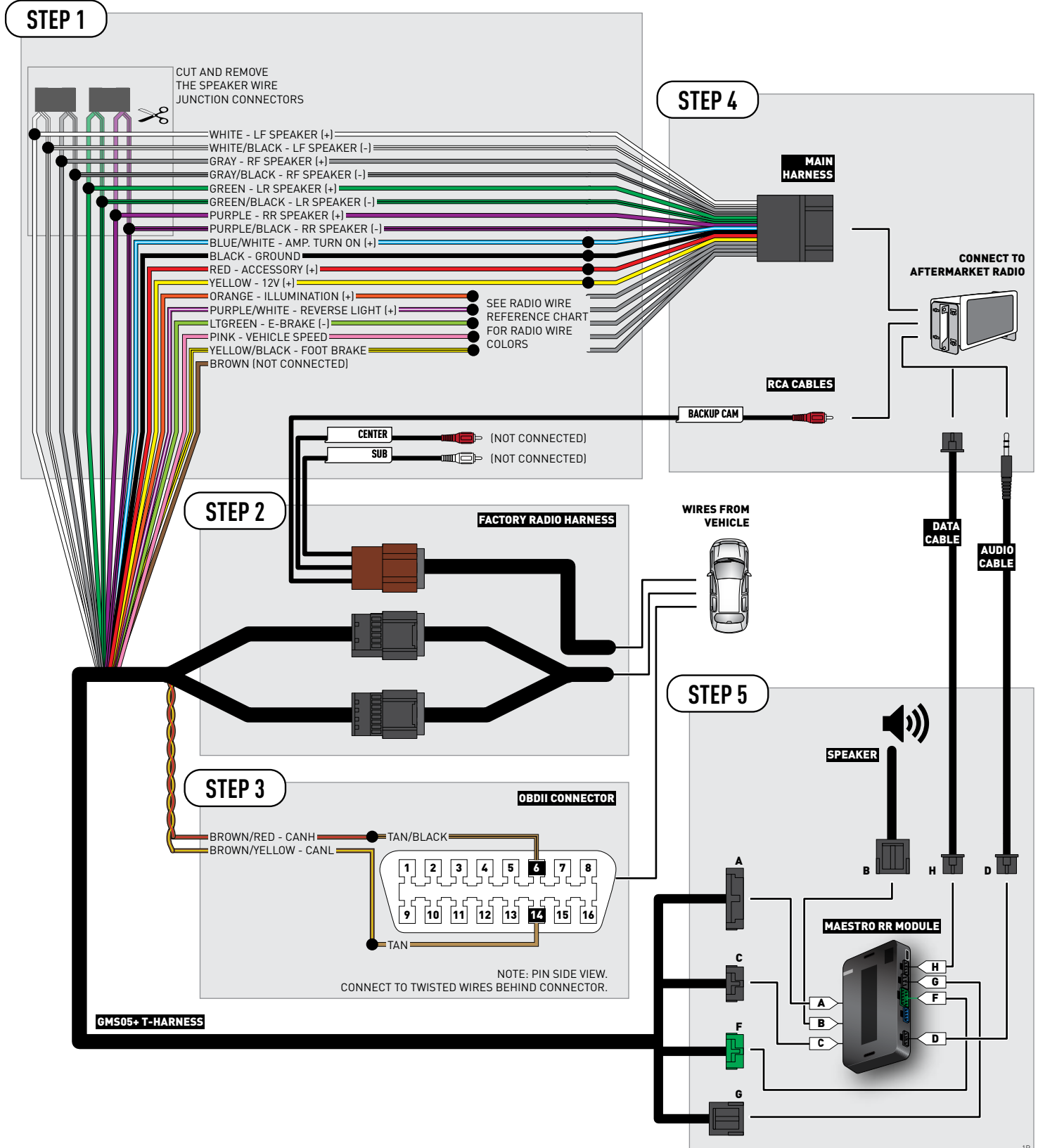

VEHICLE WIRE REFERENCE CHART

Wire Description	Connector Name	Connector Color	Connector Type	Position	Wire Color	Polarity	Wire Location
CanH	OBDII	~	16 pin	06	Tan/Black	(Data)	OBDII connector, under driver side dash
CanL	OBDII	~	16 pin	14	Tan	(Data)	OBDII connector, under driver side dash

RADIO WIRE REFERENCE CHART

Wire Description	Polarity	Wire Color on Maestro T-Harness	Wire Color on Alpine cable	Wire Color on Kenwood cable	Wire Color on Pioneer cable
Illumination	(+)	Orange	N/A	Orange/White	Orange/White
Reverse Light	(+)	Purple/White	Orange/White	Purple/White	Purple/White
E-Brake	(-)	Lt Green	Yellow/Blue	Lt Green	Lt Green
Foot Brake	(+)	Yellow/Black	Yellow/Black	N/A	N/A
VSS (vehicle speed sensor)	(DATA)	Pink	Green/White	N/A	Pink



INSTALL GUIDE SATURN OUTLOOK 2007-2010

RETAINS STEERING WHEEL CONTROLS, ONSTAR, BLUETOOTH, XM SATELLITE AND MORE!



PRODUCTS REQUIRED

iDatalink Maestro RR Radio Replacement Interface
iDatalink Maestro GM5+ Installation Harness

OPTIONAL ACCESSORIES

None

PROGRAMMED FIRMWARE

ADS-RR(SR)-GMS05-DS

NOTICE: Automotive Data Solutions Inc. (ADS) recommends having this installation performed by a certified technician. Logos and trademarks used here in are the properties of their respective owners.

WELCOME

Congratulations on the purchase of your iDatalink Maestro RR Radio replacement solution. You are now a few simple steps away from enjoying your new car radio with enhanced features.

Before starting your installation, please ensure that your iDatalink Maestro module is programmed with the correct firmware for your vehicle and that you carefully review the install guide.

Please note that Maestro RR will only retain functionalities that were originally available in the vehicle.

NEED HELP?

 **1 866 427-2999**

 support@idatalink.com

 maestro.idatalink.com/support
www.12voltdata.com/forum

TABLE OF CONTENTS

Before Installing	3
Installation Instructions	4
Wiring Diagram with an Amplifier	5
Wiring Diagram without an Amplifier	6
Vehicle Wire Reference Chart	7
Radio Wire Reference Chart	8

BEFORE INSTALLING

STEP 1

DETERMINE IF YOUR VEHICLE IS EQUIPPED WITH A FACTORY AMPLIFIER:

METHOD 1: Look for the following logos in the vehicle. They are usually on the speaker covers or on the radio unit. If you find any of the following logos Bose, Pioneer or Monsoon, you have a factory amplifier.



METHOD 2: Look for the following sticker in the glove box. This sticker will indicate all the Regular Production Option (RPO) codes. If you find any of the following codes UQA, UQS or UQG, you have a factory amplifier.

SERVICE PARTS IDENTIFICATION												DO NOT REMOVE	
2GCEK19N031344764						143 5 FXWH2Q			CKI5753				
AGI	AG2	AJ1	AL0	AM7	AN3	AU0	AU3	A31	B30	B4U			
B58	B81	B82	CJ3	C49	C7H	DF5	DK7	DL3	DT4	D07			
EVA	E63	FF8	FF9	GT5	G80	JC4	KC4	KNP	KUP	K34			
K47	K68	LQ9	M32	NCI	NEI	NP3	NP5	QCC	P30	QSS			
R4Y	R9U	R9Z	SAF	SLM	TRB	UC6	UK3	UQA	U2K	UFI			
UF3	UK3	VR4	VTV	VXS	V73	XSS	X88	YD6	YD6	YE9			
YSS	ZGC	ZYI	Z60	Z82	ISS	ISZ	4IU	6YT	691	692			
7YT													
BC/CC	U	8555				692							

STEP 2

IF YOUR VEHICLE IS EQUIPPED WITH A FACTORY AMPLIFIER:

Follow the installation instructions and complete the installation as shown in the wiring diagram **with an amplifier** and read the "AMPLIFIER ONLY" note to determine if you should use rca's or level matching circuits.

IF YOUR VEHICLE NOT IS EQUIPPED WITH A FACTORY AMPLIFIER:

Follow the installation instructions and complete the installation as shown in the wiring diagram **without an amplifier**.

INSTALLATION INSTRUCTIONS

STEP 1

- Unbox the aftermarket radio and locate its main harness.
- Connect the wires shown on the next page from aftermarket radio main harness to the GM5+ T-harness and match the wire functions.

STEP 2

- Connect the factory harness to the GM5+ T-harness.

STEP 3

- Access the OBDII connector located under the driver side dashboard.
- Connect the BROWN /RED wire of the GM5+ T-harness to the wire located at pin 6 of the OBDII connector. (See the vehicle wire chart reference for wire colors)
- Connect the BROWN /YELLOW wire of the GM5+ T-harness to the wire located at pin 14 of the OBDII connector. (See the vehicle wire chart reference for wire colors)

STEP 4

- Plug the aftermarket radio harnesses into the aftermarket radio.
- Plug the Data cable to the data port of the aftermarket radio.
- Insert the Audio cable into the iDataLink 3.5 mm audio jack of the aftermarket radio.

STEP 5

- Connect all the harnesses to the Maestro RR module then proceed to module setup.

The module is now ready to be used.

Insert the aftermarket radio in the dashboard housing and test all the functionalities.

Reassemble the dashboard carefully.

AMPLIFIER ONLY

DETERMINE IF YOU SHOULD USE RCA'S OR LEVEL MATCHING CIRCUITS

- If your vehicle is equipped with a factory amplifier you can connect the RCA wiring to the low level outputs of your aftermarket radio, or connect the level matching circuits to the speaker outputs of the aftermarket radio.
- If your aftermarket radio does not have low level outputs, has only a single RCA output, or the RCA output level is 2 volts or less then it is recommended to connect the level matching circuit to the speaker outputs. If the volume does not go loud enough using the RCA connections, the level matching circuits can be used.
- The internal amplifier in some radios is not compatible with the level matching circuit. In these cases, there will be floor noise (hissing or buzzing at low levels) when the level matching circuit is connected. Change to the RCA connections to eliminate this noise.

TROUBLESHOOTING TIPS:

- To reset the module back its factory settings, turn the key to the OFF position then disconnect all connectors from the module. Press and hold the module's programming button and connect all the connectors back to the module. Wait, the module's LED will flash RED rapidly (this may take up to 10 seconds). Release the programming button. Wait, the LED will turn solid GREEN for 2 seconds.
- For technical assistance call 1-866-427-2999 or e-mail "support@idatalink.com". Visit us at "maestro.idatalink.com/support" and "www.12voltdata.com/forum/"

WIRING DIAGRAM *with an Amplifier*



WIRING DIAGRAM *without an Amplifier*



VEHICLE WIRE REFERENCE CHART

Wire Description	Connector Name	Connector Color	Connector Type	Position	Wire Color	Polarity	Wire Location
CanH	OBDII	~	16 pin	06	Tan/Black	(Data)	OBDII connector, under driver side dash
CanL	OBDII	~	16 pin	14	Tan	(Data)	OBDII connector, under driver side dash

RADIO WIRE REFERENCE CHART

Wire Description	Polarity	Wire Color on Maestro T-Harness	Wire Color on Alpine cable	Wire Color on Kenwood cable	Wire Color on Pioneer cable
Illumination	(+)	Orange	N/A	Orange/White	Orange/White
Reverse Light	(+)	Purple/White	Orange/White	Purple/White	Purple/White
E-Brake	(-)	Lt Green	Yellow/Blue	Lt Green	Lt Green
Foot Brake	(+)	Yellow/Black	Yellow/Black	N/A	N/A
VSS (vehicle speed sensor)	(DATA)	Pink	Green/White	N/A	Pink