



HOW TO USE THIS INSTALL GUIDE

- 1** Open the Bookmarks menu and find your vehicle OR scroll down until you find the install guide for your vehicle.
- 2** Print only the pages for your vehicle using the advanced options in the Print menu.
- 3** Install your Maestro RR according to the guide for your vehicle.

WARNING

Pressing the printer icon or “quick printing” this document will print all of the guides in this compilation.



INSTALL GUIDE

CHEVROLET COLORADO

2015-2017

RETAINS STEERING WHEEL CONTROLS, ONSTAR, AND MORE!



PRODUCTS REQUIRED

iDatalink Maestro RR Radio Replacement Interface
iDatalink Maestro GM3 Installation Harness

OPTIONAL ACCESSORIES

None

PROGRAMMED FIRMWARE

ADS-RR(SR)-GMS03-DS

NOTICE: Automotive Data Solutions Inc. (ADS) recommends having this installation performed by a certified technician. Logos and trademarks used here in are the properties of their respective owners.

WELCOME

Congratulations on the purchase of your iDatalink Maestro RR Radio replacement solution. You are now a few simple steps away from enjoying your new car radio with enhanced features.

Before starting your installation, please ensure that your iDatalink Maestro module is programmed with the correct firmware for your vehicle and that you carefully review the install guide.

Please note that Maestro RR will only retain functionalities that were originally available in the vehicle.

NEED HELP?

 **1 866 427-2999**

 support@idatalink.com

 maestro.idatalink.com/support
www.12voltdata.com/forum

TABLE OF CONTENTS

Installation Instructions	3
Wiring Diagram without an Amplifier	4
Wiring Diagram with an Amplifier	5
Radio Wire Reference Chart	6
Vehicle Wire Reference Chart	7

INSTALLATION INSTRUCTIONS

BEFORE INSTALLING

- Determine if the vehicle has a Bose amplifier. Look for badges on the radio, door panels, and dash that indicate that the vehicle has Bose.

If the vehicle DOES NOT have a factory amplifier:

complete the installation as shown in the wiring diagram **without an amplifier**.

If the vehicle DOES have a factory amplifier:

complete the installation as shown in the wiring diagram **with an amplifier**. The amplifier cannot be retained; it must be bypassed or replaced with an aftermarket amplifier. See the vehicle reference chart for wire colors; bypass instructions are not included.

- Remove the factory radio.

STEP 1

- Unbox the aftermarket radio and locate its main harness.
- Refer to the wiring diagram and connect the wires from aftermarket radio main harness to the GM3 T-harness and match the wire functions.

STEP 2

- If the vehicle is equipped with an OEM backup camera, connect the backup camera harness to the Human Machine Interface module harness, located at the bottom of the radio cavity. Note: The guide lines of the backup camera will not be retained.

STEP 3

- Connect the factory harness to the GM3 T-harness.

STEP 4

Plug the climate control portion of the GM3 T-harness into the climate controls.

STEP 5

- Plug the male BLACK 3 pin connector of your GM3 T-harness into the OBDII/SW control harness.

- Plug the OBDII connector into the OBDII of the vehicle.

STEP 6

If the vehicle DOES have steering wheel controls:

- Remove steering column shroud.
- Locate the steering wheel control wire in the GM3 steering wheel harness. Cut the GREEN/BLACK wire and splice it into pin 9.
- Plug the steering wheel control T-harness into the harness at the steering wheel (steering wheel connector located at top of steering column).

STEP 7

- Plug the aftermarket radio harnesses into the aftermarket radio.
- Connect the backup camera RCA cable harness into the aftermarket radio.
- Plug the Data cable to the data port of the aftermarket radio.
- Insert the Audio cable into the iDatalink 3.5 mm audio jack of the aftermarket radio.

STEP 8

- Connect all the harnesses to the Maestro RR module then proceed test your installation.

TROUBLESHOOTING TIPS:

- To reset the module back its factory settings, turn the key to the OFF position then disconnect all connectors from the module. Press and hold the module's programming button and connect all the connectors back to the module. Wait, the module's LED will flash RED rapidly (this may take up to 10 seconds). Release the programming button. Wait, the LED will turn solid GREEN for 2 seconds.
- For technical assistance call 1-866-427-2999 or e-mail "support@idatalink.com". Visit us at "maestro.idatalink.com/support" and "www.12voltdata.com/forum/"

WIRING DIAGRAM *without an Amplifier*

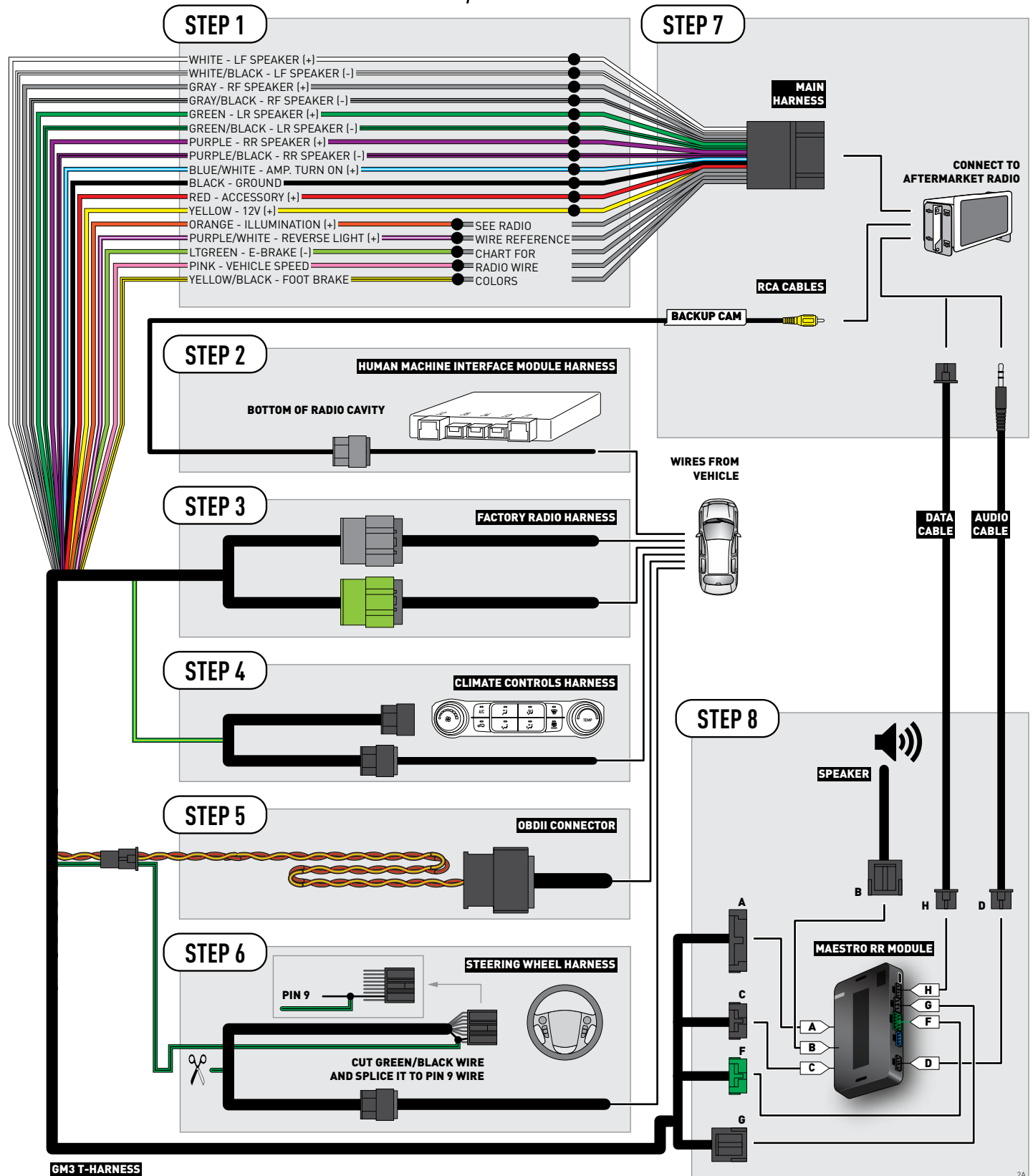

WIRING DIAGRAM *with an Amplifier*

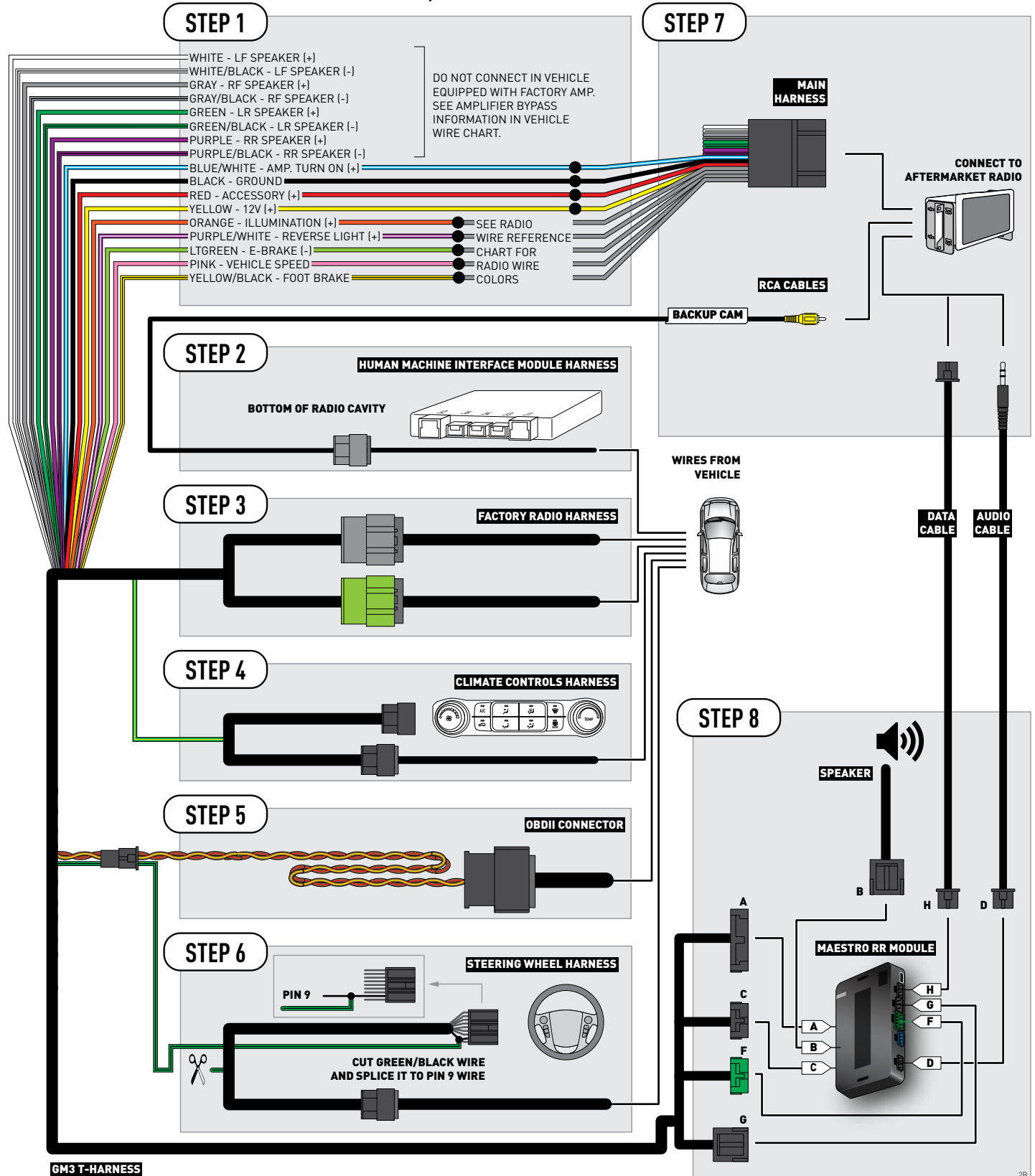

RADIO WIRE REFERENCE CHART

Wire Description	Polarity	Wire Color on Maestro T-Harness	Wire Color on Alpine cable	Wire Color on Kenwood cable	Wire Color on Pioneer cable
Illumination	(+)	Orange	N/A	Orange/White	Orange/White
Reverse Light	(+)	Purple/White	Orange/White	Purple/White	Purple/White
E-Brake	(-)	Lt Green	Yellow/Blue	Lt Green	Lt Green
Foot Brake	(+)	Yellow/Black	Yellow/Black	N/A	N/A
VSS (vehicle speed sensor)	(DATA)	Pink	Green/White	N/A	Pink

VEHICLE WIRE REFERENCE CHART

Wire Description	Connector Name	Connector Color	Connector Type	Position	Wire Color	Polarity	Wire Location
Subwoofer	~	~	8 pin	01	DkBlue/Gray	(+)	Amplifier, in dashboard, to the right of the glove box
Subwoofer	~	~	8 pin	05	Gray/Black	(-)	Amplifier, in dashboard, to the right of the glove box
RF Speaker	~	~	8 pin	02	Yellow	(+)	Amplifier, in dashboard, to the right of the glove box
RF Speaker	~	~	8 pin	06	Yellow/Black	(-)	Amplifier, in dashboard, to the right of the glove box
LF Speaker	~	~	8 pin	03	DkBlue	(+)	Amplifier, in dashboard, to the right of the glove box
LF Speaker	~	~	8 pin	07	Brown/DkBlue	(-)	Amplifier, in dashboard, to the right of the glove box
RF Tweeter (if equipped)	~	~	16 pin	04	Brown/LtGreen	(+)	Amplifier, in dashboard, to the right of the glove box
RF Tweeter (if equipped)	~	~	16 pin	12	Purple/Brown	(-)	Amplifier, in dashboard, to the right of the glove box
LF Tweeter (if equipped)	~	~	16 pin	05	Yellow/DkBlue	(+)	Amplifier, in dashboard, to the right of the glove box
LF Tweeter (if equipped)	~	~	16 pin	13	Yellow/Gray	(-)	Amplifier, in dashboard, to the right of the glove box
RR Speaker	~	~	16 pin	06	White	(+)	Amplifier, in dashboard, to the right of the glove box
RR Speaker	~	~	16 pin	14	DkBlue/Black	(-)	Amplifier, in dashboard, to the right of the glove box
LR Speaker	~	~	16 pin	07	LtGreen	(+)	Amplifier, in dashboard, to the right of the glove box
LR Speaker	~	~	16 pin	15	LtGreen/Black	(-)	Amplifier, in dashboard, to the right of the glove box

AMPLIFIER CONNECTORS (WIRE SIDE)

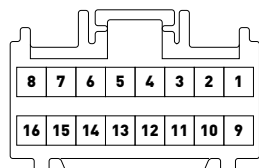
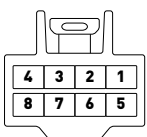



INSTALL GUIDE

CHEVROLET SILVERADO 1500

WITH 4.2" AND 8" RADIOS

2014-2017

RETAINS STEERING WHEEL CONTROLS, ONSTAR, AND MORE!



PRODUCTS REQUIRED

iDatalink Maestro RR Radio Replacement Interface
iDatalink Maestro GM3 Installation Harness

OPTIONAL ACCESSORIES

None

PROGRAMMED FIRMWARE

ADS-RR(SR)-GMS03-DS

NOTICE: Automotive Data Solutions Inc. (ADS) recommends having this installation performed by a certified technician. Logos and trademarks used here in are the properties of their respective owners.

WELCOME

Congratulations on the purchase of your iDatalink Maestro RR Radio replacement solution. You are now a few simple steps away from enjoying your new car radio with enhanced features.

Before starting your installation, please ensure that your iDatalink Maestro module is programmed with the correct firmware for your vehicle and that you carefully review the install guide.

Please note that Maestro RR will only retain functionalities that were originally available in the vehicle.

TABLE OF CONTENTS

Installation Instructions	3
Wiring Diagram without an Amplifier	4
Wiring Diagram with an Amplifier	5
Radio Wire Reference Chart	6
Vehicle Wire Reference Chart	7

NEED HELP?

 **1 866 427-2999**

 support@idatalink.com

 maestro.idatalink.com/support
www.12voltdata.com/forum

INSTALLATION INSTRUCTIONS

BEFORE INSTALLING

- Determine if the vehicle has a Bose amplifier. Look for badges on the radio, door panels, and dash that indicate that the vehicle has Bose.

If the vehicle DOES NOT have a factory amplifier:

complete the installation as shown in the wiring diagram **without an amplifier.**

If the vehicle DOES have a factory amplifier:

complete the installation as shown in the wiring diagram **with an amplifier.** The amplifier cannot be retained; it must be bypassed or replaced with an aftermarket amplifier. See the vehicle reference chart for wire colors; bypass instructions are not included.

- Remove the factory radio.

STEP 1

- Unbox the aftermarket radio and locate its main harness.
- Refer to the wiring diagram and connect the wires from aftermarket radio main harness to the GM3 T-harness and match the wire functions.

STEP 2

- If the vehicle is equipped with an OEM backup camera, connect the backup camera harness to the Human Machine Interface module harness, located behind the glove box. Note: The guide lines of the backup camera will not be retained.

STEP 3

- Connect the factory harness to the GM3 T-harness.

STEP 4

Plug the climate control portion of the GM3 T-harness into the climate controls.

STEP 5

- Plug the male BLACK 3 pin connector of your GM3 T-harness into the OBDII/SW control harness.

- Plug the OBDII connector into the OBDII of the vehicle.

STEP 6

- Remove steering column shroud.
- Plug the steering wheel control T-harness into the harness at the steering wheel (steering wheel connector located at bottom of steering column).

STEP 7

- Plug the aftermarket radio harnesses into the aftermarket radio.
- Connect the backup camera RCA cable harness into the aftermarket radio.
- Plug the Data cable to the data port of the aftermarket radio.
- Insert the Audio cable into the iDatalink 3.5 mm audio jack of the aftermarket radio.

STEP 8

- Connect all the harnesses to the Maestro RR module then proceed test your installation.

TROUBLESHOOTING TIPS:

- To reset the module back its factory settings, turn the key to the OFF position then disconnect all connectors from the module. Press and hold the module's programming button and connect all the connectors back to the module. Wait, the module's LED will flash RED rapidly (this may take up to 10 seconds). Release the programming button. Wait, the LED will turn solid GREEN for 2 seconds.
- For technical assistance call 1-866-427-2999 or e-mail "support@idatalink.com". Visit us at "maestro.idatalink.com/support" and "www.12voltdata.com/forum/"

WIRING DIAGRAM *without an Amplifier*

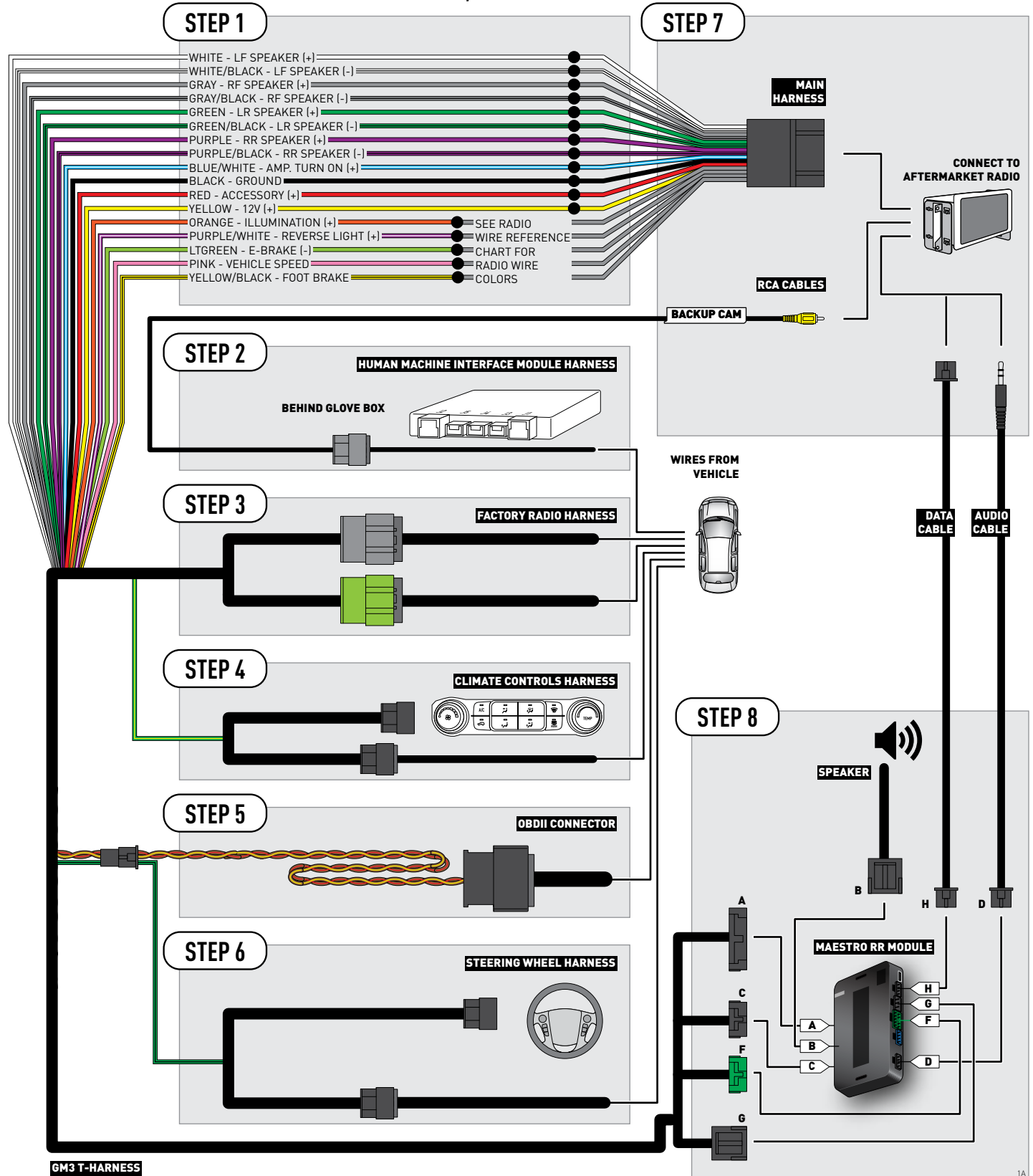

WIRING DIAGRAM *with an Amplifier*

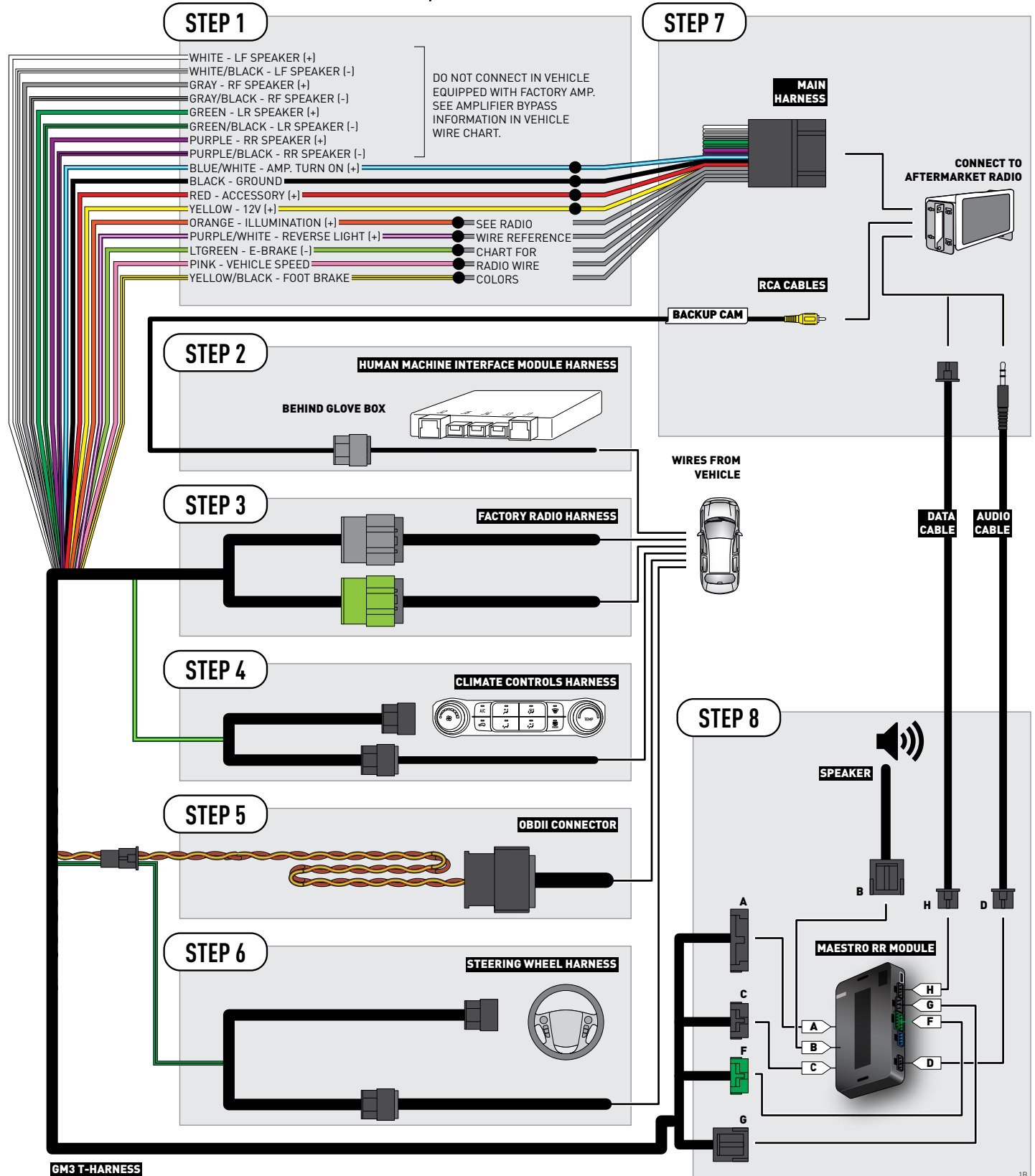

RADIO WIRE REFERENCE CHART

Wire Description	Polarity	Wire Color on Maestro T-Harness	Wire Color on Alpine cable	Wire Color on Kenwood cable	Wire Color on Pioneer cable
Illumination	(+)	Orange	N/A	Orange/White	Orange/White
Reverse Light	(+)	Purple/White	Orange/White	Purple/White	Purple/White
E-Brake	(-)	Lt Green	Yellow/Blue	Lt Green	Lt Green
Foot Brake	(+)	Yellow/Black	Yellow/Black	N/A	N/A
VSS (vehicle speed sensor)	(DATA)	Pink	Green/White	N/A	Pink

VEHICLE WIRE REFERENCE CHART

Wire Description	Connector Name	Connector Color	Connector Type	Position	Wire Color	Polarity	Wire Location
Subwoofer	~	~	8 pin	01	DkBlue/Gray	(+)	Amplifier, back wall of the cab, center of the wall
Subwoofer	~	~	8 pin	05	Gray/Black	(-)	Amplifier, back wall of the cab, center of the wall
RF Speaker	~	~	8 pin	02	Yellow	(+)	Amplifier, back wall of the cab, center of the wall
RF Speaker	~	~	8 pin	06	Yellow/Black	(-)	Amplifier, back wall of the cab, center of the wall
LF Speaker	~	~	8 pin	03	DkBlue	(+)	Amplifier, back wall of the cab, center of the wall
LF Speaker	~	~	8 pin	07	Brown/DkBlue	(-)	Amplifier, back wall of the cab, center of the wall
RF Tweeter (if equipped)	~	~	16 pin	04	Brown/LtGreen	(+)	Amplifier, back wall of the cab, center of the wall
RF Tweeter (if equipped)	~	~	16 pin	12	Purple/Brown	(-)	Amplifier, back wall of the cab, center of the wall
LF Tweeter (if equipped)	~	~	16 pin	05	Yellow/DkBlue	(+)	Amplifier, back wall of the cab, center of the wall
LF Tweeter (if equipped)	~	~	16 pin	13	Yellow/Gray	(-)	Amplifier, back wall of the cab, center of the wall
RR Speaker	~	~	16 pin	06	White	(+)	Amplifier, back wall of the cab, center of the wall
RR Speaker	~	~	16 pin	14	DkBlue/Black	(-)	Amplifier, back wall of the cab, center of the wall
LR Speaker	~	~	16 pin	07	LtGreen	(+)	Amplifier, back wall of the cab, center of the wall
LR Speaker	~	~	16 pin	15	LtGreen/Black	(-)	Amplifier, back wall of the cab, center of the wall

AMPLIFIER CONNECTORS (WIRE SIDE)

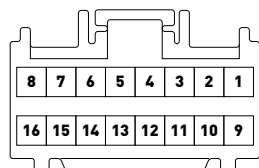
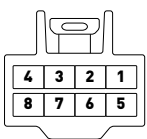



INSTALL GUIDE

CHEVROLET SILVERADO 2500 & 3500

WITH 4.2" AND 8" RADIOS

2015-2017

RETAINS STEERING WHEEL CONTROLS, ONSTAR, AND MORE!



PRODUCTS REQUIRED

iDatalink Maestro RR Radio Replacement Interface
iDatalink Maestro GM3 Installation Harness

OPTIONAL ACCESSORIES

None

PROGRAMMED FIRMWARE

ADS-RR(SR)-GMS03-DS

NOTICE: Automotive Data Solutions Inc. (ADS) recommends having this installation performed by a certified technician. Logos and trademarks used here in are the properties of their respective owners.

WELCOME

Congratulations on the purchase of your iDatalink Maestro RR Radio replacement solution. You are now a few simple steps away from enjoying your new car radio with enhanced features.

Before starting your installation, please ensure that your iDatalink Maestro module is programmed with the correct firmware for your vehicle and that you carefully review the install guide.

Please note that Maestro RR will only retain functionalities that were originally available in the vehicle.

NEED HELP?

 **1 866 427-2999**

 support@idatalink.com

 maestro.idatalink.com/support
www.12voltdata.com/forum

TABLE OF CONTENTS

Installation Instructions	3
Wiring Diagram without an Amplifier	4
Wiring Diagram with an Amplifier	5
Radio Wire Reference Chart	6
Vehicle Wire Reference Chart	7

INSTALLATION INSTRUCTIONS

BEFORE INSTALLING

- Determine if the vehicle has a Bose amplifier. Look for badges on the radio, door panels, and dash that indicate that the vehicle has Bose.

If the vehicle DOES NOT have a factory amplifier:

complete the installation as shown in the wiring diagram **without an amplifier**.

If the vehicle DOES have a factory amplifier:

complete the installation as shown in the wiring diagram **with an amplifier**. The amplifier cannot be retained; it must be bypassed or replaced with an aftermarket amplifier. See the vehicle reference chart for wire colors; bypass instructions are not included.

- Remove the factory radio.

STEP 1

- Unbox the aftermarket radio and locate its main harness.
- Refer to the wiring diagram and connect the wires from aftermarket radio main harness to the GM3 T-harness and match the wire functions.

STEP 2

- If the vehicle is equipped with an OEM backup camera, connect the backup camera harness to the Human Machine Interface module harness, located behind the glove box. Note: The guide lines of the backup camera will not be retained.

STEP 3

- Connect the factory harness to the GM3 T-harness.

STEP 4

Plug the climate control portion of the GM3 T-harness into the climate controls.

STEP 5

- Plug the male BLACK 3 pin connector of your GM3 T-harness into the OBDII/SW control harness.

- Plug the OBDII connector into the OBDII of the vehicle.

STEP 6

- Remove steering column shroud.
- Plug the steering wheel control T-harness into the harness at the steering wheel (steering wheel connector located at bottom of steering column).

STEP 7

- Plug the aftermarket radio harnesses into the aftermarket radio.
- Connect the backup camera RCA cable harness into the aftermarket radio.
- Plug the Data cable to the data port of the aftermarket radio.
- Insert the Audio cable into the iDatalink 3.5 mm audio jack of the aftermarket radio.

STEP 8

- Connect all the harnesses to the Maestro RR module then proceed test your installation.

TROUBLESHOOTING TIPS:

- To reset the module back its factory settings, turn the key to the OFF position then disconnect all connectors from the module. Press and hold the module's programming button and connect all the connectors back to the module. Wait, the module's LED will flash RED rapidly (this may take up to 10 seconds). Release the programming button. Wait, the LED will turn solid GREEN for 2 seconds.
- For technical assistance call 1-866-427-2999 or e-mail "support@idatalink.com". Visit us at "maestro.idatalink.com/support" and "www.12voltdata.com/forum/"

WIRING DIAGRAM *without an Amplifier*

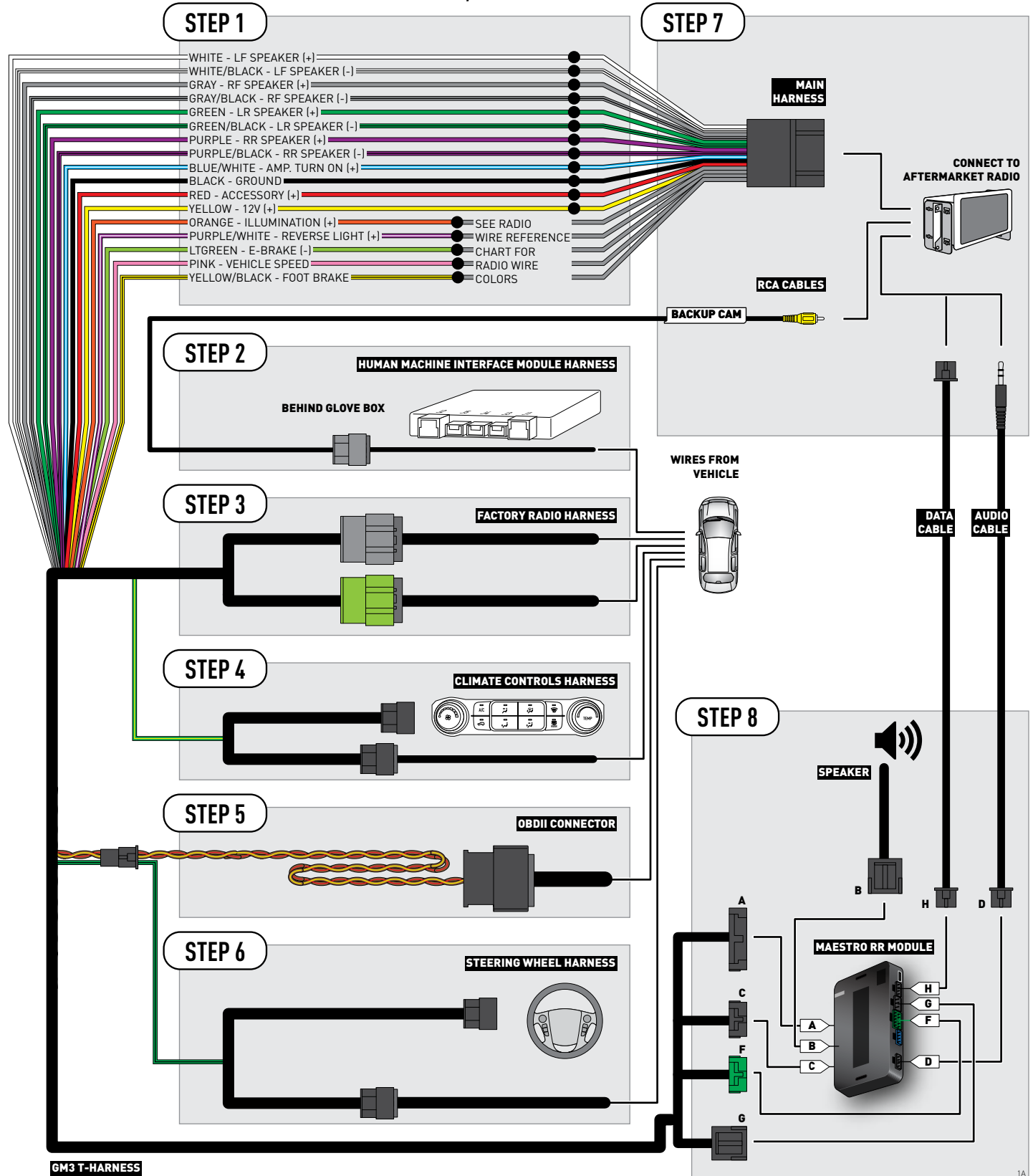

WIRING DIAGRAM *with an Amplifier*

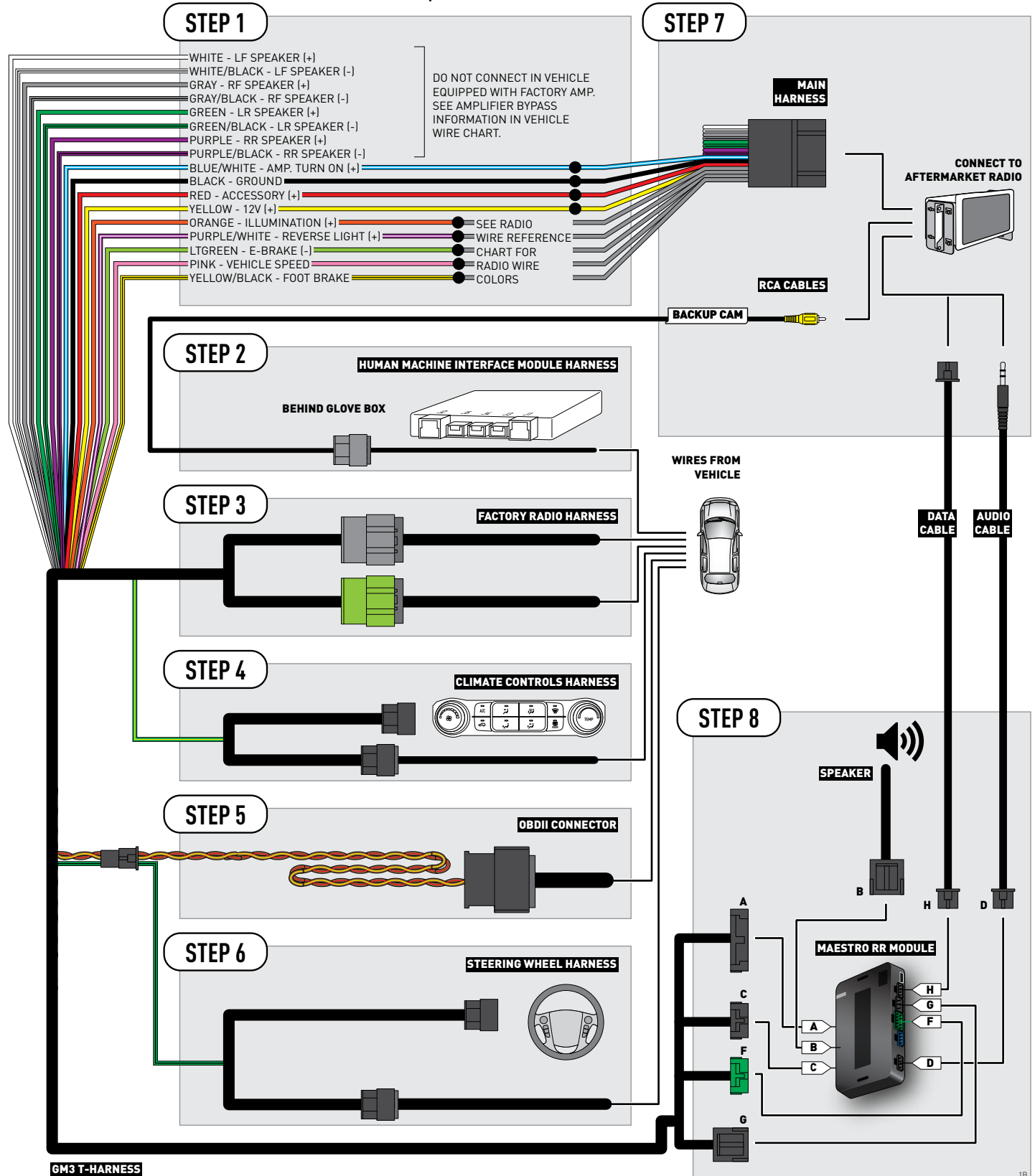

RADIO WIRE REFERENCE CHART

Wire Description	Polarity	Wire Color on Maestro T-Harness	Wire Color on Alpine cable	Wire Color on Kenwood cable	Wire Color on Pioneer cable
Illumination	(+)	Orange	N/A	Orange/White	Orange/White
Reverse Light	(+)	Purple/White	Orange/White	Purple/White	Purple/White
E-Brake	(-)	Lt Green	Yellow/Blue	Lt Green	Lt Green
Foot Brake	(+)	Yellow/Black	Yellow/Black	N/A	N/A
VSS (vehicle speed sensor)	(DATA)	Pink	Green/White	N/A	Pink

VEHICLE WIRE REFERENCE CHART

Wire Description	Connector Name	Connector Color	Connector Type	Position	Wire Color	Polarity	Wire Location
Subwoofer	~	~	8 pin	01	DkBlue/Gray	(+)	Amplifier, back wall of the cab, center of the wall
Subwoofer	~	~	8 pin	05	Gray/Black	(-)	Amplifier, back wall of the cab, center of the wall
RF Speaker	~	~	8 pin	02	Yellow	(+)	Amplifier, back wall of the cab, center of the wall
RF Speaker	~	~	8 pin	06	Yellow/Black	(-)	Amplifier, back wall of the cab, center of the wall
LF Speaker	~	~	8 pin	03	DkBlue	(+)	Amplifier, back wall of the cab, center of the wall
LF Speaker	~	~	8 pin	07	Brown/DkBlue	(-)	Amplifier, back wall of the cab, center of the wall
RF Tweeter (if equipped)	~	~	16 pin	04	Brown/LtGreen	(+)	Amplifier, back wall of the cab, center of the wall
RF Tweeter (if equipped)	~	~	16 pin	12	Purple/Brown	(-)	Amplifier, back wall of the cab, center of the wall
LF Tweeter (if equipped)	~	~	16 pin	05	Yellow/DkBlue	(+)	Amplifier, back wall of the cab, center of the wall
LF Tweeter (if equipped)	~	~	16 pin	13	Yellow/Gray	(-)	Amplifier, back wall of the cab, center of the wall
RR Speaker	~	~	16 pin	06	White	(+)	Amplifier, back wall of the cab, center of the wall
RR Speaker	~	~	16 pin	14	DkBlue/Black	(-)	Amplifier, back wall of the cab, center of the wall
LR Speaker	~	~	16 pin	07	LtGreen	(+)	Amplifier, back wall of the cab, center of the wall
LR Speaker	~	~	16 pin	15	LtGreen/Black	(-)	Amplifier, back wall of the cab, center of the wall

AMPLIFIER CONNECTORS (WIRE SIDE)

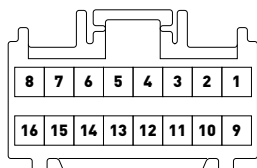
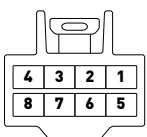



INSTALL GUIDE

CHEVROLET SUBURBAN

2015-2017

RETAINS STEERING WHEEL CONTROLS, ONSTAR, AND MORE!



PRODUCTS REQUIRED

iDatalink Maestro RR Radio Replacement Interface
iDatalink Maestro GM3 Installation Harness

OPTIONAL ACCESSORIES

None

PROGRAMMED FIRMWARE

ADS-RR(SR)-GMS03-DS

NOTICE: Automotive Data Solutions Inc. (ADS) recommends having this installation performed by a certified technician. Logos and trademarks used here in are the properties of their respective owners.

WELCOME

Congratulations on the purchase of your iDatalink Maestro RR Radio replacement solution. You are now a few simple steps away from enjoying your new car radio with enhanced features.

Before starting your installation, please ensure that your iDatalink Maestro module is programmed with the correct firmware for your vehicle and that you carefully review the install guide.

Please note that Maestro RR will only retain functionalities that were originally available in the vehicle.

NEED HELP?

 **1 866 427-2999**

 support@idatalink.com

 maestro.idatalink.com/support
www.12voltdata.com/forum

TABLE OF CONTENTS

Installation Instructions	3
Wiring Diagram without an Amplifier	4
Wiring Diagram with an Amplifier	5
Radio Wire Reference Chart	6
Vehicle Wire Reference Chart	7

INSTALLATION INSTRUCTIONS

BEFORE INSTALLING

- Determine if the vehicle has a Bose amplifier. Look for badges on the radio, door panels, and dash that indicate that the vehicle has Bose.

If the vehicle DOES NOT have a factory amplifier:

complete the installation as shown in the wiring diagram **without an amplifier**.

If the vehicle DOES have a factory amplifier:

complete the installation as shown in the wiring diagram **with an amplifier**. The amplifier cannot be retained; it must be bypassed or replaced with an aftermarket amplifier. See the vehicle reference chart for wire colors; bypass instructions are not included.

- Remove the factory radio.

STEP 1

- Unbox the aftermarket radio and locate its main harness.
- Refer to the wiring diagram and connect the wires from aftermarket radio main harness to the GM3 T-harness and match the wire functions.

STEP 2

- If the vehicle is equipped with an OEM backup camera, connect the backup camera harness to the Human Machine Interface module harness, located behind the glove box. Note: The guide lines of the backup camera will not be retained.

STEP 3

- Connect the factory harness to the GM3 T-harness.

STEP 4

Plug the climate control portion of the GM3 T-harness into the climate controls.

STEP 5

- Plug the male BLACK 3 pin connector of your GM3 T-harness into the OBDII/SW control harness.

- Plug the OBDII connector into the OBDII of the vehicle.

STEP 6

- Remove steering column shroud.
- Plug the steering wheel control T-harness into the harness at the steering wheel (steering wheel connector located at bottom of steering column).

STEP 7

- Plug the aftermarket radio harnesses into the aftermarket radio.
- Connect the backup camera RCA cable harness into the aftermarket radio.
- Plug the Data cable to the data port of the aftermarket radio.
- Insert the Audio cable into the iDatalink 3.5 mm audio jack of the aftermarket radio.

STEP 8

- Connect all the harnesses to the Maestro RR module then proceed test your installation.

TROUBLESHOOTING TIPS:

- To reset the module back its factory settings, turn the key to the OFF position then disconnect all connectors from the module. Press and hold the module's programming button and connect all the connectors back to the module. Wait, the module's LED will flash RED rapidly (this may take up to 10 seconds). Release the programming button. Wait, the LED will turn solid GREEN for 2 seconds.
- For technical assistance call 1-866-427-2999 or e-mail "support@idatalink.com". Visit us at "maestro.idatalink.com/support" and "www.12voltdata.com/forum/"

WIRING DIAGRAM *without an Amplifier*

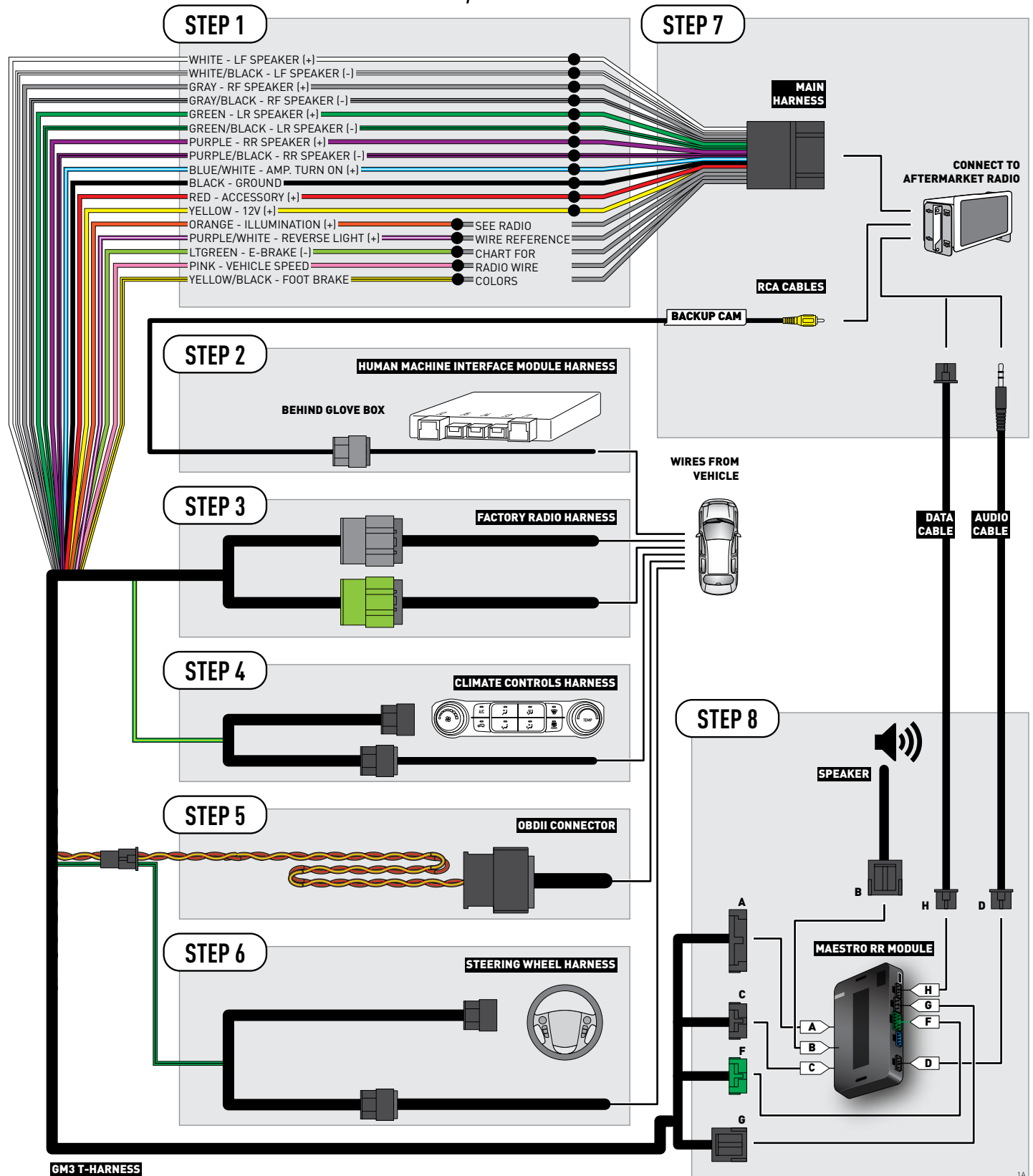

WIRING DIAGRAM *with an Amplifier*

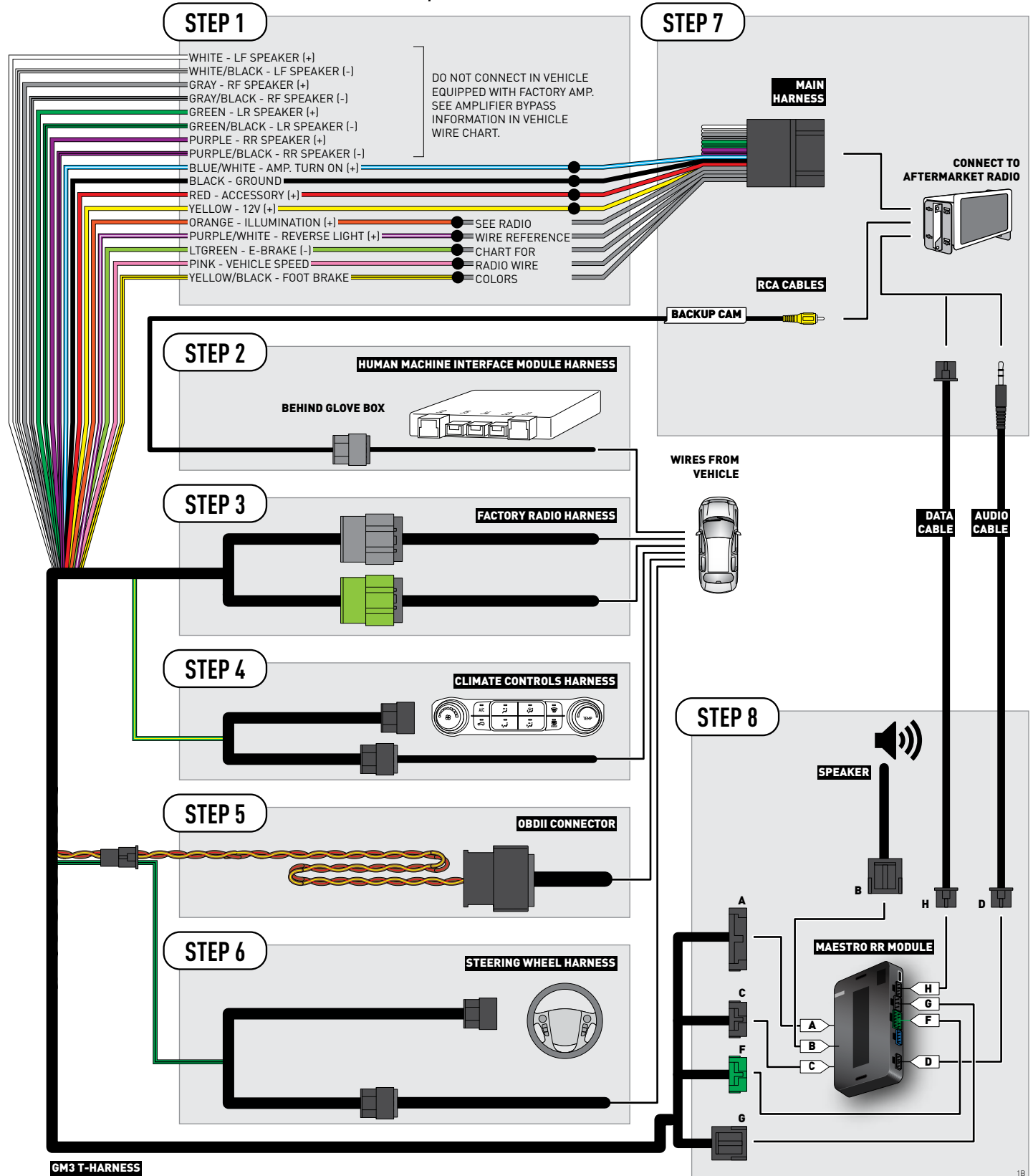

RADIO WIRE REFERENCE CHART

Wire Description	Polarity	Wire Color on Maestro T-Harness	Wire Color on Alpine cable	Wire Color on Kenwood cable	Wire Color on Pioneer cable
Illumination	(+)	Orange	N/A	Orange/White	Orange/White
Reverse Light	(+)	Purple/White	Orange/White	Purple/White	Purple/White
E-Brake	(-)	Lt Green	Yellow/Blue	Lt Green	Lt Green
Foot Brake	(+)	Yellow/Black	Yellow/Black	N/A	N/A
VSS (vehicle speed sensor)	(DATA)	Pink	Green/White	N/A	Pink

VEHICLE WIRE REFERENCE CHART

Wire Description	Connector Name	Connector Color	Connector Type	Position	Wire Color	Polarity	Wire Location
Subwoofer	~	~	8 pin	01	DkBlue/Gray	(+)	Amplifier, left side of cargo area, behind wheel well
Subwoofer	~	~	8 pin	05	Gray/Black	(-)	Amplifier, left side of cargo area, behind wheel well
RF Speaker	~	~	8 pin	02	Yellow	(+)	Amplifier, left side of cargo area, behind wheel well
RF Speaker	~	~	8 pin	06	Yellow/Black	(-)	Amplifier, left side of cargo area, behind wheel well
LF Speaker	~	~	8 pin	03	DkBlue	(+)	Amplifier, left side of cargo area, behind wheel well
LF Speaker	~	~	8 pin	07	Brown/DkBlue	(-)	Amplifier, left side of cargo area, behind wheel well
RF Tweeter (if equipped)	~	~	16 pin	04	Brown/LtGreen	(+)	Amplifier, left side of cargo area, behind wheel well
RF Tweeter (if equipped)	~	~	16 pin	12	Purple/Brown	(-)	Amplifier, left side of cargo area, behind wheel well
LF Tweeter (if equipped)	~	~	16 pin	05	Yellow/DkBlue	(+)	Amplifier, left side of cargo area, behind wheel well
LF Tweeter (if equipped)	~	~	16 pin	13	Yellow/Gray	(-)	Amplifier, left side of cargo area, behind wheel well
RR Speaker	~	~	16 pin	06	White	(+)	Amplifier, left side of cargo area, behind wheel well
RR Speaker	~	~	16 pin	14	DkBlue/Black	(-)	Amplifier, left side of cargo area, behind wheel well
LR Speaker	~	~	16 pin	07	LtGreen	(+)	Amplifier, left side of cargo area, behind wheel well
LR Speaker	~	~	16 pin	15	LtGreen/Black	(-)	Amplifier, left side of cargo area, behind wheel well

AMPLIFIER CONNECTORS (WIRE SIDE)

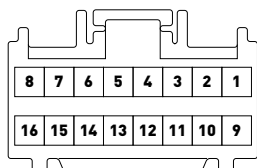
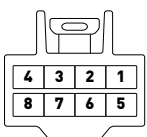



INSTALL GUIDE CHEVROLET TAHOE 2015-2017

RETAINS STEERING WHEEL CONTROLS, ONSTAR, AND MORE!



PRODUCTS REQUIRED

iDatalink Maestro RR Radio Replacement Interface
iDatalink Maestro GM3 Installation Harness

OPTIONAL ACCESSORIES

None

PROGRAMMED FIRMWARE

ADS-RR(SR)-GMS03-DS

NOTICE: Automotive Data Solutions Inc. (ADS) recommends having this installation performed by a certified technician. Logos and trademarks used here in are the properties of their respective owners.

WELCOME

Congratulations on the purchase of your iDatalink Maestro RR Radio replacement solution. You are now a few simple steps away from enjoying your new car radio with enhanced features.

Before starting your installation, please ensure that your iDatalink Maestro module is programmed with the correct firmware for your vehicle and that you carefully review the install guide.

Please note that Maestro RR will only retain functionalities that were originally available in the vehicle.

NEED HELP?

 **1 866 427-2999**

 support@idatalink.com

 maestro.idatalink.com/support
www.12voltdata.com/forum

TABLE OF CONTENTS

Installation Instructions	3
Wiring Diagram without an Amplifier	4
Wiring Diagram with an Amplifier	5
Radio Wire Reference Chart	6
Vehicle Wire Reference Chart	7

INSTALLATION INSTRUCTIONS

BEFORE INSTALLING

- Determine if the vehicle has a Bose amplifier. Look for badges on the radio, door panels, and dash that indicate that the vehicle has Bose.

If the vehicle **DOES NOT** have a factory amplifier:

complete the installation as shown in the wiring diagram **without an amplifier**.

If the vehicle **DOES** have a factory amplifier:

complete the installation as shown in the wiring diagram **with an amplifier**. The amplifier cannot be retained; it must be bypassed or replaced with an aftermarket amplifier. See the vehicle reference chart for wire colors; bypass instructions are not included.

- Remove the factory radio.

STEP 1

- Unbox the aftermarket radio and locate its main harness.
- Refer to the wiring diagram and connect the wires from aftermarket radio main harness to the GM3 T-harness and match the wire functions.

STEP 2

- If the vehicle is equipped with an OEM backup camera, connect the backup camera harness to the Human Machine Interface module harness, located behind the glove box. Note: The guide lines of the backup camera will not be retained.

STEP 3

- Connect the factory harness to the GM3 T-harness.

STEP 4

Plug the climate control portion of the GM3 T-harness into the climate controls.

STEP 5

- Plug the male BLACK 3 pin connector of your GM3 T-harness into the OBDII/SW control harness.

- Plug the OBDII connector into the OBDII of the vehicle.

STEP 6

- Remove steering column shroud.
- Plug the steering wheel control T-harness into the harness at the steering wheel (steering wheel connector located at bottom of steering column).

STEP 7

- Plug the aftermarket radio harnesses into the aftermarket radio.
- Connect the backup camera RCA cable harness into the aftermarket radio.
- Plug the Data cable to the data port of the aftermarket radio.
- Insert the Audio cable into the iDatalink 3.5 mm audio jack of the aftermarket radio.

STEP 8

- Connect all the harnesses to the Maestro RR module then proceed test your installation.

TROUBLESHOOTING TIPS:

- To reset the module back its factory settings, turn the key to the OFF position then disconnect all connectors from the module. Press and hold the module's programming button and connect all the connectors back to the module. Wait, the module's LED will flash RED rapidly (this may take up to 10 seconds). Release the programming button. Wait, the LED will turn solid GREEN for 2 seconds.
- For technical assistance call 1-866-427-2999 or e-mail "support@idatalink.com". Visit us at "maestro.idatalink.com/support" and "www.12voltdata.com/forum/"

WIRING DIAGRAM *without an Amplifier*

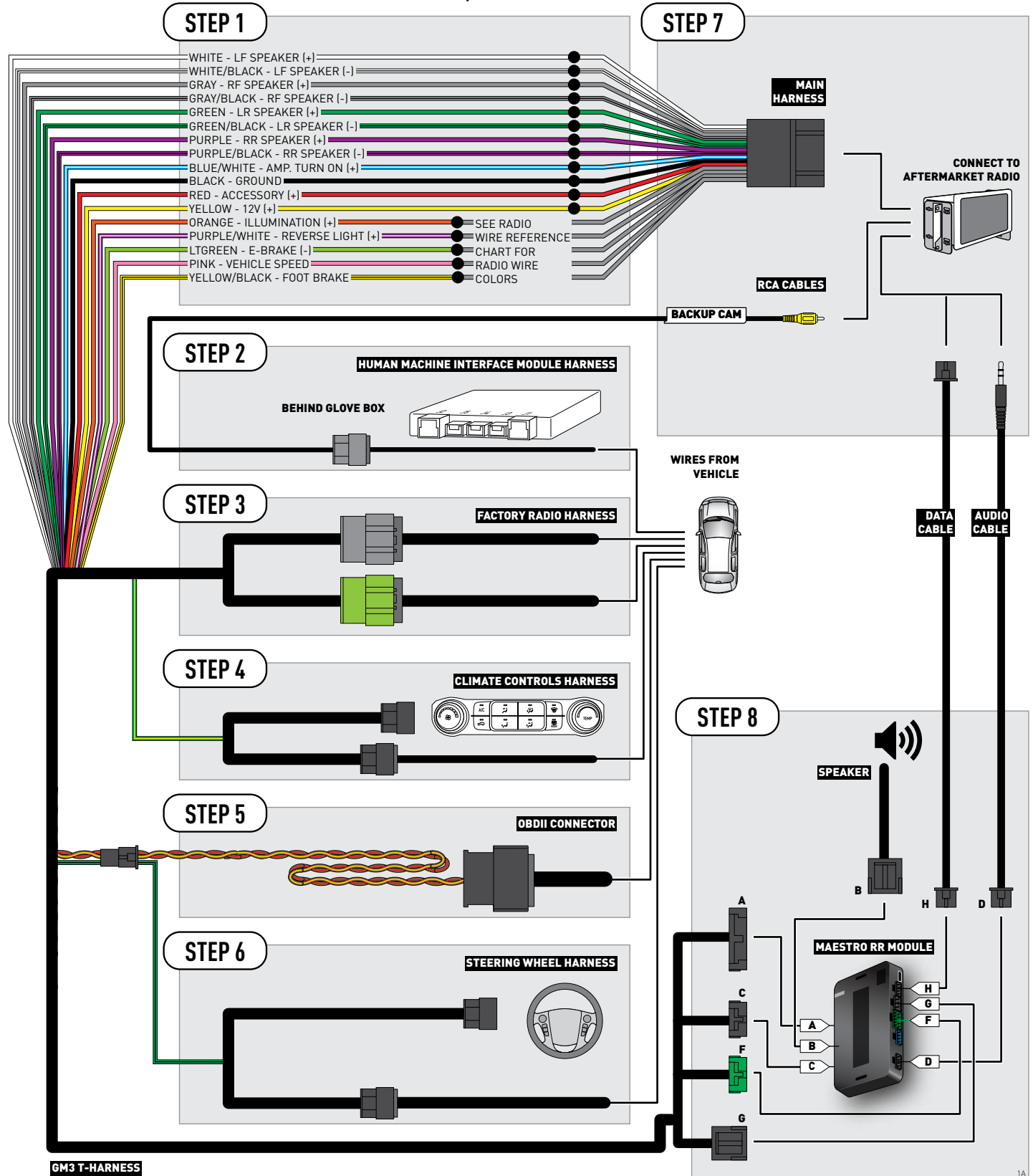

WIRING DIAGRAM *with an Amplifier*

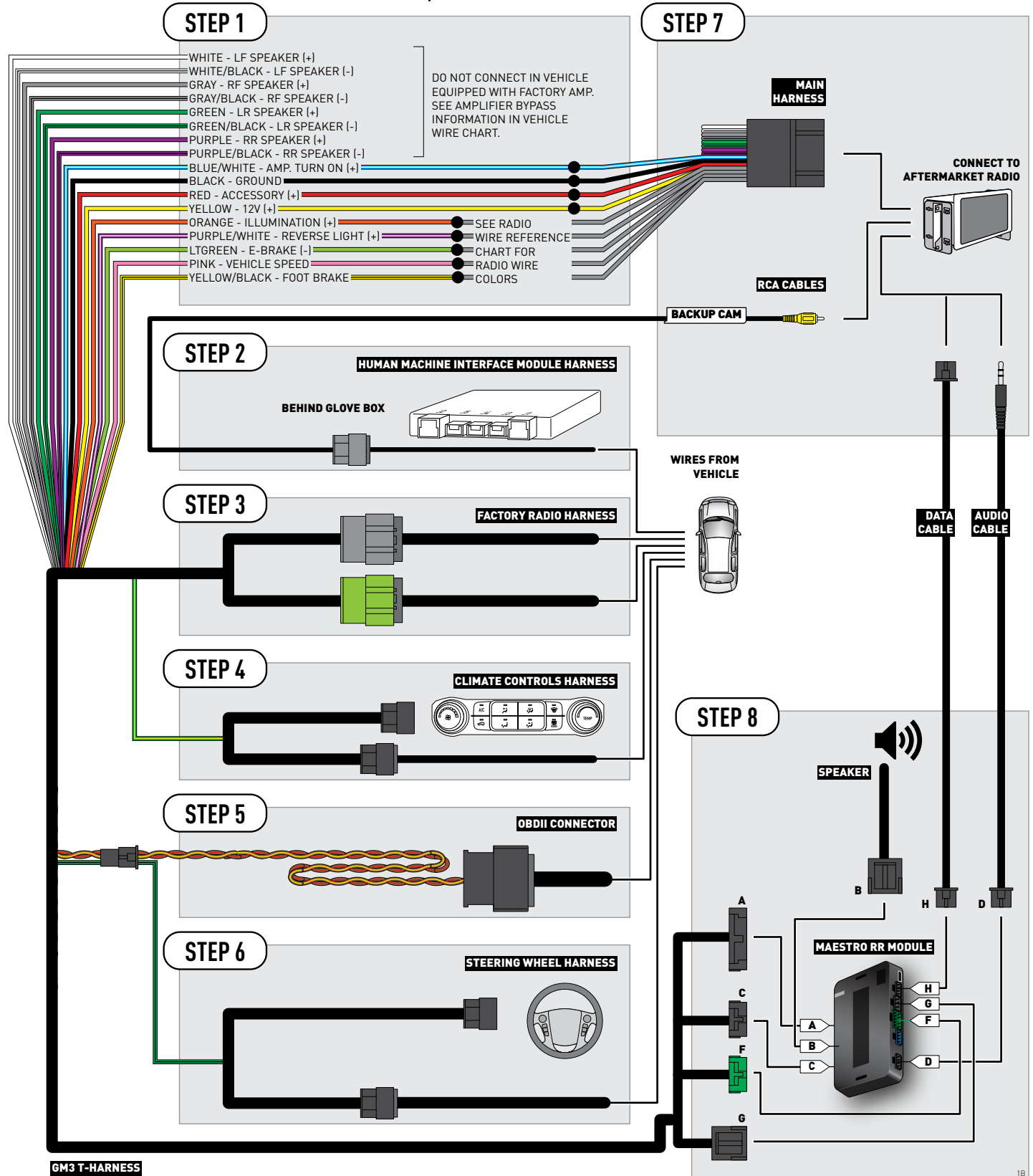

RADIO WIRE REFERENCE CHART

Wire Description	Polarity	Wire Color on Maestro T-Harness	Wire Color on Alpine cable	Wire Color on Kenwood cable	Wire Color on Pioneer cable
Illumination	(+)	Orange	N/A	Orange/White	Orange/White
Reverse Light	(+)	Purple/White	Orange/White	Purple/White	Purple/White
E-Brake	(-)	Lt Green	Yellow/Blue	Lt Green	Lt Green
Foot Brake	(+)	Yellow/Black	Yellow/Black	N/A	N/A
VSS (vehicle speed sensor)	(DATA)	Pink	Green/White	N/A	Pink

VEHICLE WIRE REFERENCE CHART

Wire Description	Connector Name	Connector Color	Connector Type	Position	Wire Color	Polarity	Wire Location
Subwoofer	~	~	8 pin	01	DkBlue/Gray	(+)	Amplifier, left side of cargo area, behind wheel well
Subwoofer	~	~	8 pin	05	Gray/Black	(-)	Amplifier, left side of cargo area, behind wheel well
RF Speaker	~	~	8 pin	02	Yellow	(+)	Amplifier, left side of cargo area, behind wheel well
RF Speaker	~	~	8 pin	06	Yellow/Black	(-)	Amplifier, left side of cargo area, behind wheel well
LF Speaker	~	~	8 pin	03	DkBlue	(+)	Amplifier, left side of cargo area, behind wheel well
LF Speaker	~	~	8 pin	07	Brown/DkBlue	(-)	Amplifier, left side of cargo area, behind wheel well
RF Tweeter (if equipped)	~	~	16 pin	04	Brown/LtGreen	(+)	Amplifier, left side of cargo area, behind wheel well
RF Tweeter (if equipped)	~	~	16 pin	12	Purple/Brown	(-)	Amplifier, left side of cargo area, behind wheel well
LF Tweeter (if equipped)	~	~	16 pin	05	Yellow/DkBlue	(+)	Amplifier, left side of cargo area, behind wheel well
LF Tweeter (if equipped)	~	~	16 pin	13	Yellow/Gray	(-)	Amplifier, left side of cargo area, behind wheel well
RR Speaker	~	~	16 pin	06	White	(+)	Amplifier, left side of cargo area, behind wheel well
RR Speaker	~	~	16 pin	14	DkBlue/Black	(-)	Amplifier, left side of cargo area, behind wheel well
LR Speaker	~	~	16 pin	07	LtGreen	(+)	Amplifier, left side of cargo area, behind wheel well
LR Speaker	~	~	16 pin	15	LtGreen/Black	(-)	Amplifier, left side of cargo area, behind wheel well

AMPLIFIER CONNECTORS (WIRE SIDE)

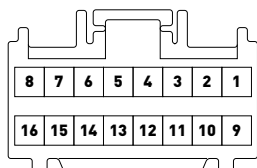
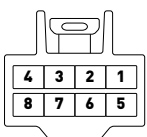



INSTALL GUIDE GMC CANYON 2015-2017

RETAINS STEERING WHEEL CONTROLS, ONSTAR, AND MORE!



PRODUCTS REQUIRED

iDatalink Maestro RR Radio Replacement Interface
iDatalink Maestro GM3 Installation Harness

OPTIONAL ACCESSORIES

None

PROGRAMMED FIRMWARE

ADS-RR(SR)-GMS03-DS

NOTICE: Automotive Data Solutions Inc. (ADS) recommends having this installation performed by a certified technician. Logos and trademarks used here in are the properties of their respective owners.

WELCOME

Congratulations on the purchase of your iDatalink Maestro RR Radio replacement solution. You are now a few simple steps away from enjoying your new car radio with enhanced features.

Before starting your installation, please ensure that your iDatalink Maestro module is programmed with the correct firmware for your vehicle and that you carefully review the install guide.

Please note that Maestro RR will only retain functionalities that were originally available in the vehicle.

NEED HELP?

 **1 866 427-2999**

 support@idatalink.com

 maestro.idatalink.com/support
www.12voltdata.com/forum

TABLE OF CONTENTS

Installation Instructions	3
Wiring Diagram without an Amplifier	4
Wiring Diagram with an Amplifier	5
Radio Wire Reference Chart	6
Vehicle Wire Reference Chart	7

INSTALLATION INSTRUCTIONS

BEFORE INSTALLING

- Determine if the vehicle has a Bose amplifier. Look for badges on the radio, door panels, and dash that indicate that the vehicle has Bose.

If the vehicle DOES NOT have a factory amplifier:

complete the installation as shown in the wiring diagram **without an amplifier**.

If the vehicle DOES have a factory amplifier:

complete the installation as shown in the wiring diagram **with an amplifier**. The amplifier cannot be retained; it must be bypassed or replaced with an aftermarket amplifier. See the vehicle reference chart for wire colors; bypass instructions are not included.

- Remove the factory radio.

STEP 1

- Unbox the aftermarket radio and locate its main harness.
- Refer to the wiring diagram and connect the wires from aftermarket radio main harness to the GM3 T-harness and match the wire functions.

STEP 2

- If the vehicle is equipped with an OEM backup camera, connect the backup camera harness to the Human Machine Interface module harness, located at the bottom of the radio cavity. Note: The guide lines of the backup camera will not be retained.

STEP 3

- Connect the factory harness to the GM3 T-harness.

STEP 4

Plug the climate control portion of the GM3 T-harness into the climate controls.

STEP 5

- Plug the male BLACK 3 pin connector of your GM3 T-harness into the OBDII/SW control harness.

- Plug the OBDII connector into the OBDII of the vehicle.

STEP 6

If the vehicle DOES have steering wheel controls:

- Remove steering column shroud.
- Locate the steering wheel control wire in the GM3 steering wheel harness. Cut the GREEN/BLACK wire and splice it into pin 9.
- Plug the steering wheel control T-harness into the harness at the steering wheel (steering wheel connector located at top of steering column).

STEP 7

- Plug the aftermarket radio harnesses into the aftermarket radio.
- Connect the backup camera RCA cable harness into the aftermarket radio.
- Plug the Data cable to the data port of the aftermarket radio.
- Insert the Audio cable into the iDatalink 3.5 mm audio jack of the aftermarket radio.

STEP 8

- Connect all the harnesses to the Maestro RR module then proceed test your installation.

TROUBLESHOOTING TIPS:

- To reset the module back its factory settings, turn the key to the OFF position then disconnect all connectors from the module. Press and hold the module's programming button and connect all the connectors back to the module. Wait, the module's LED will flash RED rapidly (this may take up to 10 seconds). Release the programming button. Wait, the LED will turn solid GREEN for 2 seconds.
- For technical assistance call 1-866-427-2999 or e-mail "support@idatalink.com". Visit us at "maestro.idatalink.com/support" and "www.12voltdata.com/forum/"

WIRING DIAGRAM *without an Amplifier*

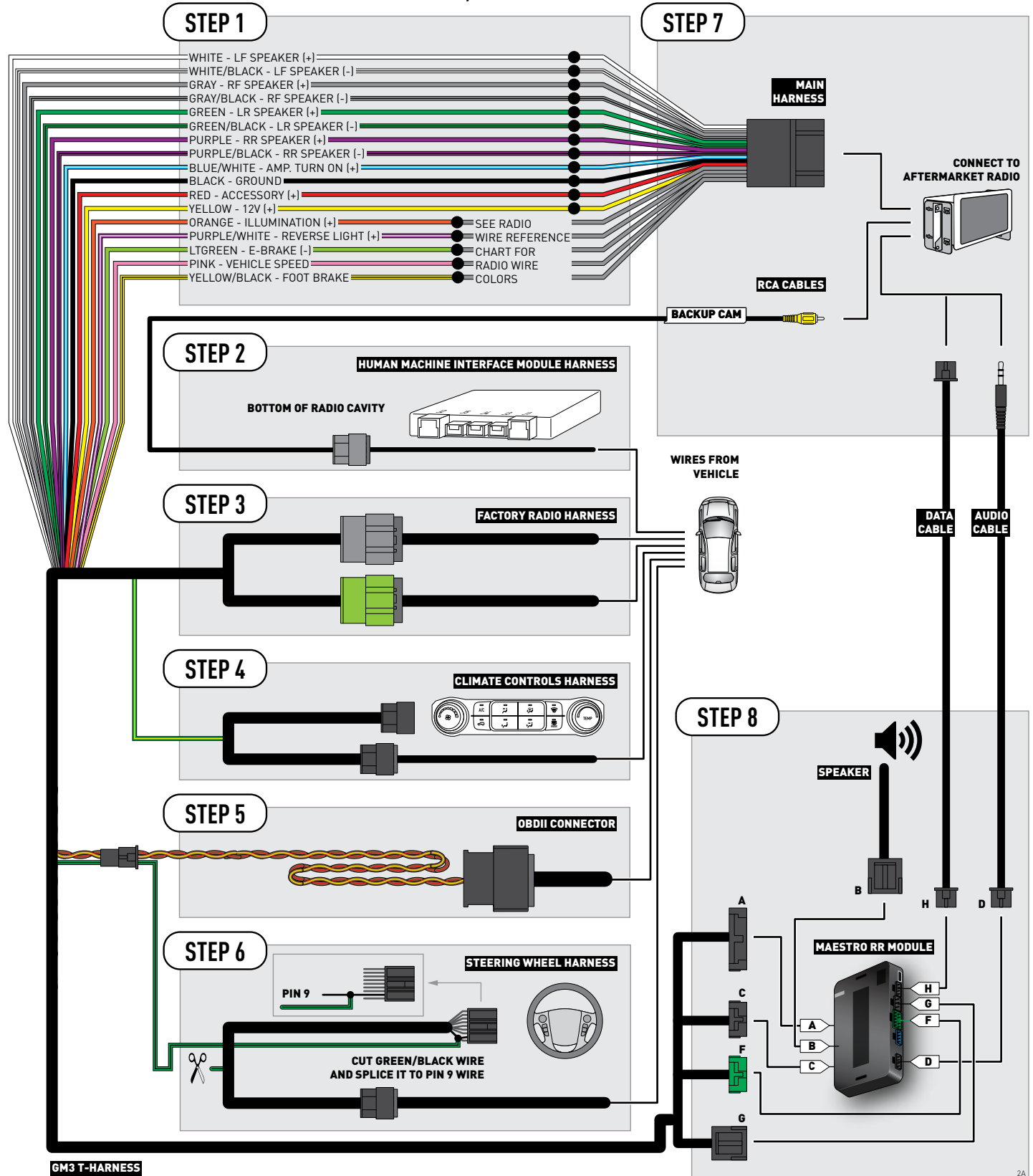

WIRING DIAGRAM *with an Amplifier*

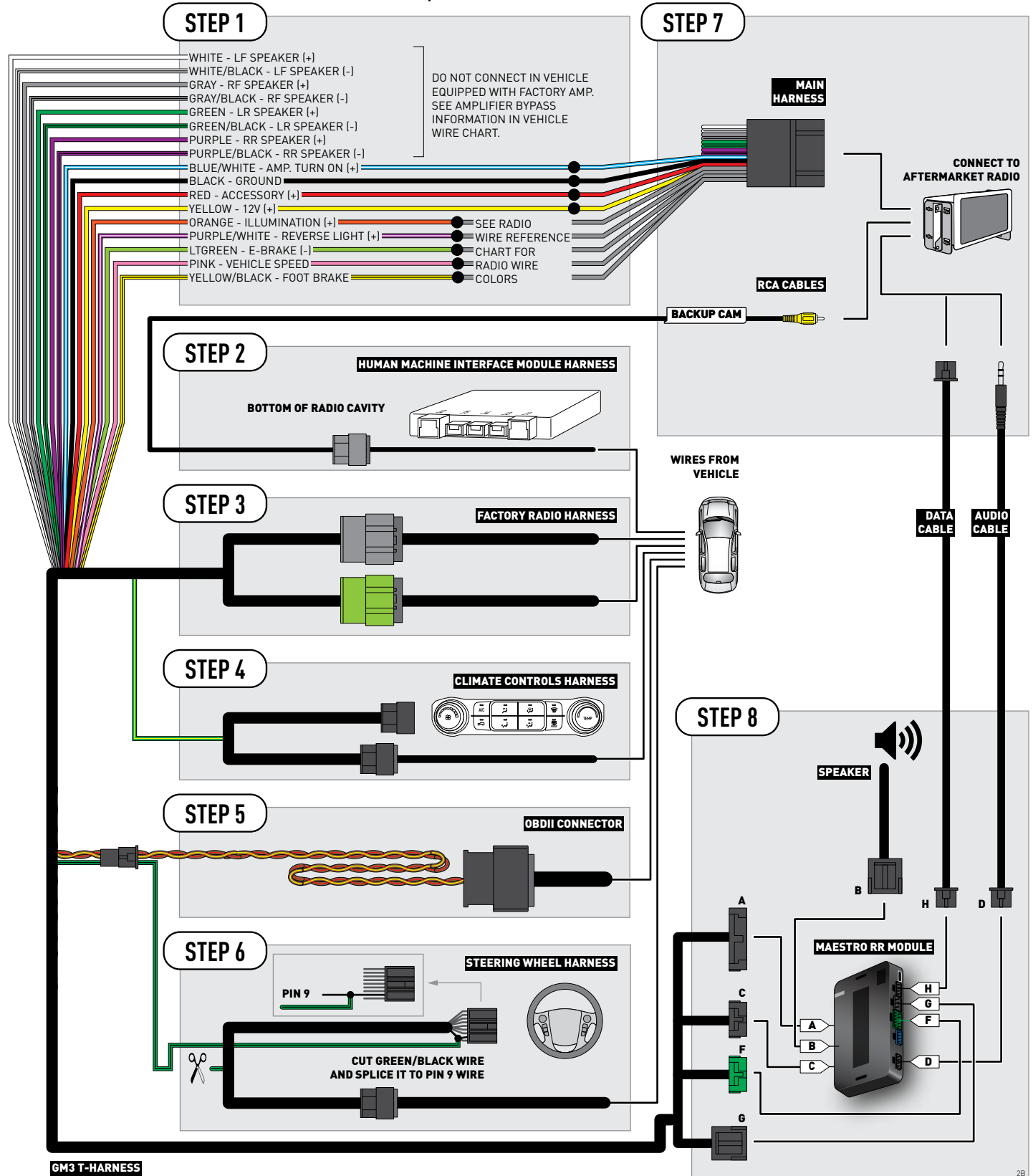

RADIO WIRE REFERENCE CHART

Wire Description	Polarity	Wire Color on Maestro T-Harness	Wire Color on Alpine cable	Wire Color on Kenwood cable	Wire Color on Pioneer cable
Illumination	(+)	Orange	N/A	Orange/White	Orange/White
Reverse Light	(+)	Purple/White	Orange/White	Purple/White	Purple/White
E-Brake	(-)	Lt Green	Yellow/Blue	Lt Green	Lt Green
Foot Brake	(+)	Yellow/Black	Yellow/Black	N/A	N/A
VSS (vehicle speed sensor)	(DATA)	Pink	Green/White	N/A	Pink

VEHICLE WIRE REFERENCE CHART

Wire Description	Connector Name	Connector Color	Connector Type	Position	Wire Color	Polarity	Wire Location
Subwoofer	~	~	8 pin	01	DkBlue/Gray	(+)	Amplifier, in dashboard, to the right of the glove box
Subwoofer	~	~	8 pin	05	Gray/Black	(-)	Amplifier, in dashboard, to the right of the glove box
RF Speaker	~	~	8 pin	02	Yellow	(+)	Amplifier, in dashboard, to the right of the glove box
RF Speaker	~	~	8 pin	06	Yellow/Black	(-)	Amplifier, in dashboard, to the right of the glove box
LF Speaker	~	~	8 pin	03	DkBlue	(+)	Amplifier, in dashboard, to the right of the glove box
LF Speaker	~	~	8 pin	07	Brown/DkBlue	(-)	Amplifier, in dashboard, to the right of the glove box
RF Tweeter (if equipped)	~	~	16 pin	04	Brown/LtGreen	(+)	Amplifier, in dashboard, to the right of the glove box
RF Tweeter (if equipped)	~	~	16 pin	12	Purple/Brown	(-)	Amplifier, in dashboard, to the right of the glove box
LF Tweeter (if equipped)	~	~	16 pin	05	Yellow/DkBlue	(+)	Amplifier, in dashboard, to the right of the glove box
LF Tweeter (if equipped)	~	~	16 pin	13	Yellow/Gray	(-)	Amplifier, in dashboard, to the right of the glove box
RR Speaker	~	~	16 pin	06	White	(+)	Amplifier, in dashboard, to the right of the glove box
RR Speaker	~	~	16 pin	14	DkBlue/Black	(-)	Amplifier, in dashboard, to the right of the glove box
LR Speaker	~	~	16 pin	07	LtGreen	(+)	Amplifier, in dashboard, to the right of the glove box
LR Speaker	~	~	16 pin	15	LtGreen/Black	(-)	Amplifier, in dashboard, to the right of the glove box

AMPLIFIER CONNECTORS (WIRE SIDE)

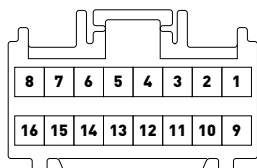
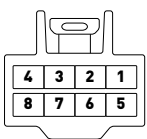



INSTALL GUIDE GMC SIERRA 1500 WITH 4.2" AND 8" RADIOS 2014-2017

RETAINS STEERING WHEEL CONTROLS, ONSTAR, AND MORE!



PRODUCTS REQUIRED

iDatalink Maestro RR Radio Replacement Interface
iDatalink Maestro GM3 Installation Harness

OPTIONAL ACCESSORIES

None

PROGRAMMED FIRMWARE

ADS-RR(SR)-GMS03-DS

NOTICE: Automotive Data Solutions Inc. (ADS) recommends having this installation performed by a certified technician. Logos and trademarks used here in are the properties of their respective owners.

WELCOME

Congratulations on the purchase of your iDatalink Maestro RR Radio replacement solution. You are now a few simple steps away from enjoying your new car radio with enhanced features.

Before starting your installation, please ensure that your iDatalink Maestro module is programmed with the correct firmware for your vehicle and that you carefully review the install guide.

Please note that Maestro RR will only retain functionalities that were originally available in the vehicle.

NEED HELP?

 **1 866 427-2999**

 support@idatalink.com

 maestro.idatalink.com/support
www.12voltdata.com/forum

TABLE OF CONTENTS

Installation Instructions	3
Wiring Diagram without an Amplifier	4
Wiring Diagram with an Amplifier	5
Radio Wire Reference Chart	6
Vehicle Wire Reference Chart	7

INSTALLATION INSTRUCTIONS

BEFORE INSTALLING

- Determine if the vehicle has a Bose amplifier. Look for badges on the radio, door panels, and dash that indicate that the vehicle has Bose.

If the vehicle DOES NOT have a factory amplifier:

complete the installation as shown in the wiring diagram **without an amplifier.**

If the vehicle DOES have a factory amplifier:

complete the installation as shown in the wiring diagram **with an amplifier.** The amplifier cannot be retained; it must be bypassed or replaced with an aftermarket amplifier. See the vehicle reference chart for wire colors; bypass instructions are not included.

- Remove the factory radio.

STEP 1

- Unbox the aftermarket radio and locate its main harness.
- Refer to the wiring diagram and connect the wires from aftermarket radio main harness to the GM3 T-harness and match the wire functions.

STEP 2

- If the vehicle is equipped with an OEM backup camera, connect the backup camera harness to the Human Machine Interface module harness, located behind the glove box. Note: The guide lines of the backup camera will not be retained.

STEP 3

- Connect the factory harness to the GM3 T-harness.

STEP 4

Plug the climate control portion of the GM3 T-harness into the climate controls.

STEP 5

- Plug the male BLACK 3 pin connector of your GM3 T-harness into the OBDII/SW control harness.

- Plug the OBDII connector into the OBDII of the vehicle.

STEP 6

- Remove steering column shroud.
- Plug the steering wheel control T-harness into the harness at the steering wheel (steering wheel connector located at bottom of steering column).

STEP 7

- Plug the aftermarket radio harnesses into the aftermarket radio.
- Connect the backup camera RCA cable harness into the aftermarket radio.
- Plug the Data cable to the data port of the aftermarket radio.
- Insert the Audio cable into the iDatalink 3.5 mm audio jack of the aftermarket radio.

STEP 8

- Connect all the harnesses to the Maestro RR module then proceed test your installation.

TROUBLESHOOTING TIPS:

- To reset the module back its factory settings, turn the key to the OFF position then disconnect all connectors from the module. Press and hold the module's programming button and connect all the connectors back to the module. Wait, the module's LED will flash RED rapidly (this may take up to 10 seconds). Release the programming button. Wait, the LED will turn solid GREEN for 2 seconds.
- For technical assistance call 1-866-427-2999 or e-mail "support@idatalink.com". Visit us at "maestro.idatalink.com/support" and "www.12voltdata.com/forum/"

WIRING DIAGRAM *without an Amplifier*

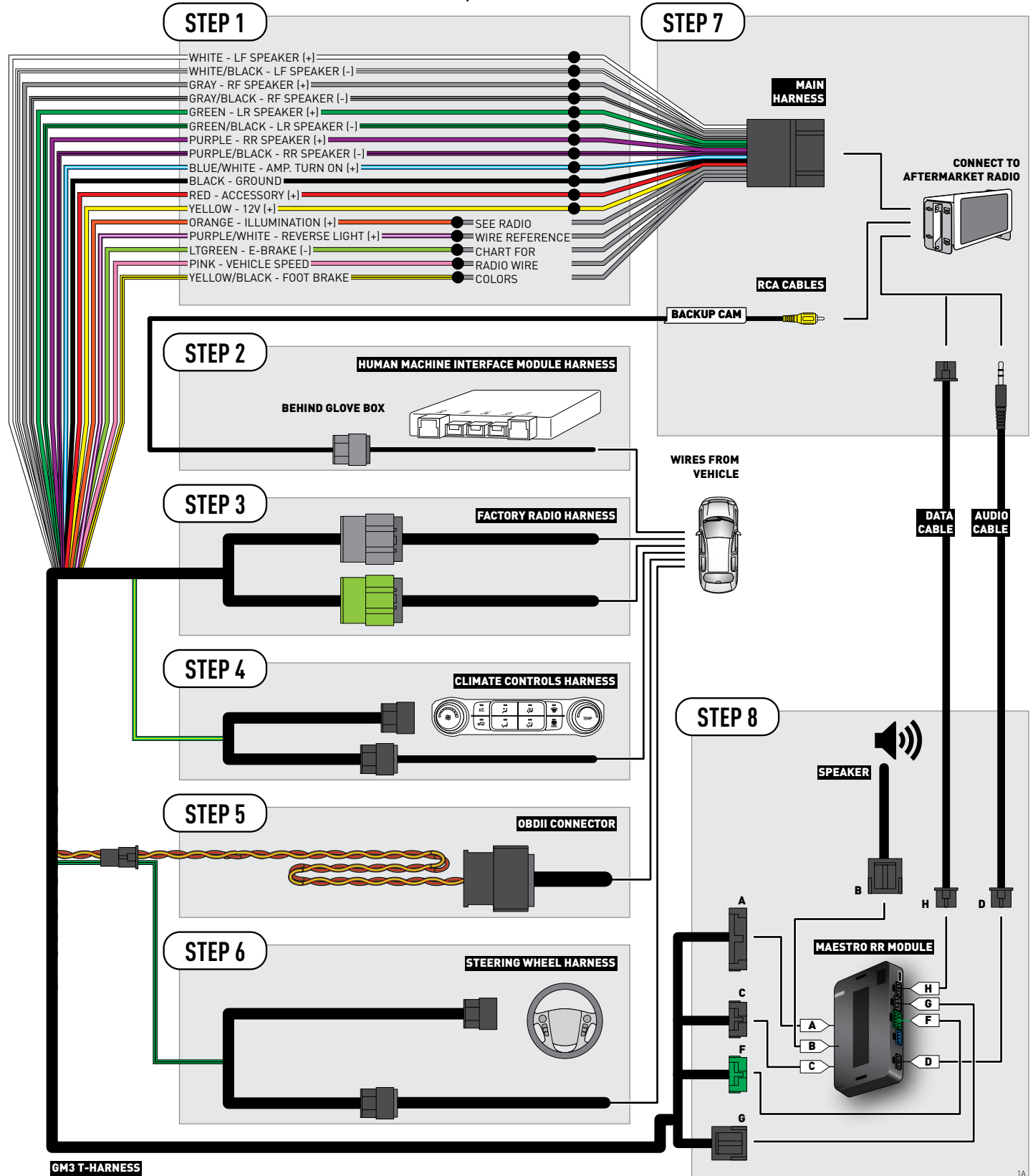

WIRING DIAGRAM *with an Amplifier*

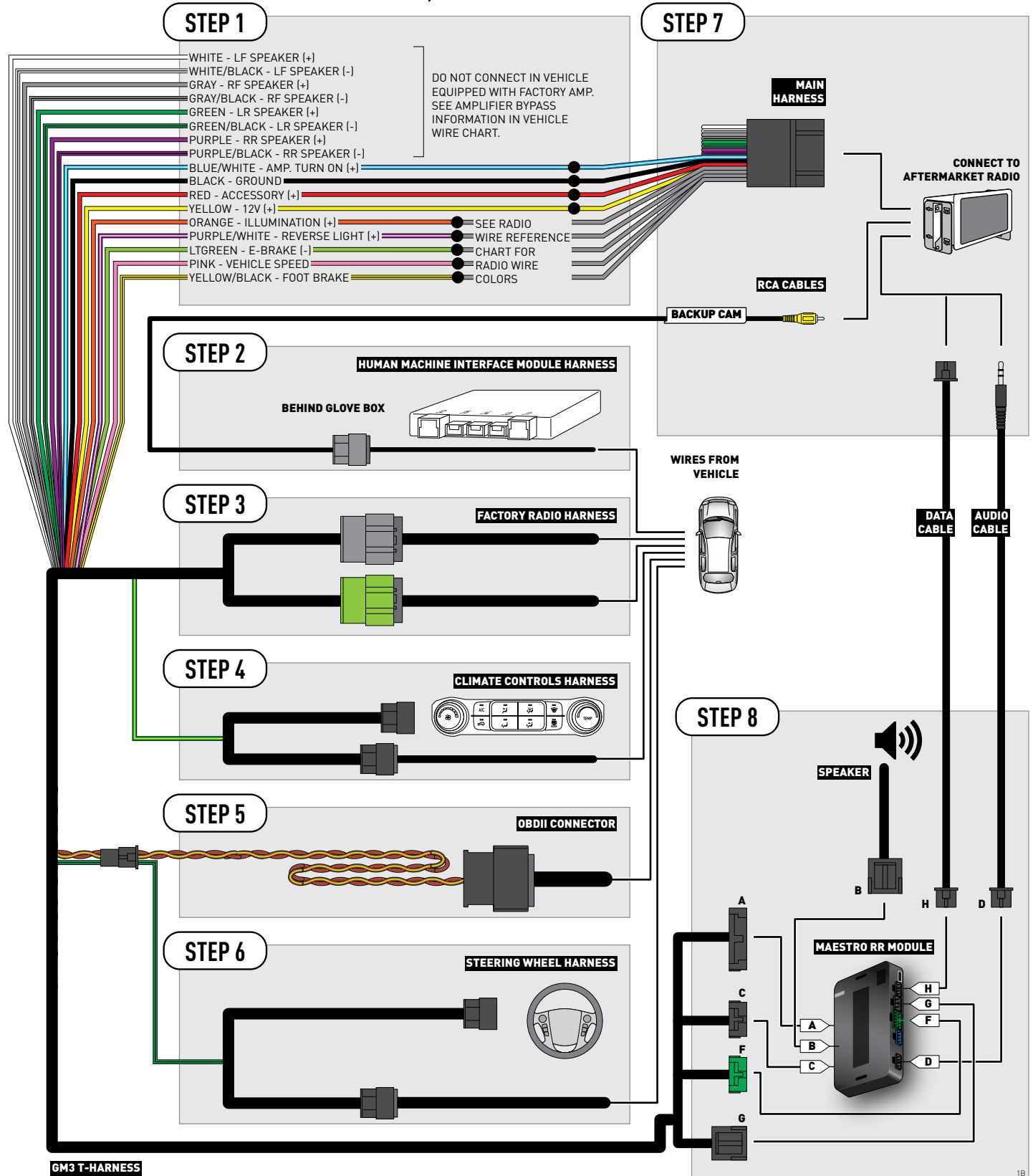

RADIO WIRE REFERENCE CHART

Wire Description	Polarity	Wire Color on Maestro T-Harness	Wire Color on Alpine cable	Wire Color on Kenwood cable	Wire Color on Pioneer cable
Illumination	(+)	Orange	N/A	Orange/White	Orange/White
Reverse Light	(+)	Purple/White	Orange/White	Purple/White	Purple/White
E-Brake	(-)	Lt Green	Yellow/Blue	Lt Green	Lt Green
Foot Brake	(+)	Yellow/Black	Yellow/Black	N/A	N/A
VSS (vehicle speed sensor)	(DATA)	Pink	Green/White	N/A	Pink

VEHICLE WIRE REFERENCE CHART

Wire Description	Connector Name	Connector Color	Connector Type	Position	Wire Color	Polarity	Wire Location
Subwoofer	~	~	8 pin	01	DkBlue/Gray	(+)	Amplifier, back wall of the cab, center of the wall
Subwoofer	~	~	8 pin	05	Gray/Black	(-)	Amplifier, back wall of the cab, center of the wall
RF Speaker	~	~	8 pin	02	Yellow	(+)	Amplifier, back wall of the cab, center of the wall
RF Speaker	~	~	8 pin	06	Yellow/Black	(-)	Amplifier, back wall of the cab, center of the wall
LF Speaker	~	~	8 pin	03	DkBlue	(+)	Amplifier, back wall of the cab, center of the wall
LF Speaker	~	~	8 pin	07	Brown/DkBlue	(-)	Amplifier, back wall of the cab, center of the wall
RF Tweeter (if equipped)	~	~	16 pin	04	Brown/LtGreen	(+)	Amplifier, back wall of the cab, center of the wall
RF Tweeter (if equipped)	~	~	16 pin	12	Purple/Brown	(-)	Amplifier, back wall of the cab, center of the wall
LF Tweeter (if equipped)	~	~	16 pin	05	Yellow/DkBlue	(+)	Amplifier, back wall of the cab, center of the wall
LF Tweeter (if equipped)	~	~	16 pin	13	Yellow/Gray	(-)	Amplifier, back wall of the cab, center of the wall
RR Speaker	~	~	16 pin	06	White	(+)	Amplifier, back wall of the cab, center of the wall
RR Speaker	~	~	16 pin	14	DkBlue/Black	(-)	Amplifier, back wall of the cab, center of the wall
LR Speaker	~	~	16 pin	07	LtGreen	(+)	Amplifier, back wall of the cab, center of the wall
LR Speaker	~	~	16 pin	15	LtGreen/Black	(-)	Amplifier, back wall of the cab, center of the wall

AMPLIFIER CONNECTORS (WIRE SIDE)

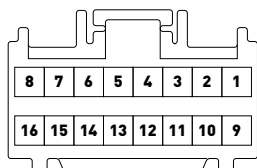
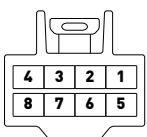



INSTALL GUIDE

GMC SIERRA 2500 & 3500

WITH 4.2" AND 8" RADIOS

2015-2017

RETAINS STEERING WHEEL CONTROLS, ONSTAR, AND MORE!



PRODUCTS REQUIRED

iDatalink Maestro RR Radio Replacement Interface
iDatalink Maestro GM3 Installation Harness

OPTIONAL ACCESSORIES

None

PROGRAMMED FIRMWARE

ADS-RR(SR)-GMS03-DS

NOTICE: Automotive Data Solutions Inc. (ADS) recommends having this installation performed by a certified technician. Logos and trademarks used here in are the properties of their respective owners.

WELCOME

Congratulations on the purchase of your iDatalink Maestro RR Radio replacement solution. You are now a few simple steps away from enjoying your new car radio with enhanced features.

Before starting your installation, please ensure that your iDatalink Maestro module is programmed with the correct firmware for your vehicle and that you carefully review the install guide.

Please note that Maestro RR will only retain functionalities that were originally available in the vehicle.

NEED HELP?

 **1 866 427-2999**

 support@idatalink.com

 maestro.idatalink.com/support
www.12voltdata.com/forum

TABLE OF CONTENTS

Installation Instructions	3
Wiring Diagram without an Amplifier	4
Wiring Diagram with an Amplifier	5
Radio Wire Reference Chart	6
Vehicle Wire Reference Chart	7

INSTALLATION INSTRUCTIONS

BEFORE INSTALLING

- Determine if the vehicle has a Bose amplifier. Look for badges on the radio, door panels, and dash that indicate that the vehicle has Bose.

If the vehicle DOES NOT have a factory amplifier:

complete the installation as shown in the wiring diagram **without an amplifier**.

If the vehicle DOES have a factory amplifier:

complete the installation as shown in the wiring diagram **with an amplifier**. The amplifier cannot be retained; it must be bypassed or replaced with an aftermarket amplifier. See the vehicle reference chart for wire colors; bypass instructions are not included.

- Remove the factory radio.

STEP 1

- Unbox the aftermarket radio and locate its main harness.
- Refer to the wiring diagram and connect the wires from aftermarket radio main harness to the GM3 T-harness and match the wire functions.

STEP 2

- If the vehicle is equipped with an OEM backup camera, connect the backup camera harness to the Human Machine Interface module harness, located behind the glove box. Note: The guide lines of the backup camera will not be retained.

STEP 3

- Connect the factory harness to the GM3 T-harness.

STEP 4

Plug the climate control portion of the GM3 T-harness into the climate controls.

STEP 5

- Plug the male BLACK 3 pin connector of your GM3 T-harness into the OBDII/SW control harness.

- Plug the OBDII connector into the OBDII of the vehicle.

STEP 6

- Remove steering column shroud.
- Plug the steering wheel control T-harness into the harness at the steering wheel (steering wheel connector located at bottom of steering column).

STEP 7

- Plug the aftermarket radio harnesses into the aftermarket radio.
- Connect the backup camera RCA cable harness into the aftermarket radio.
- Plug the Data cable to the data port of the aftermarket radio.
- Insert the Audio cable into the iDatalink 3.5 mm audio jack of the aftermarket radio.

STEP 8

- Connect all the harnesses to the Maestro RR module then proceed test your installation.

TROUBLESHOOTING TIPS:

- To reset the module back its factory settings, turn the key to the OFF position then disconnect all connectors from the module. Press and hold the module's programming button and connect all the connectors back to the module. Wait, the module's LED will flash RED rapidly (this may take up to 10 seconds). Release the programming button. Wait, the LED will turn solid GREEN for 2 seconds.
- For technical assistance call 1-866-427-2999 or e-mail "support@idatalink.com". Visit us at "maestro.idatalink.com/support" and "www.12voltdata.com/forum/"

WIRING DIAGRAM *without an Amplifier*

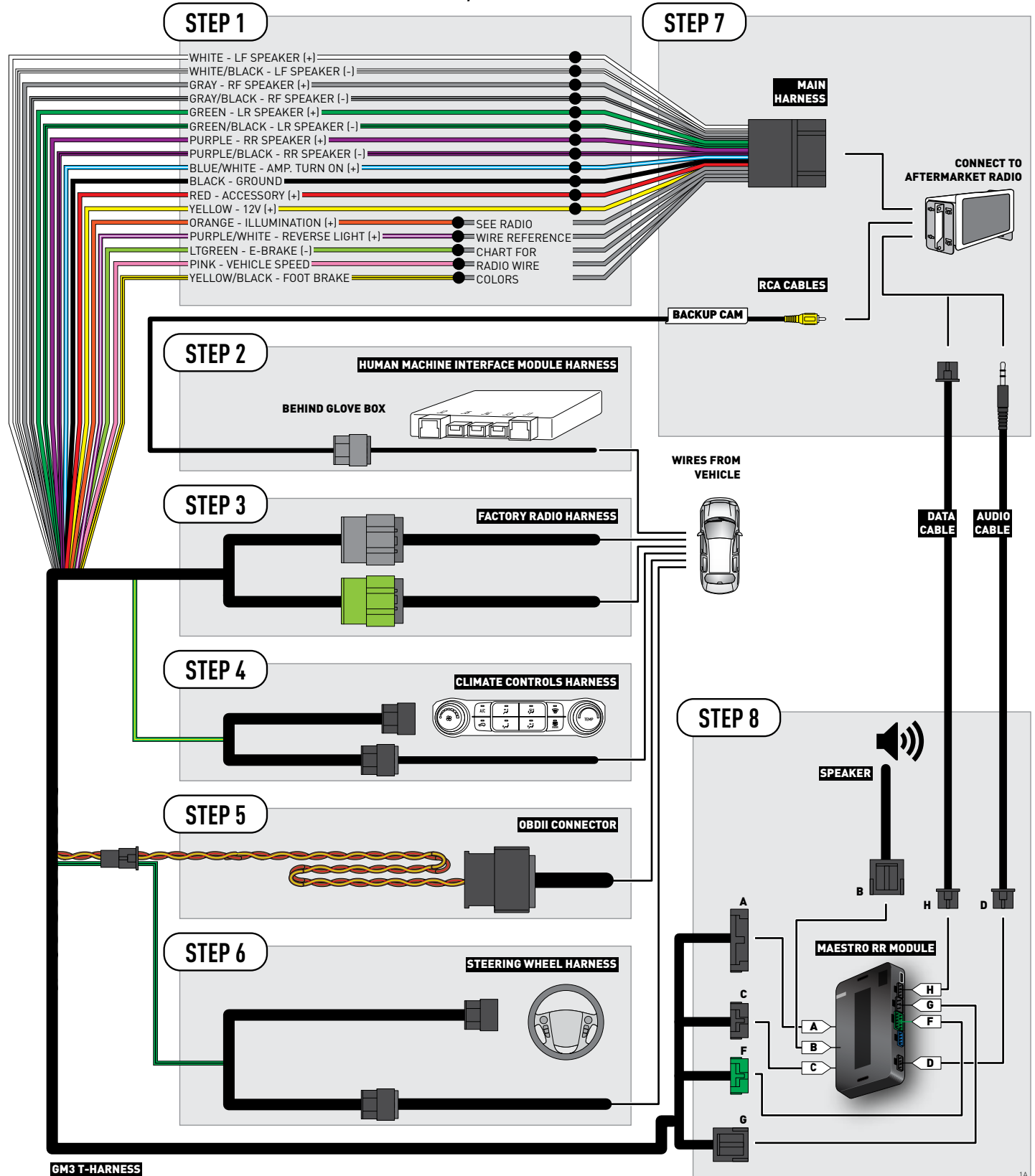

WIRING DIAGRAM *with an Amplifier*

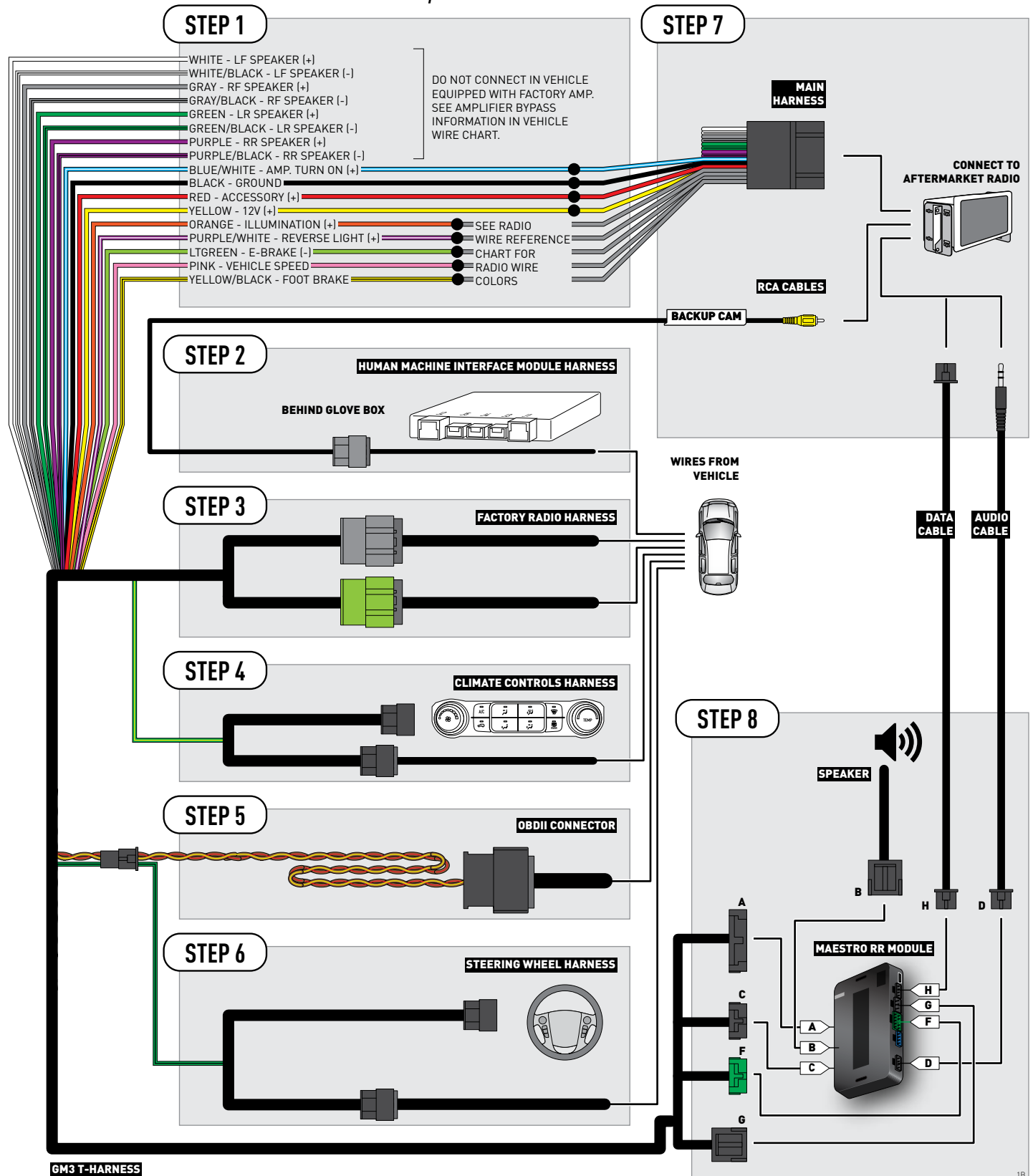

RADIO WIRE REFERENCE CHART

Wire Description	Polarity	Wire Color on Maestro T-Harness	Wire Color on Alpine cable	Wire Color on Kenwood cable	Wire Color on Pioneer cable
Illumination	(+)	Orange	N/A	Orange/White	Orange/White
Reverse Light	(+)	Purple/White	Orange/White	Purple/White	Purple/White
E-Brake	(-)	Lt Green	Yellow/Blue	Lt Green	Lt Green
Foot Brake	(+)	Yellow/Black	Yellow/Black	N/A	N/A
VSS (vehicle speed sensor)	(DATA)	Pink	Green/White	N/A	Pink

VEHICLE WIRE REFERENCE CHART

Wire Description	Connector Name	Connector Color	Connector Type	Position	Wire Color	Polarity	Wire Location
Subwoofer	~	~	8 pin	01	DkBlue/Gray	(+)	Amplifier, back wall of the cab, center of the wall
Subwoofer	~	~	8 pin	05	Gray/Black	(-)	Amplifier, back wall of the cab, center of the wall
RF Speaker	~	~	8 pin	02	Yellow	(+)	Amplifier, back wall of the cab, center of the wall
RF Speaker	~	~	8 pin	06	Yellow/Black	(-)	Amplifier, back wall of the cab, center of the wall
LF Speaker	~	~	8 pin	03	DkBlue	(+)	Amplifier, back wall of the cab, center of the wall
LF Speaker	~	~	8 pin	07	Brown/DkBlue	(-)	Amplifier, back wall of the cab, center of the wall
RF Tweeter (if equipped)	~	~	16 pin	04	Brown/LtGreen	(+)	Amplifier, back wall of the cab, center of the wall
RF Tweeter (if equipped)	~	~	16 pin	12	Purple/Brown	(-)	Amplifier, back wall of the cab, center of the wall
LF Tweeter (if equipped)	~	~	16 pin	05	Yellow/DkBlue	(+)	Amplifier, back wall of the cab, center of the wall
LF Tweeter (if equipped)	~	~	16 pin	13	Yellow/Gray	(-)	Amplifier, back wall of the cab, center of the wall
RR Speaker	~	~	16 pin	06	White	(+)	Amplifier, back wall of the cab, center of the wall
RR Speaker	~	~	16 pin	14	DkBlue/Black	(-)	Amplifier, back wall of the cab, center of the wall
LR Speaker	~	~	16 pin	07	LtGreen	(+)	Amplifier, back wall of the cab, center of the wall
LR Speaker	~	~	16 pin	15	LtGreen/Black	(-)	Amplifier, back wall of the cab, center of the wall

AMPLIFIER CONNECTORS (WIRE SIDE)

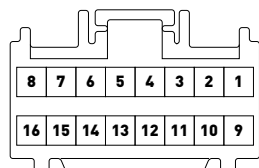
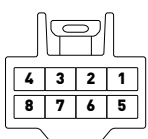



INSTALL GUIDE

GMC YUKON & YUKON XL

2015-2017

RETAINS STEERING WHEEL CONTROLS, ONSTAR, AND MORE!



PRODUCTS REQUIRED

iDatalink Maestro RR Radio Replacement Interface
iDatalink Maestro GM3 Installation Harness

OPTIONAL ACCESSORIES

None

PROGRAMMED FIRMWARE

ADS-RR(SR)-GMS03-DS

NOTICE: Automotive Data Solutions Inc. (ADS) recommends having this installation performed by a certified technician. Logos and trademarks used here in are the properties of their respective owners.

WELCOME

Congratulations on the purchase of your iDatalink Maestro RR Radio replacement solution. You are now a few simple steps away from enjoying your new car radio with enhanced features.

Before starting your installation, please ensure that your iDatalink Maestro module is programmed with the correct firmware for your vehicle and that you carefully review the install guide.

Please note that Maestro RR will only retain functionalities that were originally available in the vehicle.

NEED HELP?

 **1 866 427-2999**

 support@idatalink.com

 maestro.idatalink.com/support
www.12voltdata.com/forum

TABLE OF CONTENTS

Installation Instructions	3
Wiring Diagram without an Amplifier	4
Wiring Diagram with an Amplifier	5
Radio Wire Reference Chart	6
Vehicle Wire Reference Chart	7

INSTALLATION INSTRUCTIONS

BEFORE INSTALLING

- Determine if the vehicle has a Bose amplifier. Look for badges on the radio, door panels, and dash that indicate that the vehicle has Bose.

If the vehicle DOES NOT have a factory amplifier:

complete the installation as shown in the wiring diagram **without an amplifier.**

If the vehicle DOES have a factory amplifier:

complete the installation as shown in the wiring diagram **with an amplifier.** The amplifier cannot be retained; it must be bypassed or replaced with an aftermarket amplifier. See the vehicle reference chart for wire colors; bypass instructions are not included.

- Remove the factory radio.

STEP 1

- Unbox the aftermarket radio and locate its main harness.
- Refer to the wiring diagram and connect the wires from aftermarket radio main harness to the GM3 T-harness and match the wire functions.

STEP 2

- If the vehicle is equipped with an OEM backup camera, connect the backup camera harness to the Human Machine Interface module harness, located behind the glove box. Note: The guide lines of the backup camera will not be retained.

STEP 3

- Connect the factory harness to the GM3 T-harness.

STEP 4

Plug the climate control portion of the GM3 T-harness into the climate controls.

STEP 5

- Plug the male BLACK 3 pin connector of your GM3 T-harness into the OBDII/SW control harness.

- Plug the OBDII connector into the OBDII of the vehicle.

STEP 6

- Remove steering column shroud.
- Plug the steering wheel control T-harness into the harness at the steering wheel (steering wheel connector located at bottom of steering column).

STEP 7

- Plug the aftermarket radio harnesses into the aftermarket radio.
- Connect the backup camera RCA cable harness into the aftermarket radio.
- Plug the Data cable to the data port of the aftermarket radio.
- Insert the Audio cable into the iDatalink 3.5 mm audio jack of the aftermarket radio.

STEP 8

- Connect all the harnesses to the Maestro RR module then proceed test your installation.

TROUBLESHOOTING TIPS:

- To reset the module back its factory settings, turn the key to the OFF position then disconnect all connectors from the module. Press and hold the module's programming button and connect all the connectors back to the module. Wait, the module's LED will flash RED rapidly (this may take up to 10 seconds). Release the programming button. Wait, the LED will turn solid GREEN for 2 seconds.
- For technical assistance call 1-866-427-2999 or e-mail "support@idatalink.com". Visit us at "maestro.idatalink.com/support" and "www.12voltdata.com/forum/"

WIRING DIAGRAM *without an Amplifier*

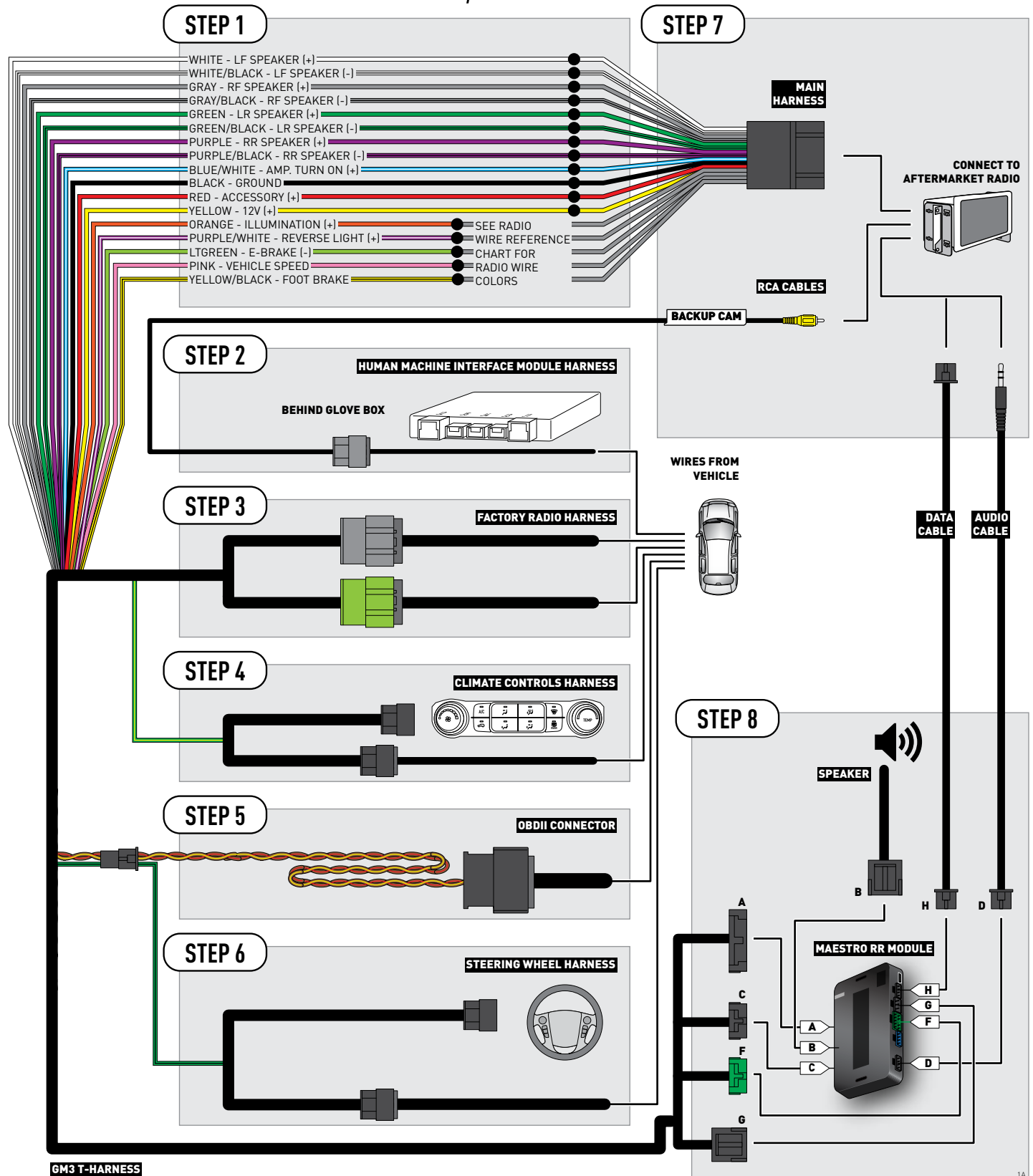

WIRING DIAGRAM *with an Amplifier*

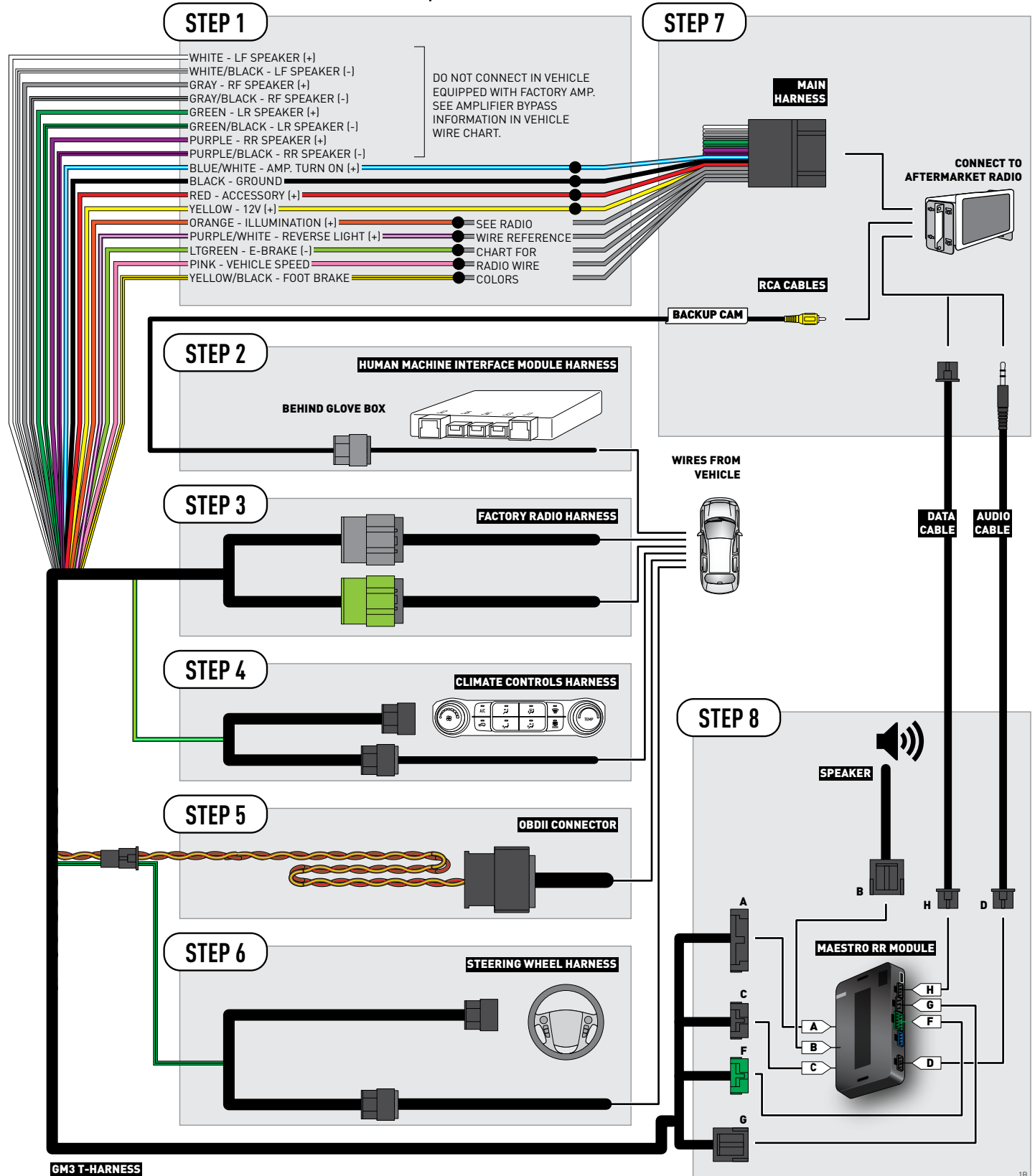

RADIO WIRE REFERENCE CHART

Wire Description	Polarity	Wire Color on Maestro T-Harness	Wire Color on Alpine cable	Wire Color on Kenwood cable	Wire Color on Pioneer cable
Illumination	(+)	Orange	N/A	Orange/White	Orange/White
Reverse Light	(+)	Purple/White	Orange/White	Purple/White	Purple/White
E-Brake	(-)	Lt Green	Yellow/Blue	Lt Green	Lt Green
Foot Brake	(+)	Yellow/Black	Yellow/Black	N/A	N/A
VSS (vehicle speed sensor)	(DATA)	Pink	Green/White	N/A	Pink

VEHICLE WIRE REFERENCE CHART

Wire Description	Connector Name	Connector Color	Connector Type	Position	Wire Color	Polarity	Wire Location
Subwoofer	~	~	8 pin	01	DkBlue/Gray	(+)	Amplifier, left side of cargo area, behind wheel well
Subwoofer	~	~	8 pin	05	Gray/Black	(-)	Amplifier, left side of cargo area, behind wheel well
RF Speaker	~	~	8 pin	02	Yellow	(+)	Amplifier, left side of cargo area, behind wheel well
RF Speaker	~	~	8 pin	06	Yellow/Black	(-)	Amplifier, left side of cargo area, behind wheel well
LF Speaker	~	~	8 pin	03	DkBlue	(+)	Amplifier, left side of cargo area, behind wheel well
LF Speaker	~	~	8 pin	07	Brown/DkBlue	(-)	Amplifier, left side of cargo area, behind wheel well
RF Tweeter (if equipped)	~	~	16 pin	04	Brown/LtGreen	(+)	Amplifier, left side of cargo area, behind wheel well
RF Tweeter (if equipped)	~	~	16 pin	12	Purple/Brown	(-)	Amplifier, left side of cargo area, behind wheel well
LF Tweeter (if equipped)	~	~	16 pin	05	Yellow/DkBlue	(+)	Amplifier, left side of cargo area, behind wheel well
LF Tweeter (if equipped)	~	~	16 pin	13	Yellow/Gray	(-)	Amplifier, left side of cargo area, behind wheel well
RR Speaker	~	~	16 pin	06	White	(+)	Amplifier, left side of cargo area, behind wheel well
RR Speaker	~	~	16 pin	14	DkBlue/Black	(-)	Amplifier, left side of cargo area, behind wheel well
LR Speaker	~	~	16 pin	07	LtGreen	(+)	Amplifier, left side of cargo area, behind wheel well
LR Speaker	~	~	16 pin	15	LtGreen/Black	(-)	Amplifier, left side of cargo area, behind wheel well

AMPLIFIER CONNECTORS (WIRE SIDE)

